

REVISIONS					
REV	ECO	DESCRIPTION	DATE	BY	APPR
A1	--	FIRST RELEASED	Sep-17-2018	White	Tommy
A2	--	UPDATED DRAWING	Jan-09-2019	White	Tommy

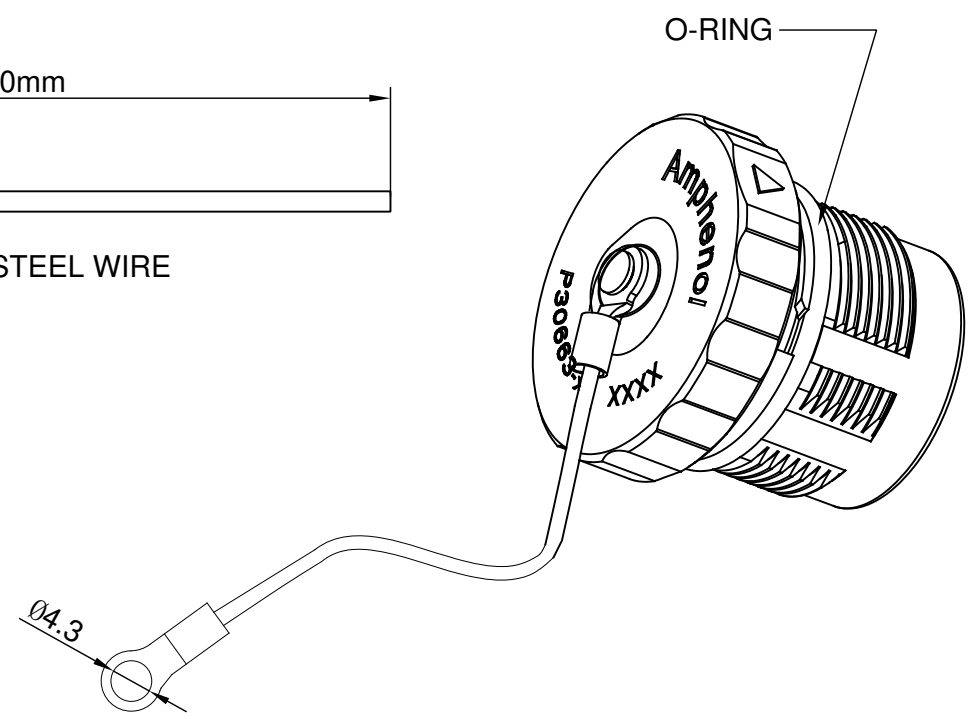
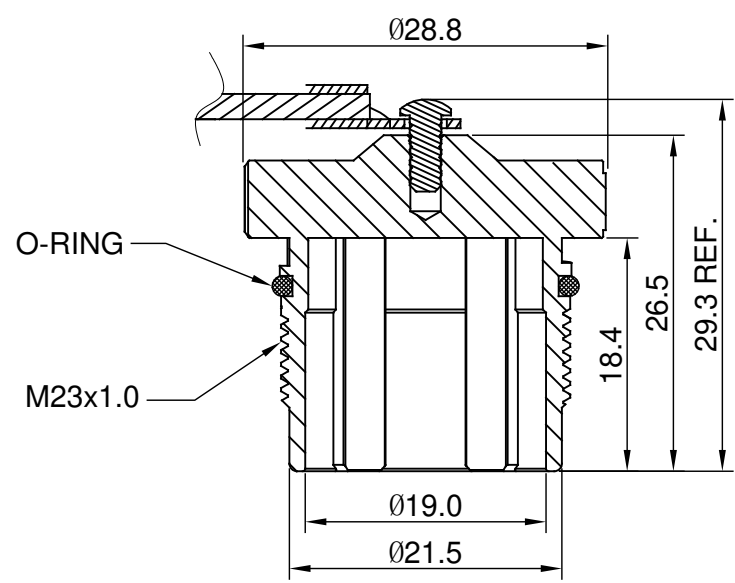
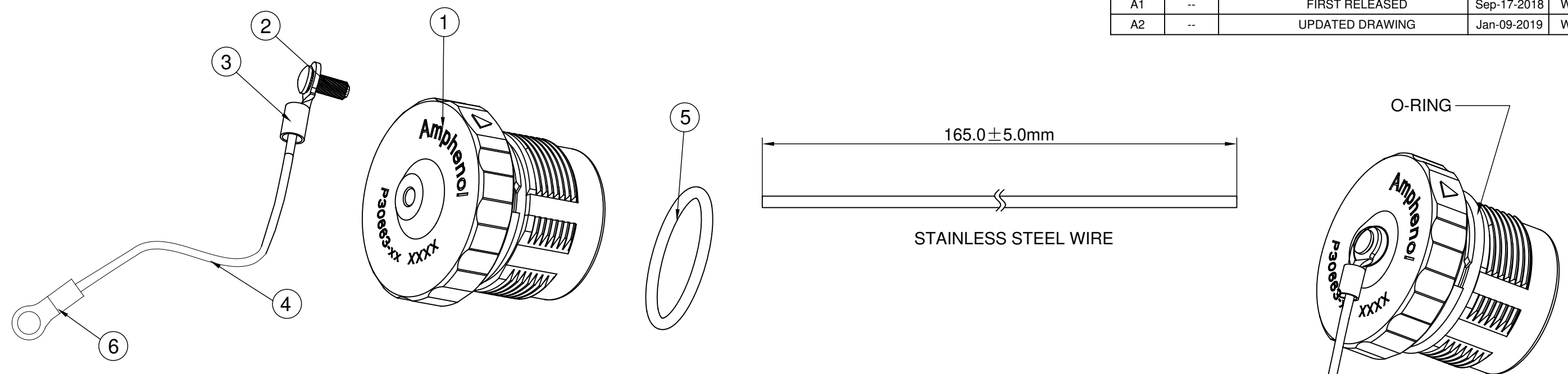

ITEM	P/N	NUT P/N	DESCRIPTION
1	P30663-06	CP-M0829-06	FOR M23B,THREAD,PLUG,6POS
2	P30663-08	CP-M0829-08	FOR M23B,THREAD,PLUG,8POS
3	P30663-09	CP-M0829-09	FOR M23B,THREAD,PLUG,9POS

1	RRNBL14	RING TERMIANL M4	6
1	RB000024	O-RING, 17.5MM(ID)*1.6MM, BLACK VITON	5
165mm	RM0061	STAINLESS STEEL WIRE	4
1	RSC000021	RING TERMIANL M3	3
1	RM0084	RIVET,F2.5*6.35	2
1	SEE TABLE(NUT P/N)	METAL COUPLING NUT	1
QUANTITY	PART NUMBER	DESCRIPTION	ITEM

- NOTES : (UNLESS OTHERWISE SPECIFIED)
- MATERIAL :
NUT : ZINC DIE CAST, NICKEL PLATED.
RIVET : STAINLESS STEEL.
WIRE : STAINLESS STEEL.
 - SPECIFICATIONS :
2.1 MATING CYCLES DURABILITY : 500 CYCLES MIN.
2.2 IP--CLASS : IP67 (IN MATED CONDITION)
2.3 RoHS COMPLIANT.
 - ALL DIMENSIONS ARE FOR REFERENCE USE ONLY.

UNLESS OTHERWISE SPECIFIED		SIGNATURES	DATE
1) All dimensions are in metric(mm). 2) Tolerances are as follows: 1 PL DEC ±0.30 2 PL DEC ±0.15 3 PL DEC ±0.08		White	Jan-09-2019
Fractions ±1/64 Angles ±1°		Tod	Jan-09-2019
3) Note reference =		Tommy	Jan-09-2019
MATERIAL SPECIFICATIONS:	CUSTOMER:	<p style="text-align: center;">Amphenol</p> <p>Sine Systems - www.amphenol-sine.com 44724 Morley Drive Clinton Township, MI 48036</p> <p style="text-align: center;">DUST CAP FOR M23B THREAD PLUG</p>	
PROCESS SPECIFICATIONS:	THIS DRAWING IS SUPPLIED FOR INFORMATION ONLY. DESIGN FEATURES, SPECIFICATIONS AND PERFORMANCE DATA SHOWN HEREON ARE THE PROPERTY OF THE AMPHENOL CORPORATION. NO RIGHTS OF REPRODUCTION ARE IMPLIED. ALL DIMENSIONS ARE SUBJECT TO NORMAL MANUFACTURING VARIATIONS.		
NEXT ASSY:			
SIZE	TYPE	DWG NO.	REVISION
B	C-	P30663-XX	A2
SCALE:	NONE	SHEET	1 OF 1

TITLE: DUST CAP FOR M23B THREAD PLUG
DWG NO: P30663-XX
REV: A2
SH: 1
OF: 1