

REVISIONS			
REV.	DESCRIPTION	DATE	APPROVED
A	ADDED MOUNTING PAD, REDRAWN	01/16/15	N.D.

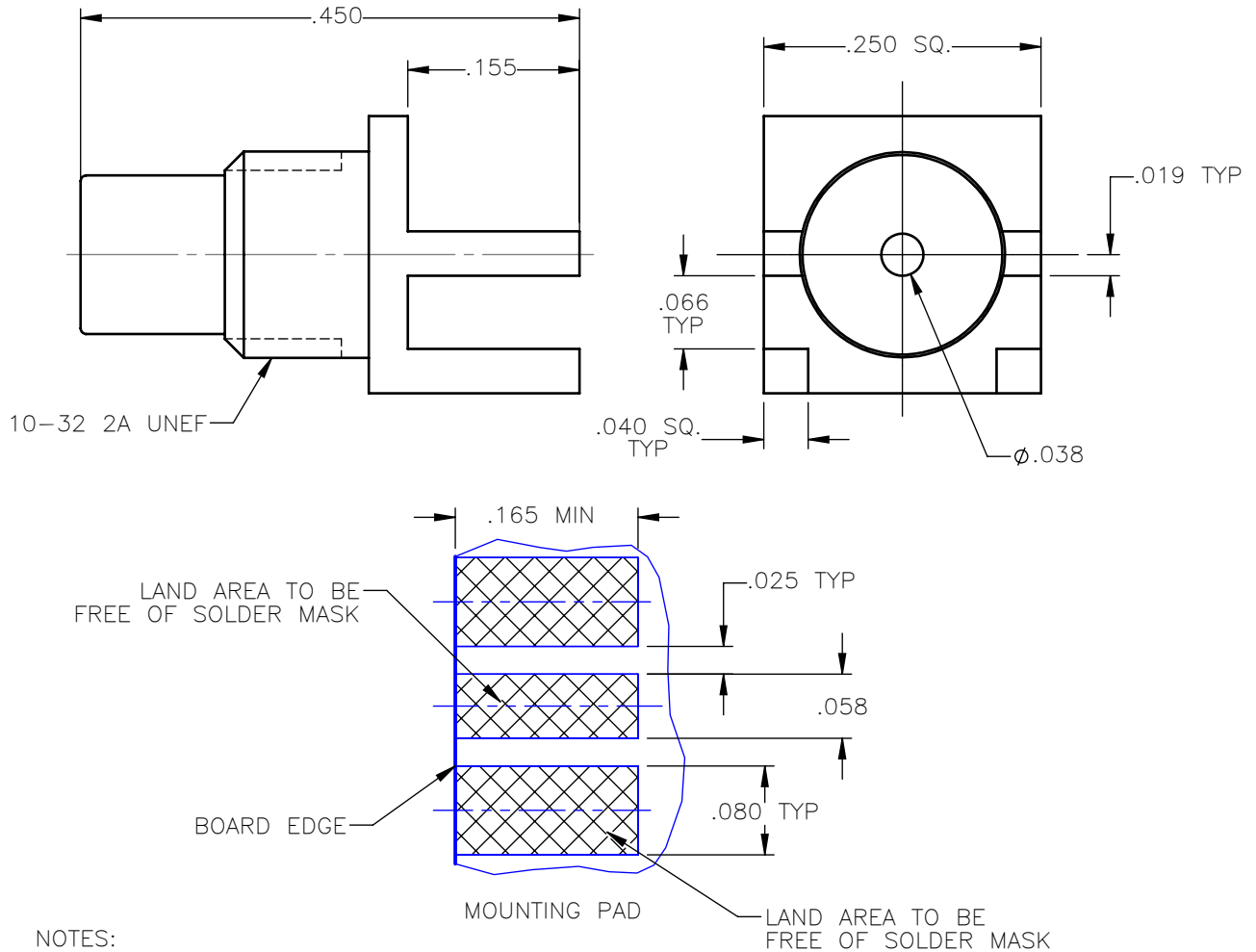



NOTES:

MATERIALS:

- BODY & CONTACT = BRASS PER ASTM B16, ALLOY C36000, TEMPER H02.
- INSULATOR = VIRGIN WHITE TEFLON PER ASTM D1710, GRADE 1, TYPE I, CLASS "B".

FINISHES:

- BODY = GOLD PLATE PER ASTM B488-01, TYPE II, 30 μ in MIN, GRADE C OVER 100 TO 200 μ in COPPER STRIKE PER MIL-C-14550.
- CONTACT = GOLD PLATE PER ASTM B488-01, TYPE II, 50 μ in MIN, GRADE C, OVER 100 TO 200 μ in STRESS FREE SULFAMATE NICKEL PER QQ-N-290.

UNLESS OTHERWISE SPECIFIED DIMENSIONS ARE IN INCHES TOLERANCES ON	DWN: A.D.M.	DATE: 07/23/03	 Property of Radiall This document cannot be reproduced or communicated to a third party without prior written permission of RADIALL.		
	CHKD: D.N.	DATE: 07/23/03			
DECIMAL	ANGLE	APVD: J.M.	DATE: 07/23/03	SMC STRAIGHT MALE JACK EDGE MOUNT RECEPTACLE FOR 0.62 BOARD	
REFERENCE:	MATERIALS AND FINISHES:	SIZE: A	FSCM NO.: 19505		DWG NO.: 1009-1511-005
ORIGINATED: A.D.M. DATE: 07/23/03	SEE NOTES	SCALE: 6:1	THIRD ANGLE PROJECTION		REV: A
				SHEET 1 OF 1	

1009-1511-005