

PART NAME: KNOB      SCALE: 1:1      DATE: 4/22/47      DR. BY DWT

THIS DRAWING IS THE PROPERTY OF DAVIES MOLDING COMPANY, IS SUBMITTED SOLELY AS A DESIGN OR ENGINEERING PROJECT. WE ACCEPT NO RESPONSIBILITY WHATSOEVER FOR THE PRACTICAL APPLICATION OF THE PIECES MADE TO THIS DESIGN.



DESIGNERS & MANUFACTURERS OF KNOBS, HANDLES, CASES & CUSTOM PLASTIC COMPONENTS

P/N	3003SM
M NO.	3003
PIN NO.	3003-11
SHIM NO.	# 1
PIN PLT	3003-11
INSERT	10035

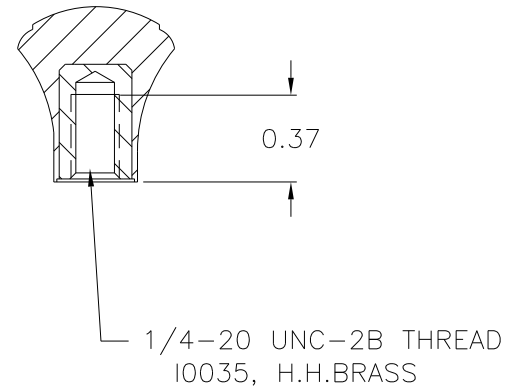
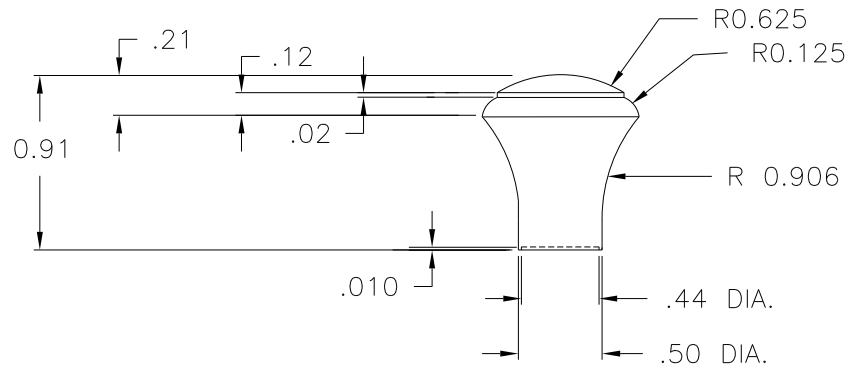
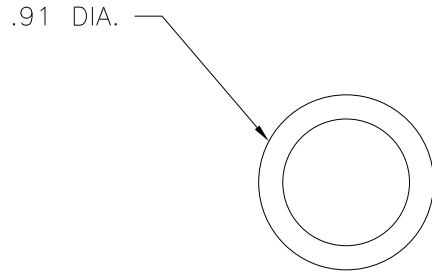

MATERIAL: G.P. PHENOLIC (B11)  
COLOR: BLACK

TOLERANCES: UNLESS OTHERWISE SPECIFIED	DO NOT SCALE DRAWING			
DECIMALS: X.XXX ± .005 X.XX ± .015	MM: X.XX ± 0.15MM X.X ± 0.4MM	-	CAD/REDRAWN	HD 8/27/97
FRACTIONS ± 1/64	ANG. ± 1°	CHANGES		