

INSTRUCTION MANUAL NO.	
IS-0117E	
ISSUED	2001-06-01
REVISED	2005-01-13
REV.	A

STRAIGHT-ACTION (SHORT-HANDLE TYPE) HAND CRIMP TOOL

OPERATING MANUAL



Molex Japan Co., Ltd.

Molex Japan Co., Ltd.		Contents of Update		Instruction Manual No.		IS-0117E	
Title	Straight-Action (Short-Handle Type) Hand Crimp Tool			Tool Number			
Rev.	Issued	Description					
0	2001/06/01	New creation release.					
A	2005/01/13	Changed the form into the bilingual version. ECN-JM50012			Prepared by	Y. Ishiwata	
					Checked by	T. Yoshida	
					Approved by	A. Horino	

<Safety Precautions>

Please read the following before operating the tool.

1. Introduction

Thank you for choosing our **Hand Crimp Tool**.

This document is prepared so that the tool is properly used.

Please take the time to read this manual, making sure you understand the operating procedures described herein before attempting to operate the tool.

2. Dangerous operations

- 1) Don't insert a part of your body or other foreign materials in the hand crimp tool (hereinafter referred to as the "tool") while you're operating the handle of a tool, as injury may result.
- 2) Beware of a handle when it is opened. Releasing a ratchet may cause the handle to open abruptly, resulting in injury.
- 3) Only users who have received adequate training on usage and safety from their manager, and have appropriate knowledge and skills must use the tool. Use by unfamiliar users may cause injury.

<Caution>

- 1) Unauthorized reproduction of this document in part or in whole is prohibited.
- 2) The contents of this document are subject to change without notice.
- 3) Molex Japan Co., Ltd. assumes no responsibility for losses resulting from use or misuse of this document.

<Safety Precautions>

Please read the following before operating the tool.

3. Careful handling

- 1) Always check the tool number, applicable terminal and wire size, etc. before using the tool in the crimping process.
- 2) Check the tool for any damage, and repair prior to use. Defective crimping may result in fire.
- 3) Clean the tool regularly if used frequently.
- 4) Avoid storing the tool in extremes of temperature, or high-humidity environment.
- 5) Keep the tool in a place out of reach of children in order to prevent accidents.

4. Must not be carried out

- 1) Use the tool only for the intended purpose. Don't use it in place of a hammer, pliers, or other tools. Don't remodel the tool. Parts damage may result in accident or injury.
- 2) Don't use the tool for unspecified terminals. Don't crimp unspecified wires. Both may cause parts damage.
- 3) The ratchet mechanism of the tool is designed based on operation by the grip of the hand. Note that improper handling such as inserting it into other devices and opening the handle forcibly may decrease its capabilities and lifespan.

1. Description

This tool is a straight-action (short-handle type) hand crimp tool, which is designed for crimp-connecting wires to crimp terminal of Molex.

Please confirm the tool number, the applicable terminal number, and the size of the applicable wire marked on the hand crimp tool before attempting to operate this tool.

2. Tool Specification

- 1) Tool name: Straight-Action (Short-Handle Type) Hand Crimp Tool
- 2) Outer dimensions and weight: 215 (width) x 90 (depth) x 15 (thickness) mm, Approx. 400gf
- 3) Management method: Crimp height and crimp strength (Details are described to the crimp specification of a corresponding tool)
- 4) Part names of tool

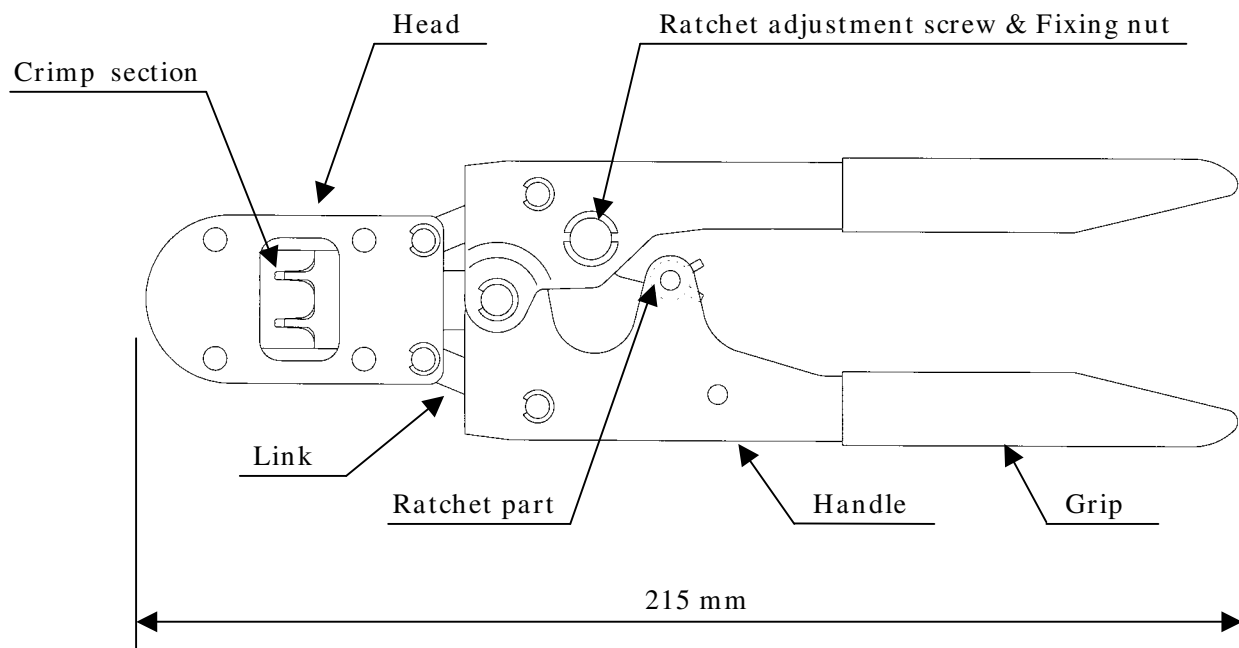

3. Operation Method

- 1) Hold the tool handle, and squeeze it until the ratchet is released. Then, unclench your hand. The handle will be opened by the return spring.
- 2) Insert a “terminal (1)” into the “crimp section (3)” from the “molex logo mark side (2).” Insert a “terminal (1)” so that the “molex logo mark side (2)” faces the “contact”, and the “terminal number engraving side (4)” faces the “barrel (5).”
- 3) Close the handle lightly until the “barrel (5)” of a “terminal (1)” is held by the “insulation punch (6)” and “anvil (7).” At this time, the tip of a “locator (8)” is placed between the “conductor barrel (9)” and the “insulation barrel (10)” so that the “terminal (1)” does not come off.

* Don't tighten the handle excessively, as doing so may cause deformation of the crimp part of a terminal and prevent insertion of a wire.

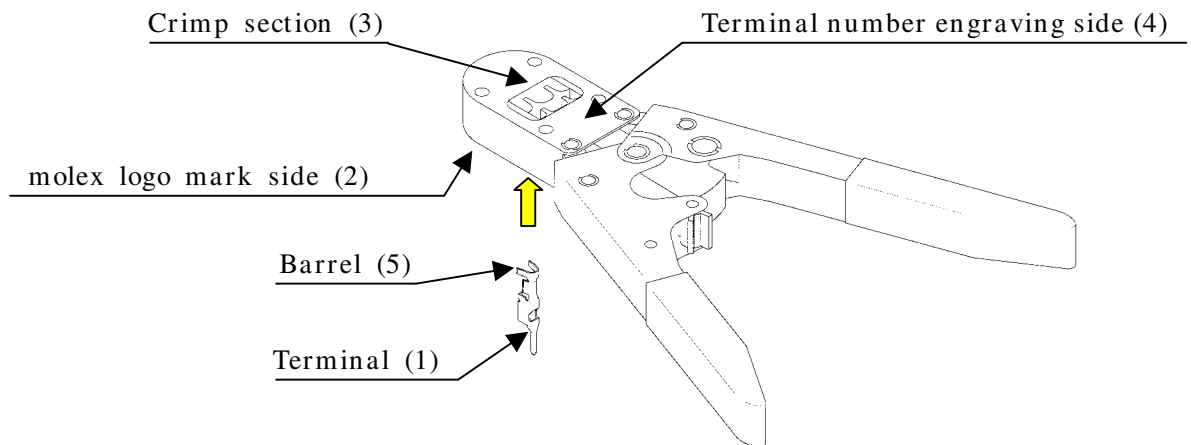

molex logo mark side

Terminal number engraving side

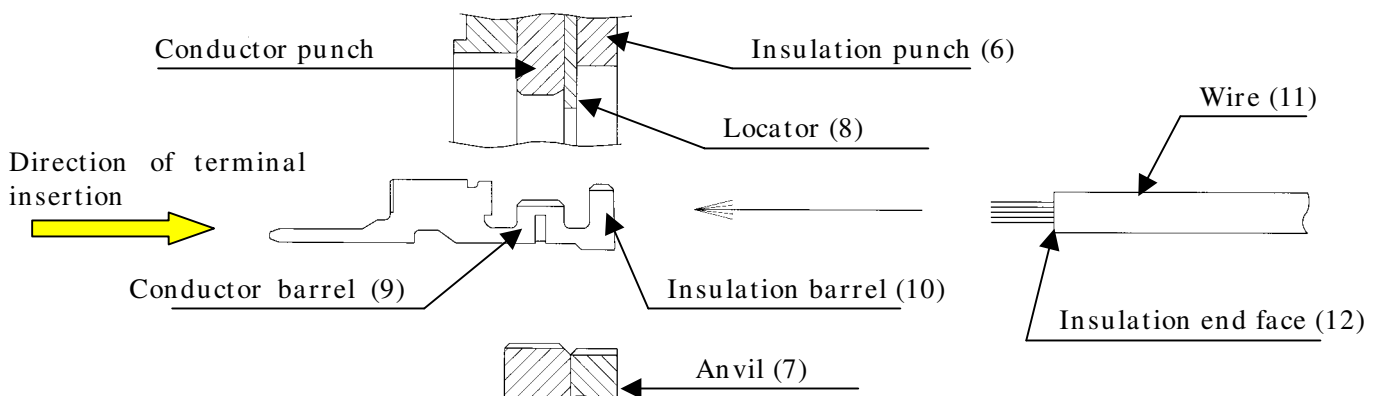

3. Operation Method (continued)

- 4) Insert the stripped “wire (12)” from the “terminal number engraving side (4)” until the “insulation end face (12)” contacts the “locator (8).”
- 5) Squeeze the tool handle firmly until the ratchet is released (clicks), while holding the wire in the same position as in below figure.
- 6) When the ratchet clicks and is released, the handle is automatically opened by the return spring, and the terminal is crimped.
- 7) Holding and pulling the “wire (11)” toward the handle gently removes the crimped terminal.

“Note” Don't tighten the handle excessively after the ratchet is released, as doing so may over-crimp the terminal and cause wire breakage of parts damage.

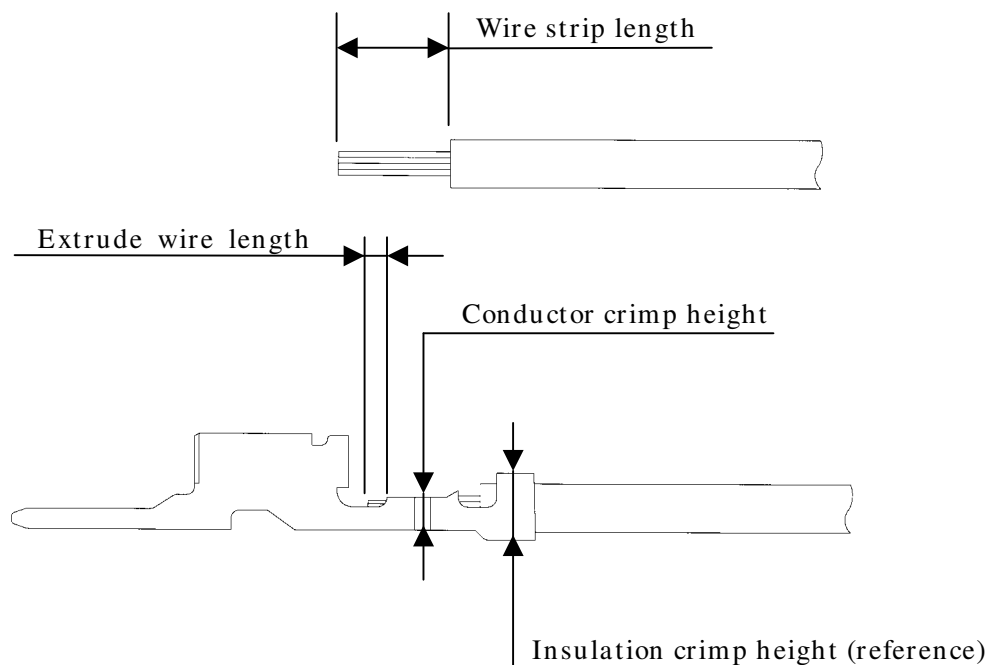

4. Daily Maintenance

4.1. Machinery Inspection and Adjustment

- 1) Check to confirm that the handle moves smoothly (as heeded).
- 2) After using the tool, always apply machine oil or commercial anti-corrosive oil to the crimp section, the link, the ratchet, and other moving parts prior to storage (as needed).
- 3) Loosen the fixing nut for ratchet adjustment screw (eccentric shaft) shown in below figure by attached “exclusive tool”, and rotate the ratchet adjustment screw to change the position at which the ratchet is released.

Always adjust the position when the crimp section cannot be fully closed due to parts wear or the like. Be sure to retighten the fixing nut after completion of adjustment.

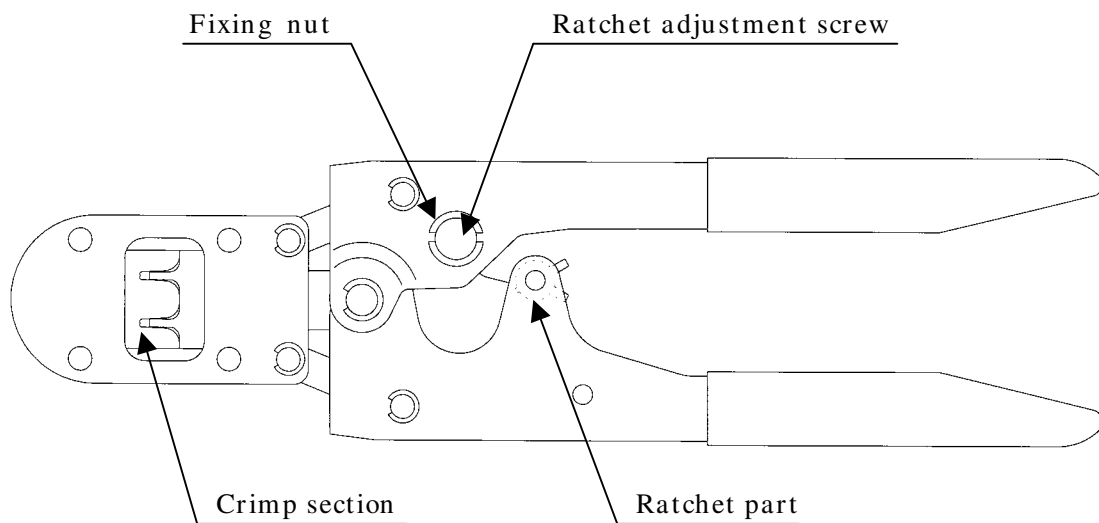

4.2. Crimp Terminal Inspection

1) Crimp height of conductor wire (Crimp height)

- (1) Always check the crimp height of a conductor wire at the beginning and end of daily operation, and also check it regularly during operation.
- (2) Refer to the specification table provided with the tool for crimp height.
- (3) When the crimp height of a conductor wire is not in accordance with the specification, the tool has damaged or reached the end of its lifespan. Please consult our service personnel.
- (4) As this tool crimps wires of various sizes using one set teeth, the insulation crimp height is for reference only.

“Note” We recommend to measure the crimp height of a conductor wire by using the “crimp height micrometer” (J5830-001) of Molex.

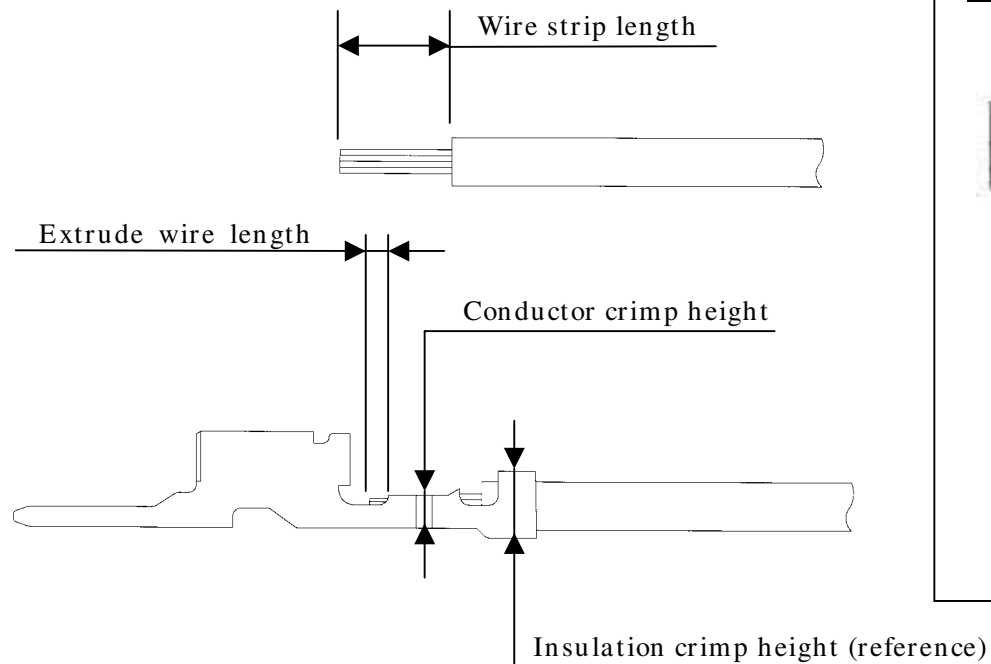

Measurement of crimp height of conductor wire

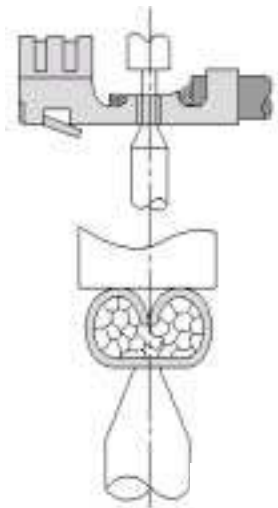

4.2. Crimp Terminal Inspection (continued)

2) Wire pullout strength

- (1) Be sure to check the wire pullout strength regularly.
- (2) Create a test sample like one the below figure and place it in a pullout force tester or a pull gauge. Then apply the standard pullout force of 25 mm/min. to it, and measure the value at the point where the wire is pulled out or fractured.
- (3) Remember that the insulation section should not be crimped.

3) Crack or deform of terminal

Always check to confirm that the crimped terminal is not cracked or deformed.

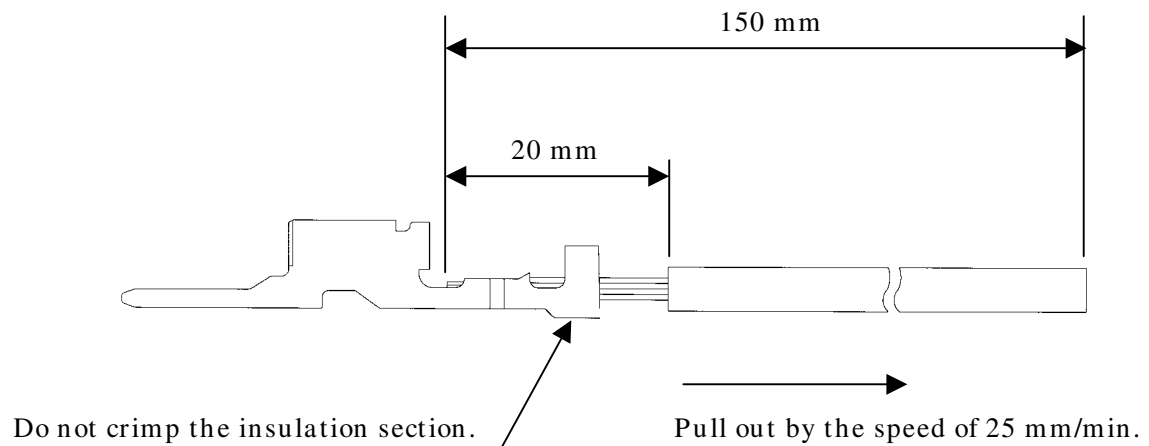

5. Parts List

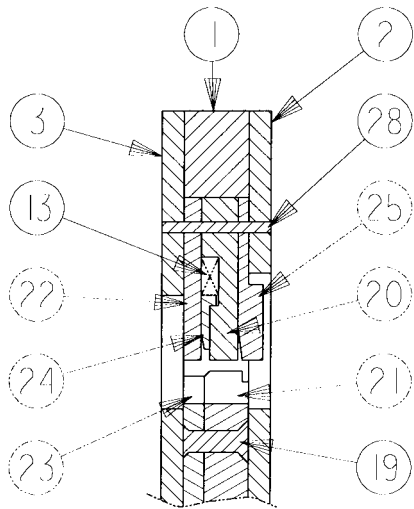

Section A-A

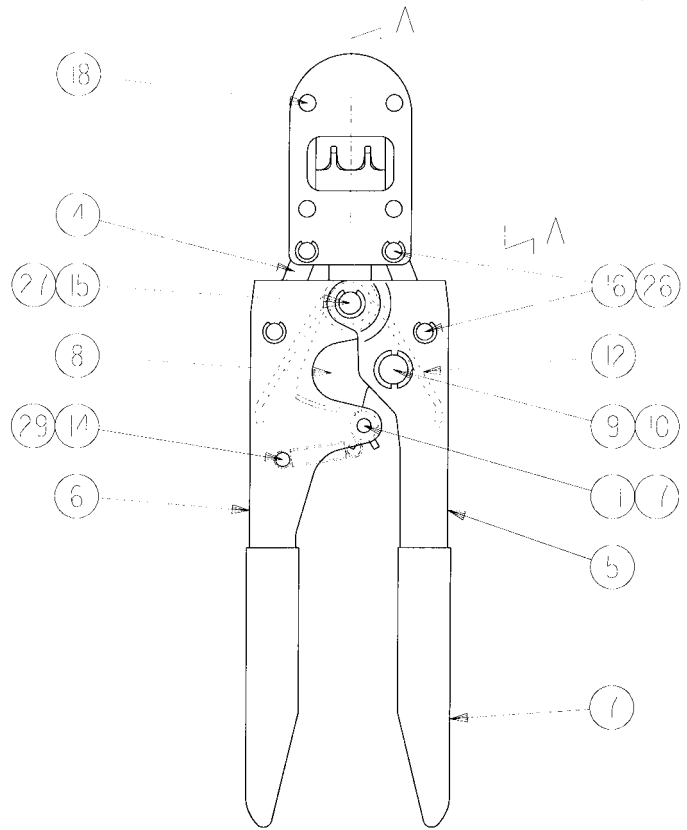

“Note” Parts are not supplied separate

No.	Parts Name	Q'ty	Remarks
1	“U” Head	1	
2	Front Plate	1	
3	Rear Plate	1	
4	Link	4	
5	Handle “A”	1	
6	Handle “B”	1	
7	Grip	2	
8	Ratchet	1	
9	Adjust Screw	1	
10	Nut	1	
11	Pawl	1	
12	Torsion Spring	1	
13	Spring for Locator	2	
14	Pawl Spring	1	
15	Stop Pin (phi6)	1	
16	Stop Pin (phi5)	4	
17	Pin for Pawl	1	
18	Rivet for Head	4	
19	Rivet for Anvil	2	
20	Conductor Punch	(1)	
21	Conductor Anvil	(1)	
22	Insulation Punch	(1)	
23	Insulation Anvil	(1)	
24	Locator	(1)	
25	Support	(1)	
26	C-ring (phi5)	8	
27	C-ring (phi6)	2	
28	Spring Pin (phi2)	1	
29	Spring Pin (phi3)	1	

6. Straight-Action (Short-Handle Type) Hand Crimp Tool Startup Checklist

[Applicable Tool] Straight-Action (Short-Handle Type) Hand Crimp Tool

“Note” Please check the following matter before the commencement of work, and start operation after checking those without a problem.

No.	Checkpoint	Standard	Method/equipment	Check result
1	Crimp height of conductor wire	When you crimp an applicable terminal for the tool, the crimp height of a conductor wire should satisfy the standard.	Check by trial crimping.	
2	Wire pullout strength	The wire pullout strength of an applicable terminal should satisfy the standard.	Check by trial crimping.	
3	Separation of ratchet	When squeeze a tool handle firmly, a ratchet should crick and separate.	Check by trial operation.	
4	Crack of terminal	There are no crack and deformation by the hand tool in a terminal.	Check a crimped terminal visually.	
5	Crimp section	There are no article and dust in a crimp section.	Cleanup	

