

IRU3146 EVALUATION BOARD USER GUIDE

INTRODUCTION

The IRU3146 IC is a Dual synchronous Buck controller, providing a cost-effective, high performance and flexible solution. The IRU3146 can be configured as a 2-independent or as a 2-phase controller. The 2-phase configuration is ideal for high current applications. The IRU3146 features 180° out of phase operation which reduces the required input/output capacitance and results in a fewer number of capacitors needed. Other key features offered by this device include two independent programmable soft starts, programmable switching frequency up to 400KHz per phase, Hiccup current limit and an under voltage lockout function. The current limit is provided by sensing the lower MOSFET's on-resistance for optimum cost and performance.

SPECIFICATION DATA

This reference board is designed to demonstrate all the features of IRU3146 and can be configured to two types of applications:

1) Dual outputs application (Independent Outputs)

2) 2-phase application (Single Output)

This user guide contains the schematic and bill of materials for each of these applications, and the design guidelines are described in data sheet.

The MOSFETs sockets on the evaluation board are dual layout for SOIC-8 and Direct FET footprint.

INPUT/OUTPUT CONNECTIONS

The following is the input/output connections:

Inputs:

JP1: Vin and Gnd
 JU4: VCC and Gnd
 JU5: VCL/VCH1/VCH2

Outputs:

JP2: Vout1 for Dual output
 JP5: Vout2 for Dual output
 JP4: Vout for 2-phase application

Scope Probe connections:

J1 and J3: Inductor point for L2 and L3
 J2 and J4: Outputs for Vout1 and Vout2

The connection points for dual output application are shown in Figure 1. Connect the power supply cables according to this figure, minimizing wire lengths to reduce losses in the wire. Test points J1, J2, J3 and J4 provide easy connection for oscilloscope voltage probe to monitor the inductor points for each PWM section and output voltages.

Dual Outputs

$V_{IN} = 12V$
 $V_{OUT1} = 2.5V$
 $I_{OUT1} = 10A$
 $V_{OUT2} = 1.8V$
 $I_{OUT1} = 10A$
 $\Delta V_{OUT} = 50mV$
 $FS = 300KHz$

2-Phase

$V_{IN} = 12V$
 $V_{OUT1} = 1.8V$
 $I_{OUT1} = 35A$
 $\Delta V_{OUT} = 50mV$
 $FS = 300KHz$

CONNECTION DIAGRAM

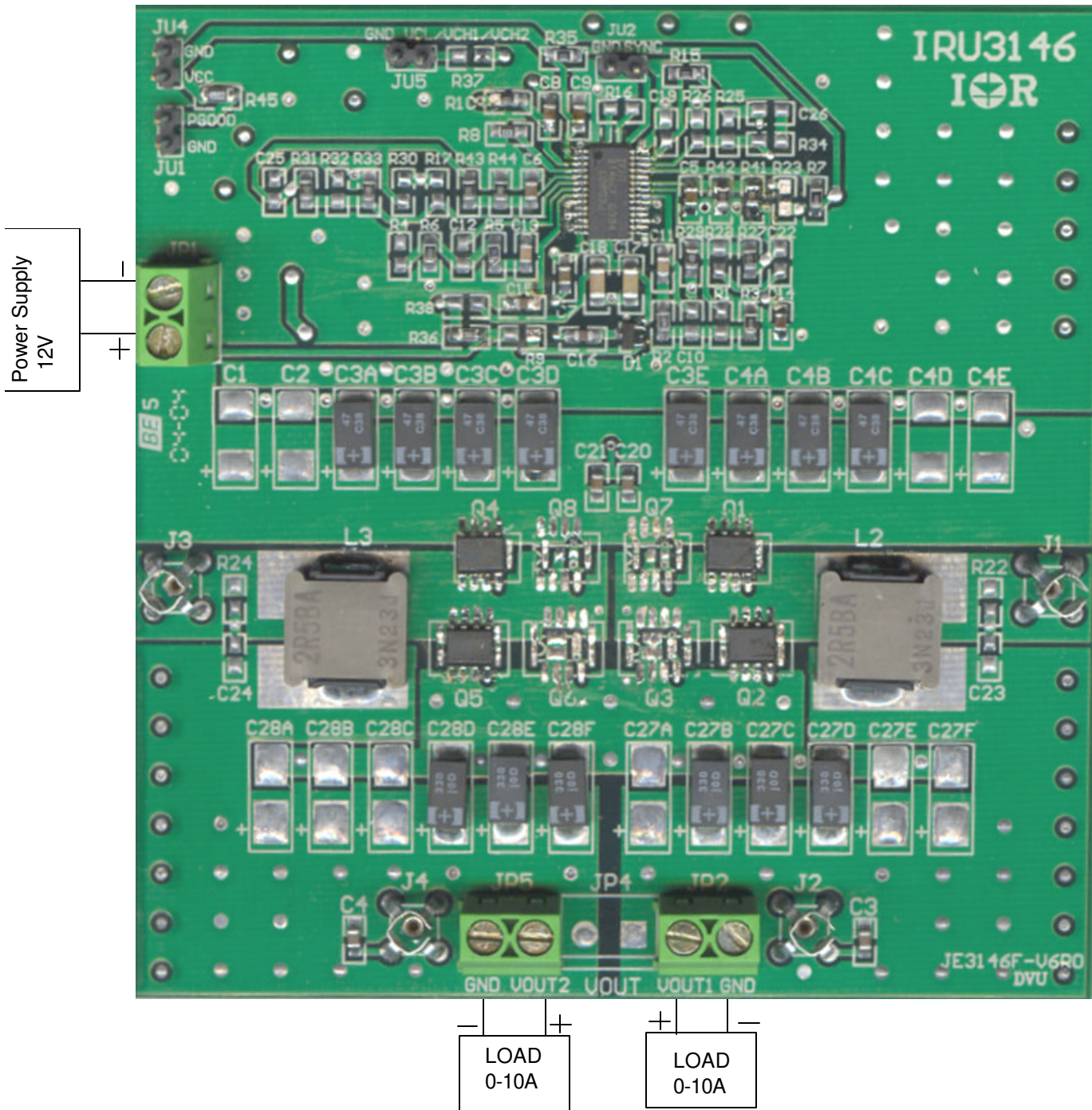

Figure 1 - Connection diagram of evaluation-board for IRU3146 in Dual output configuration

LAYOUT

The PCB is 4-layers FR4 board, the top layer is dedicated for power components, with two parallel control MOSFETs and two parallel Synchronous MOSFETs. These MOSFETs are dual layout for both SOIC-8 and DirectFET footprint. The input capacitors are all located close to MOSFETs. The two output inductors are located closed to MOSFETs and are symmetrical to the output connector for more accurate current sharing result.

The two mid-layers are dedicated for Analog and Power ground, these two grounds are kept separated from each other and they are connected at a single point as shown in Figure3.

All the decoupling capacitors, charge pump capacitor and feedback components are located close to the IC. The feedback resistors are tied to the output voltage at the point of regulation.

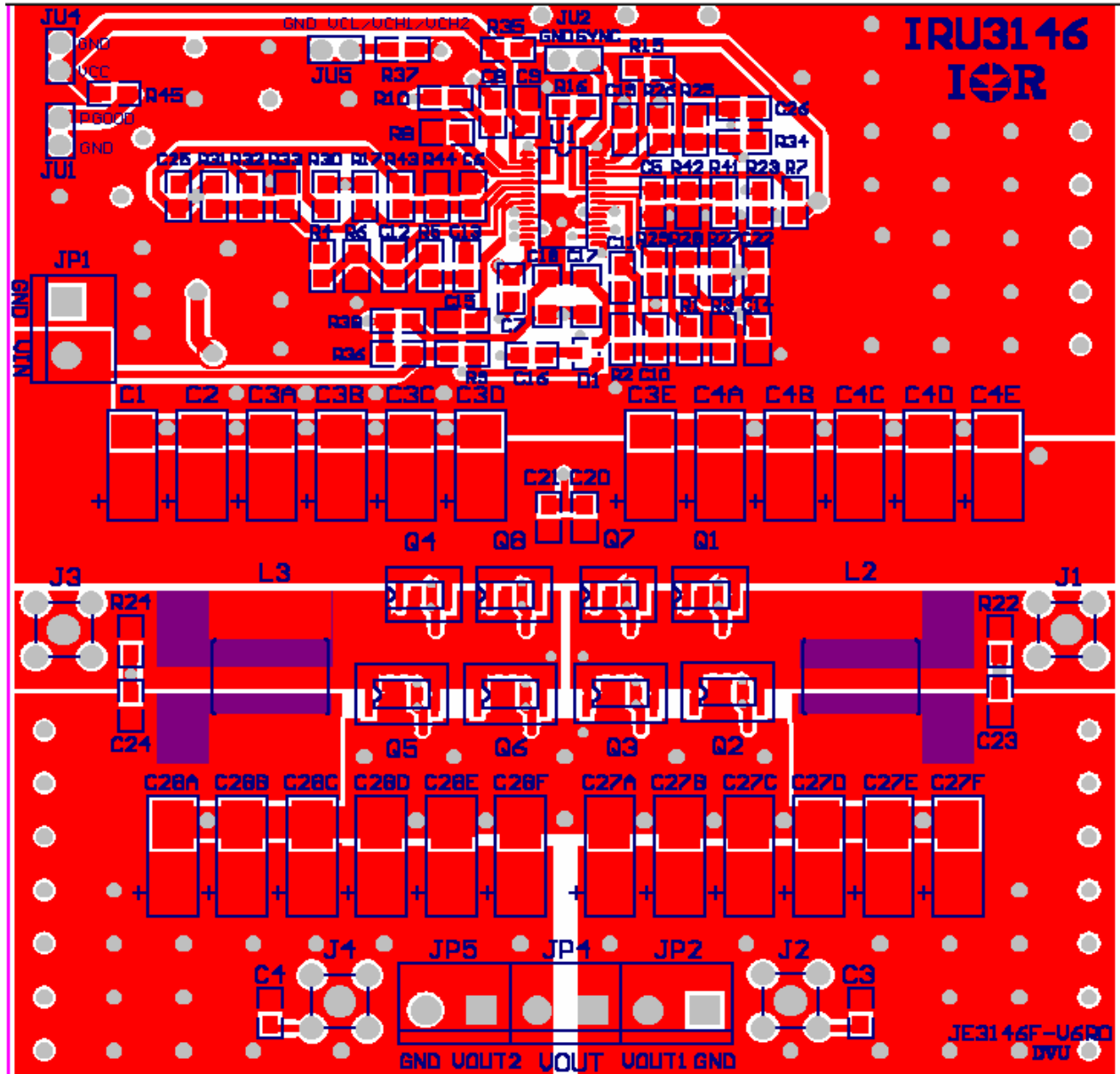

Figure 2 - Top layer of evaluation-board for IRU3146.

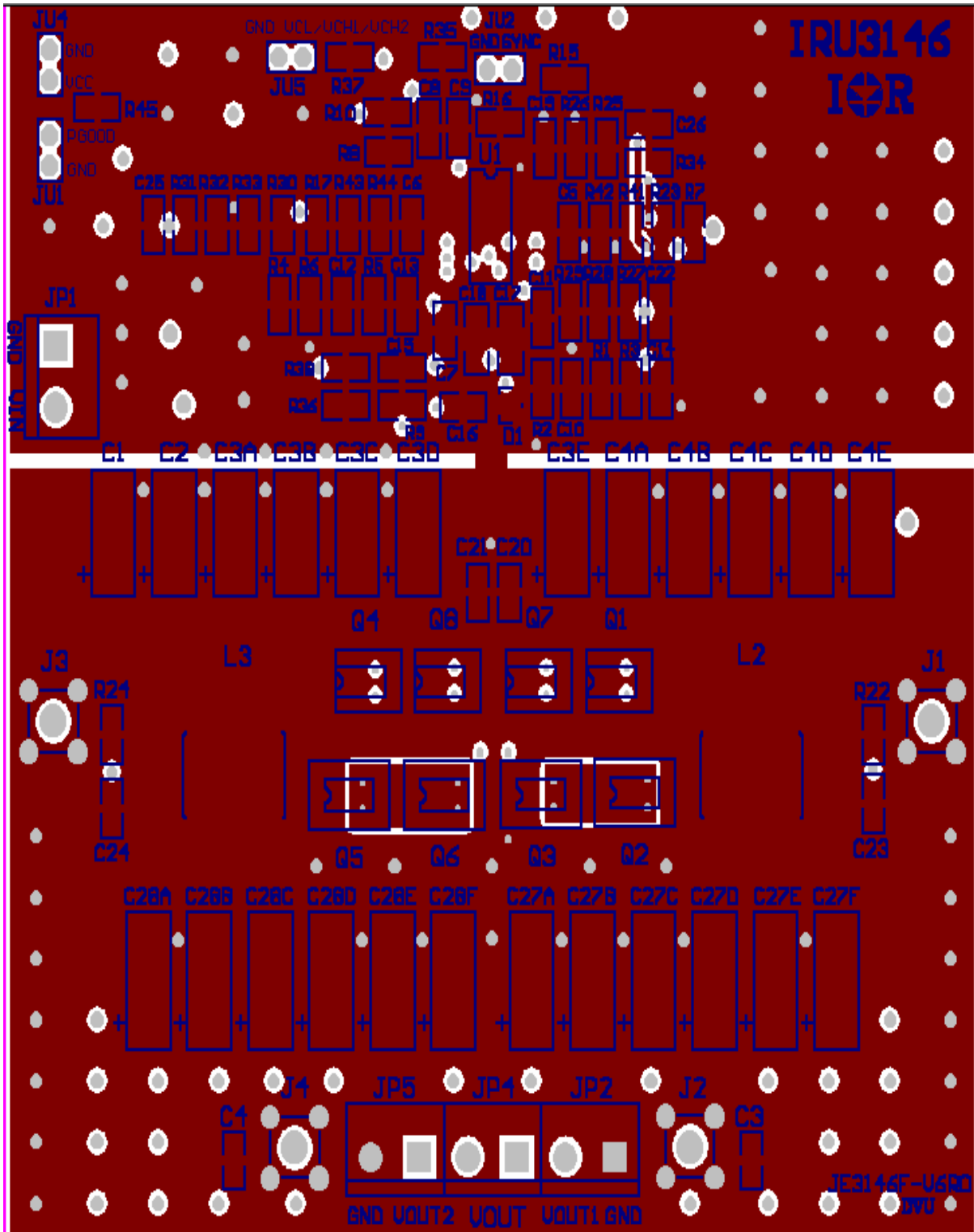
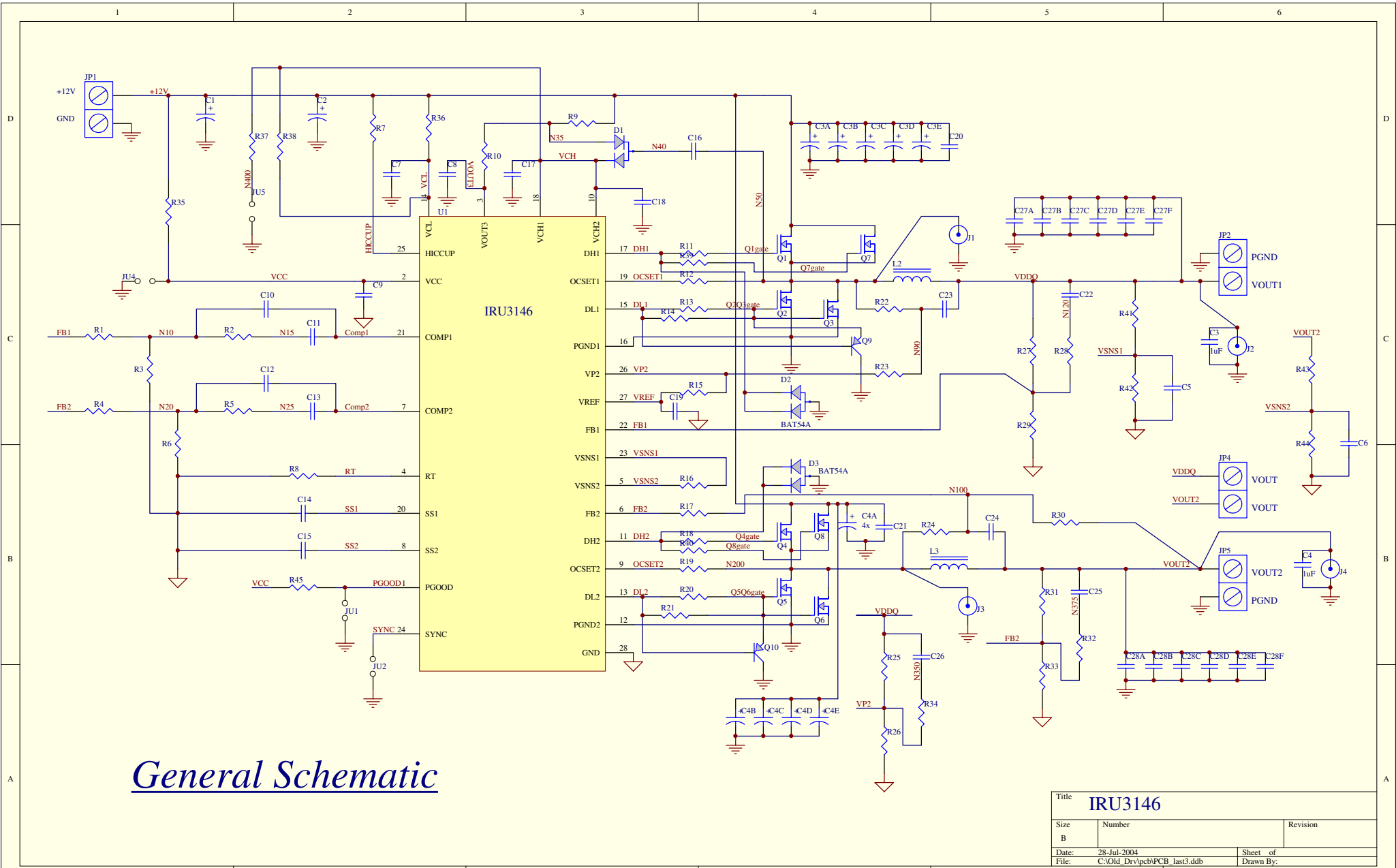
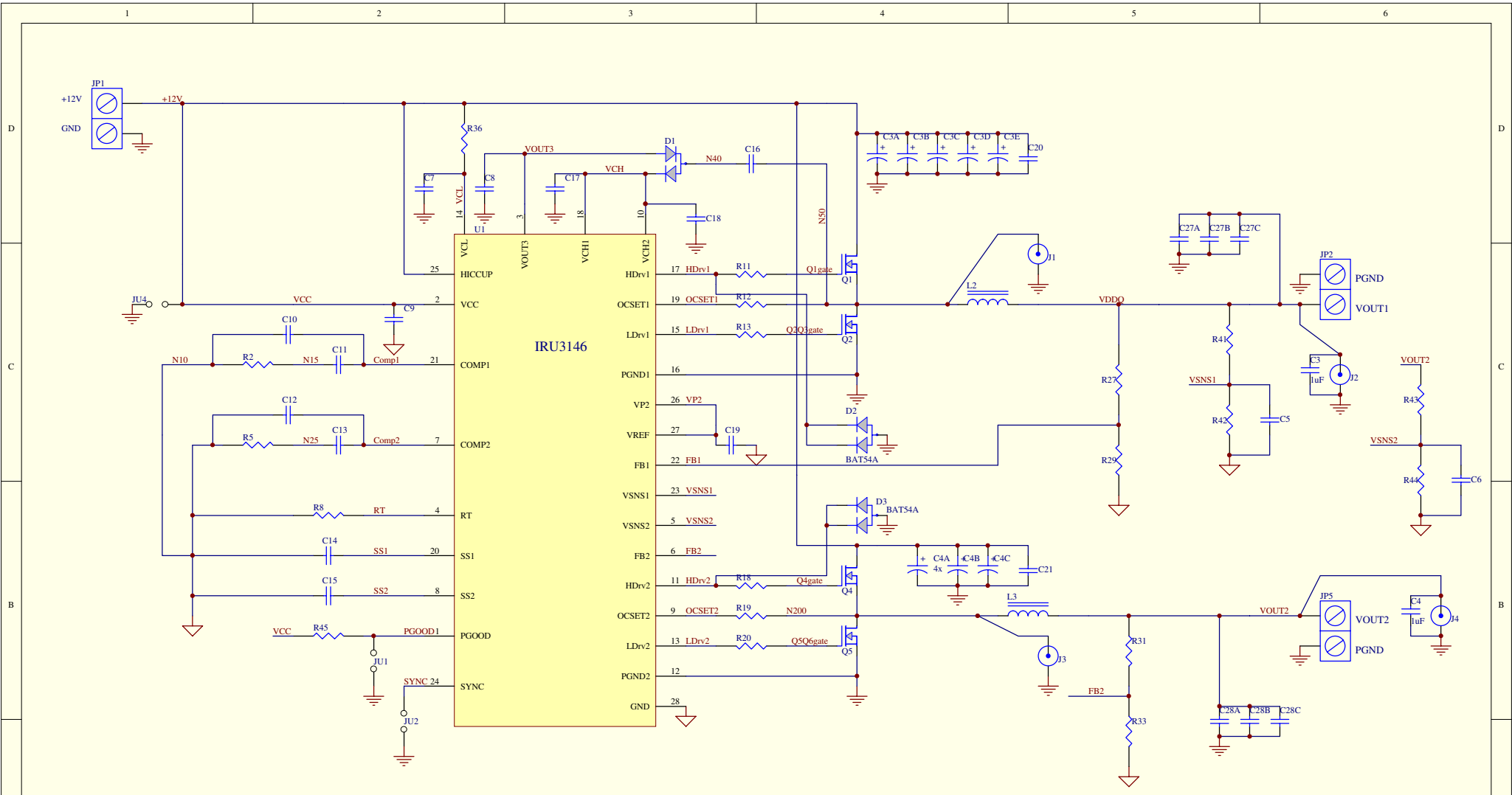

Figure 3 - Mid layer of evaluation-board for IRU3146.



General Schematic

Title			IRU3146		
Size	Number	Revision			
B					
Date:	28-Jul-2004	Sheet of			
File:	C:\Old_Drv\pcb\PCB_last3.ddb	Drawn By:			



Dual Outputs

Title			IRU3146		
Size	Number	Revision			
B					
Date:	28-Jul-2004	Sheet of			
File:	C:\Old_Drv\pcb\PCB_last3.ddb	Drawn By:			

**BILL OF MATERIAL For Dual Output Application, Vin=12V,
 Vout1=2.5V@10A, Vout2=1.8V@10A**

Ref Desig	Description	Value	Qty	Part#	Manuf
Q1,Q4	MOSFET	30V,11mOhm	2	IRF7821	IR
Q2,Q5	MOSFET	30V, 6mOhm	2	IRF8113	IR
U1	Controller	Synchronous PWM	1	IRU3146	IR
D1	Diode	Fast Switching	1	BAT54S	IR
D2,D3	Diode	Fast Switching	2	BAT54A	IR
L2,L3	Inductor	2.45μH,12A,4.9mΩ	2	ETQP6F2R5BFA	Panasonic
C3A-E, C4A-C	Cap,Poscap	47μF, 16V	8	16TPQC47M	Sanyo
C27B-D, C28D-F	Cap,Poscap	330μF,6.3V,40mΩ	6	6TPB330M	Sanyo
C14,C15,C16	Cap,Ceramic	0.1μF, Y5V, 25V	3	ECJ-2VF1E104Z	Panasonic
C17,C18	Cap.Ceramic	1μF, X7R, 25V	2	ECJ-3YB1E105K	Panasonic
C3,C4,C5,C6,C7,C8,C9,C20,C21	Cap.Ceramic	1μF, Y5V, 16V	9	ECJ-2VF1C105Z	Panasonic
C11	Cap.Ceramic	10nF, X7R, 50V	1	ECJ-2VB1H103K	Panasonic
C13	Cap.Ceramic	15nF, X7R, 50V	1	ECJ-2VB1H153K	Panasonic
R2	Resistor	5.65KΩ	1	Any	
R5	Resistor	3.9K	1		
R8	Resistor	33K	1		
R12,R19	Resistor	5.11K, 1%	2		
R27,R41	Resistor	2.15K, 1%	2		
R29,R33,R42,R44	Resistor	1kΩ, 1%	4		
R31,R43	Resistor	1.24K,1%	2		
R45	Resistor	50k,1%	1		
R36	Resistor	100Ω	1		
R3,6,7,10,11,13,15,18,20,35	Resistor	Short, 0Ω	10		
R1,4,9,32,39,14,16,17,40,21,22,23,24,28,	Resistor	Open	14		
R34,37,38,25,26,30	Resistor	Open	6		
C1,2,C3A,C4C-E, C27E-F,C28A-D,	Capacitor	Open	12		
C19,C10,12,23,24,22,25,26	Capacitor	Open	8		
Q3,Q6,Q7,Q8,Q9,Q10	Transistor	Open	6	131-5031-00	Tektronix
J1,J2,J3,J4	Scope Probe		4	ED1973-ND	Digi-Key
JP1,JP2,JP5	Terminal	2-Pos terminal	3	S1012-02-ND	Digi-Key
JU1,JU2,JU4,JU5	Jumper		4	SJ-67A2 Black	3M
Bumpon			4		

TYPICAL OPERATING WAVEFORMS

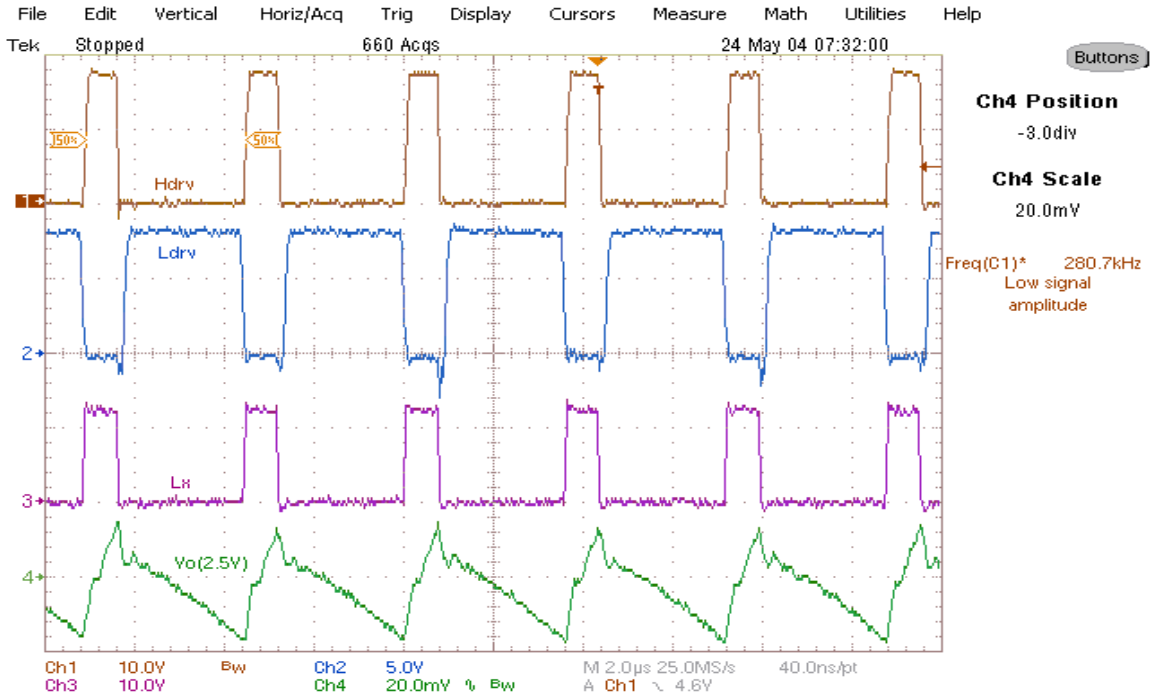

Figure 4- 2.5V Switching Waveforms at no Load

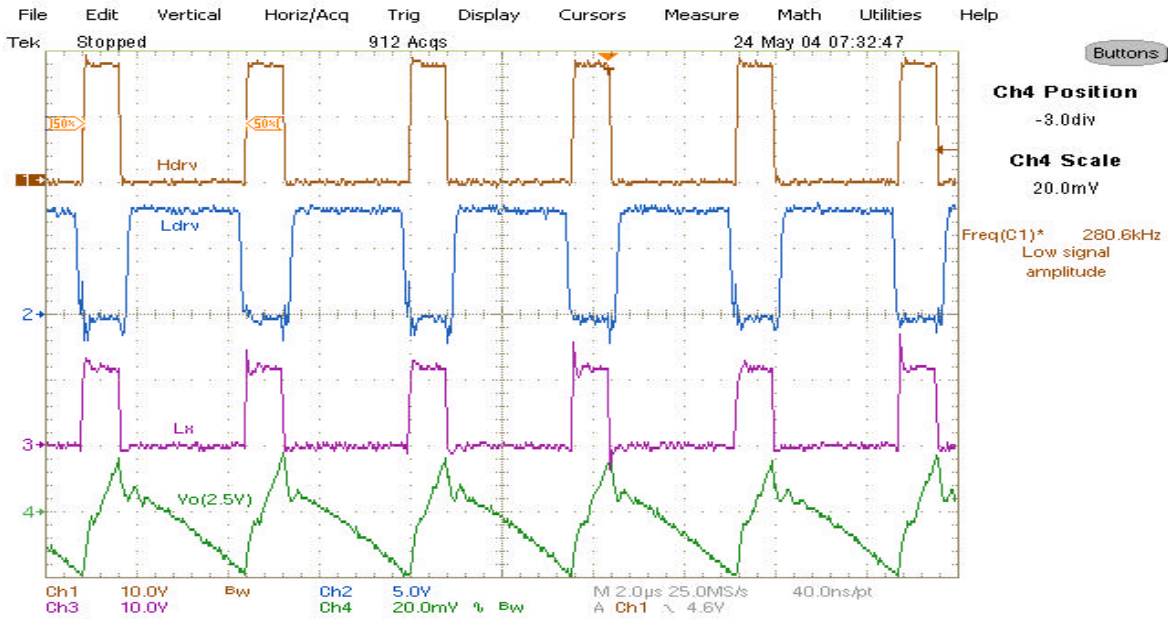

Figure 5- 2.5V Switching Waveforms at 10A Load

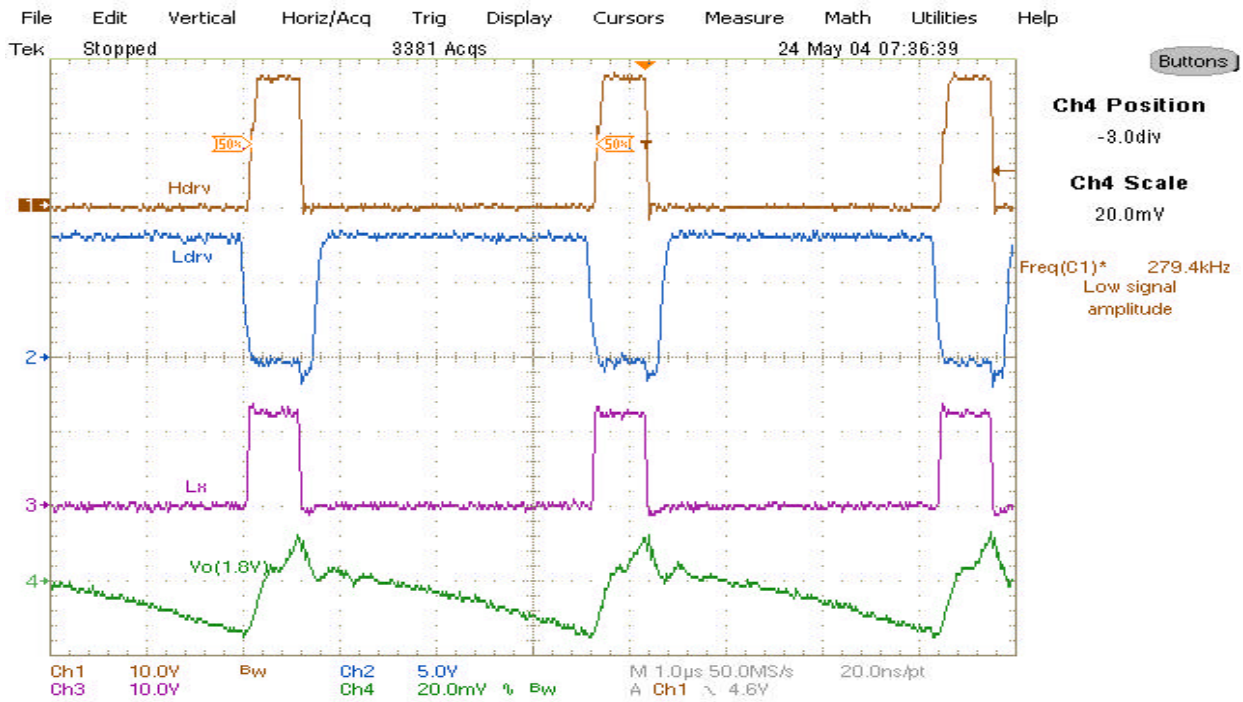

Figure 6- 1.8V Switching Waveforms at no Load

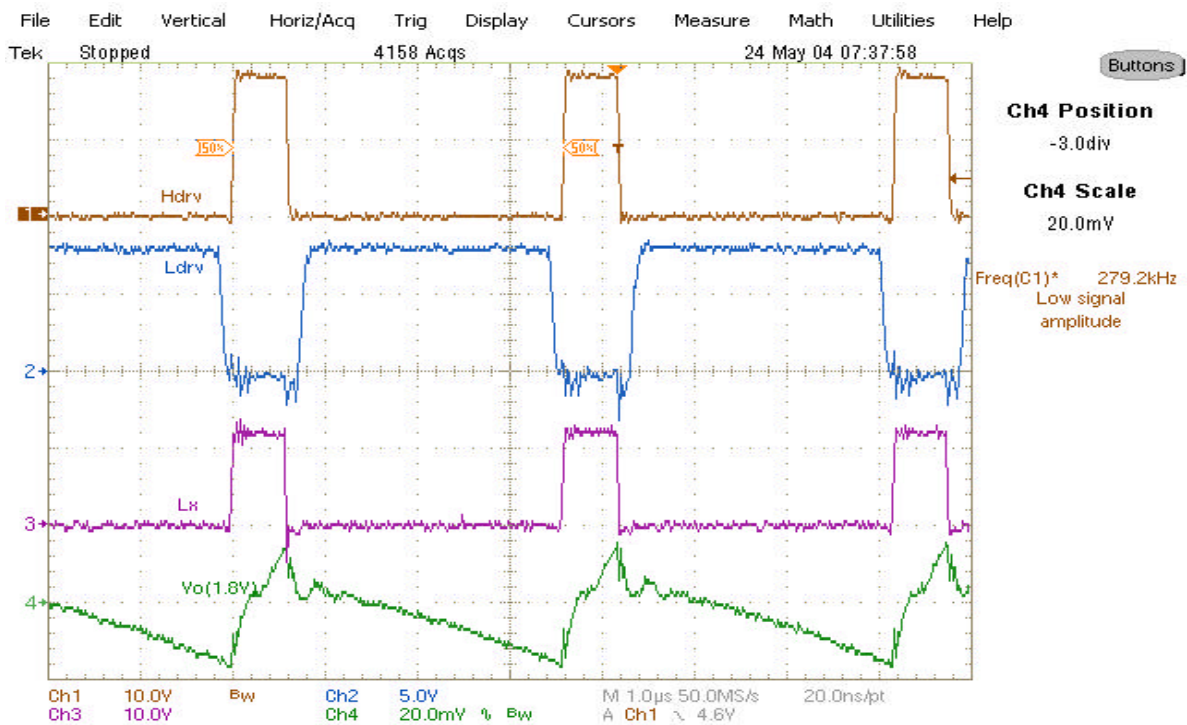

Figure 7- 1.8V Switching Waveforms at 10A Load

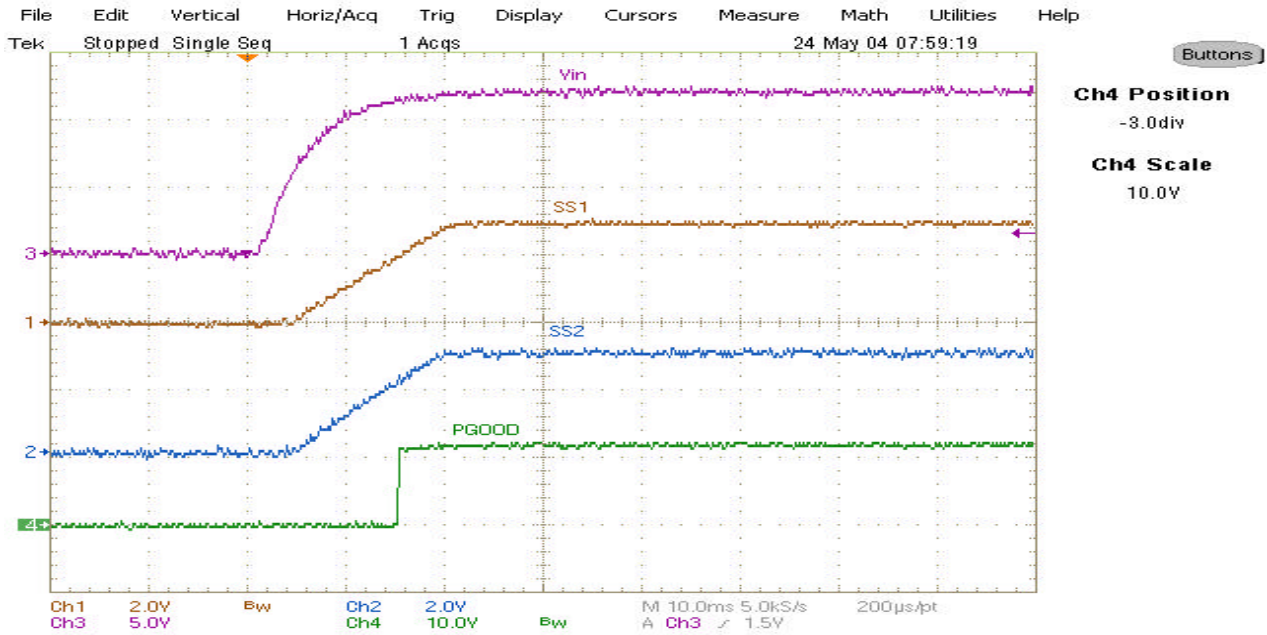

Figure 8- Power Up Waveforms

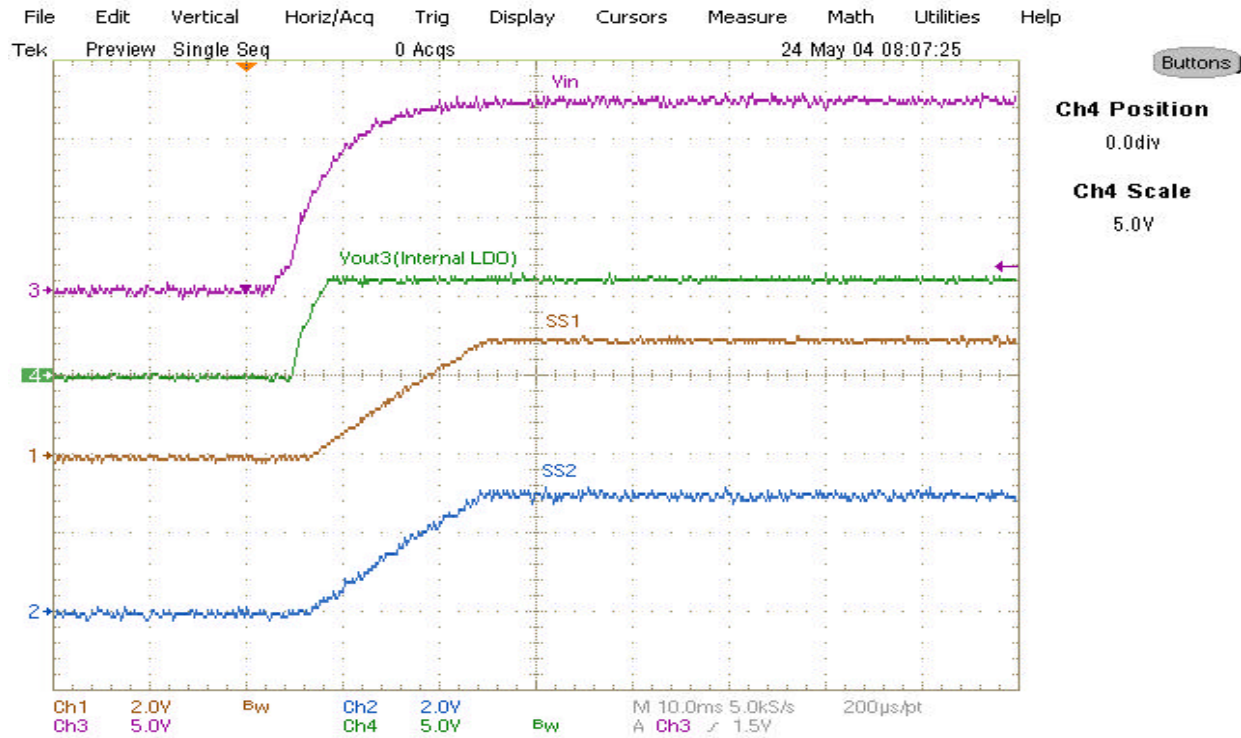

Figure 9- Power Up Waveforms
(Internal Regulator)

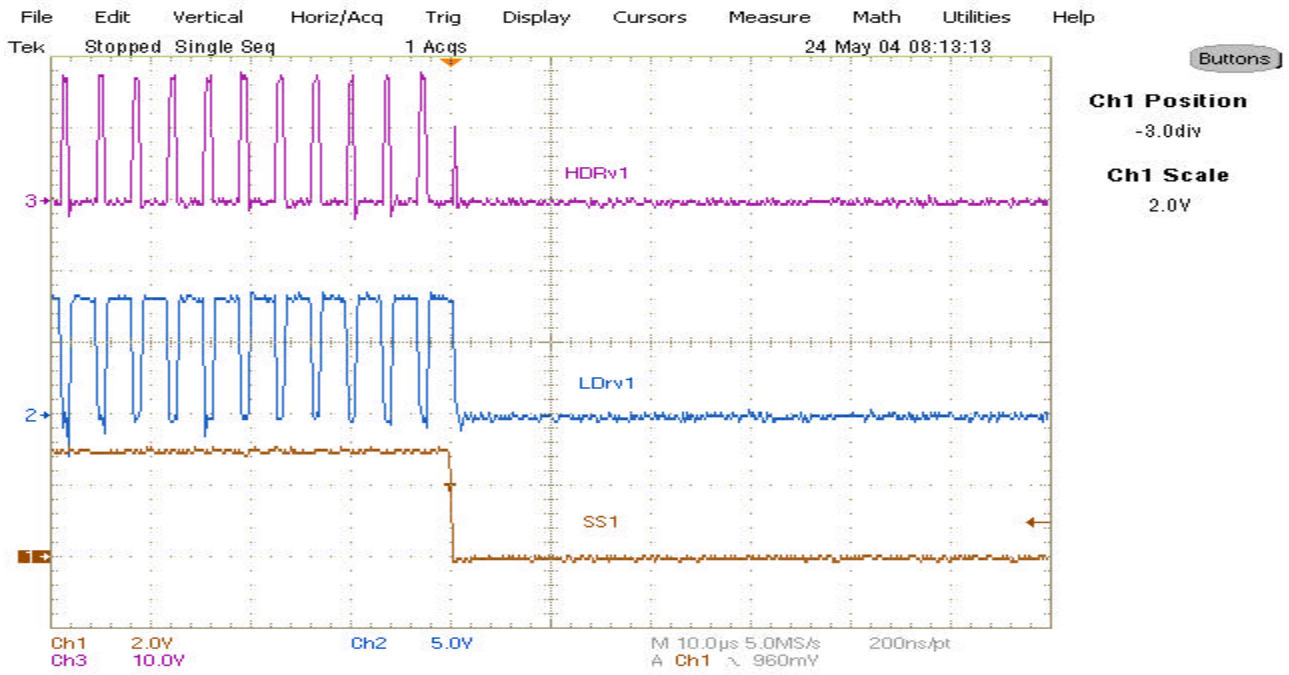

Figure 9- Shut Down, SS1 pulls Low

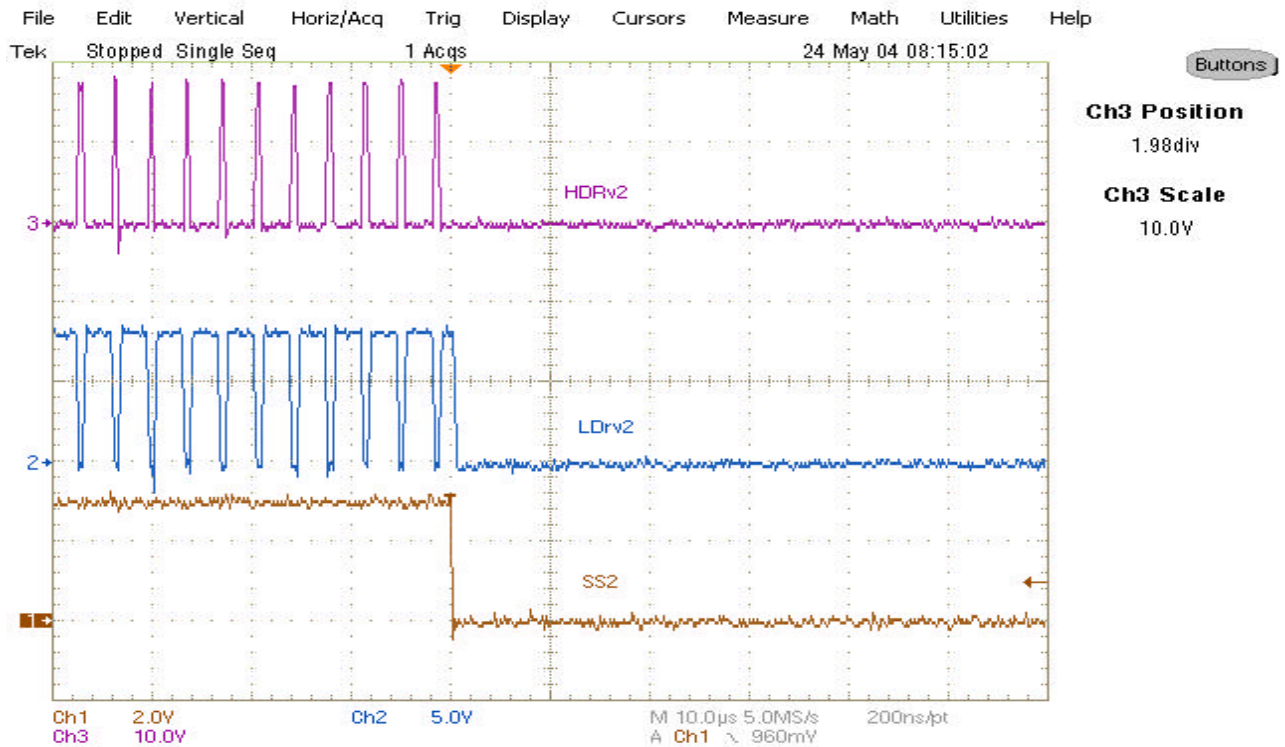

Figure 10- Shut Down, SS2 pulls Low

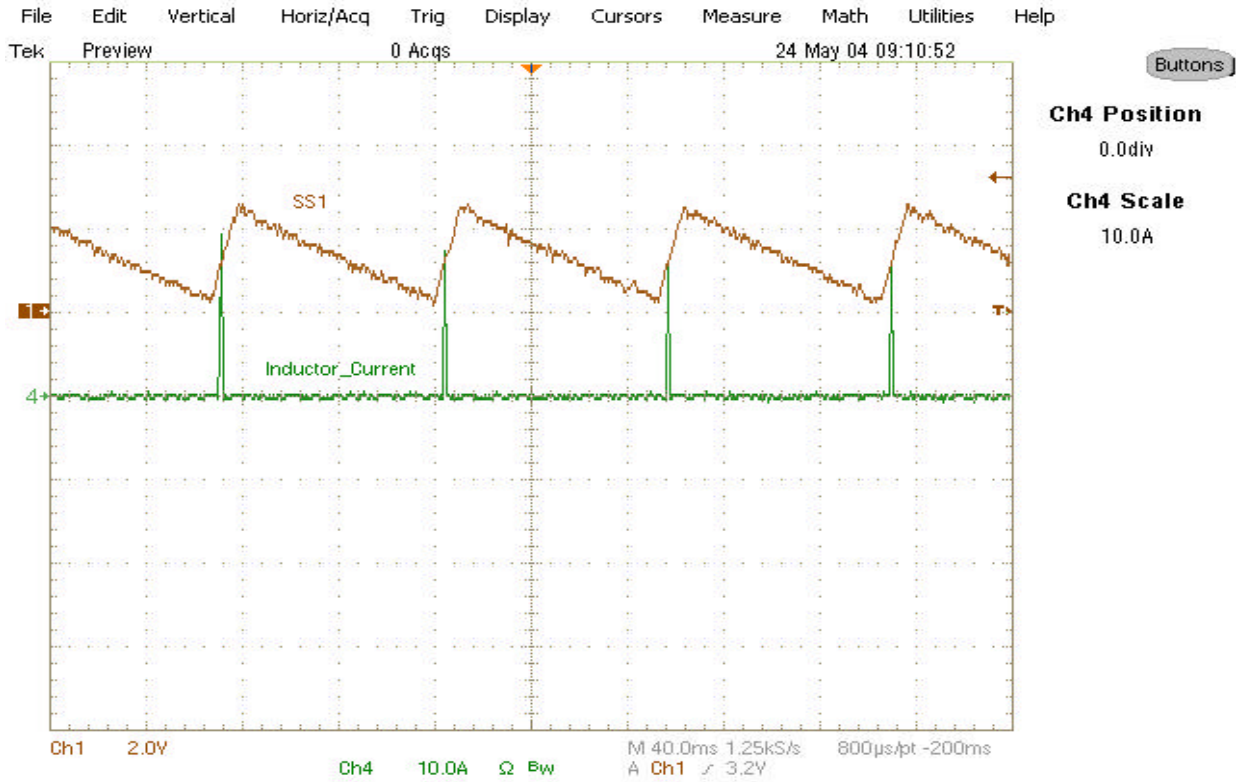

Figure 11- Short Circuit Condition (Hiccup Mode) for 2.5V Output

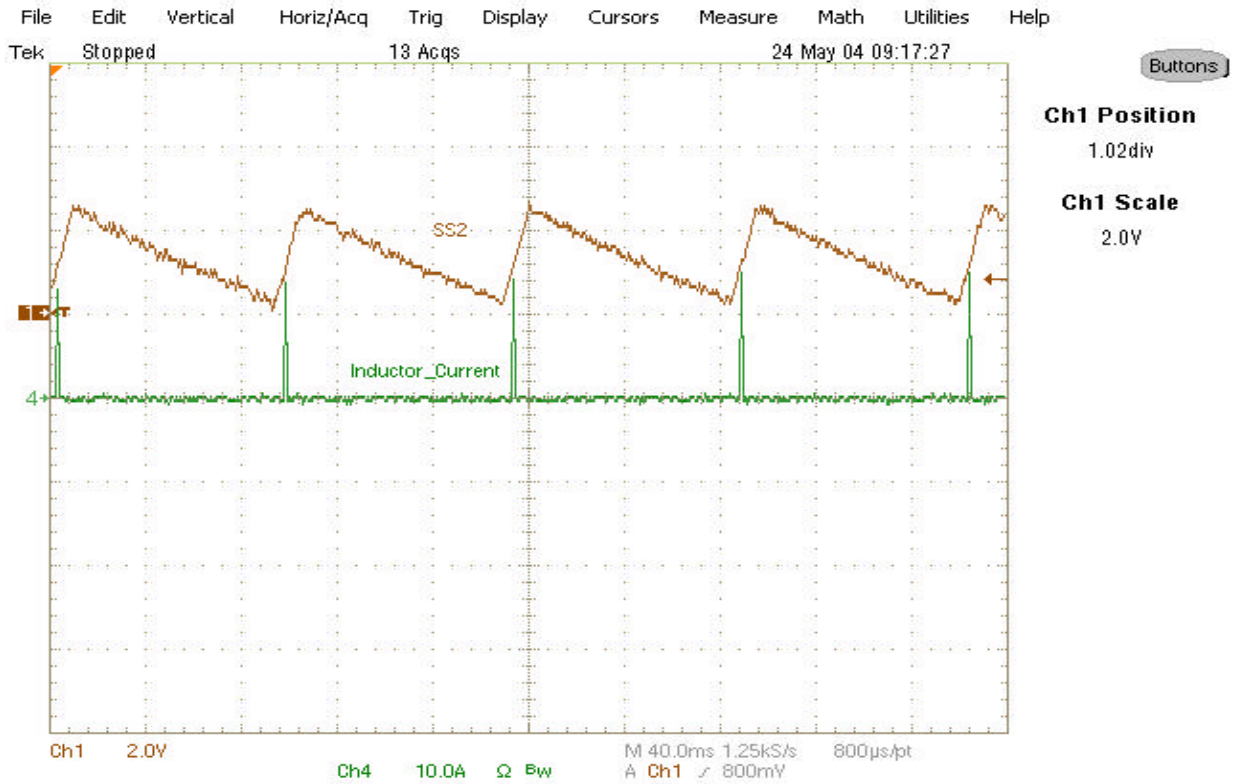

Figure 12- Short Circuit Condition (Hiccup Mode) for 1.8V Output

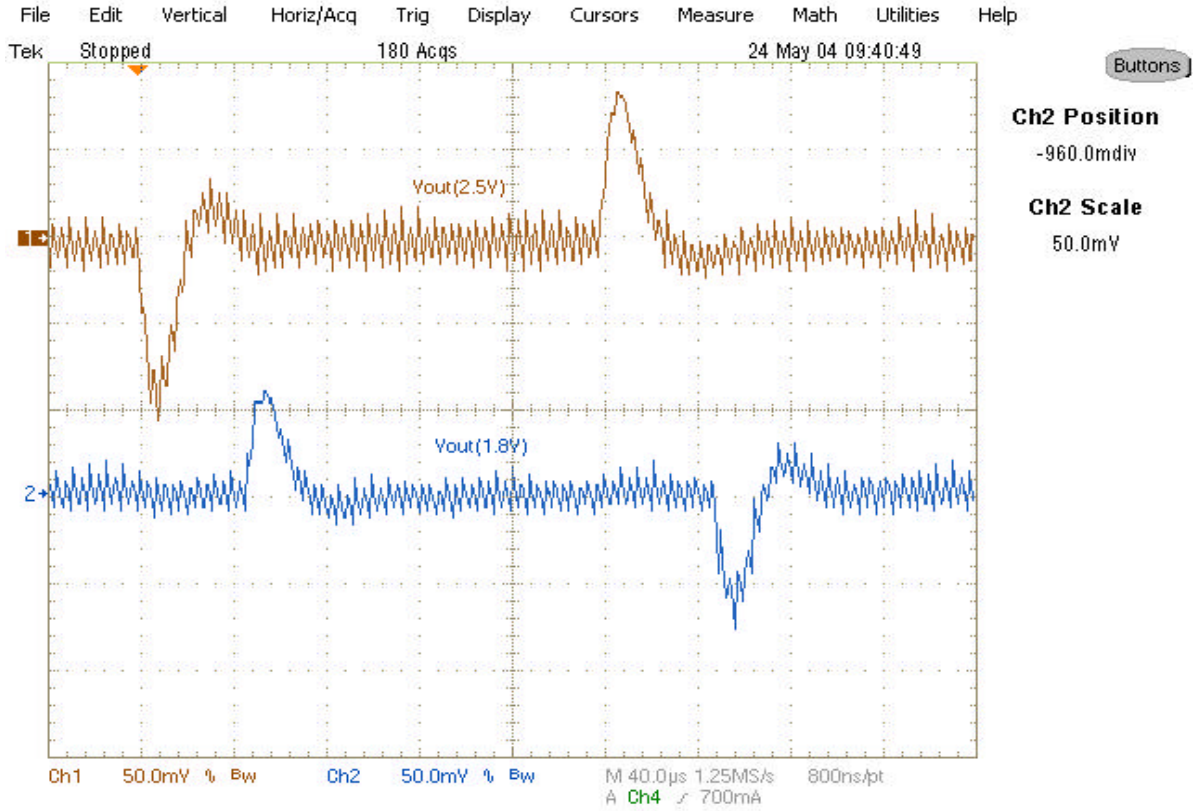

Figure 12- Load Transient Response
Step Load for 2.5V (0-10A)
Step Load for 1.8V (0-7A)

IRF7821/8113_12V_1.8V_2.5V_0_15A
Room Temp

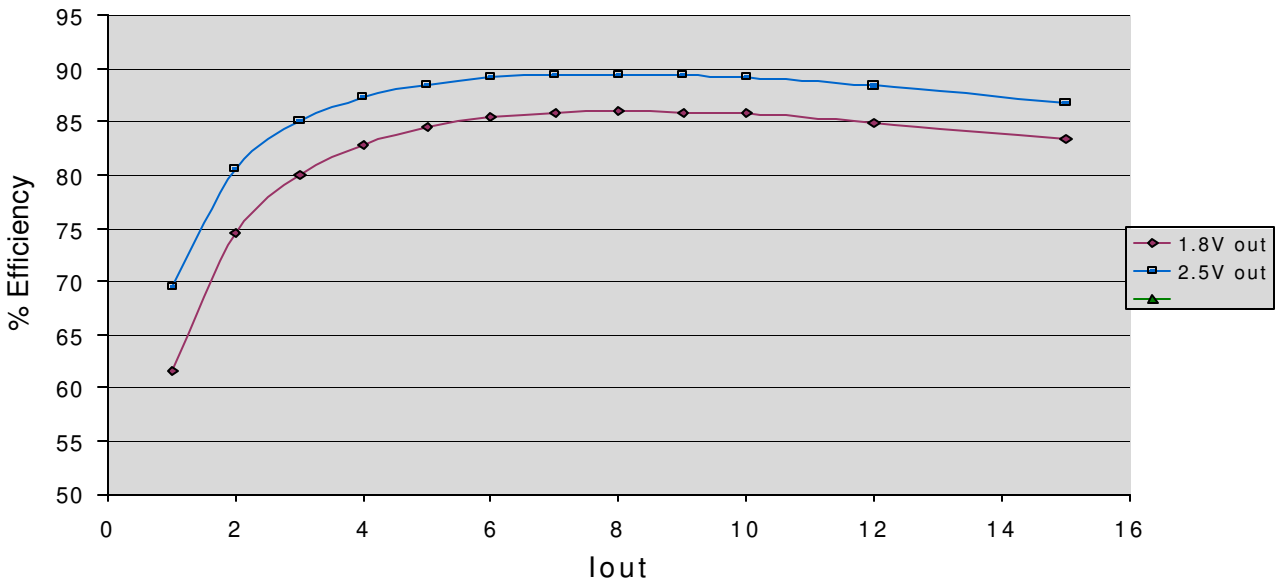
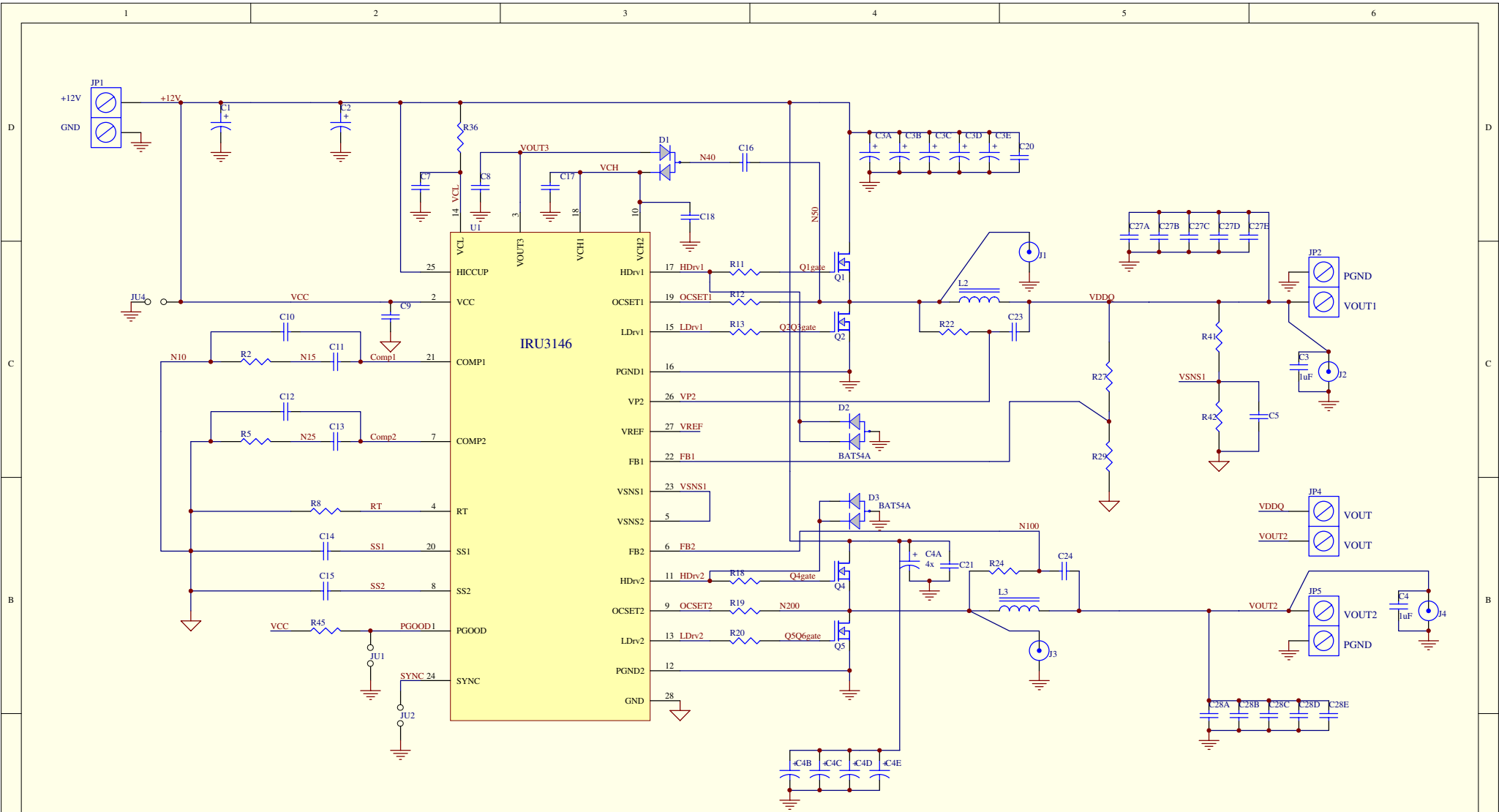

Figure 13- Efficiency for 2.5V and 1.8V outputs at room temperature no air flow.
L2=L3=2.17uH @ 17A



2-Phase, Single Output

Title			IRU3146		
Size	Number	Revision			
B					
Date:	28-Jul-2004	Sheet of			
File:	C:\Old_Drv\pcb\PCB_last3.ddb	Drawn By:			

BILL OF MATERIAL For 2-Phase Application, Vin=12V, Vout=1.8V@35A

Ref Desig	Description	Value	Qty	Part#	Manuf
Q1,Q4	DirectFET	30V,9mOhm	2	IRF6617	IR
Q2,Q5	DirectFET	30V,4mOhm	2	IRF6618	IR
U1	Controller	Synchronous PWM	1	IRU3146	IR
D1	Diode	Fast Switching	1	BAT54S	IR
D2,D3	Diode	Fast Switching	2	BAT54A	IR
L2,L3	Inductor	0.8μH,27A,1.56mΩ	2	ETQP1H1ROBFA	Panasonic
C1,C2,C3A-E, C4A-E	Cap, Poscap	47μF, 16V	12	16TPQC47M	Sanyo
C27A-E, C28A-E	Cap, Ceramic	330μF,6.3V,40mOhm	10	6TPB330M	Sanyo
C14,C16	Cap, Ceramic	0.1μF, Y5V, 25V	2	ECJ-2VF1E104Z	Panasonic
C17,C18	Cap, Ceramic	1μF, X7R, 25V	2	ECJ-3YB1E105K	Panasonic
C3,C4,C5,C7,C8,C9,C20,C21,C23,C24	Cap, Ceramic	1μF, Y5V, 16V	10	ECJ-2VF1C105Z	Panasonic
C10,C12	Cap, Ceramic	100pF, X7R, 50V	2	ECJ-2VC1H100J	Panasonic
C11,C13	Cap, Ceramic	15nF, X7R, 50V	2	ECU-V1H153KBG	Panasonic
R2	Resistor	5.11K,1%	1		
R5	Resistor	6.8K,1%	1		
R8	Resistor	33K,1%	1		
R12,R19	Resistor	5K, 1%	2		
R22,R24,R29,R42	Resistor	1K, 1%	4		
R27,R41	Resistor	1.24K, 1%	2		
R36		100Ω	1		
R3,6,7,11,13,18,20,35,10,16,17,23	Resistor	Short, 0Ω	12		
R1,4,37,38,9,25,26,34,28,43,44,30,31,33,32	Resistor	Open	15		
R14,R21,R39,R40,R15	Resistor	Open	5		
C19,22,25,26,6,19	Capacitor	Open	6		
C15	Capacitor	Short	1		
Q9,Q10	Transistor	Open	2	131-5031-00	Tektronix
J1,J2,J3,J4	Scope Probe	2-Pos terminal	4	ED1973-ND	Digi-Key
JP1,JP4	Terminal		2	S1012-02-ND	Digi-Key
JU1,JU2,JU3,JU4,JU5	Jumper		4		