

ATLANTIC VERSION TERMINATOR INTERFACE ADAPTER	PART NUMBER	REVISION	DESCRIPTION	FEED TYPE	APPLICATOR STYLE CONVERSION CHART						
					CONVERT TO	PART NUMBERS REQUIRED					
	2266146-2	B	FINE CRIMP HEIGHT ADJUST	PNEUMATIC	-	-	-	-	-	-	
	2266146-5	B	FINE CRIMP HEIGHT ADJUST	SERVO LATCH PLATE ⁴	SERVO LATCH PLATE	2119951-1	-	8-2266146-5	1901094-3	-	2168400-6 (QUANTITY 2)
	2266146-6	B	NON-CRIMP HEIGHT ADJUST	SERVO LATCH PLATE ⁴	SMART APPLICATOR	2161326-1	-	8-2266146-4	-	-	-
	2266146-7	B	FINE CRIMP HEIGHT ADJUST	NONE	-	-	-	-	-	-	-
	7-2266146-7	A	CRIMP TOOLING KIT	-	-	-	-	-	-	-	-

APPLICATOR DATA		
CRIMP	SIZE	TYPE
WIRE	3.98 mm [.157]	F
INSUL	5.90 mm [.232]	O

APPLICATOR INSTRUCTIONS
408-10389

TERMINAL DATA: LEAR TERMINAL		TE CRIMP SPECIFICATION	
TERMINAL NAME: TERMINAL			
WIRE STRIP LENGTH		INSULATION DIAMETER RANGE	
6.50-7.50 mm [.256-.295 IN]		Ø4.50-6.00 mm [.177-.236 IN]	
TERMINAL APPLICATION SPECIFICATION	LEAR-28141	REVISION	3
TERMINALS APPLIED ¹⁰ ¹²			
TE TERMINAL	LEAR TERMINAL	TE TERMINAL	LEAR TERMINAL
2113405-1	28141.201.178		

WIRE SIZE	CRIMP HEIGHT mm [INCH]	CRIMP HEIGHT REFERENCE SETTING
(4)1.00	3.05+/-0.05 [.120+/- .002]	4.7
(2)0.75 + 1.00 + 1.50	3.05+/-0.05 [.120+/- .002]	4.7
(3)0.75 + 1.50	3.00+/-0.05 [.118+/- .002]	5.6
(3)1.00	2.95+/-0.05 [.116+/- .002]	6.3
(2)0.75 + 1.00	2.80+/-0.05 [.110+/- .002]	8.0

- ¹ RECOMMENDED SPARE PARTS
- ² GREASE BEARING SURFACES LIGHTLY
- 3. LUBRICATE DAILY PER THE APPLICATOR INSTRUCTION SHEET SUPPLIED WITH THE APPLICATOR.
- ⁴ APPLICATOR SPECIFIC DATA TO BE ENTERED INTO BLANK MEMORY CHIP AT ASSEMBLY. SEE BELOW FOR PART NUMBER:
 PNEUMATIC FEED WITH "SMART APPLICATOR" CONVERSION: 8-2266146-4
 SERVO FEED WITH "FINE CRIMP HEIGHT ADJUST": 8-2266146-5
 SERVO FEED WITH "NON-CRIMP HEIGHT ADJUST": 8-2266146-6
- 5. ADJUSTMENT OF THE STRIPPER MAY BE REQUIRED WHEN MOVING THE APPLICATOR BETWEEN BENCH AND LEADMAKER APPLICATIONS.
- ⁶ APPLY PART NUMBER 1-23419-5 LOCTITE TO THREADS OF ITEM 62. APPLY PART NUMBER 2-23419-6 TO THREADS OF ITEM 242. FOR -6 ONLY APPLY PART NUMBER 1-23419-5 LOCTITE TO THREADS OF ITEM 37.
- ⁷ GREASE THREADS, GROOVE AND O-RING ON ITEMS 35 & 252.
- ⁸ MAGNET, ITEM 166 MUST BE ORIENTED CORRECTLY IN ORDER TO PROPERLY ACTUATE THE COUNTER.
- ⁹ CRIMP HEIGHT REFERENCE SETTING WAS THE SETTING USED WHEN THE APPLICATOR WAS QUALIFIED AT THE FACTORY. ADJUSTMENT MAY BE NECESSARY WHEN RUNNING APPLICATOR IN THE FIELD.
- ¹⁰ TERMINAL PITCH NOT COMPATIBLE WITH MECHANICAL FEED.
- ¹¹ WHEN ASSEMBLING A NON CRIMP HEIGHT ADJUST APPLICATOR (-6) USE SHIMS FROM ITEM 260 TO ACHIEVE A NOMINAL SHIM HEIGHT OF 2.75.
- ¹² TERMINAL LUBRICANT IS RECOMMENDED.

***WARNING**
 ON INSTALLATION, SET WIRE DISC, ITEM 40 TO LARGEST WIRE SIZE SETTING. USE OF SETTINGS BELOW MINIMUM REQUIRED CRIMP HEIGHT SETTING WILL CAUSE DAMAGE TO CRIMP TOOLING.

ATLANTIC VERSION
 Shown on sheets 1 of 4 & 2 of 4
 (Pacific version shown on sheets 3 of 4 & 4 of 4)

SET UP GAUGE	LOC	DIST	REVISIONS					
2119599-1	A	66	P	LTN	DESCRIPTION	DATE	OWN	APVD
			A		RELEASED	26FEB2014	KS	TE
			B		ECR-17-010458	19JUL2017	TB	TE

-	-	1	-	-	2119957-2	APPLICATOR SHIM PACK	260
-	1	1	1	1	1803078-1	SPACER, PRECISION	259
-	1	-	1	1	8-21084-0	O-RING, .676 ID, .070 DIA. MAT.	252
-	-	-	-	1	2119640-1	PUSH ROD, AIR FEED	250
-	-	-	-	1	1803259-1	BUSHING, FLANGED	249
-	-	-	-	1	2119641-1	FEED CAM, AIR FEED	248
-	1	-	1	1	2119798-1	DETENT PIN	247
-	1	-	1	1	1-22279-3	SPRING, COMPRESSION	246
-	-	1	-	-	2161314-1	RAM, STEPPED, ATLANTIC, SF, NON-ADJ	245
-	1	1	1	1	2119082-9	CAM, SWAIL, INSULATION ADJUSTMENT	244
-	1	1	1	1	2079764-1	WASHER, WAVE SPRING, CREST-TO-CREST	243
-	1	1	1	1	2119083-1	RETAINER, INSULATION DIAL	242
-	-	2	2	-	2168400-6	SHCS, LOW HEAD, RoHS, M5 X 16	240
-	-	-	-	1	2063440-2	AIR FEED MODULE	238
-	-	1	1	-	2119740-2	TAG, IDENTIFICATION	213
-	-	1	1	-	1901094-3	SPACER, FEEDER	198
-	-	-	-	2	21045-3	RING, RETAIN, EXTERN, 3/16 CRESCENT	172
-	1	1	1	1	994969-1	MAGNET, RARE EARTH HIGH ENERGY	166
-	REF	REF	REF	REF	994970-2	COUNTER, MAGNETIC	164
-	-	-	-	1	240638-1	SPRING, FEED FINGER	163
-	-	-	-	1	3-23627-7	PIN, RETAIN, GRVD, 3/16 X .854	137
-	-	-	-	1	2119799-1	HOLDER, FEED FINGER, AF	136
-	-	REF	REF	-	-	SEE NOTE 4	135
-	-	1	1	-	1633743-1	SERVO FEED LATCH ASM	133
-	1	1	1	1	1-18028-2	WASHER, FLAT, REG M4	119
-	-	REF	REF	-	2119944-1	FEED FINGER ASSEMBLY, SF	117
-	1	1	1	1	2119955-1	ASSY, LUBRICATOR, SIDE FEED	113
-	1	1	1	1	1-455888-4	SPACER, CRIMPER	82
-	1	1	1	1	2119956-1	DOCUMENTATION PACKAGE	71
-	1	-	-	1	2119740-1	TAG, IDENTIFICATION	67
-	2	2	2	2	2168078-1	SCREW, DRIVE, RH, RoHS, 2 x .188	66
-	1	-	-	1	2119793-1	LIMITER, ADJUSTMENT BOLT	63
-	3	-	3	3	992763-5	SCR, SET, SOC, CONE POINT, M3 x 4.0	62
-	1	1	1	1	2079383-4	SCR, BHSC, RoHS (M4 X 8)	60
-	-	-	-	1	5-18022-5	SCR, HEX HD CAP, M4 X 6.0	59
-	-	-	-	1	1338685-1	PAWL, FEED	56
-	2	2	2	2	2168400-1	SHCS, LOW HEAD, RoHS, M4 X 12	54
-	-	-	-	1	18023-9	SCR, SKT HD CAP M4 X 6.0	49
-	1	1	1	1	2119656-9	APPLICATOR BASIC ASSEMBLY, SF	46
-	1	-	-	1	2161311-1	RAM, STEPPED, AMP STYLE, SIDE FEED	44
-	1	1	1	1	1-2079383-5	SCR, BHSC, RoHS (M8 X 40)	41
-	1	-	-	1	2119645-1	DISC, NUMBERED FA WIRE ADJUSTMENT	40
-	1	-	-	1	2119957-1	APPLICATOR SHIM PACK	39
-	1	1	1	1	2119644-5	RAM WASHER, PRECISION	38
-	1	1	1	1	2119085-1	FA HEAD, ATLANTIC STYLE	37
-	1	-	-	1	2119092-1	BOLT, ADJUSTMENT	35
-	2	2	2	2	2079383-5	SCR, BHSC, RoHS (M4 X 20)	33
-	1	1	1	1	2161328-1	HEX HEAD, FLANGED, M5 x 8mm LONG	32
-	1	1	1	1	1320908-7	SPACER, STRIP GUIDE	30
-	1	1	1	1	2119959-4	ASSEMBLY, STRIP GUIDE	29
-	1	1	1	1	1-455888-0	SPACER, CRIMPER	28
-	1	1	1	1	240792-2	DRAG, TERMINAL	25
-	1	1	1	1	1320928-2	STRIP GUIDE	24
-	1	1	1	1	2168083-2	SCR, SKT HD CAP, RoHS, M4 X 8.0	21
-	1	1	1	1	1-18028-2	WASHER, FLAT, REG M4	20
-	1	1	1	1	2119533-1	STRIPPER, SIDE FEED	19
-	1	1	1	1	3-22280-3	SPRING, COMPRESSION	12
-	1	1	1	1	1-356885-3	STOP, SHEAR	11
-	1	1	1	1	2119805-1	SHEAR HOLDER, FRONT	10
-	1	1	1	1	6-454276-5	FLOATING SHEAR, FRONT	9
-	1	1	1	1	6-1633927-7	ANVIL, COMBINATION	8
-	-	-	-	-	-	-	7
-	-	-	-	-	-	-	6
-	1	1	1	1	1-2119757-3	DEPRESSOR, SHEAR	5
-	1	1	1	1	4-238011-9	BLOCK, CRIMPER SPACER	4
-	1	1	1	1	3-1803019-9	CRIMPER, INSULATION O	3
-	1	1	1	1	1-455888-7	SPACER, CRIMPER	2
-	1	1	1	1	1-1633588-3	CRIMPER, WIRE	1

DIMENSIONS:		TOLERANCES UNLESS OTHERWISE SPECIFIED:		MATERIAL:		FINISH:		WEIGHT:		SCALE:	
mm	0 PLC ±	1 PLC ±	2 PLC ±	3 PLC ±	4 PLC ±	ANGLES	FINISH				

OWN	CHK	DATE	NAME	SIZE	CAGE CODE	DRAWING NO	RESTRICTED TO
STAKEM	T. ELBIN	02NOV2013	Ocean Side Feed Applicator	A1	00779	2266146	

Customer Accessible Production Drawing SCALE 1:2 SHEET 1 OF 4 REV B

LOC		DIST		REVISIONS			
A	66	P	LTM	DESCRIPTION	DATE	OWN	APVD
		-		SEE SHEET 1			

FEED TYPE

PNEUMATIC

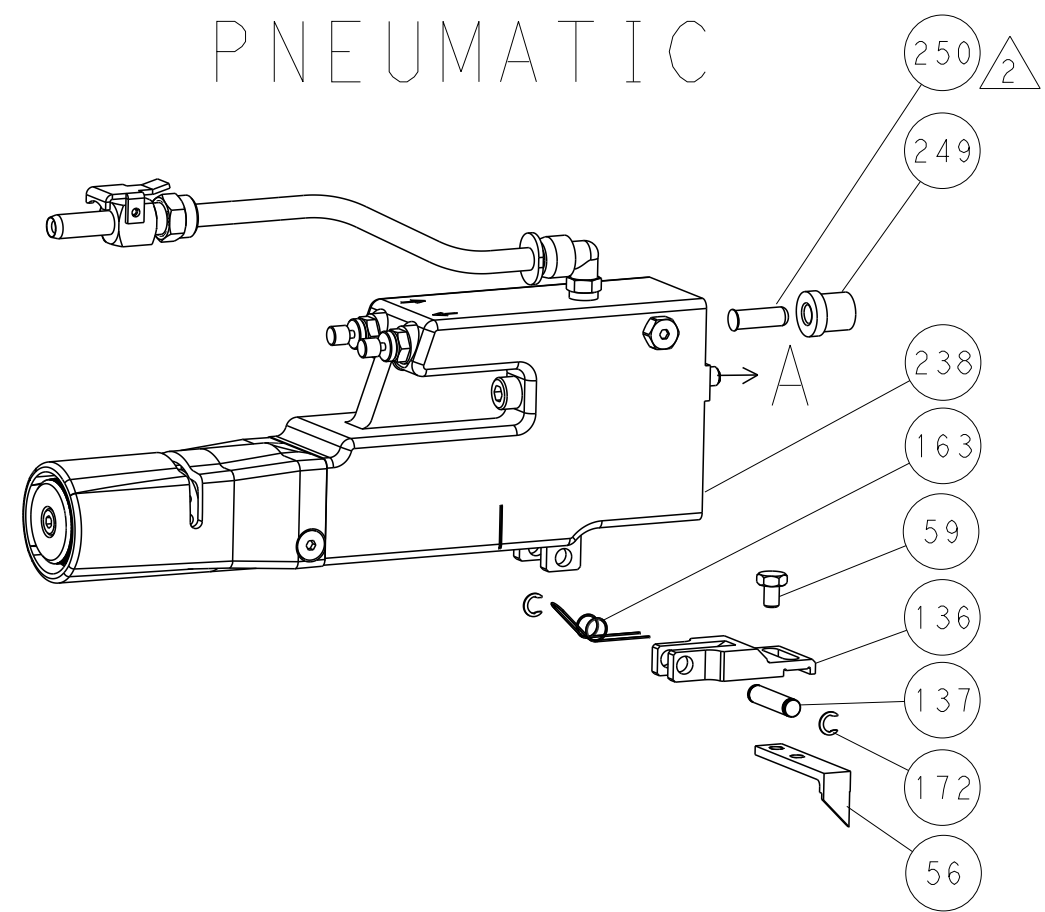

SERVO LATCH PLATE

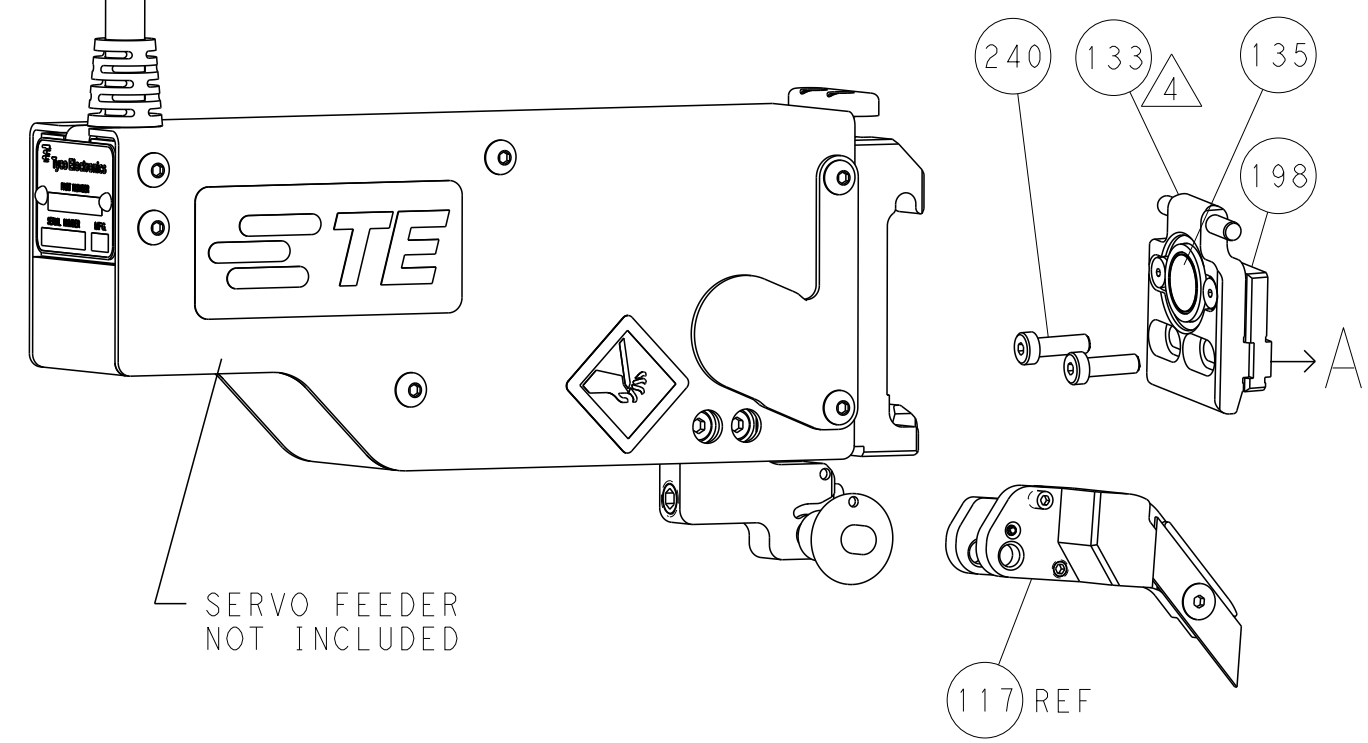

CAM POSITION

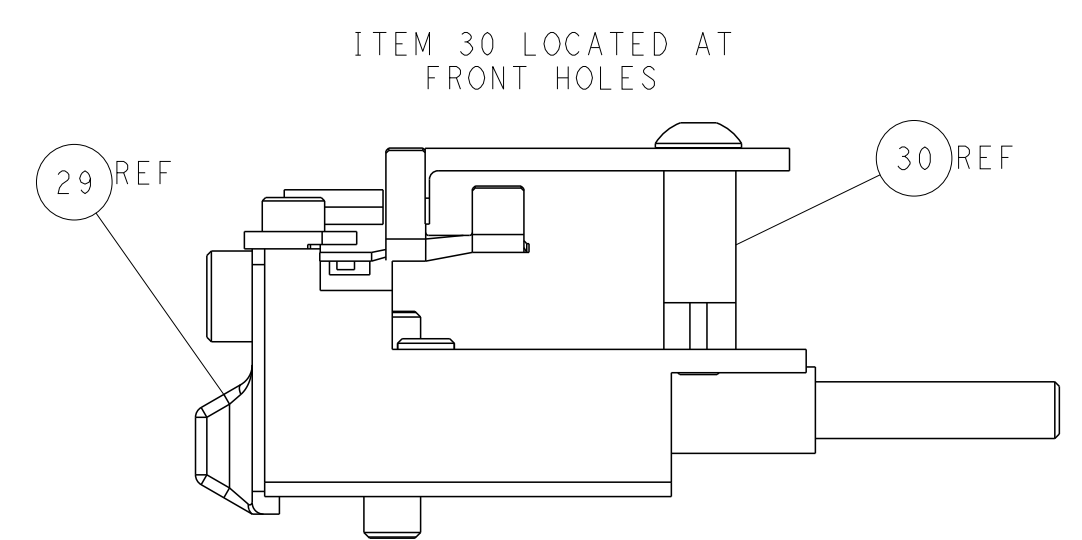
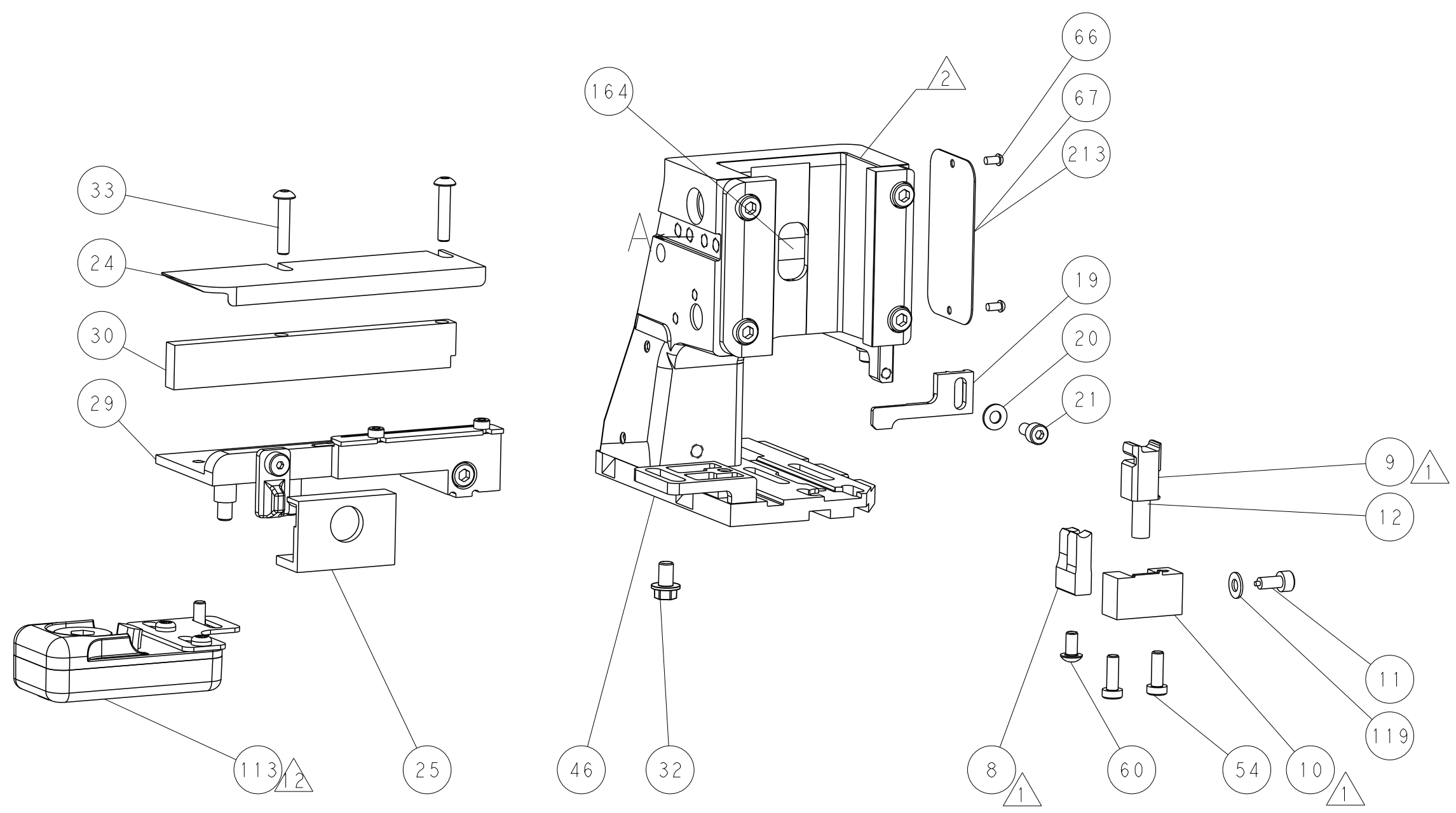
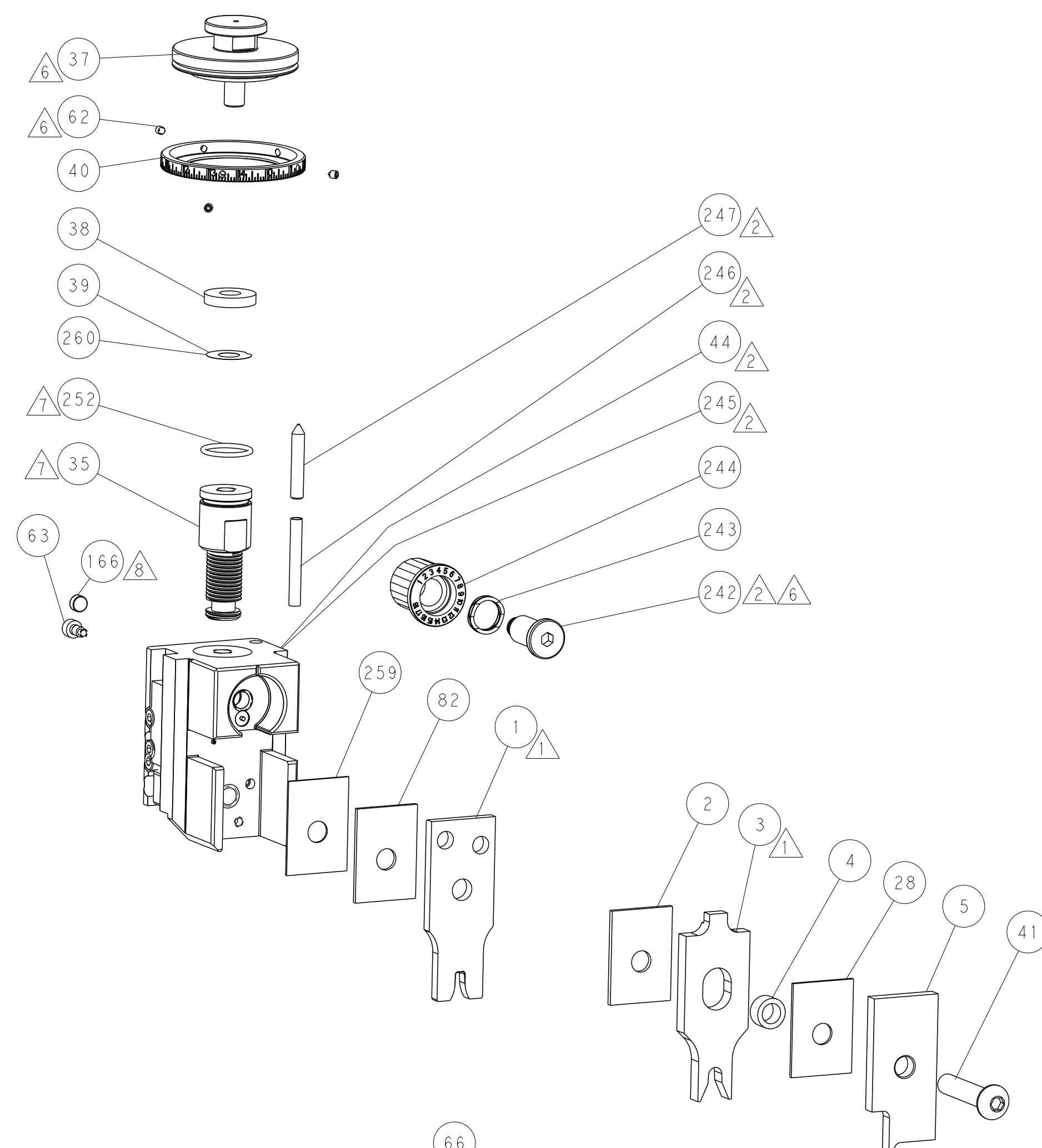
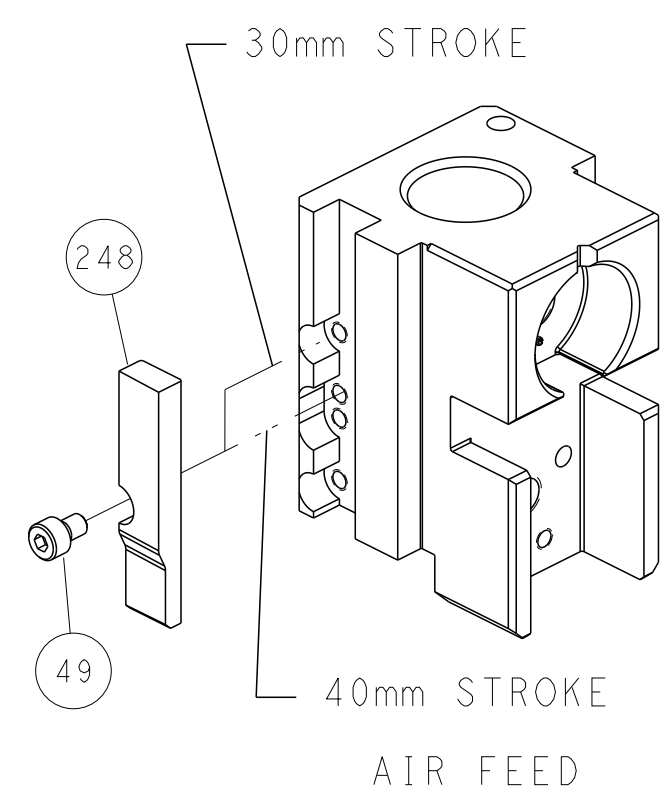

ATLANTIC VERSION
 Shown on sheets 1 of 4 & 2 of 4
 (Pacific version shown on sheets 3 of 4 & 4 of 4)

<small>THIS DRAWING IS UNPUBLISHED. RELEASED FOR PUBLICATION. IT IS THE PROPERTY OF TYCO ELECTRONICS CORPORATION. IT IS TO BE USED ONLY FOR THE PURPOSES AND IN THE MANNER AND UNDER THE RESTRICTIONS SPECIFIED HEREIN. IT IS TO BE RETURNED TO TYCO ELECTRONICS CORPORATION WHEN NO LONGER REQUIRED.</small>		DWN: R. STAKEM 02NOV2013 CHK: T. ELBIN 02NOV2013 APVD: G. BAILEY 02NOV2013	TE Connectivity Harrisburg, PA 17105-3608
DIMENSIONS: mm TOLERANCES UNLESS OTHERWISE SPECIFIED: 0 PLC ± 1 PLC ± 2 PLC ± 3 PLC ± 4 PLC ± ANGLES ° ± FINISH		NAME: Ocean Side Feed Applicator APPLICATION SPEC: - PRODUCT SPEC: - SCALE: 1:2	RESTRICTED TO: - SIZE: A1 CAGE CODE: 00779 DRAWING NO: C=2266146 SHEET 2 OF 4 REV B
MATERIAL: - FINISH: -		WEIGHT: - SCALE: 1:2	Customer Accessible Production Drawing

PACIFIC VERSION TERMINATOR INTERFACE ADAPTER	PART NUMBER	REVISION	DESCRIPTION	FEED TYPE	CONVERT TO	PART NUMBERS REQUIRED					
	2-2266146-2	B	FINE CRIMP HEIGHT ADJUST	PNEUMATIC	SERVO LATCH PLATE	2119951-1	-	8-2266146-5	1901094-3	-	2168400-6 (QUANTITY 2)
	2-2266146-5	B	FINE CRIMP HEIGHT ADJUST	SERVO LATCH PLATE ⁴	SMART APPLICATOR	2161326-1	-	8-2266146-4	-	-	-
	2-2266146-7	B	FINE CRIMP HEIGHT ADJUST	NONE	PNEUMATIC FEED	2119950-1	1338685-1	5-18022-5	2119641-2	2119799-1	2063440-2
	7-2266146-7	A	CRIMP TOOLING KIT	-	-	-	-	-	-	-	-

APPLICATOR DATA		
CRIMP	SIZE	TYPE
WIRE	3.98 mm [1.57]	F
INSUL	5.90 mm [2.32]	O
APPLICATOR INSTRUCTIONS 408-10389		

TERMINAL DATA: LEAR TERMINAL		TE CRIMP SPECIFICATION	
TERMINAL NAME: TERMINAL			
WIRE STRIP LENGTH		INSULATION DIAMETER RANGE	
6.50-7.50 mm [2.56-.295 IN]		Ø4.50-6.00 mm [1.77-.236 IN]	
TERMINAL APPLICATION SPECIFICATION	LEAR-28141	REVISION 3	-
TERMINALS APPLIED ¹⁰ ¹¹			
TE TERMINAL	LEAR TERMINAL	TE TERMINAL	LEAR TERMINAL
2113405-1	28141.201.178		

WIRE SIZE	CRIMP HEIGHT mm [INCH]	CRIMP HEIGHT REFERENCE SETTING
(4)1.00	3.05+/-0.05 [1.20+/- .002]	4.7
(2)0.75 + 1.00 + 1.50	3.05+/-0.05 [1.20+/- .002]	4.7
(3)0.75 + 1.50	3.00+/-0.05 [1.18+/- .002]	5.6
(3)1.00	2.95+/-0.05 [1.16+/- .002]	6.3
(2)0.75 + 1.00	2.80+/-0.05 [1.10+/- .002]	8.0

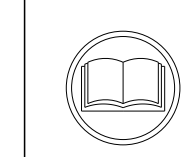

- ¹ RECOMMENDED SPARE PARTS
- ² GREASE BEARING SURFACES LIGHTLY
- 3. LUBRICATE DAILY PER THE APPLICATOR INSTRUCTION SHEET SUPPLIED WITH THE APPLICATOR.
- ⁴ APPLICATOR SPECIFIC DATA TO BE ENTERED INTO BLANK MEMORY CHIP AT ASSEMBLY. SEE BELOW FOR PART NUMBER:
PNEUMATIC FEED WITH "SMART APPLICATOR" CONVERSION: 8-2266146-4
SERVO FEED WITH "FINE CRIMP HEIGHT ADJUST": 8-2266146-5
- 5. ADJUSTMENT OF THE STRIPPER MAY BE REQUIRED WHEN MOVING THE APPLICATOR BETWEEN BENCH AND LEADMAKER APPLICATIONS.
- ⁶ APPLY PART NUMBER 1-23419-5 LOCITE TO THREADS OF ITEM 62.
APPLY PART NUMBER 2-23419-6 TO THREADS OF ITEM 242.
- ⁷ GREASE THREADS, GROOVE AND O-RING ON ITEMS 139 & 152.
- ⁸ MAGNET MUST BE ORIENTED CORRECTLY IN ORDER TO PROPERLY ACTUATE THE COUNTER.
- ⁹ CRIMP HEIGHT REFERENCE SETTING WAS THE SETTING USED WHEN THE APPLICATOR WAS QUALIFIED AT THE FACTORY. ADJUSTMENT MAY BE NECESSARY WHEN RUNNING APPLICATOR IN THE FIELD.
- ¹⁰ TERMINAL PITCH NOT COMPATIBLE WITH MECHANICAL FEED.
- ¹¹ TERMINAL LUBRICANT IS RECOMMENDED.

***WARNING**
ON INSTALLATION, SET WIRE DISC, ITEM 40 TO LARGEST WIRE SIZE SETTING. USE OF SETTINGS BELOW MINIMUM REQUIRED CRIMP HEIGHT SETTING WILL CAUSE DAMAGE TO CRIMP TOOLING.

PACIFIC VERSION
Shown on sheets 3 of 4 & 4 of 4
(Atlantic version shown on sheets 1 of 4 & 2 of 4)

SET UP GAUGE	LOC	DIST	REVISIONS					
2119599-1	A	66	P	LTN	DESCRIPTION	DATE	OWN	APVD
			-	-	SEE SHEET 1	-	-	-

-	1	1	1	1803078-1	SPACER, PRECISION	259
-	1	1	1	2119782-1	FINE ADJUST HEAD ASM, PACIFIC STYLE	251
-	-	-	1	2119640-1	PUSH ROD, AIR FEED	250
-	-	-	1	1803259-1	BUSHING, FLANGED	249
-	1	1	1	1-22279-3	SPRING, COMPRESSION	246
-	1	1	1	2119082-9	CAM, SNAIL, INSULATION ADJUSTMENT	244
-	1	1	1	2079764-1	WASHER, WAVE SPRING, CREST-TO-CREST	243
⁶	-	1	1	2119083-1	RETAINER, INSULATION DIAL	242
-	-	2	-	2168400-6	SHCS, LOW HEAD, RoHS, M5 X 16	240
-	-	-	1	2063440-2	AIR FEED MODULE	238
-	-	1	-	2119740-2	TAG IDENTIFICATION	213
-	-	1	-	1901094-3	SPACER, FEEDER	198
-	-	-	2	21045-3	RING, RETAIN, EXTERN, 3/16 CRESCENT	172
-	1	1	1	994969-1	MAGNET, RARE EARTH HIGH ENERGY	166
-	REF	REF	REF	994970-2	COUNTER, MAGNETIC	164
-	-	-	1	240638-1	SPRING, FEED FINGER	163
⁷	-	1	1	8-21084-1	O-RING, .801 ID, .070 DIA. MAT.	152
-	-	-	1	2119641-2	FEED CAM, AIR FEED	151
-	1	1	1	2119798-2	DETENT PIN	145
-	1	1	1	2079383-8	SCR, BHSC, RoHS (M4 X 16)	144
-	2	2	2	2168400-5	SHCS, LOW HEAD, RoHS, M4 X 20	143
-	1	1	1	1-2119656-0	APPLICATOR BASIC ASSEMBLY, SF	141
-	1	1	1	2161312-1	RAM, STEPPED, ASIAN STYLE, SIDE FEED	140
⁷	-	1	1	2119092-2	BOLT, ADJUSTMENT	139
-	-	-	1	3-23627-7	PIN, RETAIN, GRVD, 3/16 X .854	137
-	-	-	1	2119799-1	HOLDER, FEED FINGER, AF	136
-	-	REF	-	SEE NOTE 4	MEMORY CHIP, PROGRAMMED	135
-	-	1	-	1633743-1	SERVO FEED LATCH ASM	133
-	1	1	1	1-18028-2	WASHER, FLAT, REG M4	119
-	-	REF	-	2119944-1	FEED FINGER ASSEMBLY, SF	117
¹¹	-	1	1	2119955-1	ASSY, LUBRICATOR, SIDE FEED	113
-	1	1	1	1-455888-4	SPACER, CRIMPER	82
-	1	1	1	2119956-1	DOCUMENTATION PACKAGE	71
-	1	-	1	2119740-1	TAG IDENTIFICATION	67
-	2	2	2	2168078-1	SCREW, DRIVE, RH, RoHS, 2 x .188	66
-	1	1	1	2119793-1	LIMITER, ADJUSTMENT BOLT	63
⁶	-	3	3	992763-5	SCR, SET, SOC, CONE POINT, M3 X 4.0	62
-	-	-	1	5-18022-5	SCR, HEX HD CAP, M4 X 6.0	59
-	-	-	1	1338685-1	PAWL, FEED	56
-	-	-	1	18023-9	SCR, SKT HD CAP M4 X 6.0	49
-	1	1	1	1-2079383-5	SCR, BHSC, RoHS (M8 X 40)	41
-	1	1	1	2119645-1	DISC, NUMBERED FA WIRE ADJUSTMENT	40
-	1	1	1	2119957-1	APPLICATOR SHIM PACK	39
-	1	1	1	2119644-5	RAM WASHER, PRECISION	38
-	2	2	2	2079383-5	SCR, BHSC, RoHS (M4 X 20)	33
-	1	1	1	2161328-1	HEX HEAD, FLANGED, M5 X 8mm LONG	32
-	1	1	1	1320908-7	SPACER, STRIP GUIDE	30
-	1	1	1	1901086-1	PLATE, STRIP GUIDE	29
-	1	1	1	2119959-4	ASSEMBLY, STRIP GUIDE	29
-	1	1	1	1-455888-0	SPACER, CRIMPER	28
-	1	1	1	240792-2	DRAG, TERMINAL	25
-	1	1	1	1320928-2	STRIP GUIDE	24
-	1	1	1	2168083-2	SCR, SKT HD CAP, RoHS, M4 X 8.0	21
-	1	1	1	1-18028-2	WASHER, FLAT, REG M4	20
-	1	1	1	2119533-1	STRIPPER, SIDE FEED	19
-	1	1	1	3-22280-3	SPRING, COMPRESSION	12
-	1	1	1	1-356885-3	STOP, SHEAR	11
¹	-	1	1	2119805-1	SHEAR HOLDER, FRONT	10
¹	-	1	1	6-454276-5	FLOATING SHEAR, FRONT	9
¹	1	1	1	6-1633927-7	ANVIL, COMBINATION	8
-	-	-	-	-	-	7
-	-	-	-	-	-	6
-	1	1	1	1-2119757-3	DEPRESSOR, SHEAR	5
-	1	1	1	4-238011-9	BLOCK, CRIMPER SPACER	4
¹	1	1	1	3-1803019-9	CRIMPER, INSULATION O	3
-	1	1	1	1-455888-7	SPACER, CRIMPER	2
¹	1	1	1	1-1633588-3	CRIMPER, WIRE	1

DATE	BY	DESCRIPTION	ITEM NO
02NOV2013	STAKEM	TE Connectivity	
02NOV2013	ELBIN	Harrisburg, PA 17105-3608	
02NOV2013	BALLEY		

DIMENSIONS:	TOLERANCES UNLESS OTHERWISE SPECIFIED:	APVD	PRODUCT SPEC	APPLICATION SPEC	SIZE	CAGE CODE	DRAWING NO	RESTRICTED TO
mm	0 PLC ± 1 PLC ± 2 PLC ± 3 PLC ± 4 PLC ± ANGLES ±	6			A1	00779	2266146	
MATERIAL:	FINISH:	WEIGHT:						

Customer Accessible Production Drawing SCALE 1:2 SHEET 3 OF 4 REV B

LOC		DIST		REVISIONS			
A	66	P	LTM	DESCRIPTION	DATE	DWN	APVD
		-		SEE SHEET 1			

FEED TYPE PNEUMATIC

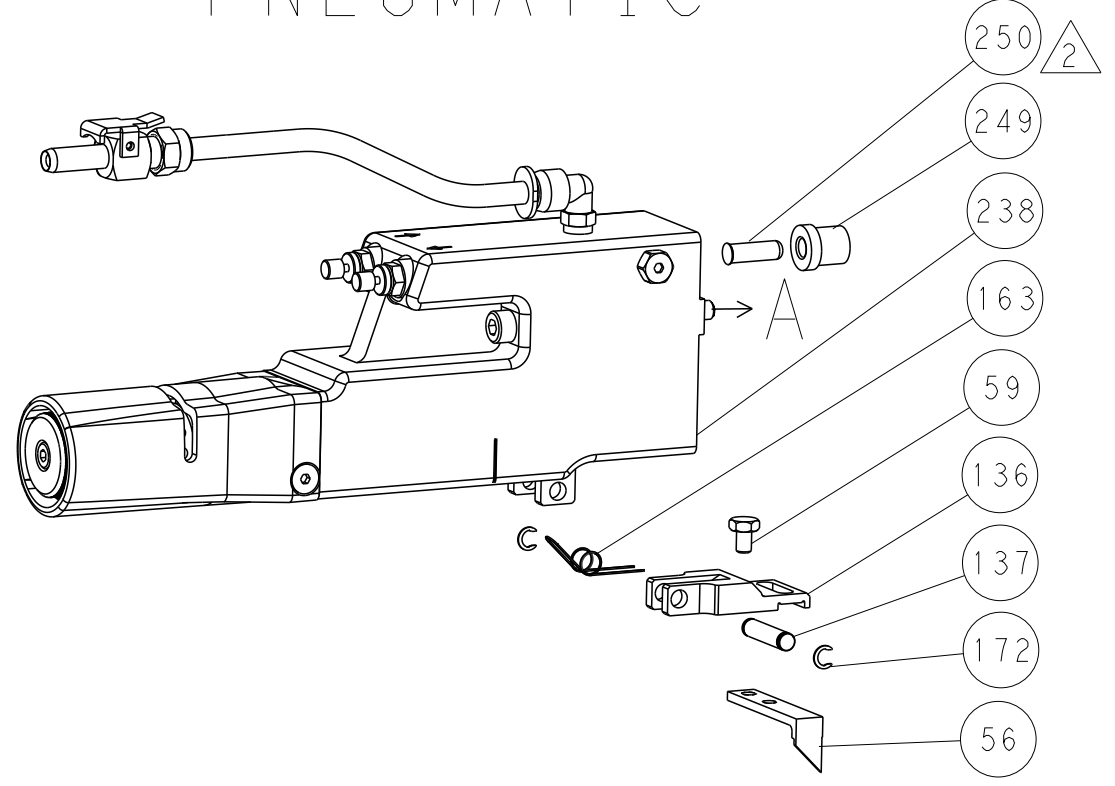

SERVO LATCH PLATE

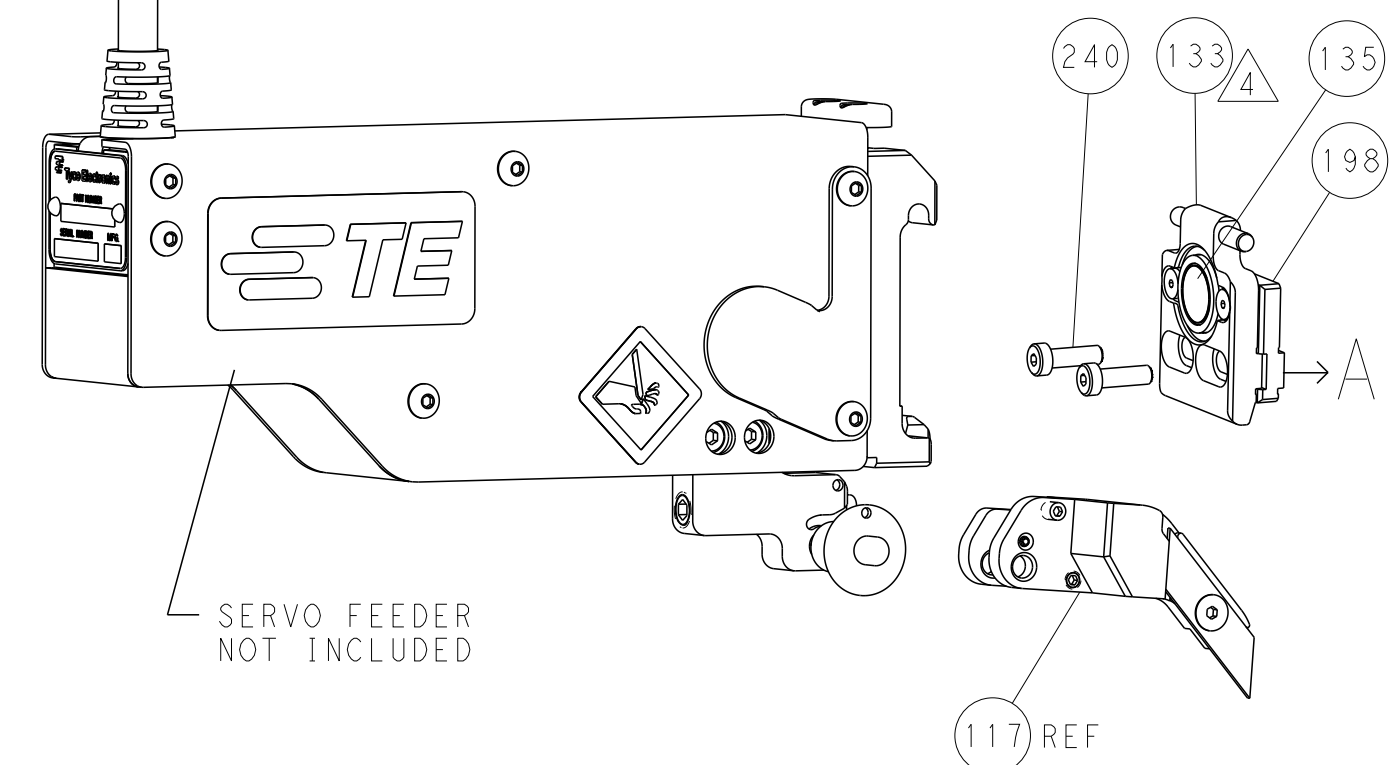

CAM POSITION

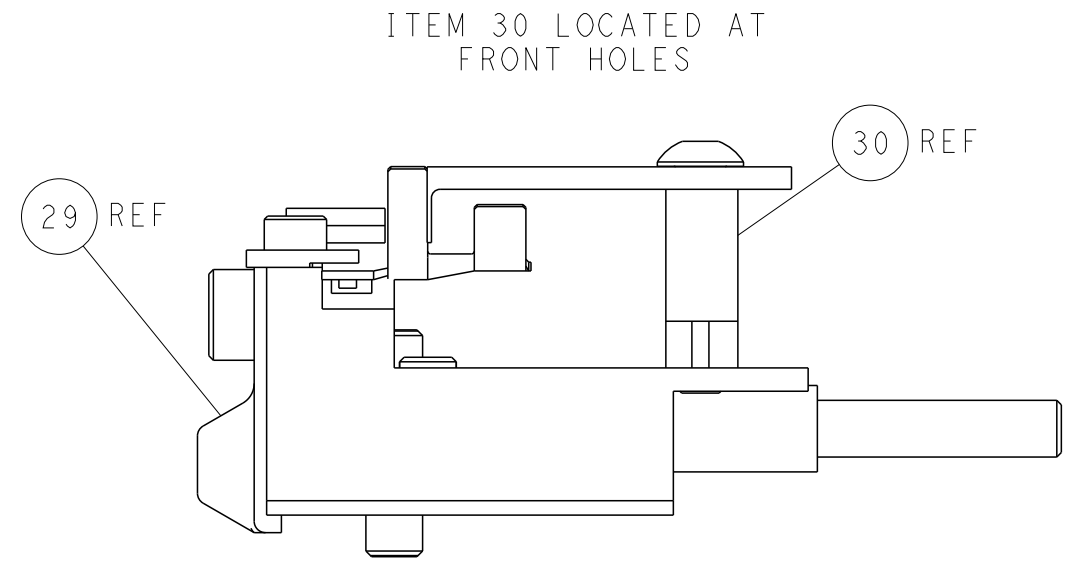
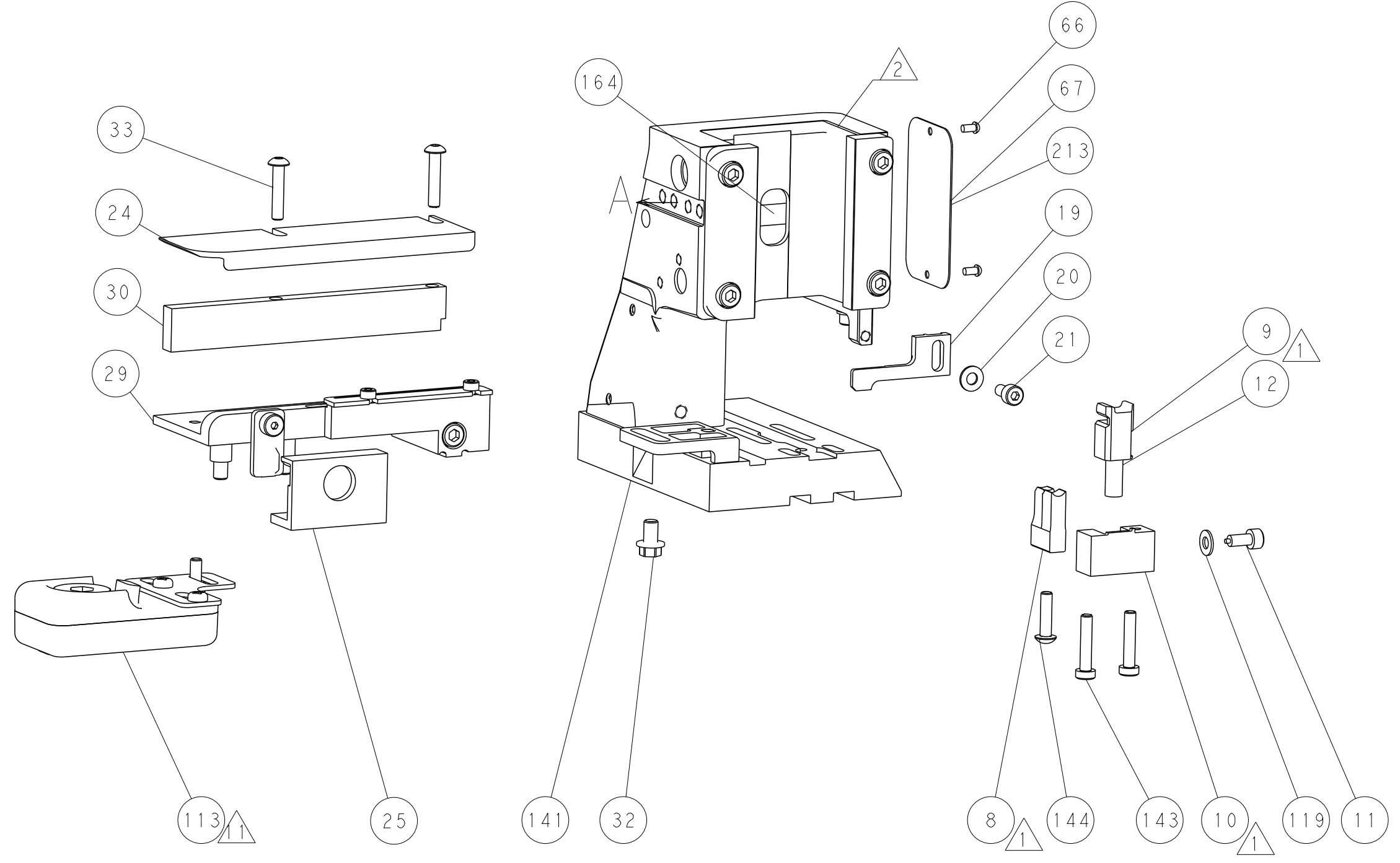
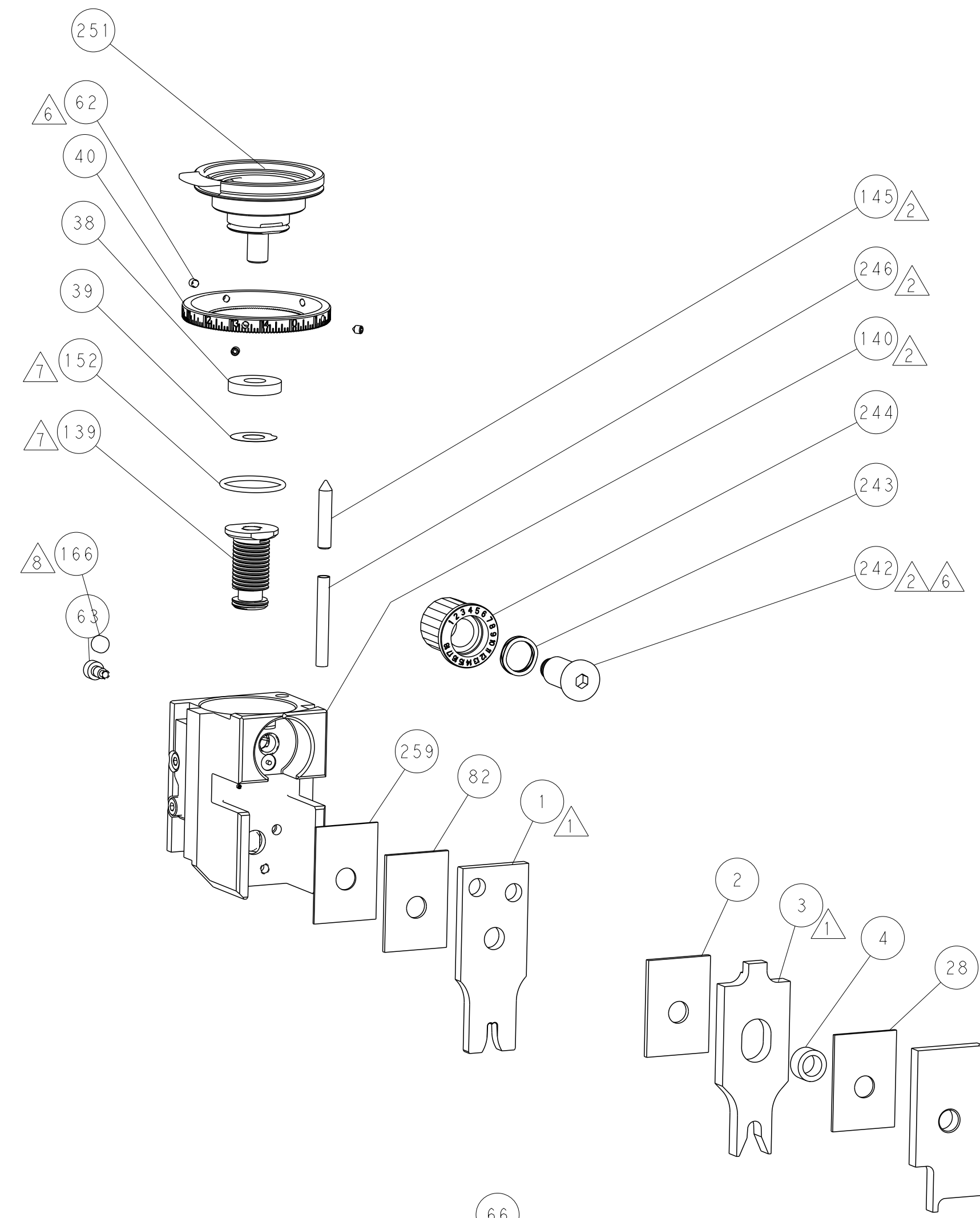
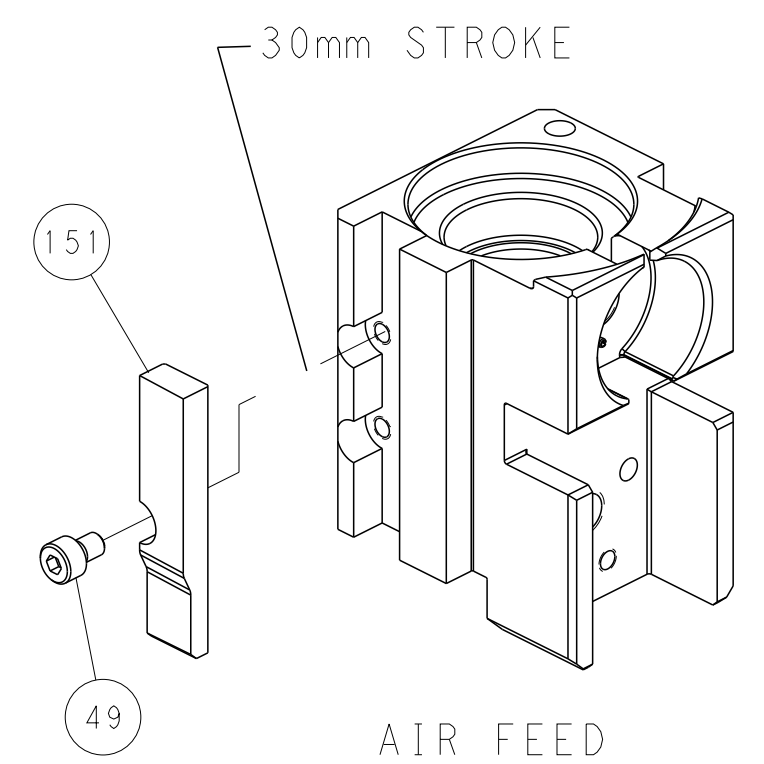

PACIFIC VERSION
 Shown on sheets 3 of 4 & 4 of 4
 (Atlantic version shown on sheets 1 of 4 & 2 of 4)

DIMENSIONS:		TOLERANCES UNLESS OTHERWISE SPECIFIED:		DWN: R. STAKEM 02NOV2013		CHK: T. ELBIN 02NOV2013		NAME: STE TE Connectivity Harrisburg, PA 17105-3608	
mm	0 PLC ±	1 PLC ±	2 PLC ±	3 PLC ±	4 PLC ±	APVD: G. RAILLY 02NOV2013	PRODUCT SPEC	Ocean Side Feed Applicator	
MATERIAL:	FINISH:	WEIGHT:	SCALE: 1:2	SHEET: 4	OF: 4	REV: B	Customer Accessible Production Drawing		