



Z8F04A28100KITG

**Z8 Encore! XP[®] F042A Series
Development Kit**

User Manual

UM016608-0608

Revision History

Each instance in the following table reflects a change to this document from its previous revision. To see more detail, click the appropriate link in the table.

| Date | Revision Level | Description | Page No |
|---------------|----------------|---|---------------------------|
| June 2008 | 08 | Updated Hardware section. | 1 |
| May 2008 | 07 | Removed Registration Card from Documentation . | 2 |
| | | Added Z8F042ASJ020 to the Introduction section. | 1 |
| March 2008 | 06 | Changed document title to Z8 Encore! XP [®] F042A Series Development Kit. | All |
| | | Modified Table 2 in Schematics to incorporate changes to R15 from 220 Ohm to 0 Ohm. Added Note 3 to the Schematics. | 10, 11 |
| February 2008 | 05 | Updated document with new Zilog logo and text. Updated document disclaimer. Implemented Style Guide. | All |
| December 2006 | 04 | Changed Figure 14 to Figure 2. Updated schematics. | 5, 10 |
| August 2006 | 03 | Removed Serial from Serial Smart Cable. | 1 |
| October 2005 | 02 | Updated schematic to reflect board revision C. Added 20 MHz clock information, and updated power supply circuit. | 6, 10, 11 |

FCC Statement

This device complies with part 15 of the FCC Rules. Operation is subject to the following two conditions:

1. This device may not cause harmful interference.
2. This device must accept any interference received, including interference that may cause undesired operation.

Safeguards

The following precaution must be observed when working with the devices described in this document:



Caution: *Always use a grounding strap to prevent damage resulting from electrostatic discharge (ESD).*

Table of Contents

| | |
|---|-----------|
| Introduction | 1 |
| Kit Contents | 1 |
| Hardware | 1 |
| Software (on CD-ROM) | 1 |
| Documentation | 2 |
| System/Software Requirements | 3 |
| Supported Host System Configuration | 3 |
| Installation | 4 |
| Z8 Encore! XP[®] F042A Series | |
| Development Board | 5 |
| Features | 6 |
| Z8 Encore! XP F042A Series MCU | 6 |
| UART with IrDA Endec | 8 |
| Power and Communication Interfaces | 8 |
| External Interface Headers JP1 and JP2 | 8 |
| Schematics | 9 |
| Customer Support | 12 |

Introduction

Zilog's Z8 Encore! XP[®] F042A Series MCU is the part of the line of Zilog[®] microcontroller products. The Z8 Encore! XP MCU Development Kit (Z8F04A28100KITG) allows you to get familiar with the hardware and software tools available with this product. This kit consists of the 4 KB version of the Z8 Encore![®] Development Board that supports and presents the features of the Z8 Encore! XP F042A Series. This kit allows you to write application software and contains all supporting documents.

Z8F042ASJ020 is the silicon used in the board. For more details, refer to *Z8 Encore! XP[®] F0823 Series Product Specification (PS0243)* available for download at www.zilog.com.

This manual acquaints you with the Z8 Encore! XP F042A Series MCU Development Kit and provides instructions on setting up and using the tools to start building designs and applications.

Kit Contents

The Z8 Encore! XP F042A Series MCU Development Kit contains the following:

Hardware

The hardware in Z8 Encore! XP F042A Series Development Kit includes:

- Z8 Encore! XP F042A Series Development Board
- USB Smart Cable for PC to Z8 Encore! XP[®] F042A series development board (previous versions of the development kit used a Serial Smart Cable. Refer your original documentation for information on using the Serial Smart Cable).
- 5 V DC power supply

Software (on CD-ROM)

The software on CD-ROM provided with Z8 Encore! XP F042A Series Development Kit includes:

- ZDS II-Z8 Encore![®] IDE with ANSI C-Compiler
- Sample code
- Document browser
- Acrobat Reader[®]



Figure 1. Z8 Encore! XP F042A Series Development Kit Contents

Documentation

- Quick Start Guide
- Z8 Encore! XP F042A Series technical documentation (on CD-ROM):
 - Development Kit User Manual
 - ZDS II - IDE User Manual
 - eZ8[™] CPU User Manual

The sample code is installed with ZDS II and resides in the <installation directory>\samples in the disk drive.

The documentation can be installed with the DemoShield interface or can be viewed on the CD-ROM using the DemoShield menus and a PDF reader. A copy of the Acrobat installer is provided on the CD-ROM and can be installed from the DemoShield install screen. After installing the documentation, Windows Explorer can be used to select any document to be viewed with the PDF file viewer.

System/Software Requirements

An IBM PC (or compatible computer) with the following minimum configuration:

Supported Host System Configuration

- Win98 Second Edition/ WinNT 4.0 Service Pack 6/ Win2000 Service Pack 3/ WinXP Professional Service Pack 1
- PentiumII/233 MHz processor or higher up to Pentium IV, 2.8 GHz
- 96 MB RAM or more
- 25 MB hard disk space or more
- Super VGA video adapter



- CD-ROM
- One or more RS-232 communication ports

Installation

Follow the instructions in the Quick Start Guide for software installation and setup of the Z8 Encore! XP[®] F042A Series Development Kit.

Z8 Encore! XP[®] F042A Series Development Board

The Z8 Encore! XP F042A Series Development Board is a development and prototyping board for the Z8 Encore! XP F042A Series MCU. The board provides a tool to evaluate features of Z8 Encore! XP F042A Series MCU and to start developing an application before building the hardware.

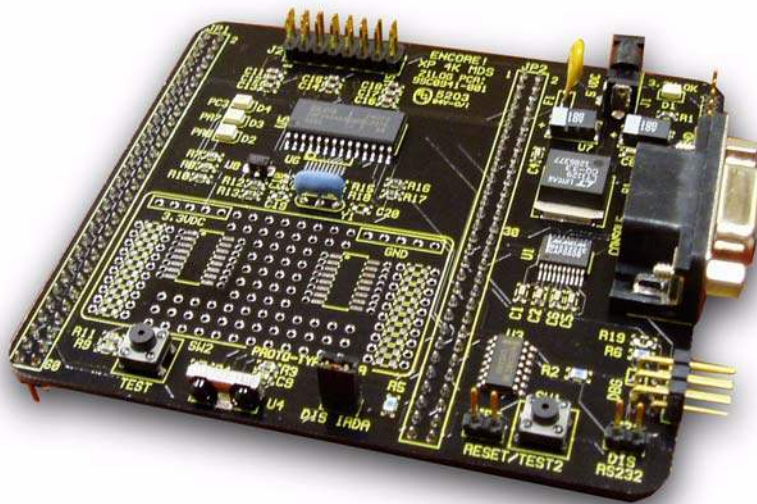

Figure 2. Z8 Encore! XP F042A Series Development Board

Features

The features of Z8 Encore! XP F042A Series Development Board include:

- Z8 Encore![®] MCU (28-pin SOIC)
- 3 LEDs
- RS-232 interface
- IrDA transceiver
- Two pushbuttons, RESET and TEST
- 5 V DC power connector
- On-Chip Debugger interface
- 20 MHz Crystal (Y1)
- Header for ADC input
- Prototyping area
- External interface connectors JP1 and JP2
- 2.7 V to 3.6 V operating voltage with 5 V-tolerant inputs

Z8 Encore! XP F042A Series MCU

The Z8 Encore! XP F042A Series MCU is member of a family of Zilog[®] microcontroller products based on the 8-bit eZ8[™] core CPU. The Flash in-circuit programming capability allows for faster development time and program changes in the field. The eZ8 core CPU is upward compatible with existing Z8[®] instructions. The rich peripheral set of the Z8 Encore! XP F042A Series makes it suitable for various applications including motor control, security systems, home appliances, personal electronic devices, and sensors.

The Development Board contains circuitry to support and present all the features of the Z8 Encore! XP F042A Series. The main features of the Z8 Encore! XP F042A Series include:

- eZ8 core CPU
- 4 KB Flash memory with in-circuit programming capability
- 1 KB register RAM
- 5-channel, 10-bit Analog-to-Digital Converter (ADC)
- Full-duplex UART
- I²C interface (Master Mode only)
- Serial Peripheral Interface (SPI)
- Infrared Data Association (IrDA)-compliant infrared encoder/decoder
- Two 16-bit timers with capture, compare, and PWM capability
- Watchdog Timer (WDT) with internal RC oscillator
- Eleven (20-pin package) or nineteen (28-pin package) I/O pins
- Programmable priority interrupts
- On-Chip Debugger (OCD)
- Voltage Brownout Protection (VBO)
- Power-On Reset (POR)
- 2.7 V to 3.6 V operating voltage with 5 V-tolerant inputs
- Operating temperatures: 20 °C ±10 °C

For more information on the Z8 Encore! XP family of devices, refer to *Z8 Encore! XP[®] F0823 Series Product Specification (PS0243)* available for download at www.zilog.com.

UART with IrDA Endec

The Z8 Encore! XP F042A Series (component U5) contains a fully-functional, high-performance UART with Infrared Encoder/Decoder (ENDEC). The Infrared Endec is integrated with an on-chip UART allowing easy communication between the Z8 Encore! XP F042A Series and IrDA transceivers. Infrared communication provides secure, reliable, low-cost, point-to-point communication between PCs, PDAs, cell phones, printers and other infrared enabled devices.

Power and Communication Interfaces

[Table 1](#) provides jumper information concerning the shunt status, functions, devices and defaults affected of jumpers JP3 and JP4.

Table 1. Jumpers JP3 and JP4

| Jumper | Status | Device Affected | Status | Default |
|---|--------|-----------------------------------|--|---------|
| JP3* | OUT | RS-232 interface | Enabled | X |
| JP3 | IN | RS-232 interface | Disabled | |
| JP4* | OUT | IrDA interface | Enabled | |
| JP4 | IN | IrDA interface | Disabled | X |
| JP5 | OUT | U5 $\overline{\text{RESET}}$ /PD0 | PD0 (GPIO) | X |
| JP5 | IN | U5 $\overline{\text{RESET}}$ /PD0 | $\overline{\text{RESET}}$ when SW1 pressed | |
| * These jumpers must not be OUT at the same time. | | | | |

External Interface Headers JP1 and JP2

External interface headers JP1 and JP2 are displayed in the schematic in [Figure 3](#) and [Figure 4](#) on page 10.

Schematics

This section provides schematics for the Z8 Encore! XP[®] F042A Series Development Board.

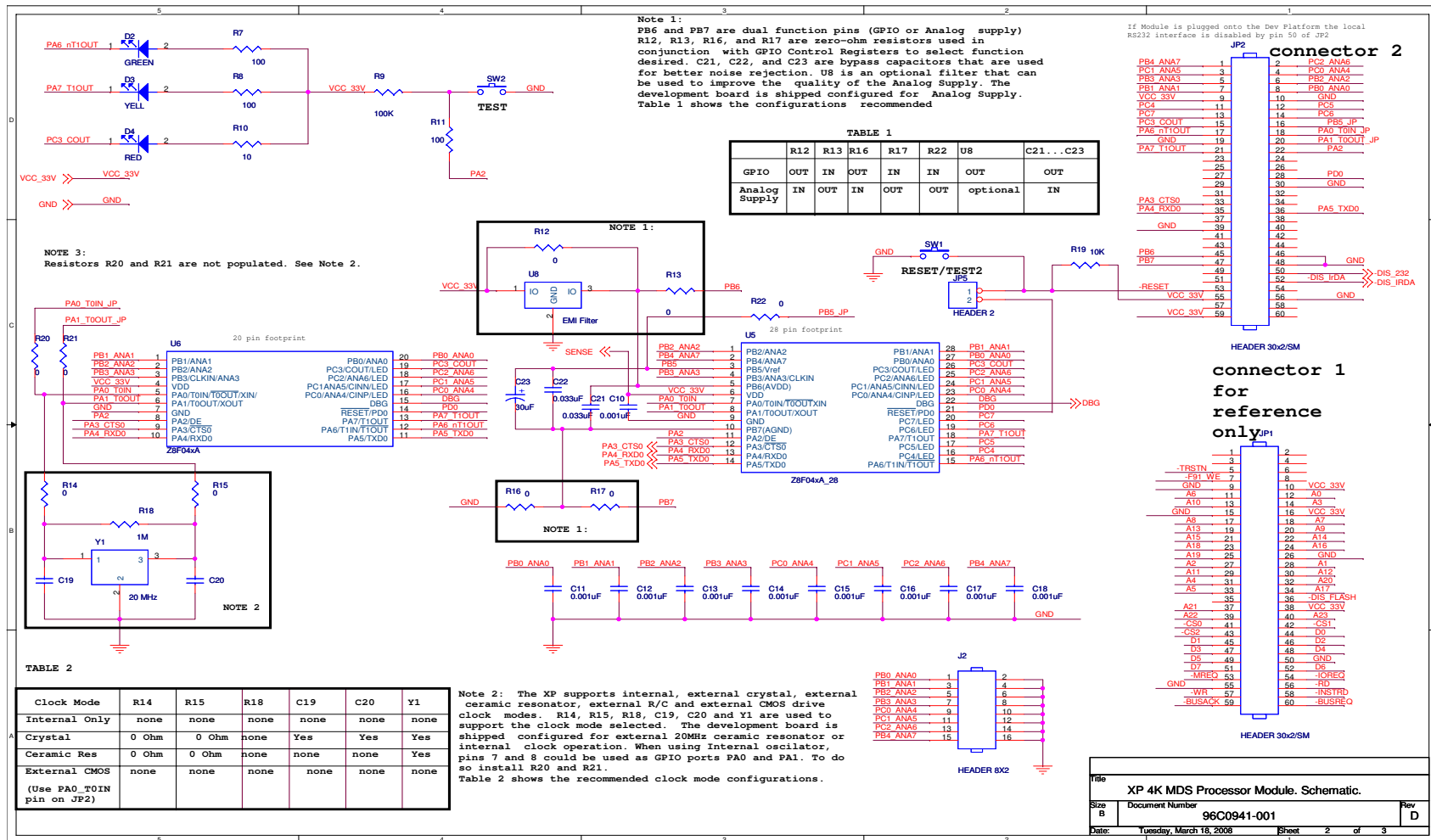

Figure 3. Schematic, Z8 Encore! XP F042A Series MCU Development Board, Page 1 of 2

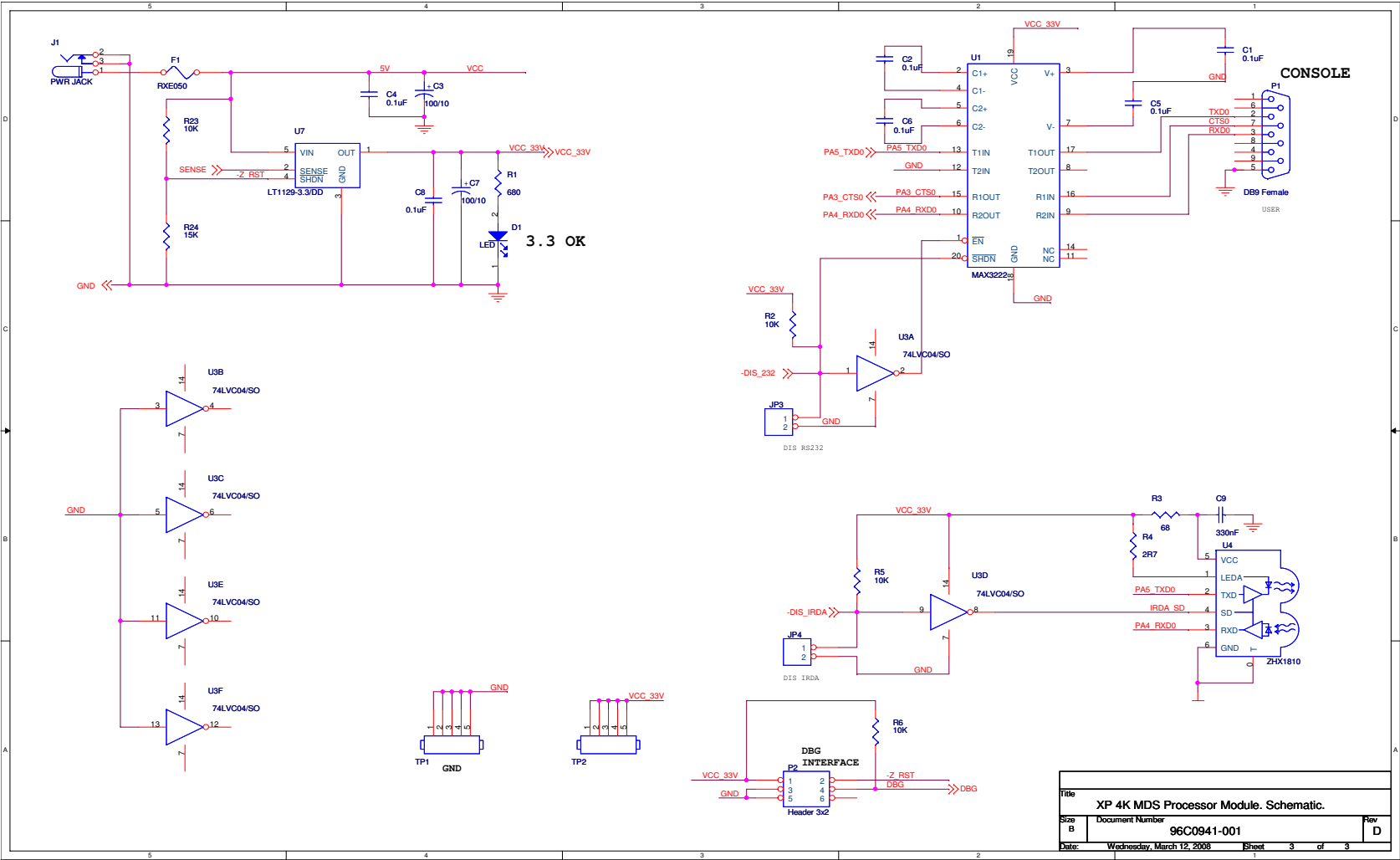

Figure 4. Schematic, Z8 Encore! XP F042A Series MCU Development Board, Page 2 of 2



Customer Support

For answers to technical questions about the product, documentation, or any other issues with Zilog's offerings, please visit Zilog's Knowledge Base at:

<http://www.zilog.com/kb>.

For any comments, detail technical questions, or reporting problems, please visit Zilog's Technical Support at:

<http://support.zilog.com>.



Warning: DO NOT USE IN LIFE SUPPORT

LIFE SUPPORT POLICY

ZILOG'S PRODUCTS ARE NOT AUTHORIZED FOR USE AS CRITICAL COMPONENTS IN LIFE SUPPORT DEVICES OR SYSTEMS WITHOUT THE EXPRESS PRIOR WRITTEN APPROVAL OF THE PRESIDENT AND GENERAL COUNSEL OF ZILOG CORPORATION.

As used herein

Life support devices or systems are devices which (a) are intended for surgical implant into the body, or (b) support or sustain life and whose failure to perform when properly used in accordance with instructions for use provided in the labeling can be reasonably expected to result in a significant injury to the user. A critical component is any component in a life support device or system whose failure to perform can be reasonably expected to cause the failure of the life support device or system or to affect its safety or effectiveness.

Document Disclaimer

©2008 by Zilog, Inc. All rights reserved. Information in this publication concerning the devices, applications, or technology described is intended to suggest possible uses and may be superseded. ZILOG, INC. DOES NOT ASSUME LIABILITY FOR OR PROVIDE A REPRESENTATION OF ACCURACY OF THE INFORMATION, DEVICES, OR TECHNOLOGY DESCRIBED IN THIS DOCUMENT. ZILOG ALSO DOES NOT ASSUME LIABILITY FOR INTELLECTUAL PROPERTY INFRINGEMENT RELATED IN ANY MANNER TO USE OF INFORMATION, DEVICES, OR TECHNOLOGY DESCRIBED HEREIN OR OTHERWISE. The information contained within this document has been verified according to the general principles of electrical and mechanical engineering.

Z8, Z8 Encore!, and Z8 Encore! XP are registered trademarks of Zilog, Inc. eZ8 is a trademark of Zilog, Inc. All other product or service names are the property of their respective owners.