

Fast CMOS 3.3V 16-Bit Bidirectional Transceiver
Product Features

- Compatible with LCX™ and LVT™ families of products
- Supports 5V Tolerant Mixed Signal Mode Operation
 - Input can be 3V or 5V
 - Output can be 3V or connected to 5V bus
- Advanced Low Power CMOS Operation
- Excellent output drive capability:
Balanced drives (24 mA sink and source)
- Pin compatible with industry standard double-density pinouts
- Low ground bounce outputs
- Hysteresis on all inputs
- Industrial operating temperature range: -40°C to +85°C
- Multiple center pins and distributed Vcc/GND pins minimize switching noise
- Packaging (Pb-free & Green available):
 - 48-pin 240 mil wide thin plastic TSSOP (A)
 - 48-pin 300 mil wide plastic SSOP (V)

Product Description

The PI74LPT16245 is a 16-bit bidirectional transceiver designed for asynchronous two-way communication between data buses. The direction control input pin (xDIR) determines the direction of data flow through the bidirectional transceiver. The Direction and Output Enable controls are designed to operate this device as either two independent 8-bit transceivers or one 16-bit transceiver. The output enable (OE) input, when HIGH, disables both A and B ports by placing them in HIGH Z condition.

The PI74LPT16245 can be driven from either 3.3V or 5.0V devices allowing this device to be used as a translator in a mixed 3.3/5.0V system.

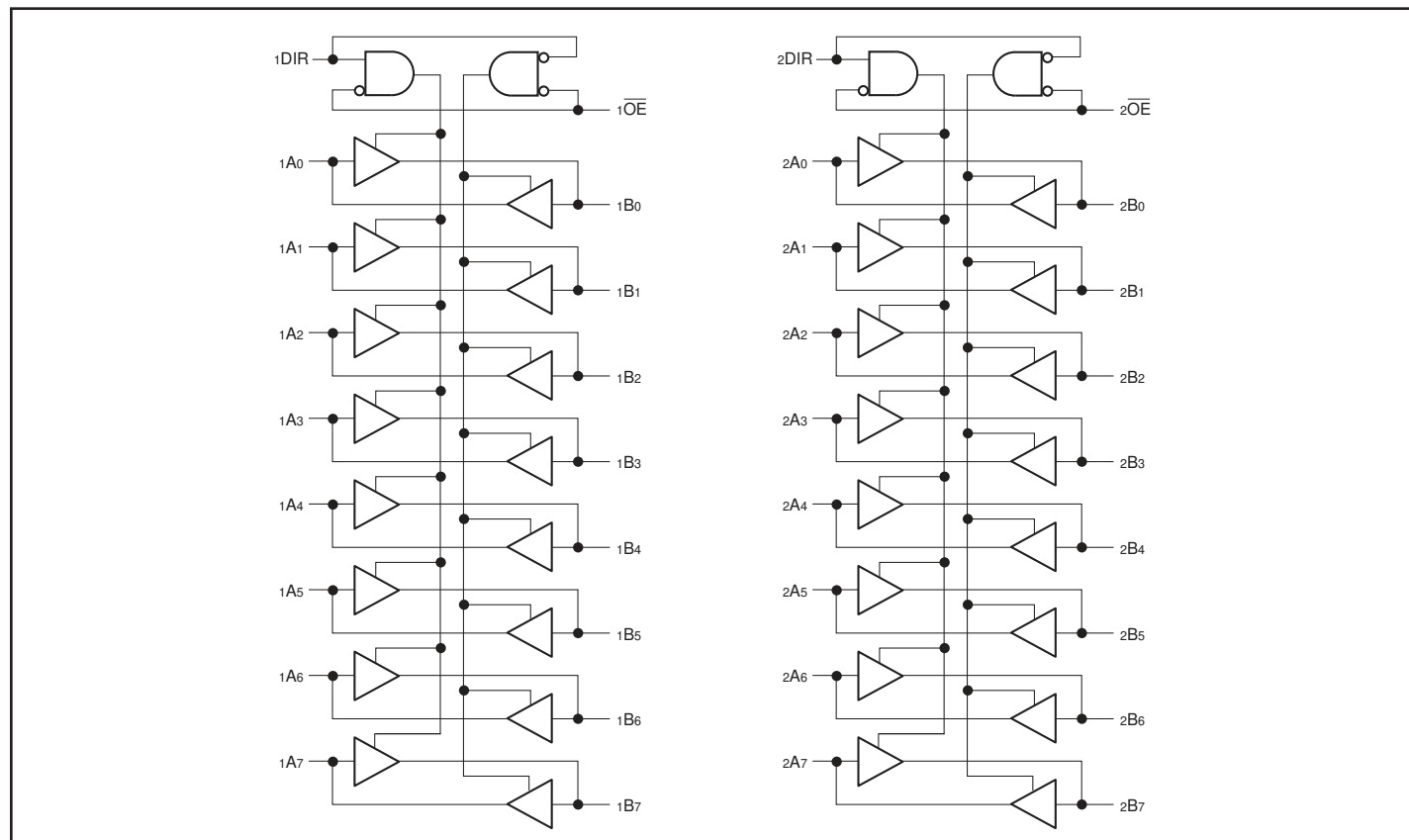
Logic Block Diagram

Maximum Ratings

(Above which the useful life may be impaired. For user guidelines, not tested.)

Storage Temperature	-55°C to +125°C
Ambient Temperature with Power Applied	-40°C to +85°C
Supply Voltage to Ground Potential (Inputs & Vcc Only)	-0.5V to +7.0V
Supply Voltage to Ground Potential (Outputs & D/O Only) ...	-0.5V to +7.0V
DC Input Voltage	-0.5V to +7.0V
DC Output Current.....	120 mA
Power Dissipation	1.0W

Note:

Stresses greater than those listed under MAXIMUM RATINGS may cause permanent damage to the device. This is a stress rating only and functional operation of the device at these or any other conditions above those indicated in the operational sections of this specification is not implied. Exposure to absolute maximum rating conditions for extended periods may affect reliability.

Product Pin Configuration

<p>1DIR □ 1</p> <p>1B0 □ 2</p> <p>1B1 □ 3</p> <p>GND □ 4</p> <p>1B2 □ 5</p> <p>1B3 □ 6</p> <p>Vcc □ 7</p> <p>1B4 □ 8</p> <p>1B5 □ 9</p> <p>GND □ 10</p> <p>1B6 □ 11</p> <p>1B7 □ 12</p> <p>2B0 □ 13</p> <p>2B1 □ 14</p> <p>GND □ 15</p> <p>2B2 □ 16</p> <p>2B3 □ 17</p> <p>Vcc □ 18</p> <p>2B4 □ 19</p> <p>2B5 □ 20</p> <p>GND □ 21</p> <p>2B6 □ 22</p> <p>2B7 □ 23</p> <p>2DIR □ 24</p>	<p>48 □ 1OE</p> <p>47 □ 1A0</p> <p>46 □ 1A1</p> <p>45 □ GND</p> <p>44 □ 1A2</p> <p>43 □ 1A3</p> <p>42 □ Vcc</p> <p>41 □ 1A4</p> <p>40 □ 1A5</p> <p>39 □ GND</p> <p>38 □ 1A6</p> <p>37 □ 1A7</p> <p>36 □ 2A0</p> <p>35 □ 2A1</p> <p>34 □ GND</p> <p>33 □ 2A2</p> <p>32 □ 2A3</p> <p>31 □ Vcc</p> <p>30 □ 2A4</p> <p>29 □ 2A5</p> <p>28 □ GND</p> <p>27 □ 2A6</p> <p>26 □ 2A7</p> <p>25 □ 2OE</p>
--	---

Truth Table⁽¹⁾

Inputs		Outputs
xOE	xDIR	
L	L	Bus B Data to Bus A
L	H	Bus A Data to Bus B
H	X	Z

Notes:

1. H = High Voltage Level, X = Don't Care,
L = Low Voltage Level, Z = High Impedance

Product Pin Description

Pin Name	Description
xOE	3-State Output Enable Inputs (Active LOW)
xDIR	Direction Control Input
xAx	Side A Inputs or 3-State Inputs
xYx	Side B Outputs or 3-State Outputs
GND	Ground
VCC	Power

Capacitance ($T_A = 25^\circ\text{C}$, $f = 1\text{ MHz}$)

Parameters ⁽¹⁾	Description	Test Conditions	Typ	Max.	Units
C_{IN}	Input Capacitance	$V_{IN} = 0V$	4.5	6	pF
C_{OUT}	Output Capacitance	$V_{OUT} = 0V$	5.5	8	

Notes:

1. This parameter is determined by device characterization but is not production tested.

DC Electrical Characteristics (Over the Operating Range, $T_A = -40^\circ\text{C}$ to $+85^\circ\text{C}$, $V_{CC} = 2.7V$ to $3.6V$)

Parameters	Description	Test Conditions ⁽¹⁾		Min.	Typ ⁽²⁾	Max.	Units
V_{IH}	Input HIGH Voltage (Input pins)	Guaranteed Logic HIGH Level		2.2		5.5	V
	Input HIGH Voltage (I/O pins)			2.0		5.5	
V_{IL}	Input LOW Voltage (Input and I/O pins)	Guaranteed Logic LOW Level		-0.5		0.8	
I_{IH}	Input HIGH Current (Input pins)	$V_{CC} = \text{Max.}$	$V_{IN} = 5.5V$			± 1	μA
	Input HIGH Current (I/O pins)	$V_{CC} = \text{Max.}$	$V_{IN} = V_{CC}$			± 1	
I_{IL}	Input LOW Current (Input pins)	$V_{CC} = \text{Max.}$	$V_{IN} = \text{GND}$			± 1	μA
	Input LOW Current (I/O pins)	$V_{CC} = \text{Max.}$	$V_{IN} = \text{GND}$			± 1	
I_{OZH}	High Impedance Output Current	$V_{CC} = \text{Max.}$	$V_{OUT} = 5.5V$			± 1	μA
I_{OZL}	(3-State Output pins)	$V_{CC} = \text{Max.}$	$V_{OUT} = \text{GND}$			± 1	
V_{IK}	Clamp Diode Voltage	$V_{CC} = \text{Min.}, I_{IN} = -18\text{ mA}$			-0.7	-1.2	V
I_{OHD}	Output HIGH Current	$V_{CC} = 3.3V, V_{IN} = V_{IL}$ or $V_{IL}, V_O = 1.5V^{(3)}$		-36	-60	-110	mA
I_{ODL}	Output LOW Current	$V_{CC} = 3.3V, V_{IN} = V_{IH}$ or $V_{IL}, V_O = 1.5V^{(3)}$		50	90	200	
V_{OH}	Output HIGH Voltage	$V_{CC} = \text{Min.}$	$I_{OH} = -0.1\text{ mA}$	$V_{CC} - 0.2$			V
		$V_{IN} = V_{IH}$ or V_{IL}	$I_{OH} = -3\text{ mA}$	2.4	3.0		
		$V_{CC} = 3.0V,$	$I_{OH} = -8\text{ mA}$	2.4 ⁽⁵⁾	3.0		
		$V_{IN} = V_{IH}$ or V_{IL}	$I_{OH} = -24\text{ mA}$	2.0			
V_{OL}	Output LOW Voltage	$V_{CC} = \text{Min.}$ $V_{IN} = V_{IH}$ or V_{IL}	$I_{OL} = 0.1\text{ mA}$			0.2	
			$I_{OL} = 16\text{ mA}$		0.2	0.4	
			$I_{OL} = 24\text{ mA}$		0.3	0.5	
I_{OS}	Short Circuit Current ⁽⁴⁾	$V_{CC} = \text{Max.}^{(3)}, V_{OUT} = \text{GND} - 60$		-60	-85	-240	mA
I_{OFF}	Power Down Disable	$V_{CC} = 0V, V_{IN}$ or $V_{OUT} \leq 4.5V$				± 100	μA
V_H	Input Hysteresis				150		mV

Notes:

1. For Max. or Min. conditions, use appropriate value specified under Electrical Characteristics for the applicable device type.
2. Typical values are at $V_{CC} = 3.3V$, $+25^\circ\text{C}$ ambient and maximum loading.
3. Not more than one output should be shorted at one time. Duration of the test should not exceed one second.
4. This parameter is guaranteed but not tested.
5. $V_{OH} = V_{CC} - 0.6V$ at rated current.

Power Supply Characteristics

Parameters	Description	Test Conditions ⁽¹⁾		Min.	Typ ⁽²⁾	Max.	Units
I _{CC}	Quiescent Power Supply Current	V _{CC} = Max.	V _{IN} = GND or V _{CC}		0.1	10	μA
ΔI _{CC}	Quiescent Power Supply Current TTL Inputs HIGH	V _{CC} = Max.	V _{IN} = V _{CC} - 0.6V ⁽³⁾			500	
I _{CCD}	Dynamic Power Supply ⁽⁴⁾	V _{CC} = Max., Outputs Open x \overline{OE} = GND One Bit Toggling 50% Duty Cycle	V _{IN} = V _{CC} V _{IN} = GND		50	75	μA/ MHz
I _C	Total Power Supply Current ⁽⁶⁾	V _{CC} = Max., Outputs Open f _i = 10 MHz 50% Duty Cycle x \overline{OE} = GND One Bit Toggling	V _{IN} = V _{CC} - 0.6V V _{IN} = GND		0.5	0.8	mA
		V _{CC} = Max., Outputs Open f _i = 2.5 MHz 50% Duty Cycle x \overline{OE} = GND 16 Bits Toggling	V _{IN} = V _{CC} - 0.6V V _{IN} = GND		2.0	3.3 ⁽⁵⁾	

Notes:

- For Max. or Min. conditions, use appropriate value specified under Electrical Characteristics for the applicable device.
- Typical values are at V_{CC} = 3.3V, +25°C ambient.
- Per TTL driven input; all other inputs at V_{CC} or GND.
- This parameter is not directly testable, but is derived for use in Total Power Supply Calculations.
- Values for these conditions are examples of the I_{CC} formula. These limits are guaranteed but not tested.
- I_C = I_{QUIESCENT} + I_{INPUTS} + I_{DYNAMIC}
 $I_C = I_{CC} + \Delta I_{CC} D_H N_T + I_{CCD} (f_{CP}/2 + f_i N_i)$
 I_{CC} = Quiescent Current (I_{CC1}, I_{CC2} and I_{CC3})
 ΔI_{CC} = Power Supply Current for a TTL High Input
 D_H = Duty Cycle for TTL Inputs High
 N_T = Number of TTL Inputs at D_H
 I_{CCD} = Dynamic Current Caused by an Input Transition Pair (HLH or LHL)
 f_{CP} = Clock Frequency for Register Devices (Zero for Non-Register Devices)
 N_{CP} = Number of Clock Inputs at f_{CP}
 f_i = Input Frequency
 N_i = Number of Inputs at f_i
 All currents are in milliamps and all frequencies are in megahertz.

Switching Characteristics over Operating Range⁽¹⁾

Parameters	Description	Conditions ⁽²⁾	LPT16245		LPT16245A		LPT16245C		Units
			Com.		Com.		Com.		
			Min ⁽³⁾	Max.	Min ⁽³⁾	Max.	Min ⁽³⁾	Max.	
t _{PLH} t _{PHL}	Propagation Delay xAX to xBx	C _L = 50pF R _L = 500Ω	1.5	5.2	1.5	4.6	1.5	4.1	ns
t _{PZH} t _{PZL}	Output Enable Time xOE to xBx		1.5	7.2	1.5	6.2	1.5	5.8	
t _{PHZ} t _{PLZ}	Output Disable Time ⁽⁴⁾ xOE to xBx		1.5	7.2	1.5	5.0	1.5	4.8	
t _{PZH} t _{PZL}	Output Enable Time xDIR to A or B		1.5	7.2	1.5	6.2	1.5	5.8	
t _{PHZ} t _{PLZ}	Output Disable Time xDIR to A or B ⁽⁴⁾		1.5	7.2	1.5	5.0	1.5	4.8	
t _{SK(o)}	Output Skew ⁽⁵⁾			0.5		0.5		0.5	

Notes:

1. Propagation Delays and Enable/Disable times are with V_{cc} = 3.3V ±0.3V, normal range. For V_{cc} = 2.7V, extended range, all Propagation Delays and Enable/Disable times should be degraded by 20%.
2. See test circuit and wave forms.
3. Minimum limits are guaranteed but not tested on Propagation Delays.
4. This parameter is guaranteed but not production tested.
5. Skew between any two outputs, of the same package, switching in the same direction. This parameter is guaranteed by design.

DOCUMENT CONTROL NO.
PD - 1501

REVISION: G
DATE: 03/09/05

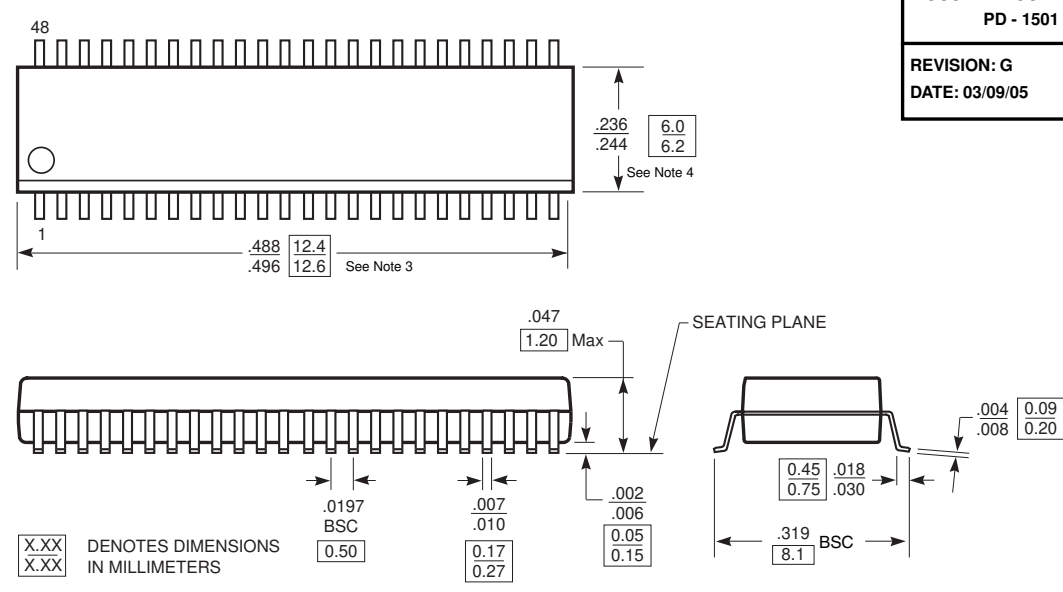

X.XX DENOTES DIMENSIONS
X.XX IN MILLIMETERS



Pericom Semiconductor Corporation
 3545 N. 1st Street, San Jose, CA 95134
 1-800-435-2335 • www.pericom.com

DESCRIPTION: 48-Pin 240-Mil Wide TSSOP

PACKAGE CODE: A

Note:

1. Controlling dimensions in millimeters.
2. Ref: JEDEC MO-153F/ED
3. Dimension does not include mold flash, protrusions or gate burrs. Mold flash, protrusions and gate burrs shall not exceed 0.15mm per side.
4. Dimension does not include interlead flash or protrusion. Interlead flash or protrusion shall not exceed 0.25mm per side.

DOCUMENT CONTROL NO.
PD - 1401

REVISION: E
DATE: 03/09/05

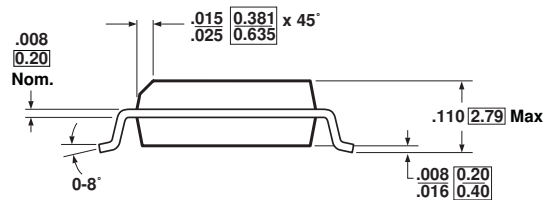
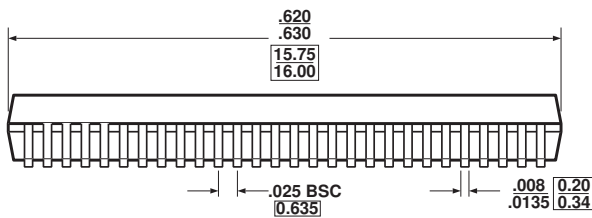
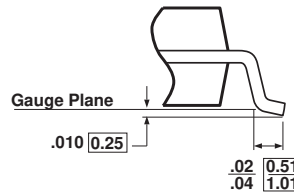
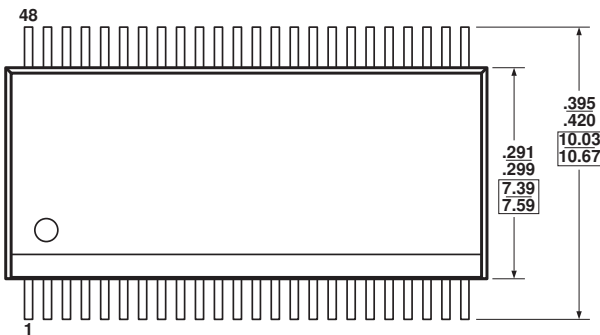

X.XX DENOTES DIMENSIONS
X.XX IN MILLIMETERS

Notes:
1) Controlling dimensions in inches.
2) Ref: JEDEC MO-118B/AA



Pericom Semiconductor Corporation
3545 N. 1st Street, San Jose, CA 95134
1-800-435-2335 • www.pericom.com

DESCRIPTION: 48-Pin, 300-Mil Wide, SSOP

PACKAGE CODE: V

Ordering Information

Ordering Code	Package Code	Description
PI74LPT16245AE	A	Pb-free & Green, 48-pin 173 mil wide plastic TSSOP
PI74LPT16245AAE	A	Pb-free & Green, 48-pin 173 mil wide plastic TSSOP
PI74LPT16245VE	V	Pb-free & Green, 48-pin 300 mil wide plastic SSOP
PI74LPT16245CAE	A	Pb-free & Green, 48-pin 173 mil wide plastic TSSOP

Notes:

- Thermal characteristics can be found on the company web site at www.pericom.com/packaging/
- E = Pb-free & Green
- Adding an X suffix = Tape/Reel