



DOCUMENT NUMBER AND REVISION  
**VL-FS-COG-VLGT6566-04 REV. B**  
**(COG-VLGT6566-04)**

DOCUMENT TITLE:  
**SPECIFICATION**  
**OF**  
**LCD MODULE TYPE**

CUSTOMER	VLE
MODEL NUMBER	COG-VLGT6566-04
CUSTOMER APPROVAL	
DATE	

DEPARTMENT	NAME	SIGNATURE	DATE
PREPARED BY	ZENG LI	<i>Zeng Li</i>	2010.10.28
CHECKED BY	HUANG YUAN LIANG	<i>hyl</i>	2010.10.28
APPROVED BY	ICE CHEN	<i>Ice Chen</i>	2010.10.28
QUALITY BY	MICHAEL HUI	<i>Michael Hui</i>	

DISTRIBUTION LIST: MARKETING



**VARITRONIX**

VL-FS-COG-VLGT6566-04 REV.B

(COG-VLGT6566-04)

OCT/2010

PAGE 2 OF 18

**DOCUMENT REVISION HISTORY**

DOCUMENT REVISION FROM TO	DATE	DESCRIPTION	CHANGED BY	CHECKED BY
A	2010.06.28	First Release.	ZENG LI	HUANG YUAN LIANG
B	2010.10.28	Items 1 was updated: 1.) (Page 1) Customer name was updated.	ZENG LI	HUANG YUAN LIANG



## CONTENTS

	<u>Page No.</u>
1. GENERAL DESCRIPTION	4
2. MECHANICAL SPECIFICATIONS	4
3. INTERFACE SIGNALS	8
4. ABSOLUTE MAXIMUM RATINGS	9
4.1 ELECTRICAL MAXIMUM RATINGS - FOR IC ONLY	9
4.2 ENVIRONMENTAL CONDITION	9
5. ELECTRICAL SPECIFICATIONS	10
5.1 TYPICAL ELECTRICAL CHARACTERISTICS	10
5.2 TIMING SPECIFICATION	11
5.3 POWER ON/OFF SEQUENCE	13
6. OPTICAL CHARACTERISTICS (FOR TFT PANEL ONLY)	14
7. TFT PANEL INSPECTION SPECIFICATIONS	16
8. REMARK	18

**VARITRONIX LIMITED**

**Specification  
 of  
 LCD Module Type  
 Model No.: COG-VLGT6566-04**

**1. General Description**

- 4.3" TFT, 480 x RGB x 272 dots, 16M Colors, positive, transmissive dot matrix LCD module.
- Viewing angle: 6 o'clock.
- Driving IC: 'HIMAX' HX8257-A (COG) TFT LCD controller & driver or equivalent.
- Data interface: parallel RGB interface.
- Logic voltage: 3.0V.
- White LED backlight.
- FPC connection.
- "RoHS" compliance.

**2. Mechanical Specifications**

The mechanical detail is shown in Fig. 1 and summarized in Table 1 below.

Table 1

Parameter	Specifications	Unit
Outline dimensions	105.5(W) x 109.8(H) x 3.05(D)	mm
Color TFT 480xRGBx272	Active area	95.04(W) x 53.86(H)
	Display format	480 x RGB x 272
	Color configuration	RGB stripe
	Dot pitch	0.198(RGB)(W) x 0.198(H) (0.066(W) x 0.198(H))
Weight	Approx: 45	gram



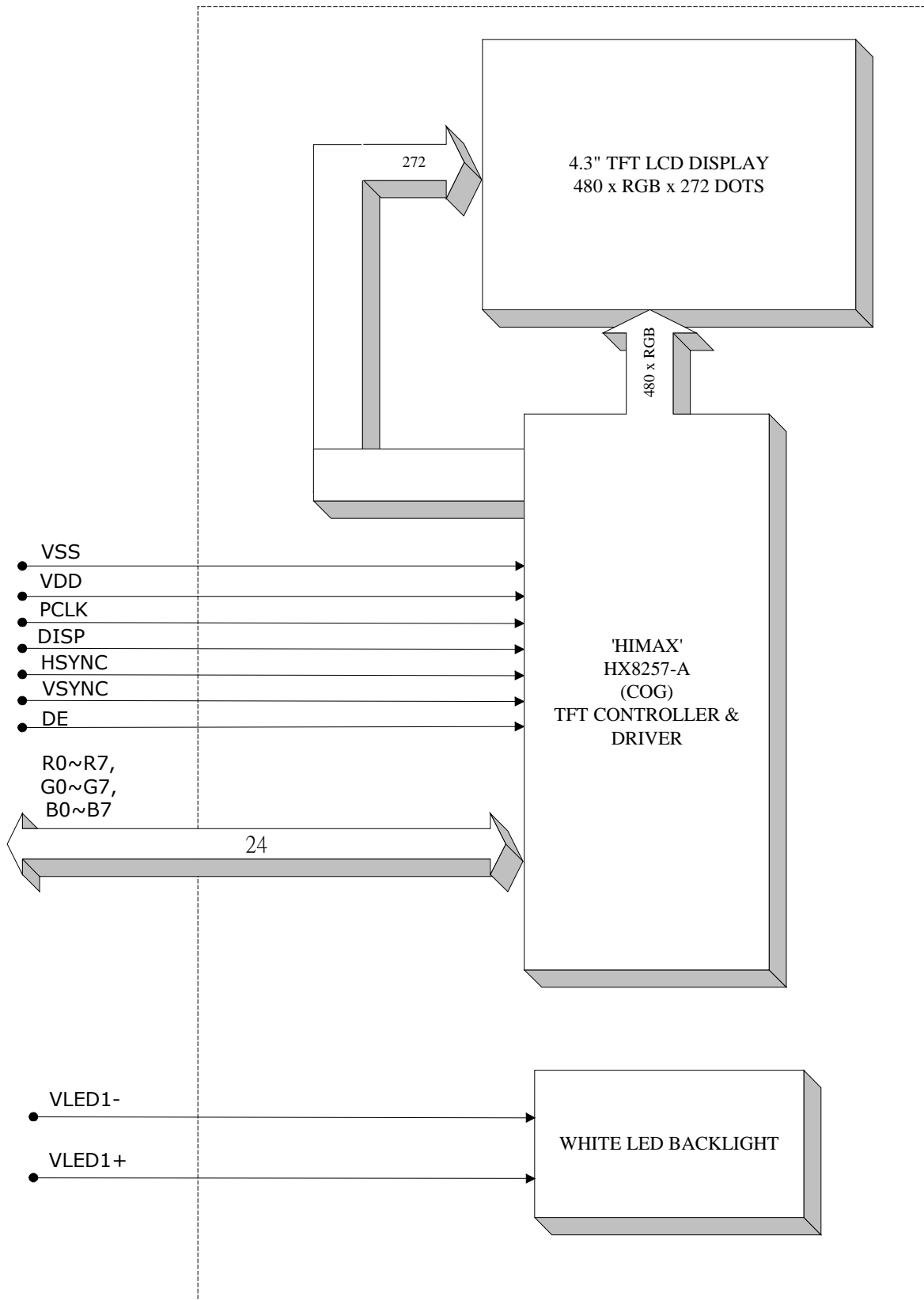

Figure 2: Block diagram

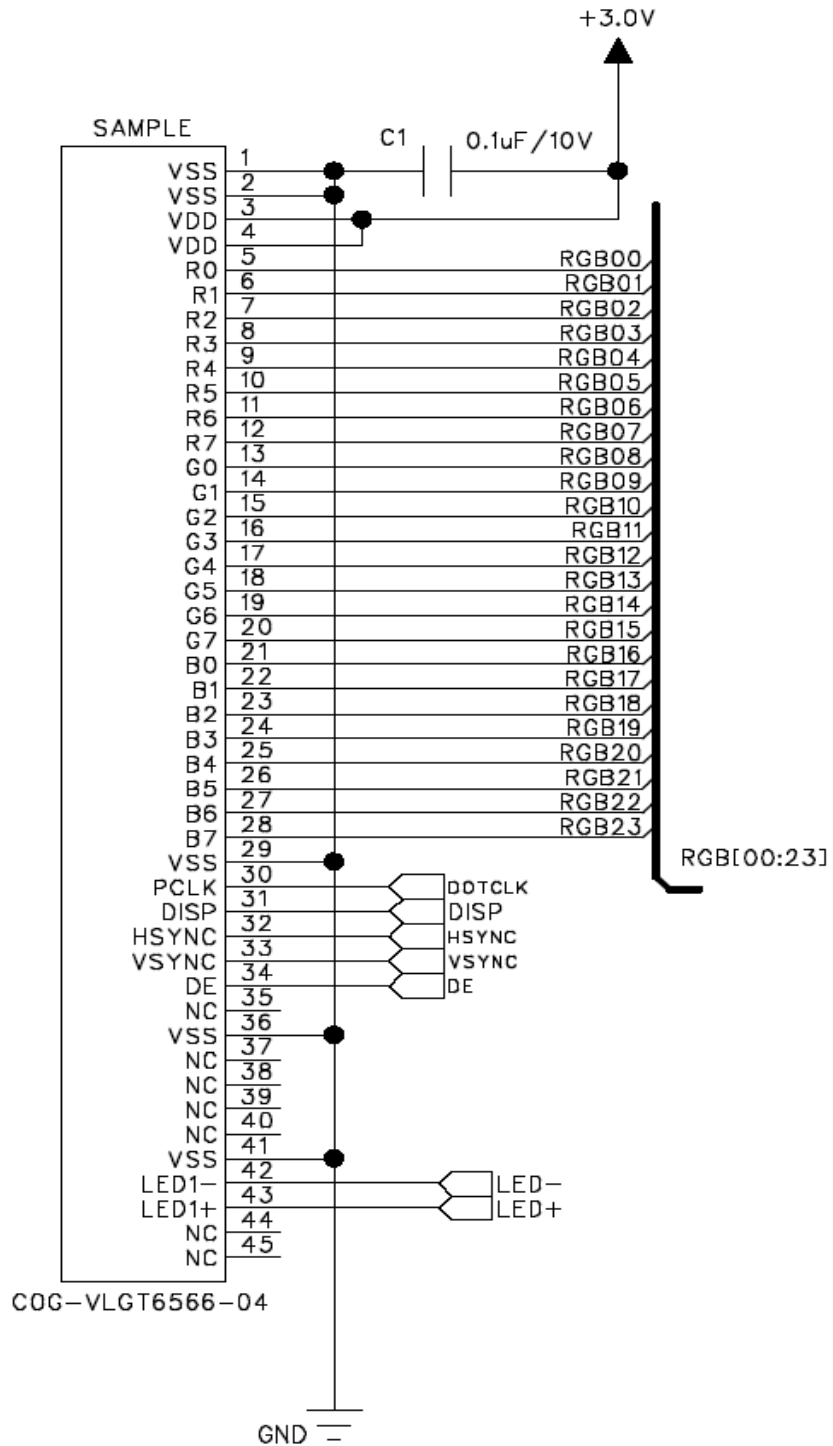

Figure 3: Reference circuit diagram

### 3. Interface signals

Table 2(a): Pin assignment

Pin No.	Symbol	Description
1~2	VSS	Ground.
3~4	VDD (VDDIO, VCI)	Power supply.
5	R0	Digital data input. R7~R0/G7~G0/B7~B0 are used.
6	R1	
7	R2	
8	R3	
9	R4	
10	R5	
11	R6	
12	R7	
13	G0	
14	G1	
15	G2	
16	G3	
17	G4	
18	G5	
19	G6	
20	G7	
21	B0	
22	B1	
23	B2	
24	B3	
25	B4	
26	B5	
27	B6	
28	B7	
29	VSS	Ground.
30	PCLK (CLK/DOTCLK)	Clock signal for data latching in RGB interface.
31	PON (DISP)	Display on/off mode control. Internally pulled high. (a) DISP=L, standby mode. (b) DISP=H, normal display mode.
32	HSYNC (HS)	Horizontal sync input in RGB interface.
33	VSYNC (VS)	Vertical sync input in RGB interface.
34	DE	Input data enable control in RGB interface.
35	NC	No connection.



Table 2(b): Pin assignment

Pin No.	Symbol	Description
36	VSS	Ground.
37	NC	No connection.
38	NC	
39	NC	
40	NC	
41	VSS	Ground.
42	VLED1-	Cathode of LED backlight.
43	VLED1+	Anode of LED backlight.
44~45	NC	No connection.

#### 4. Absolute Maximum Ratings

##### 4.1 Electrical Maximum Ratings – for IC Only

Table 3

Parameter	Symbol	Min.	Max.	Unit
Logic Power Supply	VDD - VSS	-0.3	+4.0	V

Note: The modules may be destroyed if they are used beyond the absolute maximum ratings.

All voltage values are referenced to VSS = 0V.

##### 4.2 Environmental Condition

Table 4

Item	Operating temperature (Topr)		Storage temperature (Tstg) (Note 1)		Remark
	Min.	Max.	Min.	Max.	
Ambient temperature (Ta)	-20°C	+70°C	-30°C	+80°C	Dry
Humidity (note 1)	90% max. RH for Ta ≤ 40°C < 50% RH for 40°C < Ta ≤ Maximum operating temperature				No condensation
Vibration (IEC 68-2-6) cells must be mounted on a suitable connector	Frequency: 10 ~ 55 Hz Amplitude: 0.75 mm Duration: 20 cycles in each direction.				3 directions
Shock (IEC 68-2-27) Half-sine pulse shape	Pulse duration: 11 ms Peak acceleration: 981 m/s <sup>2</sup> = 100g Number of shocks: 3 shocks in 3 mutually perpendicular axes.				3 directions

Note 1: Product cannot sustain at extreme storage conditions for long time.

## 5. Electrical Specifications

### 5.1 Typical Electrical Characteristics

At Ta = 25 °C, VDD=3.0±0.1V, VSS=0V.

Table 5

Parameter	Symbol	Conditions	Min.	Typ.	Max.	Unit
Power supply voltage (Logic)	VDD		2.9	3.0	3.1	V
Input signal voltage	V <sub>IH</sub>	“H” level	0.8VDD	-	VDD	V
	V <sub>IL</sub>	“L” level	0	-	0.2VDD	V
Supply current (Logic)	IDD	VDD=3.0V	-	-	30	mA
Supply voltage of white LED backlight	VLED	Forward current =20 mA @25°C	-	23.1	-	V
Luminance (on the backlight surface)		No. of LED dies = 7 x 1 = 7 dies	2800	-	-	cd/m <sup>2</sup>

Note: Do not display the fixed pattern for a long time because it may develop image sticking due to the LCD structure. It should change pattern frequently. If the screen is displayed with fixed pattern, use a screen saver.



### 5.2.3 Input Setup Timing Requirement Characteristics

At  $T_a = 25\text{ }^\circ\text{C}$ ,  $V_{DD}=3.0\pm 0.1\text{V}$ ,  $V_{SS}=0\text{V}$ .

Table 8

Parameter	Symbol	Spec.			Unit
		Min.	Typ.	Max.	
DISP setup time	$t_{diss}$	10	-	-	ns
DISP hold time	$t_{dish}$	10	-	-	ns
Clock period	$PW_{CLK}^{(2)}$	66.7	-	-	ns
Clock pulse high period	$PWH^{(2)}$	26.7	-	-	ns
Clock pulse low period	$PWL^{(2)}$	26.7	-	-	ns
Hsync setup time	$t_{hs}$	10	-	-	ns
Hsync hold time	$t_{hh}$	10	-	-	ns
Data setup time	$t_{ds}$	10	-	-	ns
Data hold time	$t_{dh}$	10	-	-	ns
DE setup time	$t_{des}$	10	-	-	ns
DE hold time	$t_{deh}$	10	-	-	ns
Vsync setup time	$t_{vhs}$	10	-	-	ns
Vsync hold time	$t_{vhh}$	10	-	-	ns

Note: (1)  $t_r$ ,  $t_f$  is defined 10% to 90% of signal amplitude.

(2) For parallel interface, maximum clock frequency is 15MHz.

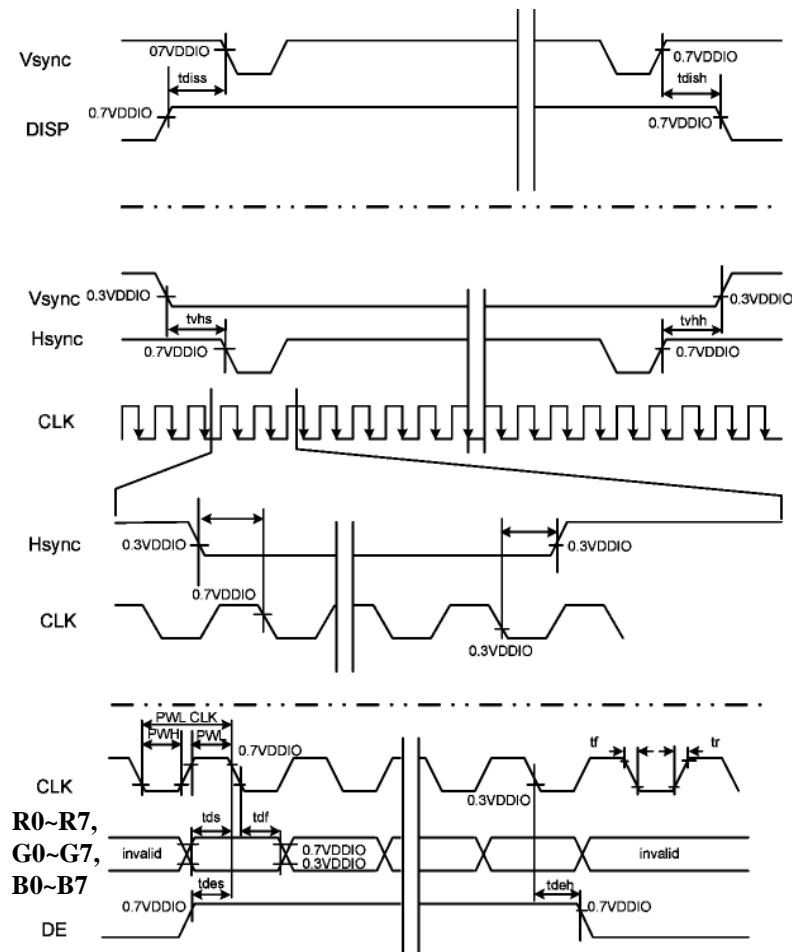

Figure 6: Input Setup Timing Requirement

### 5.3 Power On/Off Sequence

The HX8257-A has a power ON/OFF sequence control function. When DISP pin is pulled “H”, blank data is outputted for 10-frames first, from the falling edge of the following VSYNC signal. Similarly, when DISP is pulled “L”, 10-frames of blank data will be outputted from the falling edge of the following VSYNC, too. The blank data would be gray level 0 for normally black LC (NBW= “H”), and be gray level 255 for normally white LC (NBW= “L”).

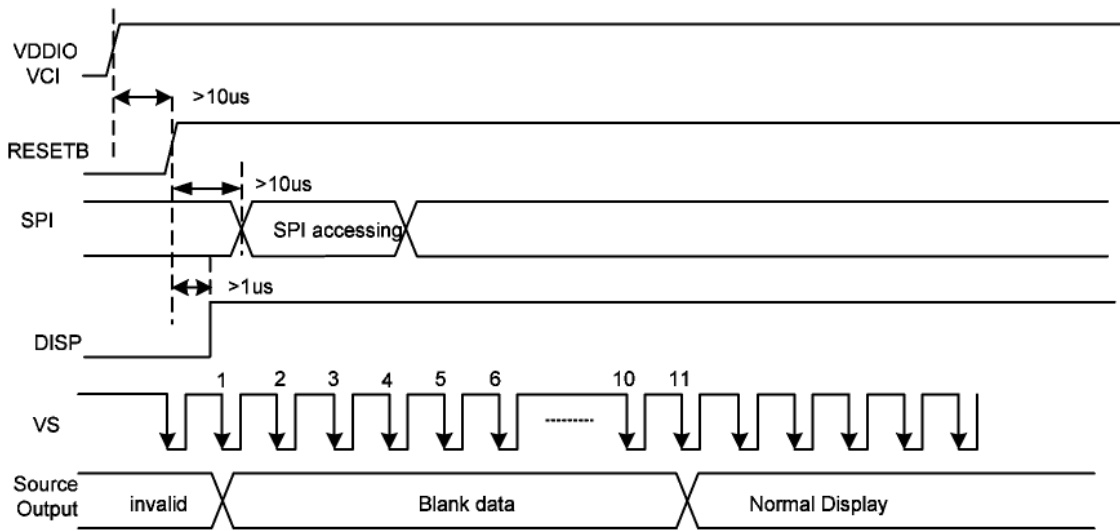

Figure 7: Power On Sequence

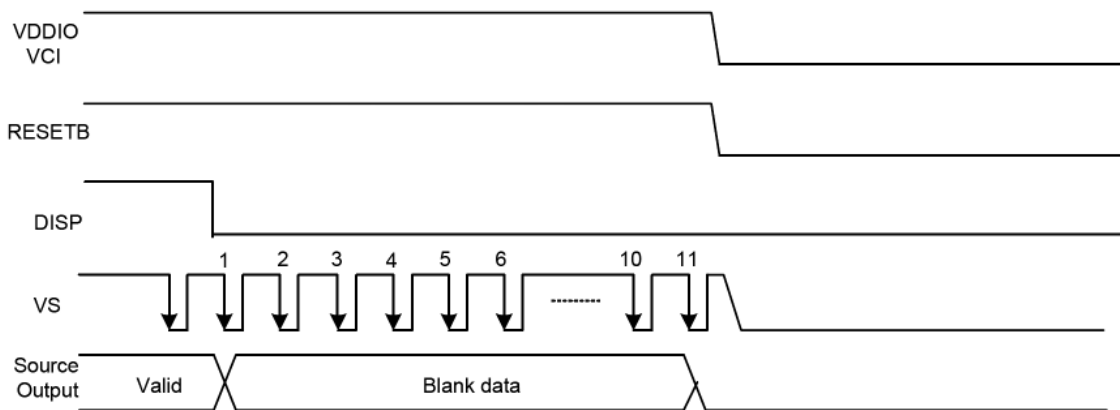

Figure 8: Power Off Sequence

**6. Optical Characteristics (for TFT panel only)**

**Table 9: Optical specifications (light source: C light)**

Items	Symbol	Condition	Specifications			Unit	Note
			Min.	Typ.	Max.		
Transmittance	T%		-	6.1	-	%	All left side data are based on following condition -- 6 o'clock NTSC: 50% LC: TN Light: C light (Machine:BM5A) Normal Polarizer Reference Only
Contrast Ratio	CR		-	250	-	-	
Response Time	T <sub>R</sub>		-	5	-	ms	
	T <sub>F</sub>		-	15	-	ms	
Chromaticity	Red	X <sub>R</sub>	0.590	0.620	0.650	-	
		Y <sub>R</sub>	0.314	0.344	0.374	-	
	Green	X <sub>G</sub>	0.276	0.306	0.336	-	
		Y <sub>G</sub>	0.533	0.563	0.593	-	
	Blue	X <sub>B</sub>	0.103	0.133	0.163	-	
		Y <sub>B</sub>	0.119	0.149	0.179	-	
	White	X <sub>W</sub>	0.281	0.311	0.341	-	
		Y <sub>W</sub>	0.319	0.349	0.379	-	
Viewing angle	Hor.	φ1(3 o'clock)	-	45	-	deg.	
		φ2(9 o'clock)	-	45	-		
	Ver.	θ2(12 o'clock)	-	15	-		
		θ1(6 o'clock)	-	35	-		

Note 1: Definition of Contrast Ratio (CR):

The contrast ratio can be calculated by the following expression.

$$\text{Contrast Ratio (CR)} = L63 / L0$$

L63: Luminance of gray level 63

L0: Luminance of gray level 0

$$\text{CR} = \text{CR} (5)$$

CR (X) is corresponding to the Contrast Ratio of the point X at Figure in Note 5.

Note 2: Definition of Response Time (TR, TF):

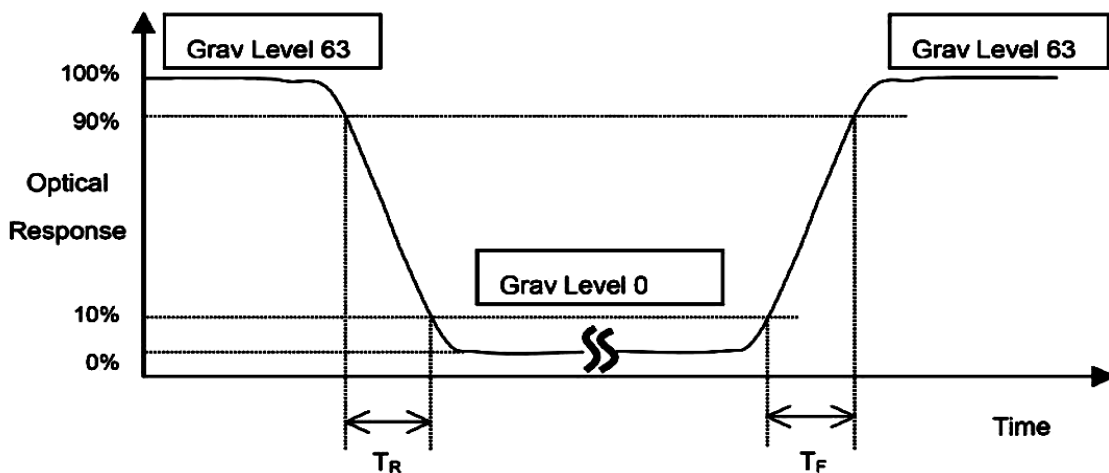

Figure 9

Note 3: Definition of view angle ( $\theta$ ,  $\phi$ ):

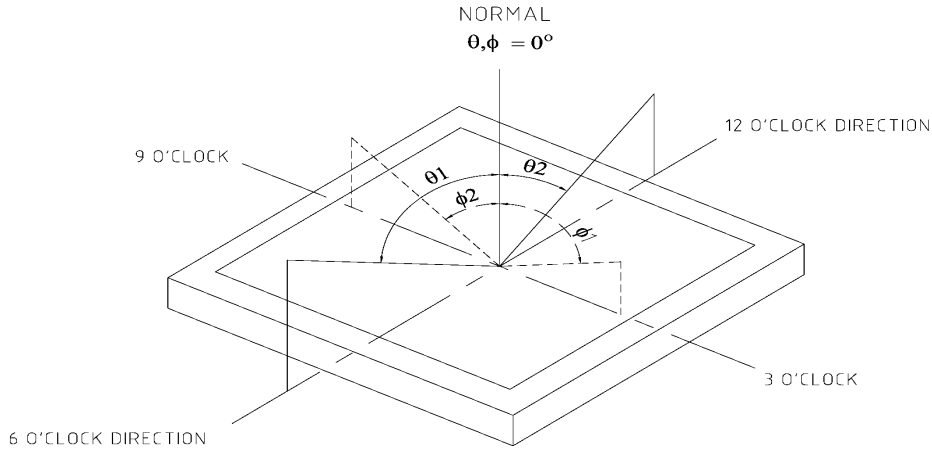

Figure 10

The above “Viewing Angle” is the measuring position with Largest Contrast Ratio; not for good image quality. View Direction for good image quality is 6 O’clock.

Note 4: Measurement Set-Up:

The LCD module should be stabilized at a given temperature for 20 minutes to avoid abrupt temperature change during measuring. In order to stabilize the luminance, the measurement should be executed after lighting Backlight for 20 minutes in a windless and dark room.

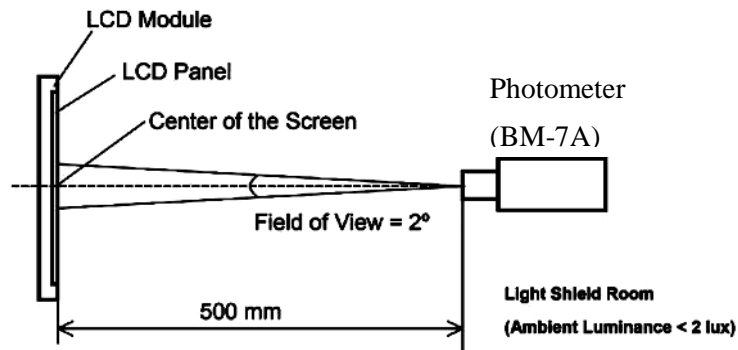

Figure 11

Note 5:

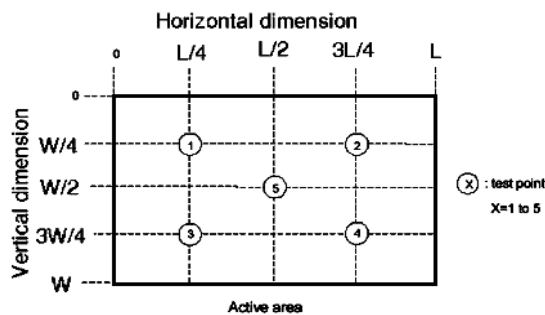
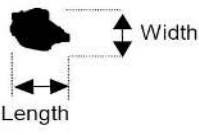
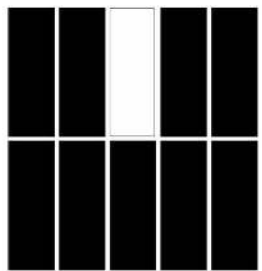
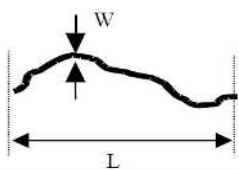
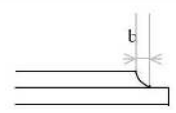
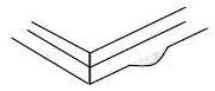
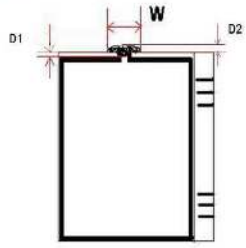
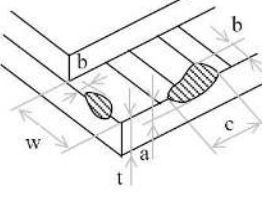
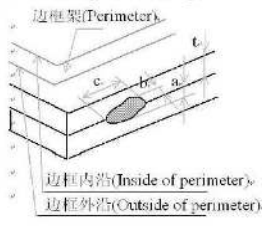
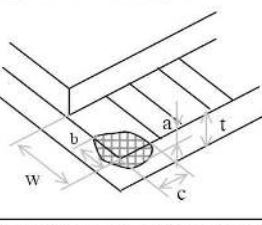



Figure 12

**7. TFT Panel Inspection Specifications**

Failure mode	Illustration	Category(Unit: mm)		Acceptable count	
				Viewing area	non-Viewing area
Black spot White spot	 $\Phi = (\text{Length} + \text{width}) / 2$	A	$\Phi \leq 0.10$	Not count	Not count
		B	$0.10 < \Phi \leq 0.15$	4, The gap between the two spots should be 5 mm and above. After divided the display into 9 zones with equal area, only 2 spots are acceptable in each zone.	
		C	$0.15 < \Phi \leq 0.25$	2	
		D	$0.25 < \Phi$	0	
Bright spot (Red spot, green spot and blue spot caused by damaged colour filter)		A	Area $\leq 1$ sub-pixel	2, The gap between the two spots should 5 mm and above.	N/A
Black line White line		A	$W \leq 0.05$	Not count	Not count
		B	$0.05 < W \leq 0.08, L \leq 8.0$	2	
		C	$0.08 < W$ or $L > 8.0$	Judged by spot spec	
Below are cosmetic inspection specifications					
Excess glass		$b \leq 1.0$ , this defect shall not affect the outline dimension or assembly process. (Remarks: For COG process, the defect size is decided by the dimension of LCD panel.)			
		This defect shall not affect the outline dimension or assembly process.			



<p>The depth of UV glue entered in LCD cell</p>		<p>a. <math>D1 \geq 0.2</math>, not enter into viewing area          b. <math>D2 \leq 0.8</math>,          c. <math>W = \text{End mouth width} + (2 \sim 6 \text{ mm})</math></p>	
<p>Glass defect (scratch, damage)</p>	<p>① LCD ledge damage</p> 	<p>Category</p>	
		<p>A</p>	<p>The defect shall not affect the outline dimension or assembly process at non ITO zone.</p>
		<p>B</p>	<p><math>b \leq 1/4w</math>, a &amp; c not count (at ITO zone)</p>
		<p>C</p>	<p>Alignment mark on LCD ledge shall not be damaged.</p>
	<p>② Outside of perimeter damage</p> <p>边框架(Perimeter)</p>  <p>边框内沿(Inside of perimeter)          边框外沿(outside of perimeter)</p>	<p>b can't reach inside of perimeter.</p>	
	<p>③ Joint glass damage</p> <p>边框架(Perimeter)</p>  <p>边框内沿(Inside of perimeter)          边框外沿(Outside of perimeter)</p>	<p>b can't reach outside of perimeter or ITO layout.</p>	
	<p>④ Corner damage</p> 	<p>A</p>	<p><math>a \leq t</math>, <math>b \leq 3.0</math>, <math>c \leq 3.0</math></p>
<p>Remark: A stands for thickness of damage, b for width, c for length and t for glass thickness. (Unit: mm)</p>		<p>B. Alignment mark on LCD ledge shall not be damaged.</p>	

## 8. Remark

### HANDLING LCD AND LCD MODULES

#### 1. Liquid Crystal Display (LCD)

LCD is made up of glass, organic sealant, organic fluid and polymer based polarizers. The following precautions should be taken when handling:

- (1) Keep the temperature within range for use and storage. Excessive temperature and humidity could cause polarization degradation, polarizer peel-off or bubble generation. When storage for a long period over 40° C is required, the relative humidity should be kept below 60%.
- (2) Do not contact the exposed polarizers with anything harder than an HB pencil lead. To clean dust off the display surface, wipe gently with cotton, chamois or other soft material soaked in petroleum benzin. Never scrub hard.
- (3) Varitronix does not responsible for any polarizer defect after the protective film has been removed from the display
- (4) Wipe off saliva or water drops immediately. Contact with water over a long period of time may cause polarizer deformation or color fading, while an active LCD with water condensation on its surface will cause corrosion of ITO electrodes.
- (5) PETROLEUM BENZIN is recommended to remove adhesives used to attach front/rear polarizers and reflectors, while chemicals like acetone, toluene, ethanol and isopropyl alcohol will cause damage to the polarizer. Avoid oil and fats. Avoid lacquer and epoxies which might contain solvents and hardeners to cause electrode erosion. Some solvents will also soften the epoxy covering the DIL pins and thereby weakening the adhesion of the epoxy on glass. This will cause the exposed electrodes to erode electrochemically when operating in high humidity and condensing environment.
- (6) Glass can be easily chipped or cracked from rough handling, especially at corners and edges.
- (7) Do not drive LCD with DC voltage.
- (8) When soldering DIL pins, avoid excessive heat and keep soldering temperature between 260°C to 300°C for no more than 5 seconds. Never use wave or reflow soldering.

#### 2. Liquid Crystal Display Modules (MDL)

##### 2.1 Mechanical Considerations

MDL's are assembled and adjusted with a high degree of precision. Avoid excessive shocks and do not make any alterations or modifications. The following should be noted.

- (1) Do not tamper in any way with the tabs on the metal frame.
- (2) Do not modify the PCB by drilling extra holes, changing its outline, moving its components or modifying its pattern.
- (3) Do not touch the elastomer connector (conductive rubber), especially when inserting an EL panel.

- (4) When mounting a MDL make sure that the PCB is not under any stress such as bending or twisting. Elastomer contacts are very delicate and missing pixels could result from slight dislocation of any of the elements.
- (5) Avoid pressing on the metal bezel, otherwise the elastomer connector could be deformed and lose contact, resulting in missing pixels.
- (6) If FPCA need to be bent, please refer the suggested bending area on the specification. The stiffener and component area on FPC/FPC/COF must not be bent during or after assembly (Note: for those models with FPC/FPC/COF+stiffener).
- (7) Sharp bending should be avoided on FPC to prevent track cracking.

##### 2.2 Static Electricity

MDL contains CMOS LSI's and the same precaution for such devices should apply, namely:

- (1) The operator should be grounded whenever he comes into contact with the module. Never touch any of the conductive parts such as the LSI pads, the copper leads on the PCB and the interface terminals with any part of the human body.
- (2) The modules should be kept in antistatic bags or other containers resistant to static for storage.
- (3) Only properly grounded soldering irons should be used.
- (4) If an electric screwdriver is used it should be well grounded and shielded from commutator sparks.
- (5) The normal static prevention measures should be observed for work clothes and working benches; for the latter conductive (rubber) mat is recommended.
- (6) Since dry air is inductive to statics, a relative humidity of 50 - 60% is recommended.

##### 2.3 Soldering

- (1) Solder only to the I/O terminals.
- (2) Use only soldering irons with proper grounding and no leakage.
- (3) Soldering temperature is 280°C ± 10°C.
- (4) Soldering time: 3 to 4 seconds.
- (5) Use eutectic solder with resin flux fill.
- (6) If flux is used, the LCD surface should be covered to avoid flux spatters. Flux residue should be removed afterwards.
- (7) Use proper de-soldering methods (e.g. suction type desoldering irons) to remove lead wires from the I/O terminals when necessary. Do not repeat the soldering/ desoldering process more than three times as the pads and plated through holes may be damaged.

##### 2.4 Label

Identification labels will be stuck on the module without

obstructing the viewing area of display.

#### 3. Operation

- (1) The viewing angle can be adjusted by varying the LCD driving voltage  $V_o$ .
- (2) Driving voltage should be kept within specified range, excess voltage shortens display life.
- (3) Response time increases with decrease in temperature.
- (4) Display may turn black or dark Blue at temperatures above its operational range; this is however not destructive and the display will return to normal once the temperature falls back to range.
- (5) Mechanical disturbance during operation (such as pressing on the viewing area) may cause the segments to appear "fractured". They will recover once the display is turned off.
- (6) Condensation at terminals will cause malfunction and possible electrochemical reaction. Relative humidity of the environment should therefore be kept below 60%.
- (7) Display performance may vary out of viewing area. If there is any special requirement on performance out of viewing area, please consult Varitronix.

#### 4. Storage and Reliability

- (1) LCD's should be kept in sealed polyethylene bags while MDL's should use antistatic ones. If properly sealed, there is no need for desiccant.
- (2) Store in dark places and do not expose to sunlight or fluorescent light. Keep the temperature between 0°C and 35°C and the relative humidity low. Please consult VARITRONIX for other storage requirements.
- (3) Water condensation will affect reliability performance of the display and is not allowed.
- (4) Semi-conductor device on the display is sensitive to light and should be protected properly.
- (5) Power up/down sequence.
  - a) Power Up: in general, LCD supply voltage,  $V_o$  must be supplied after logic voltage, VDD becomes steady. Please refer to related IC data sheet for details.
  - b) Power Down: in general, LCD supply voltage,  $V_o$  must be removed before logic voltage, VDD turns off. Please refer to related IC data sheet for details.

#### 5. Safety

If any fluid leaks out of a damaged glass cell, wash off any human part that comes into contact with soap and water. Never swallow the fluid. The toxicity is extremely low but caution should be exercised at all times.

### LIMITED WARRANTY

VARITRONIX LCDs and modules are not consumer products, but may be incorporated by VARITRONIX's customers into consumer products or components thereof. VARITRONIX does not warrant that its LCDs and components are fit for any such particular purpose.

1. The liability of VARITRONIX is limited to repair or replacement on the terms set forth below. VARITRONIX will not be responsible for any subsequent or consequential events or injury or damage to any personnel or user including third party personnel and/or user.

Unless otherwise agreed in writing between VARITRONIX and the customer, VARITRONIX will only replace or repair any of its LCD which is found defective electrically or visually when inspected in

accordance with VARITRONIX LCD Acceptance Standards (copies available on request), for a period of one year from the date of shipment. Confirmation of such date shall be based on freight documents.

2. No warranty can be granted if any of the precautions stated in HANDLING LCD and LCD Modules above have been disregarded. Broken glass, scratches on polarizers, mechanical damages as well as defects that are caused by accelerated environmental tests are excluded from warranty.
3. In returning the LCD and Modules, they must be properly packaged and there should be detailed description of the failures or defects.

### IMPORTANT NOTICE

The information presented in this document has been carefully checked and is believed to be accurate, however, no responsibility is assumed for inaccuracies. VARITRONIX reserves the right to make changes to any specifications without further notice for performance, reliability, production technique and other considerations. VARITRONIX does not assume any liability arising out of the application or use of products herein. Please see Limited Warranty in the previous section.

Varitronix Limited reserves the right to change this specification."

Tel:(852) 2197-6000

Fax:(852) 2343-9555.

URL:<http://www.varitronix.com>

- END -