

LOC		DIST		REVISIONS			
GP	00	REV	DATE	BY	CHK	APPV	
B1		REVISED PER ECO-11-004835	11MAR11	RK	HMR		

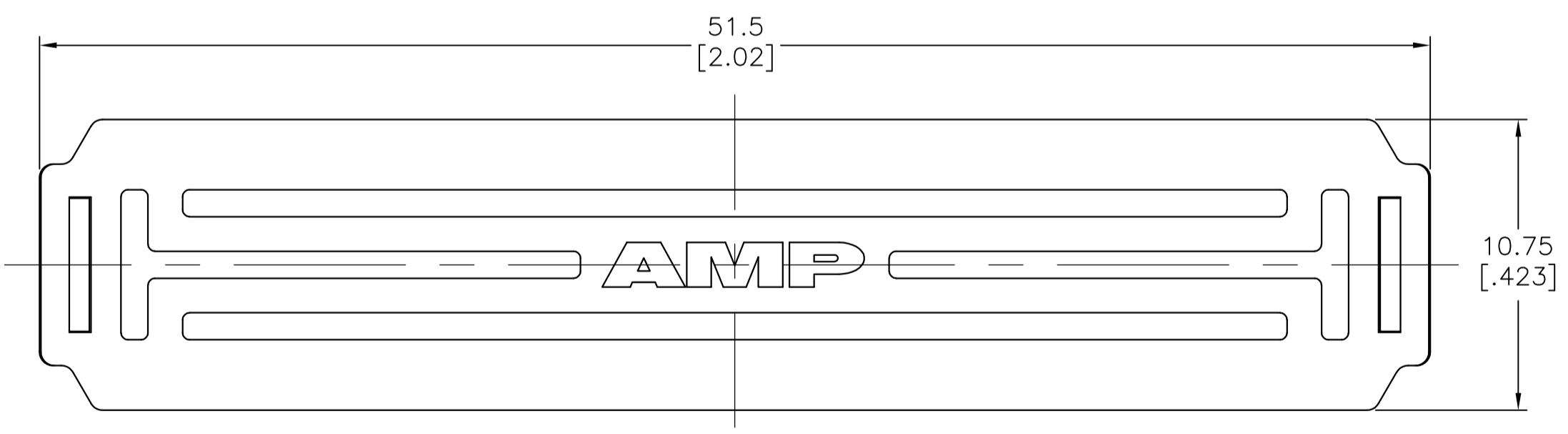

- △ HOUSING & COVER: PBT 30% GLASS FILLED, UL 94V-0 RATED, COLOR BLACK. CONTACTS: PHOSPHOR BRONZE.
- △ CONTACTS: 0.00076[.000030] MIN GOLD ON MATING END, 0.00127[.000050] MIN TIN ON TERMINATION END, ALL OVER 0.00127[.000050] MIN NICKEL ON ENTIRE CONTACT.
- △ CONTACTS: 0.00038[.000015] MIN GOLD ON MATING END, 0.00127[.000050] MIN TIN ON TERMINATION END, ALL OVER 0.00127[.000050] MIN NICKEL ON ENTIRE CONTACT.
- 4. RECOMMENDED WIRE: 30 AWG OR 31 AWG, SOLID OR STRANDED, FLAT RIBBON CABLE, PVC INSULATION.
- 5. DIMENSIONS SHOWN ARE FOR 68 POSITION ASSEMBLY.

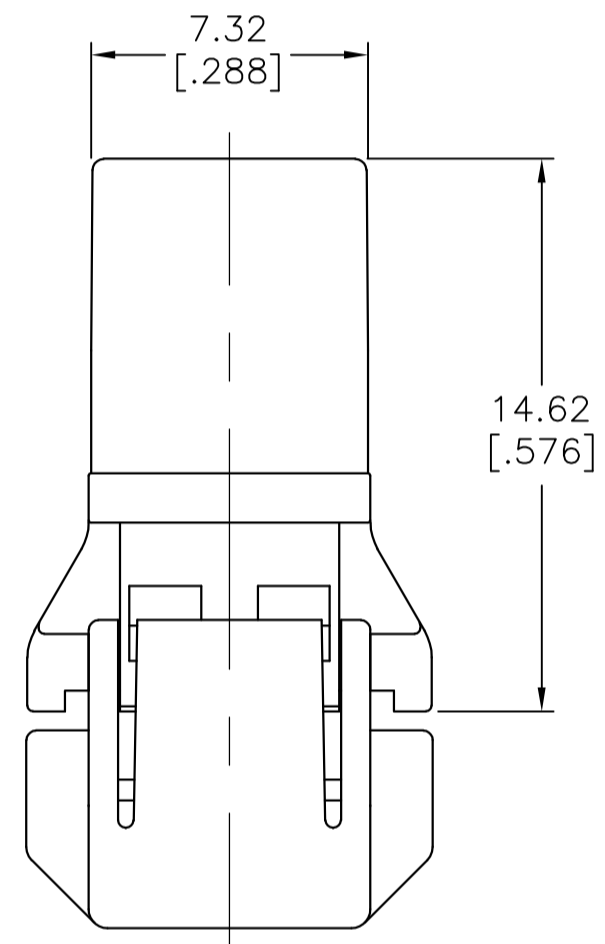
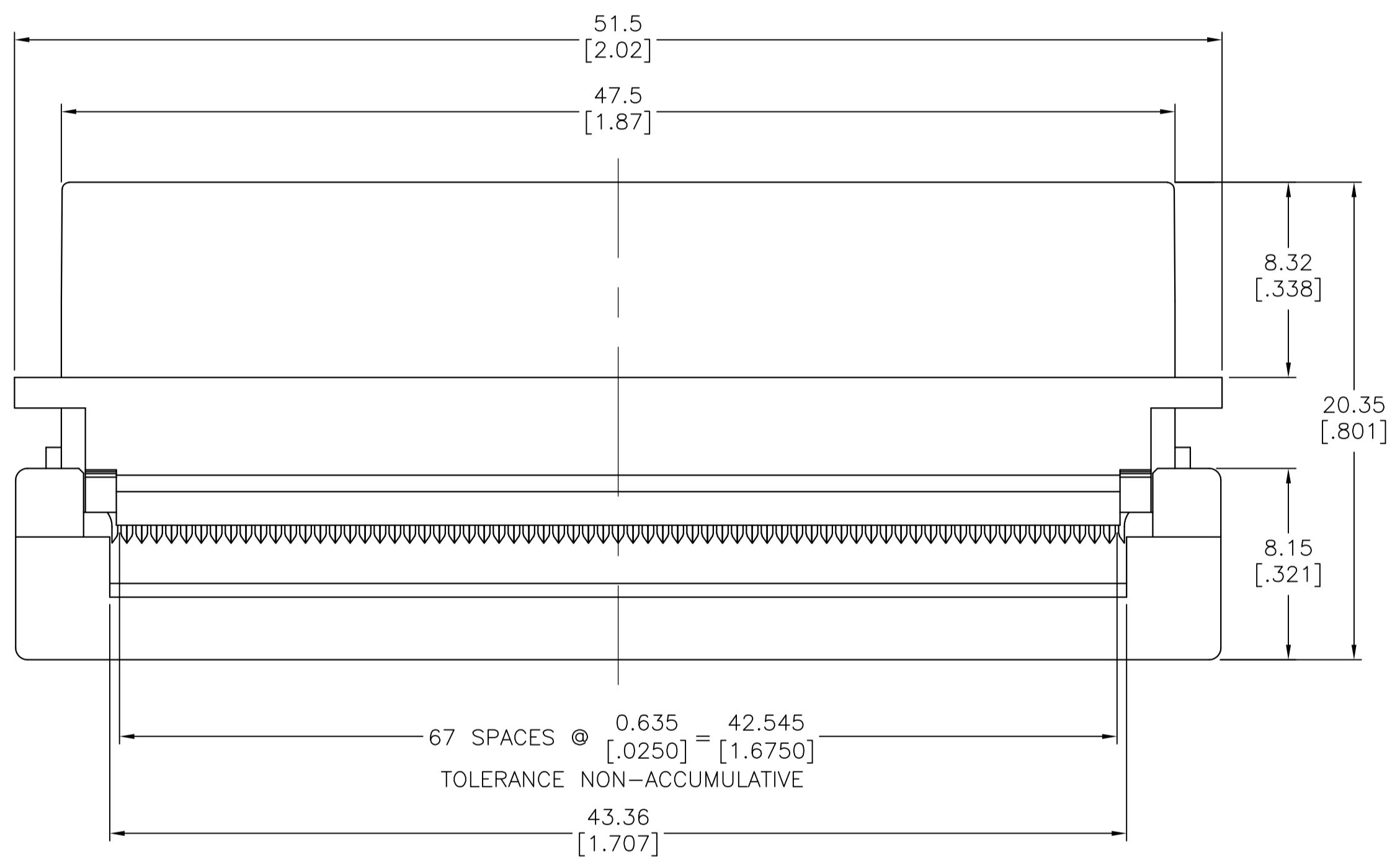
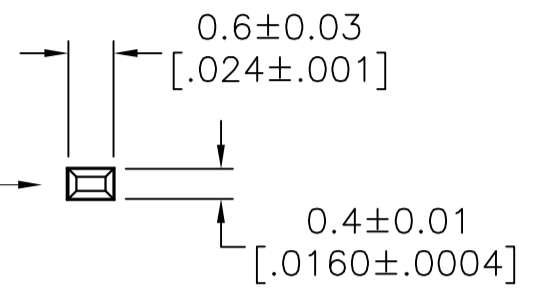
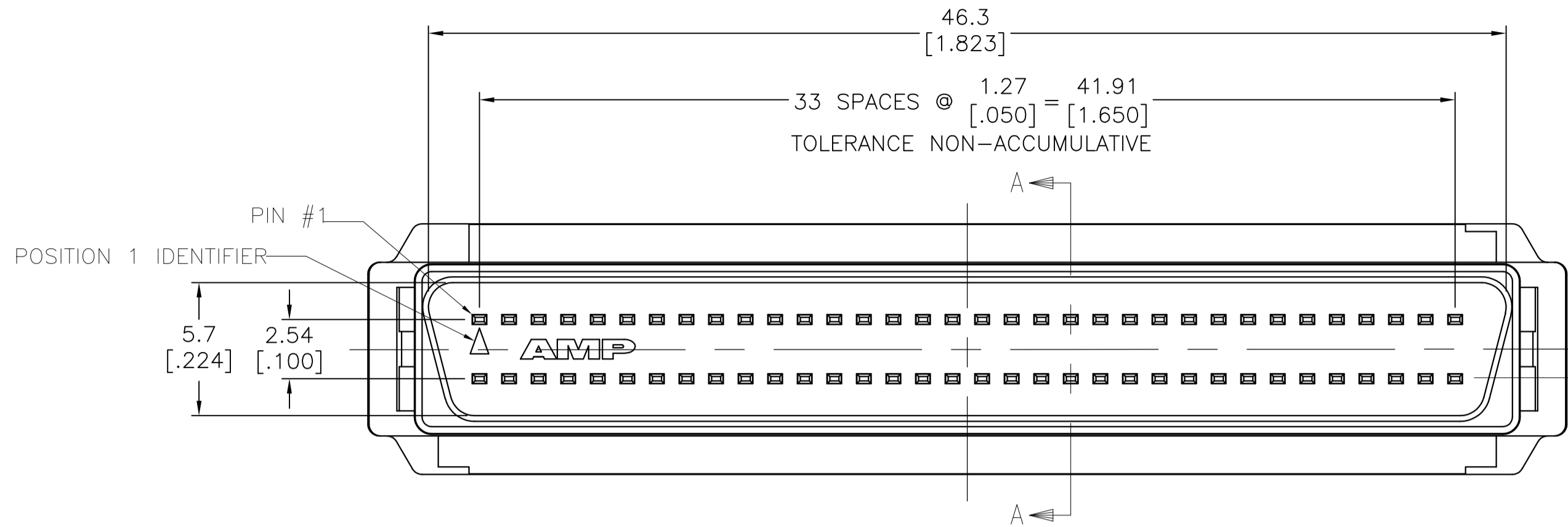
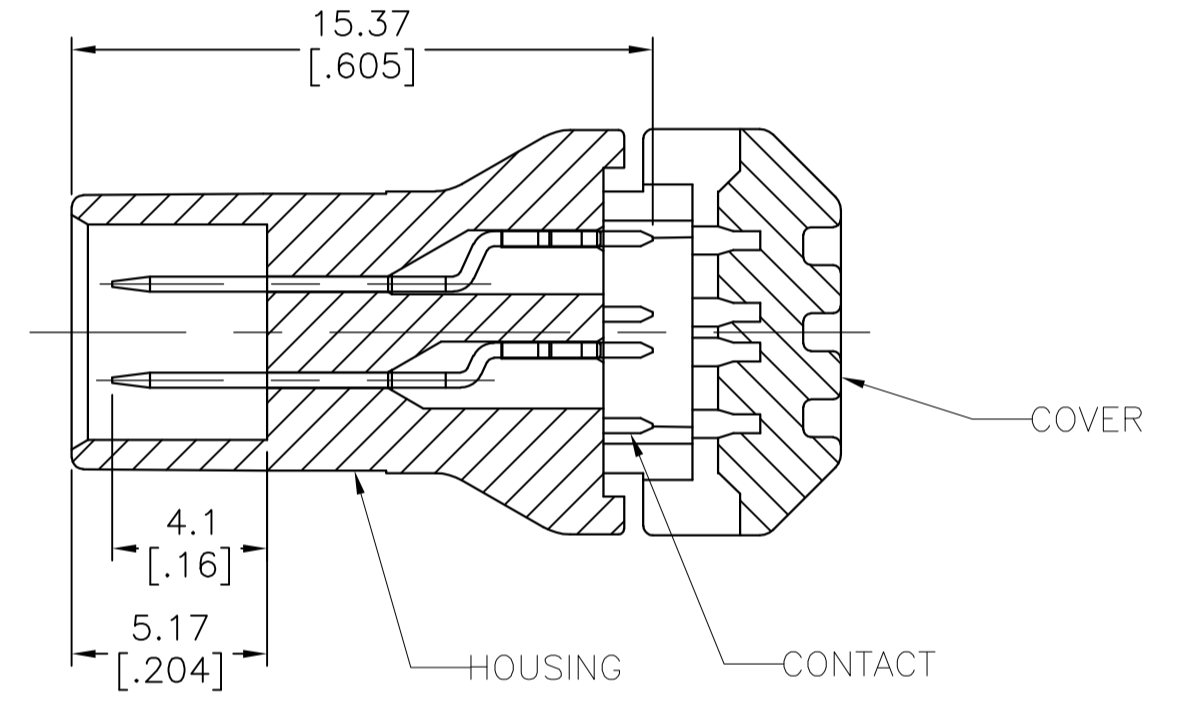

SECTION A-A

OBSOLETE	TUBE	△	68	1-5786090-7
	TUBE	△	68	5786090-7
	PACKAGING	CONTACT FINISH	NO OF POS	PART NUMBER

THIS DRAWING IS A CONTROLLED DOCUMENT.		DIN L VARELA - DOCKS 02-18-05		S BOLAISH 02-18-05		M WALMSLEY 02-18-05		NAME		TE Connectivity	
DIMENSIONS: mm [INCHES]		TOLERANCES UNLESS OTHERWISE SPECIFIED:		PRODUCT SPEC		APPLICATION SPEC		SIZE		RESTRICTED TO	
0 PL ± -		1 PL ± 0.35[.014]		108-1359		114-40049		A1		CUSTOMER DRAWING	
2 PL ± 0.25[.010]		3 PL ± 0.15[.006]		108-1359		114-40049		A1		SCALE 1:1 SHEET 1 OF 1 REV B1	
4 PL ± -		ANGLES ± -		114-40049		114-40049		A1		SCALE 1:1 SHEET 1 OF 1 REV B1	
MATERIAL		FINISH		WEIGHT		SCALE		SHEET		REV	
SEE TABLE		SEE TABLE		-		1:1		1 OF 1		B1	