

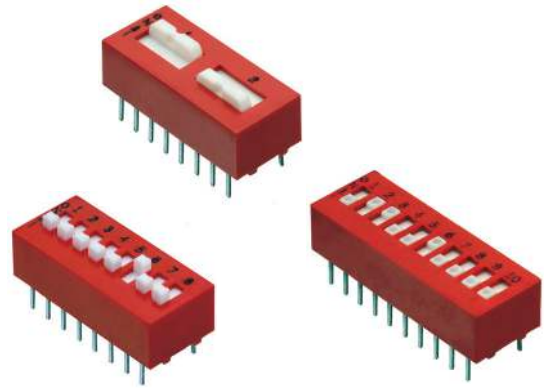

# Thru-Hole DIP Switches

## SERIES 78 SPST To 4PST Slide

- ### FEATURES
- Raised and Recessed Slides
  - SPST, 2PST, 3PST, 4PST
  - Sealed Base Standard
  - Spring and Ball Contact
  - Top Tape Seal Option

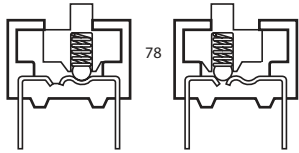

DIP Switches

### DIMENSIONS In inches (and millimeters)

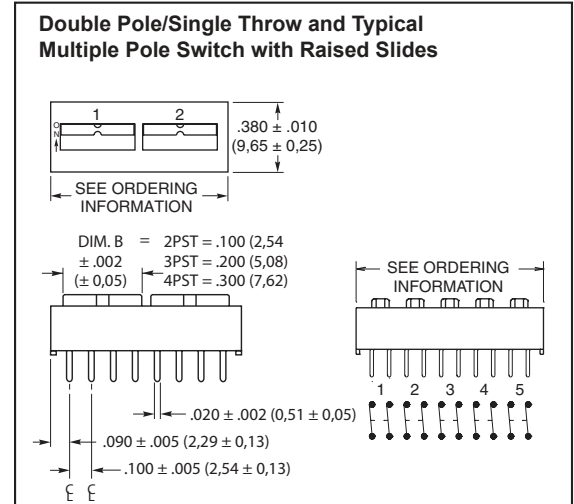
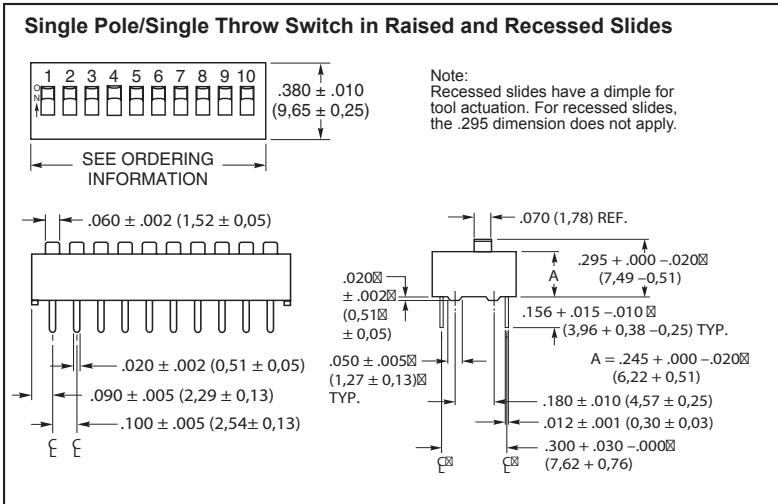

### CIRCUITRY

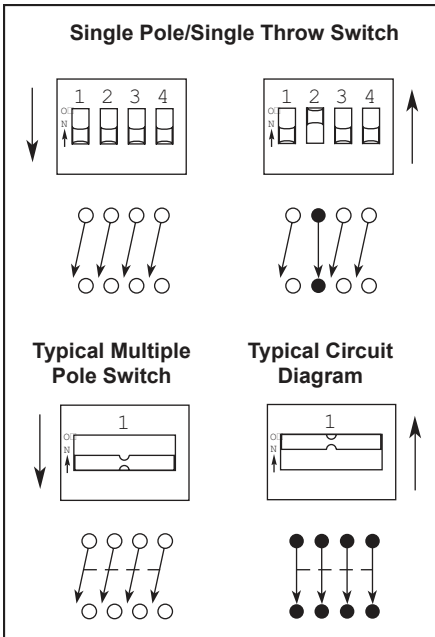

For switches with 5, 6, 7, 8, or 10PST circuitry, contact Grayhill.

### ORDERING INFORMATION

Circuitry	No. of Positions	Length Inches	Length Metric	No./ Tube	Raised Slides*	Recessed Slides*	
SPST	2	0.280"	7,1mm	35	78B02T	78RB02T	
	3	0.380"	9,7mm	27	78B03T	78RB03T	
	4	0.480"	12,2mm	21	78B04T	78RB04T	
	5	0.580"	14,7mm	18	78B05T	78RB05T	
	6	0.680"	17,3mm	15	78B06T	78RB06T	
	7	0.780"	19,8mm	13	78B07T	78RB07T	
	8	0.880"	22,4mm	12	78B08T	78RB08T	
	9	0.980"	24,9mm	10	78B09T	78RB09T	
	10	1.080"	27,4mm	9	78B10T	78RB10T	
	12	1.280"	32,5mm	8	78B12T	78RB12T	
	2PST	1	0.280"	7,1mm	35	78F01T	Recessed Slides Not Available
		2	0.480"	12,2mm	21	78F02T	
3		0.680"	17,3mm	15	78F03T		
4		0.880"	22,4mm	12	78F04T		
5		1.080"	27,4mm	9	78F05T		
6		1.280"	32,5mm	8	78F06T		
3PST	1	0.380"	9,7mm	27	78G01T	Recessed Slides Not Available	
	2	0.680"	17,3mm	15	78G02T		
	3	0.980"	24,9mm	10	78G03T		
4PST	1	0.480"	12,2mm	21	78H01T	Recessed Slides Not Available	
	2	0.880"	22,4mm	12	78H02T		

\*A top tape seal is required for switches that are machine soldered or heavily cleaned after hand soldering. To order top seal versions, add "S" to the Grayhill part number.

**Available from your local Grayhill Distributor.**  
 For prices and discounts, contact a local Sales Office, an authorized local Distributor or Grayhill.

**SPECIFICATIONS: Standard Styles**

<b>Ratings</b>	<b>76</b>	<b>78</b>	<b>90B</b>
<b>Mechanical Life:</b> Operations per switch position	2,000	2,000	2,000
<b>Make-and-break Current Rating:</b> Operations per switch position at these resistive loads 1 mA, 5 Vdc; 50 mA, 30 Vdc; or 150 mA, 30 Vdc:	2,000	2,000	—
10 mA, 30 Vdc; or 10 mA, 50 mVdc:	—	—	2,000
10 mA, 50 mVdc; or 25 mA, 24 Vdc; or 100 mA, 6 Vdc:	—	—	2,000
<b>Contact Resistance:</b> Initially:	≤ 30 mΩ	≤ 30 mΩ	≤ 20 mΩ
After life, at 10 mA, 50 mVdc, open circuit:	≤ 100 mΩ	≤ 100 mΩ	≤ 100 mΩ
<b>Insulation Resistance:</b> Minimum, at 100 Vdc between adjacent closed contacts and also across open switch contacts			
Initially (Mohms):	5,000	5,000	5,000
After life (Mohms):	1,000	1,000	1,000
<b>Dielectric Strength:</b> Minimum voltage (AC, RMS) measured between adjacent closed contacts and also across open switch contacts.			
Initially:	750 V	750 V	500 V
After life:	500 V	500 V	500 V
<b>Current Carry Rating:</b> Maximum rise of 20°C	5 A	4 A	3 A
<b>Switch Capacitance:</b> At 1 megahertz	2 pF	2 pF	2 pF
<b>Operating Temperature Range:</b>	-40°C to + 85°C	-40°C to + 85°C	-40°C to + 85°C
<b>Storage Temperature Range:</b>	-55°C to + 85°C	-55°C to + 85°C	-55°C to + 85°C

DIP Switches

**Mechanical Ratings**

**Vibration Resistance:** Per Method 204, Test Condition B, 1 mS opening (10 mS allowed)  
**Mechanical Shock:** Per Method 213, Test Condition A, 1 mS opening (10 mS allowed)  
**Thermal Shock Resistance:** Per specification; no failures; passes contact resistance.  
**Terminal Strength:** Per specification  
**Thermal Aging:** 1,000 hours at 85°C; no failures.

**Environmental Ratings**

Meets all requirements of MIL-S-83504. Where Grayhill performance is superior, the MIL spec is listed in parentheses.  
**Moisture Resistance:** Per specification, Method 106.

**Soldering Information**

Series 90 MIDIP® and Series 76 recessed rocker (76RSB style) sealed switches have been tested to EIA Standard RS-448-2. Similar performance can be expected from other sealed Series 76 and 78 DIP switches.  
**Solderability:** Per MIL-STD-202, Method 208  
**Resistance to Soldering Heat:** 76RSB: Passes EIA Standard using two, four, and six second soldering time. 90: Per MIL-S-83504, six second test.  
**Fluxing:** Per EIA RS-448-2 with flux touching switch body.  
**Cleaning:** 76, 78 and 90 Series tape sealed products: Passes immersion test using water/detergent. Acceptable solutions include 1-1-1 trichlorethane, freon, (TF, TE, or TMS), isopropyl alcohol, detergent (140°F maximum). Terpene acceptable for Series 90 only. Solutions which are not recommended include acetone, methylene chloride, freon TMC.

**Materials and Finishes**

**Shorting Member (Ball):** Brass, gold-plated 10 microinches minimum over nickel barrier.  
**Base Contacts:** Copper alloy, gold-plated over nickel barrier.  
**Terminals:** Copper alloy, matte-tin plated over nickel barrier.  
**Non-Conductive Parts:** Thermoplastic (UL94V-O)  
**Potting Material:** Epoxy, 76,78 only.  
**Protective Cover:** 76,78, only-Polycarbonate.

**Tape and Reel Packaging**

**Tape Seal:**  
 76, 78: Polyester film  
 90: Polyimide film  
**Tape Seal Integrity:** Passes gross leak test using 125°C flourinert for 20 seconds minimum. Reference MIL-STD-202, Method 112.



## Grayhill DIP Switch Processing Information

The information provided within is intended as processing guidelines for the assembly, soldering, cleaning, and use of Grayhill DIP switches. This information supersedes any other process information that is available in Grayhill Inc. catalogs or data sheets as related to Grayhill Inc. standard DIP switch products. Please contact Grayhill Inc. for any questions related to the information in this document.

### Mounting

Unless otherwise noted, Grayhill DIP switches are shipped with slides or rockers in the ON position and rotary DIP switches are shipped with the actuators in the 0 position. It is recommended that they be solder processed in those positions to ensure proper performance without issue.

### Soldering

**WAVE SOLDER:** Switches that can be processed using wave solder equipment (thru hole soldering) are as follows:

Grayhill Series 76SB, 76PSB, 76RSB, 76SC, 76RSC, 76RSD, 76SD, 76STC, 76STD, 78B, 78RB, 78F, 78G, 78H, 78J, 78K, 90B, 94H (thru hole models), and 94R

Wave soldering guidelines: Solder wave temperature is 260°C. max. for 5 seconds max. (0.063" thick PCB). Exposure to flux should be kept to a minimum.

Manual soldering guidelines (for thru hole switches): Soldering temperature is 350C for soldering iron tip with 3 seconds maximum of dwell time.

**REFLOW SOLDER:** Switches that can be processed using reflow process equipment are as follows:

Grayhill Series 76HP, 78HF, 78HJ, 90B, 90HB, 94H, 94R, 97C, and 97R

Reflow soldering guidelines: Soldering temperature is 260C max. for 5 seconds, with a maximum of two reflow cycles at the maximum conditions. Switches should be allowed to cool for 3 to 5 minutes between reflow cycles. Reflow soldering should not be done to any Grayhill DIP switch products not listed directly above as the exposure to higher surface temperatures could cause permanent deformation of the plastic materials.

### Recommended Maximum Soldering Conditions:

#### Reflow Soldering Profile:

(260°C Peak Temperature)

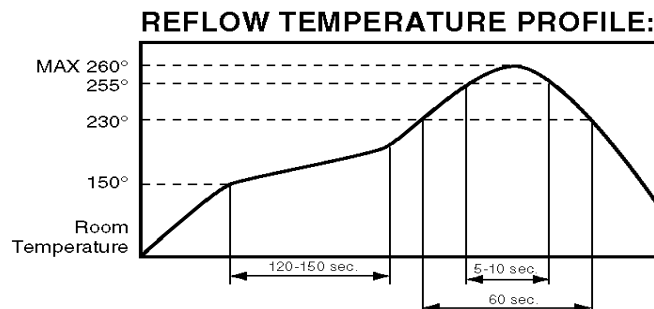

### PCB Cleaning

In-line DIP switches that are tape sealed can be processed using certain washing processes as described below. Tape sealed switches can typically be identified by a suffix of ST or PT that follows after the series, switch style, and number of position identifiers (i.e., 76SB08ST). Non-tape sealed switches should not be subjected to any washing processes as they can introduce contaminants into the contact area of the switches. Rotary DIP products (94H & 94R) are internally sealed and can be processed the same as tape sealed products.

Tape sealed and rotary DIP switch products are qualified for immersion cleaning processes using alcohol or detergent based cleaning solvents at temperatures up to 140°F. maximum. Tape seal products must have the tape seal undisturbed until after any cleaning process. Cleaning processes that use ultrasonic agitation or that use pressurized sprays can defeat the tape and / or internal seals and allow contamination of the switches. They are not recommended for use on inline or rotary DIP products. Switches should not be washed directly after a soldering process. There should be a delay of at least three minutes to allow adequate time for cooling after soldering.

Tape seal integrity: Inline DIP products that are tape sealed are tested to meet and pass a gross leak test using 125°C Fluorinert for 20 seconds minimum. Reference MIL-202, Method 112.

Tape seal material:

76,78: Polyester film, rated to 170°F. maximum temperature

90: Polyimide film, rated to 260°C. maximum temperature