

# IMI111T - iMOTION™ IPM for motor control

## Fully integrated high-performance turnkey motor control system

IMI111T

### Features

- Motion Control Engine (MCE) as a ready-to-use control solution for variable speed drives
- Integrated script engine for application control customization
- Integrated drive and system protection features
- Field oriented control (FOC) for permanent magnet synchronous motor (PMSM)
- Flexible space vector PWM for sinusoidal voltage control
- Current sensing via single shunt
- Sensorless operation
- Integrated analog comparators for over-current protection
- Built-in temperature sensor
- Flexible control input options: UART or analog signal
- Certified drive safety functions according to IEC/UL 60730-1 'Class B'
- High voltage three phase gate driver with 600 V blocking voltage
- 15 V supply voltage for gate driver
- Integrated boot strap diode structure
- Isolation 1500 V<sub>RMS</sub> 1 min
- 3.3 V or 5.0 V controller supply voltage
- 2 different IGBT options: 2 A/600 V and 4 A/600 V
- Optimized dv/dt for loss and EMI trade offs
- Very compact DSO-22 package

### Potential applications

- Small and major home appliances
- Fans, Pumps, Compressors
- General purpose variable speed drives

### Product validation

Qualified for industrial applications according to the relevant tests of JEDEC47/20/22.

**Description**

**Description**

IMI111T devices belong to IMI110 series of iMOTION™ IPMs. IMI111T is a family of fully-integrated, turnkey high-voltage motor drive modules designed for high-performance, high-efficiency PMSM/BLDC motor drive applications such as fans, pumps and small compressors.

IMI111T integrates the motor controller, a 3-phase high-voltage, rugged gate driver with integrated bootstrap functionality and six 600 V TRENCHSTOP™ IGBTs (Reverse Conducting Drive 2). Depending on the IGBTs employed in the package, IMI111T covers applications with 600 V maximum DC voltage. For a typical fan application using 16kHz PWM rate and 2-phase switching an output power of 50 W and 70 W can be achieved without the use of a dedicated heatsink.<sup>1)</sup>

It uses a compact and low cost DSO-22 surface-mount package which minimizes external components count and PCB area and features a 2.2 mm creepage distance between the high-voltage pads to increase the robustness of the system.

The motor controller uses the Motion Control Engine (MCE) to create a ready-to-use solution to perform control of a permanent magnet synchronous motor (PMSM) providing the shortest time to market for any motor system at the lowest system and development cost. The integrated script engine allows to add application flexibility without interfering with the motor control algorithm.

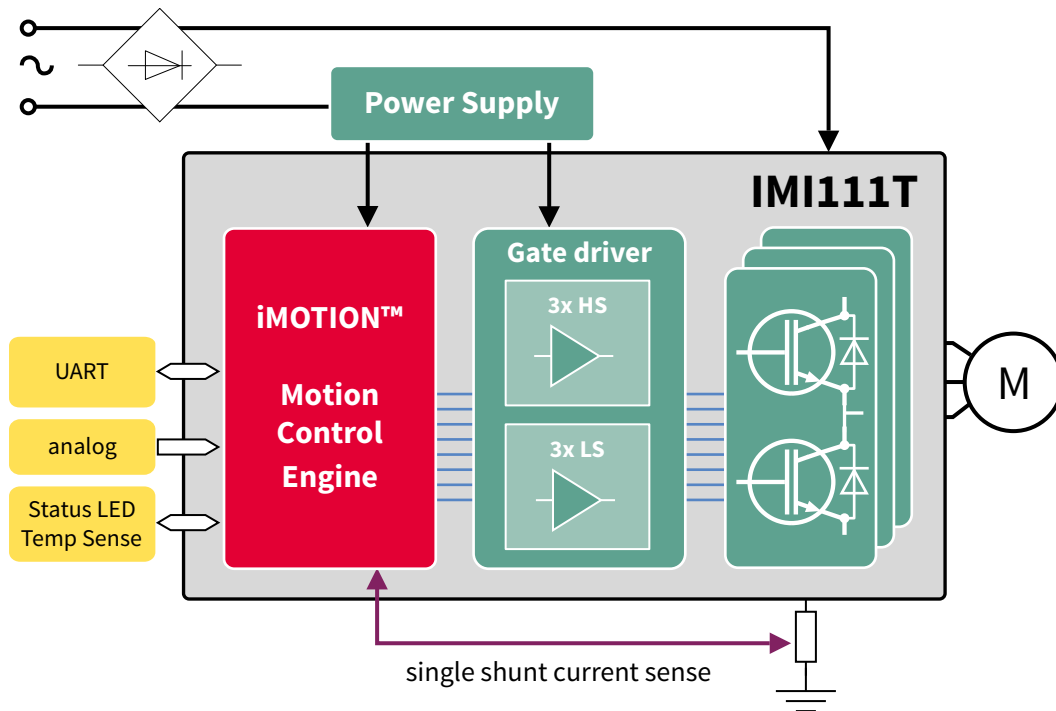

**Ordering information**

Product type	Control function integrated	Output rating
IMI111T-026H	iMOTION™ MCE for motor control	600 V/2 A
IMI111T-046H	iMOTION™ MCE for motor control	600 V/4 A

<sup>1)</sup> This assumes the Rth(C-A) value of a PCB thermal design is equal or lower than the value specified in Thermal characteristics and delta Tca = 60C.

## Table of contents

	<b>Features</b> .....	1
	<b>Potential applications</b> .....	1
	<b>Product validation</b> .....	1
	<b>Description</b> .....	2
	<b>Table of contents</b> .....	3
<b>1</b>	<b>Block diagram reference</b> .....	5
<b>2</b>	<b>Pin types and pad structure</b> .....	6
2.1	Pin definitions and functions .....	7
2.2	Pin configuration drawing IMI111T .....	8
<b>3</b>	<b>Functional description</b> .....	9
3.1	Overview .....	9
3.2	Motion Control Engine .....	9
3.3	Gate driver function .....	10
3.3.1	Features and protections .....	10
3.3.2	Block diagram .....	11
3.3.3	I/O structure .....	12
3.4	IGBTs .....	12
3.5	Application diagrams .....	12
<b>4</b>	<b>Electrical characteristics and parameters</b> .....	13
4.1	General parameters .....	13
4.1.1	Parameter Interpretation .....	13
4.1.2	Absolute maximum ratings .....	13
4.1.3	Pin Reliability in Overload .....	14
4.1.4	Operating Conditions .....	16
4.2	DC characteristics .....	16
4.2.1	Input/Output Characteristics .....	16
4.2.2	Analog to Digital Converter (ADC) .....	18
4.2.3	Analog comparator characteristics .....	18
4.2.4	Power Supply Current Controller .....	19
4.2.5	Flash Memory Parameters .....	19
4.2.6	Under voltage lockout DC characteristics .....	20
4.2.7	Power Supply Current Gate Driver .....	21
4.2.8	IGBT .....	21
4.2.9	Diode .....	21
4.3	AC characteristics .....	23
4.3.1	Testing Waveforms .....	23
4.3.2	Power-Up and Supply Threshold Characteristics .....	23

**Table of contents**

4.3.3	On-Chip Oscillator Characteristics .....	25
4.3.4	IGBT .....	25
4.3.5	Diode .....	26
4.4	Motor Control Parameters .....	27
4.4.1	PWM Characteristics .....	27
4.4.2	Current Sensing .....	27
4.4.3	Fault Timing .....	28
4.5	Device Interfaces .....	29
4.5.1	UART Interface .....	29
4.5.2	Analog Speed Input .....	30
<b>5</b>	<b>Device and package specifications</b> .....	<b>31</b>
5.1	Quality declaration .....	31
5.2	SBSL and Chip-IDs .....	31
5.3	Thermal characteristics .....	31
5.4	Typical performance .....	32
5.5	Package outline PG-DSO-22-1 .....	33
5.6	Part marking information .....	33
	<b>Revision history</b> .....	<b>34</b>
	<b>Disclaimer</b> .....	<b>35</b>

1 Block diagram reference

1 Block diagram reference

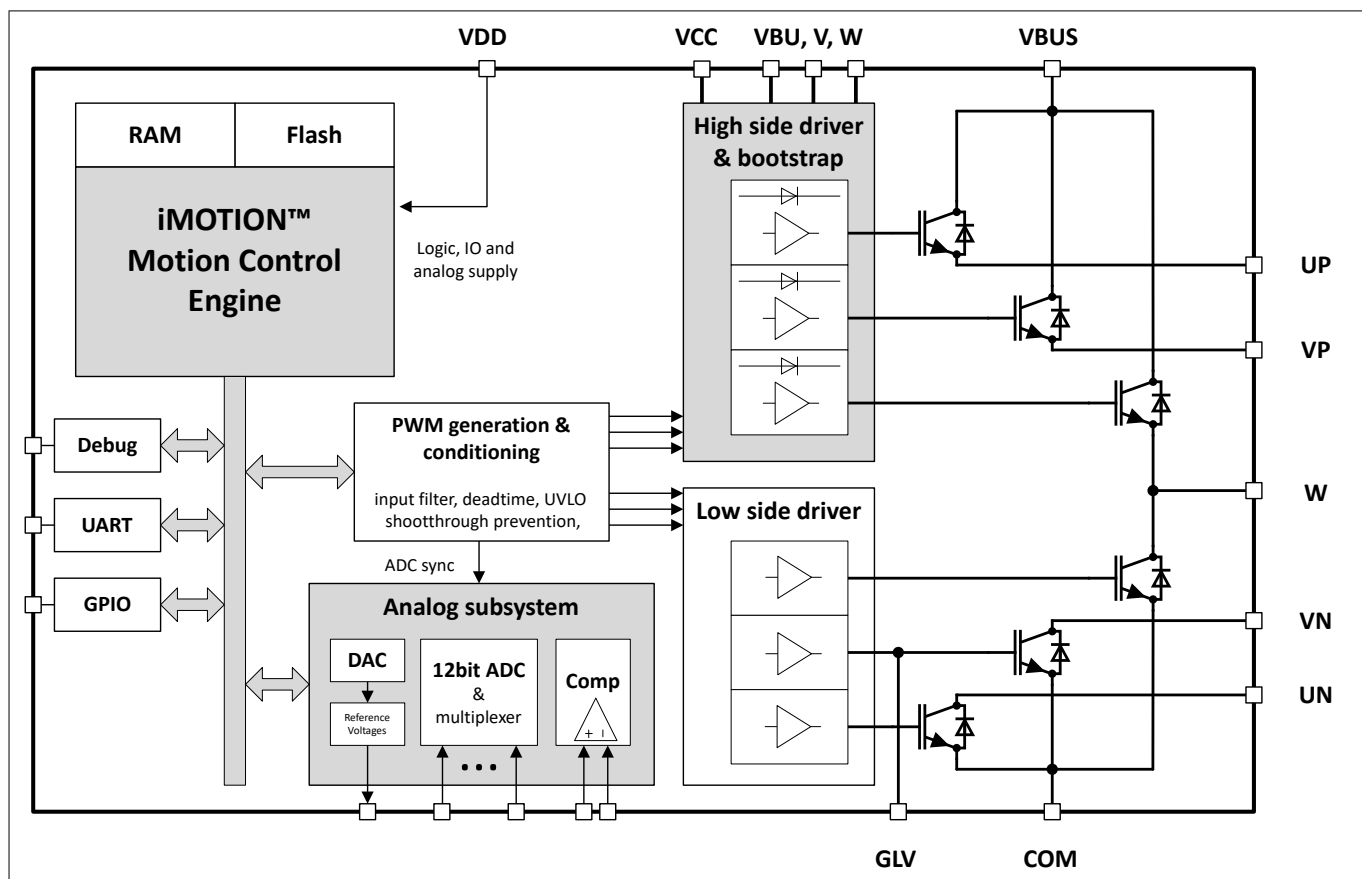

Figure 1 Block diagram reference

**2 Pin types and pad structure**

**2 Pin types and pad structure**

The pin type is specified as follows:

- P - power
- I - digital input
- O - digital output
- IO – digital input or output
- AIN - analog input
- AO - analog output

Figure 2 shows the pad structure and pin function control configuration for the input and output pins of the controller integrated.

The pin function, type and pull up/pull down circuit configuration are all controlled by the Motion Control Engine. Digital input, output or analog input signals that are not assigned to MCE functions can be assigned to the script engine. The gate driver outputs are controlled by MCE PWM signals internally connected to the gate driver inputs.

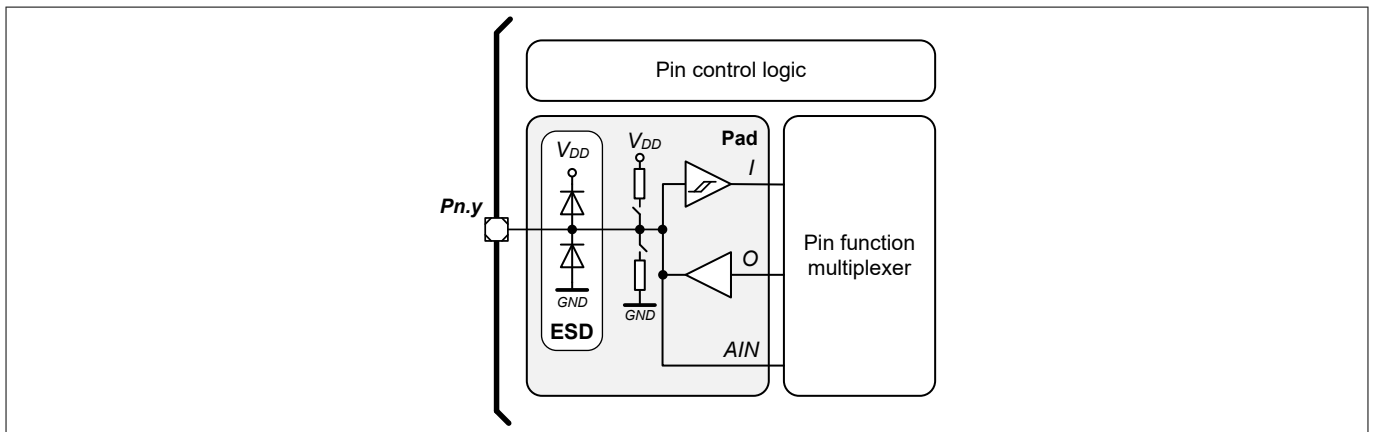

**Figure 2 Pin Pad and Function Configuration**

The pin function table given below refers to the standard configuration. The pin control or interface functions are defined by the version of software downloaded to the device and may change. Some of the input pins can be configured to have pull up or pull down resistor and some output pins can be configured to push-pull or open drain. This is described in the respective software reference manual.

Pins can serve multiple functions and have to be configured accordingly. Please also refer to the respective pin configuration drawings in this data sheet and the description in the MCE software reference manual.

Pins that do not have any signal assigned are reserved for future use. These pins should be left unconnected and neither be connected to ground nor to the positive supply.

*Note: All required reference voltages are generated by an internal DAC, therefore the AO pins like IREF, REFU, REFV, and REFW only require a blocking capacitor.*

**2 Pin types and pad structure**

**2.1 Pin definitions and functions**

**Table 1 Pin definitions and functions**

<b>Pin</b>	<b>Name</b>	<b>Type</b>	<b>Description</b>
1	<i>TX0</i> / <i>PGOUT</i> / <i>GPIO1</i>	IO	Serial port transmit output / pulse output/ digital IO
2	<i>RX0</i> / <i>DIR</i> / <i>GPIO6</i>	IO	Serial port receive input / direction input/ digital IO
3	<i>VSP</i>	AIN	Analog speed reference input
4	<i>ISS</i>	AIN	Current sense input single shunt
5	<i>VDC</i>	AIN	DC bus sensing input
6	<i>IREF</i>	O	Over current reference DAC output
7	<i>VDD</i>	P	Digital controller supply
8	<i>VCC</i>	P	Low side gate driver supply
9	<i>VSS</i>	P	Control signal ground
10	<i>GLV</i>	NC	Gate of low side IGBT of phase V (do not connect on PCB)
11	<i>COM</i>	P	3-phase low side IGBT common emitter return
12	<i>UN</i>	P	U phase low side IGBT collector (PCB connection to UP required)
13	<i>VN</i>	P	V phase low side IGBT collector (PCB connection to VP required)
14	<i>W/VSW</i>	P	W phase output (bootstrap capacitor connection -)
15	<i>W/VSW</i>	P	W phase output (bootstrap capacitor connection -)
16	<i>VBW</i>	P	W phase high side floating supply (bootstrap capacitor connection +)
17	<i>VBUS</i>	P	DC bus voltage
18	<i>VBUS</i>	P	DC bus voltage
19	<i>VBV</i>	P	V phase high side floating supply (bootstrap capacitor connection +)
20	<i>VP</i>	P	V phase high side IGBT emitter (PCB connection to VN required)
21	<i>VBU</i>	P	U phase high side floating supply (bootstrap capacitor connection +)
22	<i>UP</i>	P	U phase high side IGBT emitter (PCB connection to UN required)

**2 Pin types and pad structure**

**2.2 Pin configuration drawing IMI111T**

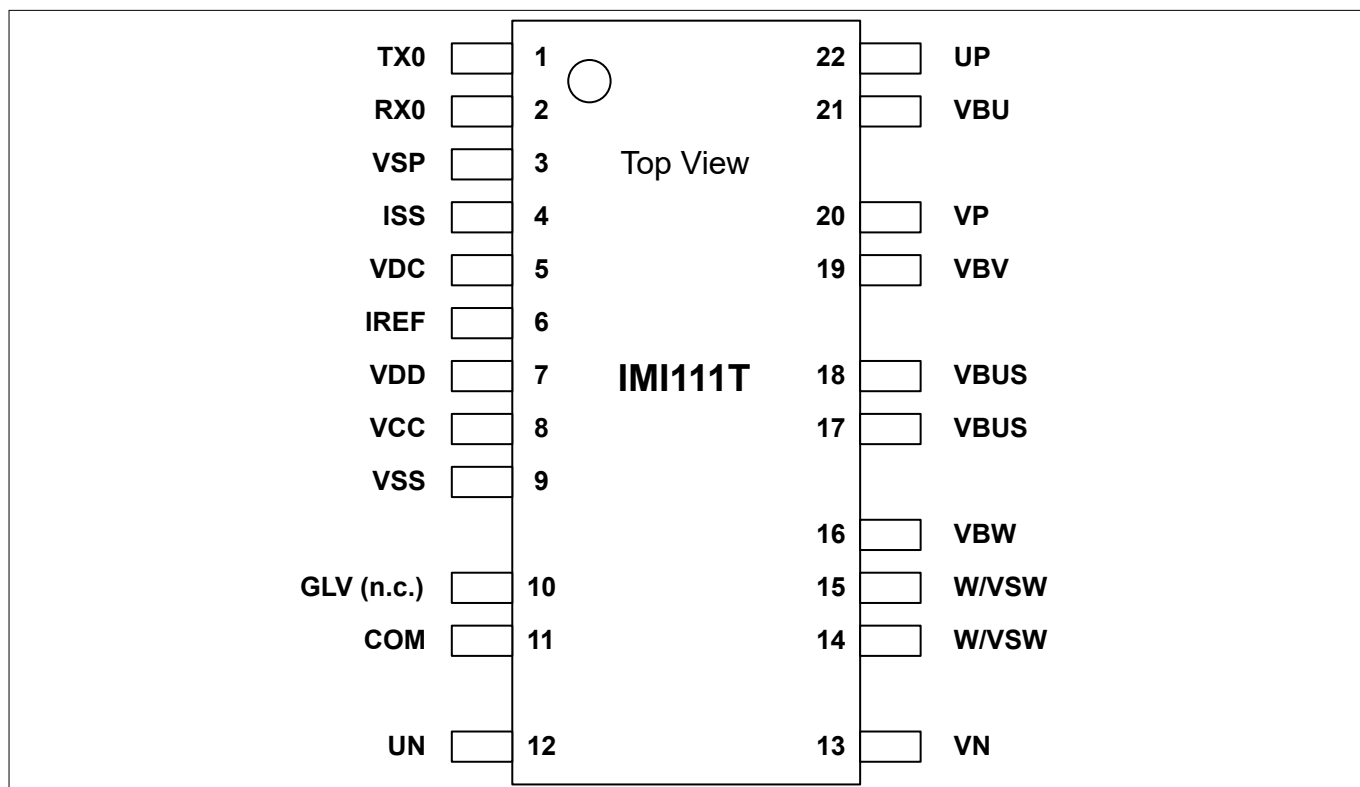

**Figure 3 Pin assignment**



### **3 Functional description**

## **3 Functional description**

### **3.1 Overview**

The IMI111T integrates a controller, a high-voltage three-phase gate driver and six reverse conducting IGBTs in a single package. The controller PWM outputs are internally connected to the gate driver inputs that drives the six IGBTs. The high side drive voltages can be generated via bootstrap capacitors connected to the respective pins. The package PG-DSO-22-1 is footprint compatible to a standard DSO-28 with pins removed for improved clearance and creepage.

### **3.2 Motion Control Engine**

iMOTION™ IMI111T use the latest generation of the Motion Control Engine (MCE). The MCE is a ready-to-use solution for variable speed drives and contains all control functions to perform closed loop control of a three phase motor.

Multiple configurable protections like over- and under-voltage, over current or rotor lock are integrated protecting the power stage as well as the motor itself.

iMOTION™ IMI111T supports the use in applications requiring functional safety according to IEC/UL 60730-1 ('Class B')

Using the MCE does not require any software development. Instead the MCE is configured for the concrete power stage configuration and motor type using PC based tools. Following parameter creation the behavior of the motor control loop can be monitored and fine tuned in real time. The respective tools are available for download from the iMOTION™ web pages.

For improved application flexibility the MCE contains a scripting engine running user scripts in the background task. Writing, downloading and monitoring scripts is supported by the above mentioned tools.

The MCE is driven by an internal temperature compensated oscillator that supports peripheral operation at 96 MHz and data processing at 48 MHz.

This data sheet provides all electrical, mechanical, thermal and quality parameters of the IMI111T. A more detailed description of the features and functionality of the MCE can be found in the respective reference manual. The MCE software images are made available for download from the Infineon web site. A special secure boot algorithm assures that these MCE software images can only be installed onto the matching hardware derivative, i.e. the product variant for which the software has been tested for.

### **3 Functional description**

## **3.3 Gate driver function**

### **3.3.1 Features and protections**

The 3-phase high-voltage gate driver integrated in IMI111T is based on 600 V high-voltage junction isolation technology . It integrates a boot strap bootFET structure, so only external bootstrap capacitors are needed outside the module for bootstrap functionality. The driver output impedance is designed to meet an optimal dv/dt for EMI and switching loss trade offs. It is designed for 2 to 3 V/nsec at a rated current condition. The driver employs the anti-shoot-through protection, the integrated bootstrap function for high-side floating supplies, the low standby power and the under voltage lockout protection function for  $V_{CC}$  and high-side  $V_{BS}$  supplies. The under voltage lockout for  $V_{CC}$  is reported as latched fault at pin *RFE*, and the *RFE* pin is connected to *GK* pin of the controller.

3 Functional description

3.3.2 Block diagram

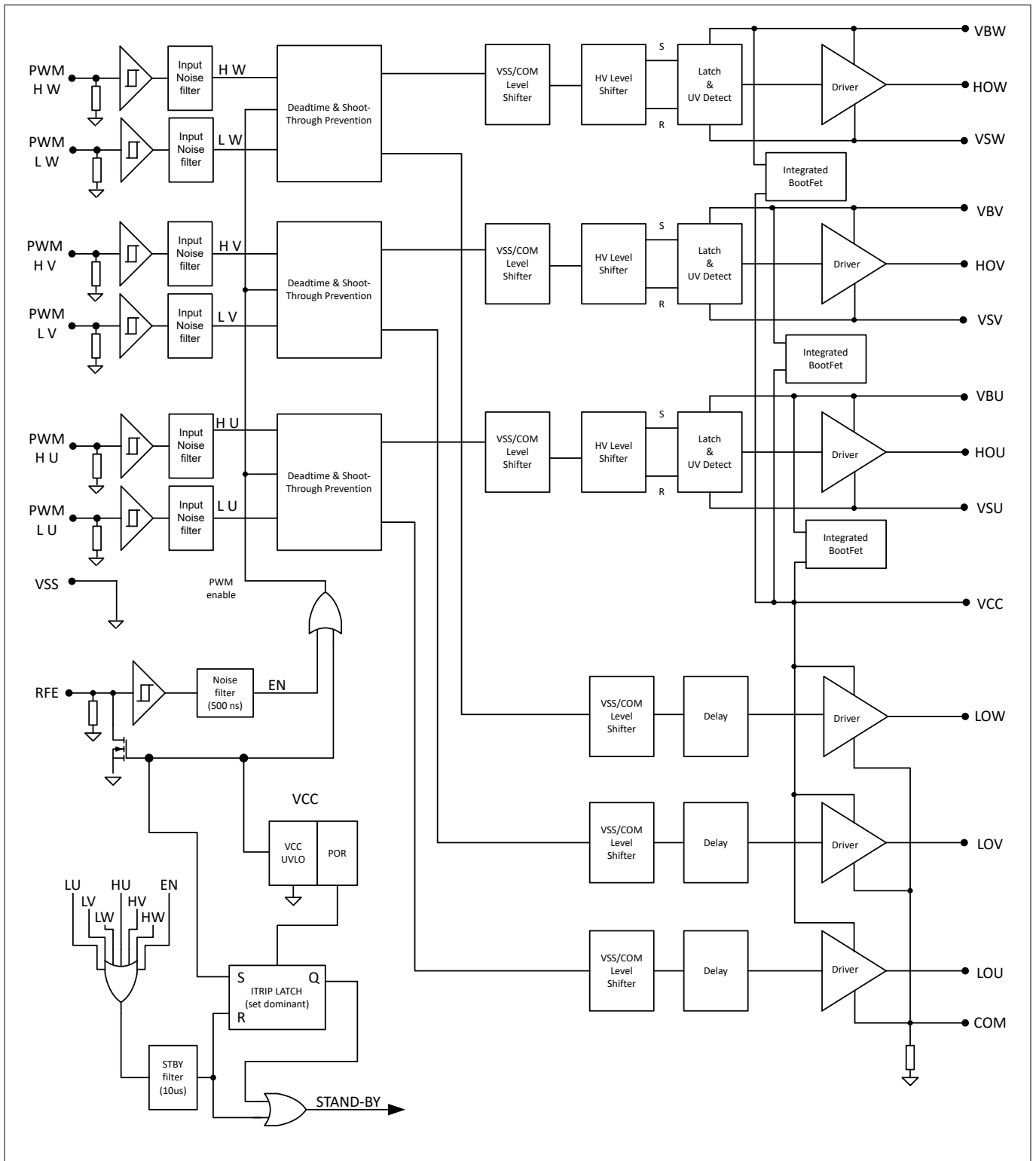
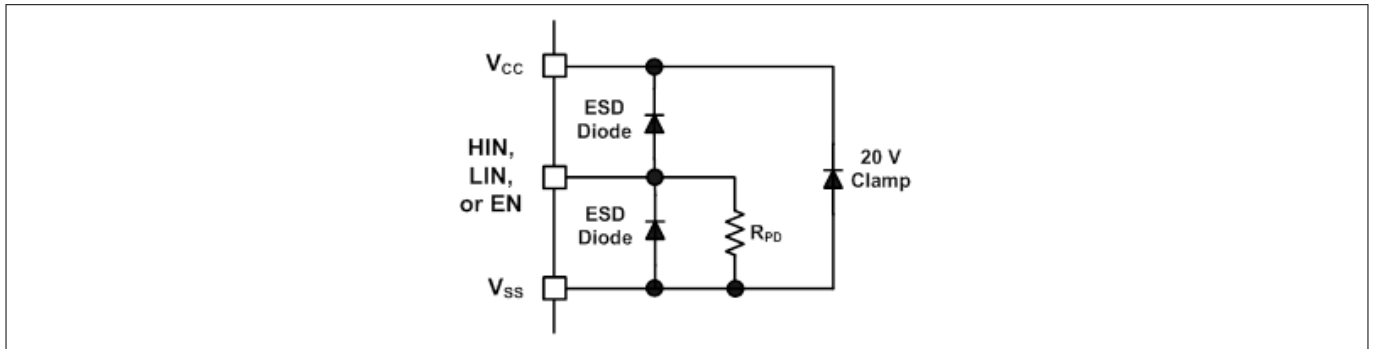

Figure 4 Block diagram of gate driver function

**3 Functional description**

**3.3.3 I/O structure**

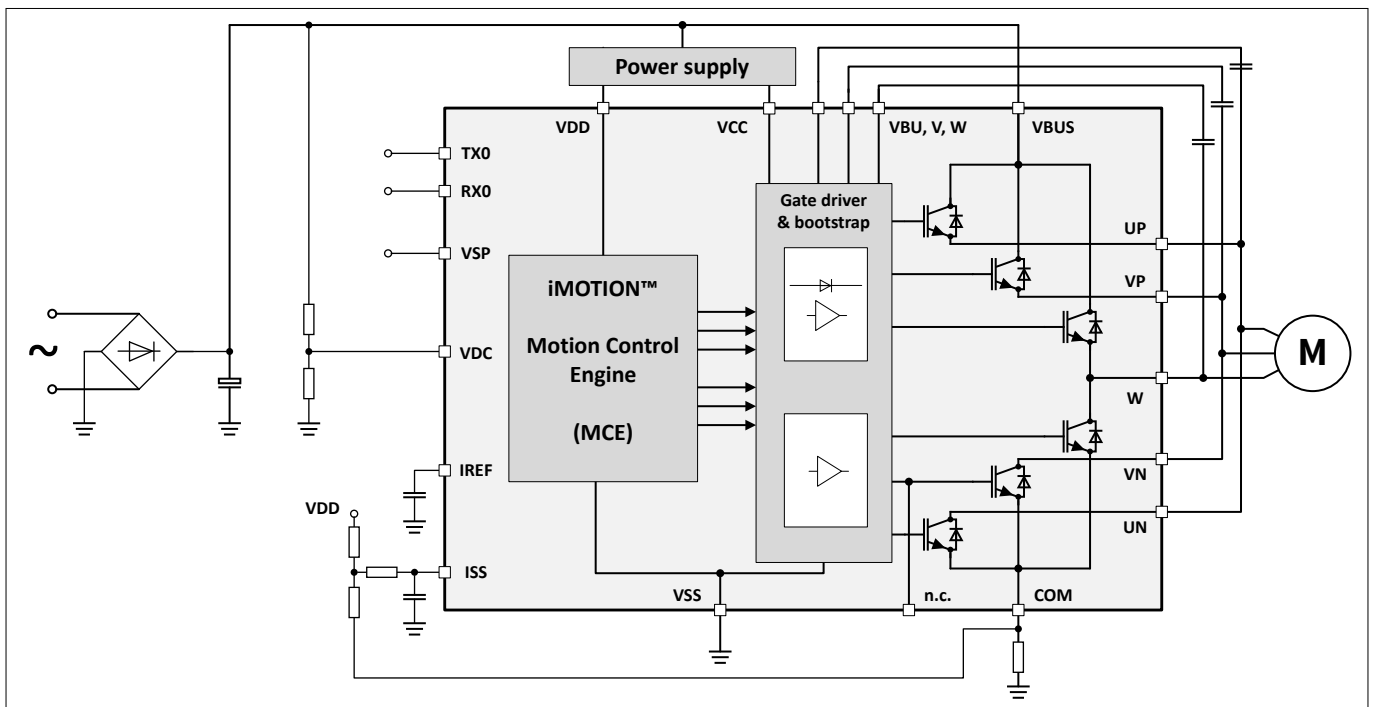

**Figure 5** VCC pin I/O gate driver structure

**3.4 IGBTs**

The six IGBTs have a monolithically integrated diode which makes this technology suited for consumer drives. They offers improvements of the performance, controllability and reliability including improved humidity robustness compared to previous generations. With low switching losses they provide adequate performance at a competitive price with good di/dt controllability in order to reduce electromagnetic noise.

**3.5 Application diagrams**



**Figure 6** Application block diagram using single shunt current sensing

**4 Electrical characteristics and parameters**

**4 Electrical characteristics and parameters**

**4.1 General parameters**

**4.1.1 Parameter Interpretation**

The parameters listed in this section represent partly the characteristics of the IMI111T and partly its requirements on the system. To aid interpreting the parameters easily when evaluating them for a design, they are indicated by the abbreviations in the “Symbol” column:

- **CC**  
Such parameters indicate **C**ontroller **C**haracteristics, which are distinctive feature of the IMI111T and must be regarded for a system design.
- **SR**  
Such parameters indicate **S**ystem **R**equirements, which must be provided by the application system in which the IMI111T is designed in.

**4.1.2 Absolute maximum ratings**

Stresses above the values listed under “Absolute Maximum Ratings” may cause permanent damage to the device. This is a stress rating only and functional operation of the device at these or any other conditions above those indicated in the operational sections of this specification is not implied. Exposure to absolute maximum rating conditions may affect device reliability.

**Table 2 Absolute maximum ratings**

Parameter	Symbol	Values		Unit	Note or Test Condition
		Min.	Max.		
Ambient temperature	$T_A$ SR	-40	105	°C	
Junction temperature	$T_J$ SR	-40	115	°C	Digital controller
		-40	150	°C	Gate driver, power transistors
Storage temperature	$T_{ST}$ SR	-40	125	°C	
Lead temperature (soldering, 30 seconds)	$T_L$ SR	---	260	°C	
Digital Controller voltage	$V_{DD}$ SR	-0.3	6	V	
Controller digital and analog pin voltage	$V_{ID}$ SR	-0.3	$V_{DD}+0.3$	V	
Input current on any controller pin during overload condition	$I_{IN}$ SR	-10	10	mA	
Absolute sum of all controller input currents during overload condition	$\Sigma I_{IN}$ SR	-50	50	mA	
Gate driver high-side floating rated voltage	$V_{B1,2,3}$ SR	-0.3	600	V	

**(table continues...)**

**4 Electrical characteristics and parameters**

**Table 2 (continued) Absolute maximum ratings**

Parameter	Symbol		Values		Unit	Note or Test Condition
			Min.	Max.		
Gate driver low-side supply voltage	$V_{CC\ SR}$		-0.3	20	V	
Collector-emitter voltage	$V_{CE}$		---	600	V	$T_{vj} \geq 25^\circ\text{C}$
DC collector current, limited by $T_{vjmax}$	$I_C$	-026H	---	2	A	$T_c = 25^\circ\text{C}$
		-046H	---	4	A	
Pulsed collector current, $t_p$ limited by $T_{vjmax}$	$I_{Cpuls}$	-026H	---	3	A	$T_c = 25^\circ\text{C}$
		-046H	---	5	A	
Short-circuit withstand time	$t_{SC}$			3	$\mu\text{s}$	$V_{CE} \leq 400\text{ V}$ , $V_{CC} = 15\text{ V}$ , Allowed number of short circuits < 1000, Time between short circuits $\geq 1.0\text{ s}$ , $T_{vj} = 150\text{ C}$
Repetitive peak reverse voltage	$V_{RRM}$		---	600	V	$T_{vj} \geq 25^\circ\text{C}$

Note: Characterized, not tested at manufacturing.

Note: Voltages referenced to  $V_{SS}$  if not stated otherwise

**4.1.3 Pin Reliability in Overload**

When receiving signals from higher voltage devices, low-voltage devices experience overload currents and voltages that go beyond their own IO power supplies specification.

The table below defines overload conditions that will not cause any negative reliability impact if all the following conditions are met:

- full operation life-time is not exceeded
- [Operating Conditions](#) are met for
  - pad supply levels ( $V_{DD}$ )
  - temperature

If a pin current is outside of the [Operating Conditions](#) but within the overload conditions, then the parameters of this pin as stated in the Operating Conditions can no longer be guaranteed. Operation is still possible in most cases but with relaxed parameters.

Note: An overload condition on one or more pins does not require a reset.

Note: A series resistor at the pin to limit the current to the maximum permitted overload current is sufficient to handle failure situations like short to battery.

4 Electrical characteristics and parameters

Table 3 Overload Parameters

Parameter	Symbol	Values			Unit	Note or Test Condition
		Min.	Typ.	Max.		
Input current on analog port pins during overload condition	$I_{OVA}$ SR	-3	-	3	mA	
Input current on any port pin during overload condition	$I_{OV}$ SR	-5	-	5	mA	
Absolute sum of all input currents during overload condition	$I_{OVS}$ SR	-	-	25	mA	

Figure 7 shows the path of the input currents during overload via the ESD protection structures. The diodes against  $V_{DD}$  and ground are a simplified representation of these ESD protection structures.

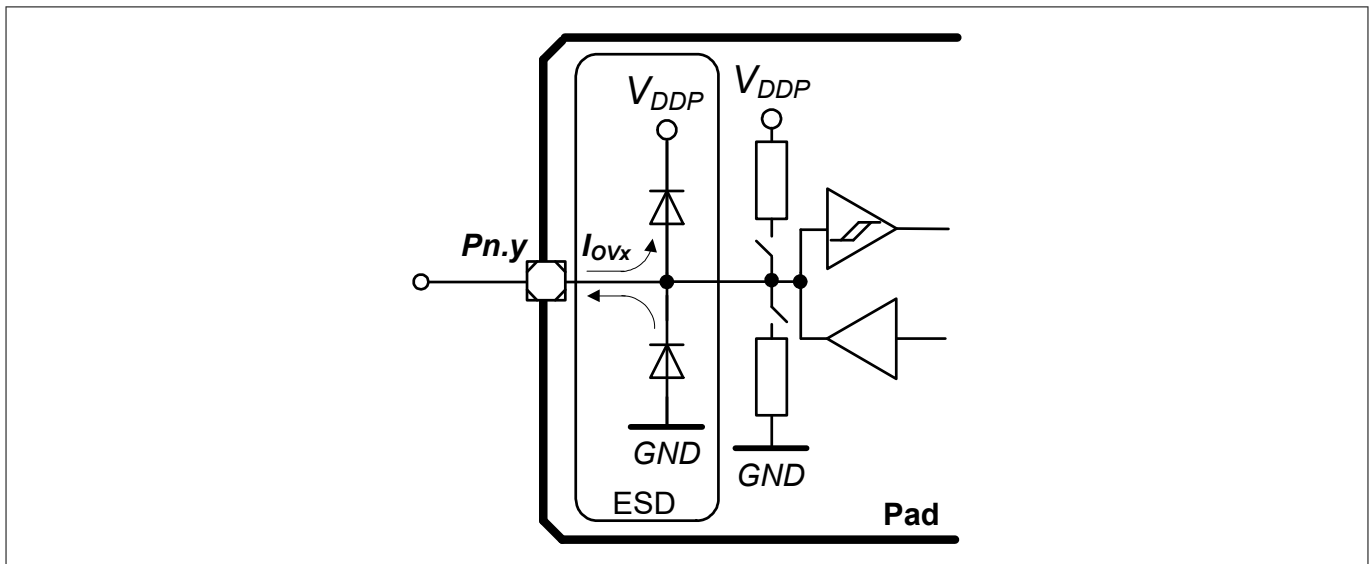

Figure 7 Input Overload Current via ESD structures

Table 4 and Table 5 list input voltages that can be reached under overload conditions. Note that the absolute maximum input voltages as defined in the Absolute maximum ratings must not be exceeded during overload.

Table 4 PN-Junction Characteristics for positive Overload

Pad Type	$I_{OV} = 5$ mA
Standard, High-current, AN/DIG_IN	$V_{IN} = V_{DD} + (0.3 \dots 0.5) \text{ V}$ $V_{AIN} = V_{DD} + 0.5 \text{ V}$ $V_{AREF} = V_{DD} + 0.5 \text{ V}$

Table 5 PN-Junction Characteristics for negative Overload

Pad Type	$I_{OV} = 5$ mA
Standard, High-current, AN/DIG_IN	$V_{IN} = V_{SS} - (0.3 \dots 0.5) \text{ V}$ $V_{AIN} = V_{SS} - 0.5 \text{ V}$ $V_{AREF} = V_{SS} - 0.5 \text{ V}$

**4 Electrical characteristics and parameters**

**4.1.4 Operating Conditions**

The following operating conditions must not be exceeded in order to ensure correct operation and reliability of the IMI111T. All parameters specified in the following tables refer to these operating conditions, unless noted otherwise.

**Table 6 Recommended Operating Conditions**

Parameter	Symbol	Values			Unit	Note or Test Condition
		Min.	Typ.	Max.		
Positive DC Bus Input Voltage	$V_{BUS}$ SR	-	-	480	V	
Gate Driver High Side Floating Supply Voltage	$V_{B1,2,3}$ SR	$V_S + 12.5$	-	$V_S + 17.5$	V	
Gate Driver Low Side Supply Voltage	$V_{CC}$ SR	13.5	-	16.5	V	
Digital supply voltage <sup>2)</sup>	$V_{DD}$ SR	3.0	3.3	5.5	V	

**4.2 DC characteristics**

**4.2.1 Input/Output Characteristics**

The table below provides the characteristics of the input/output pins of the controller.

*Note:* These parameters are not subject to production test, but verified by design and/or characterization.

*Note:* Unless otherwise stated, input DC and AC characteristics, including peripheral timings, assume that the input pads operate with the standard hysteresis.

**Table 7 Input/Output Characteristics (Operating Conditions apply)**

Parameter	Symbol		Limit Values		Unit	Test Conditions
			Min.	Max.		
Input low voltage on port pins (Standard Hysteresis)	$V_{ILPS}$	SR	-	$0.19 \times V_{DD}$	V	CMOS Mode
Input high voltage on port pins (Standard Hysteresis)	$V_{IHPS}$	SR	$0.7 \times V_{DD}$	-	V	CMOS Mode
Input low voltage on port pins (Large Hysteresis, scripting pins only)	$V_{ILPL}$	SR	-	$0.08 \times V_{DD}$	V	CMOS Mode
Input high voltage on port pins (Large Hysteresis, scripting pins only)	$V_{IHPL}$	SR	$0.85 \times V_{DD}$	-	V	CMOS Mode
Output low voltage on port pins	$V_{OLP}$	CC	-	1.0	V	$I_{OL} = 11 \text{ mA ( V)}$ $I_{OL} = 7 \text{ mA (3.3 V)}$

**(table continues...)**

<sup>2</sup> All supply pins must be driven with the same voltage.



**4 Electrical characteristics and parameters**

**Table 7 (continued) Input/Output Characteristics (Operating Conditions apply)**

Parameter	Symbol		Limit Values		Unit	Test Conditions
			Min.	Max.		
			-	0.4	V	$I_{OL} = 5 \text{ mA (5 V)}$ $I_{OL} = 3.5 \text{ mA (3.3 V)}$
Output high voltage on port pins	$V_{OHP}$	CC	$V_{DD} - 1.0$	-	V	$I_{OH} = -10 \text{ mA (5 V)}$ $I_{OH} = -7 \text{ mA (3.3 V)}$
			$V_{DD} - 0.4$	-	V	$I_{OH} = -4.5 \text{ mA (5 V)}$ $I_{OH} = -2.5 \text{ mA (3.3 V)}$
Rise/fall time on standard pad	$t_R, t_F$	CC	-	12	ns	50 pF @ 5 V
			-	15	ns	50 pF @ 3.3 V.
Pin capacitance (digital inputs/outputs)	$C_{IO}$	CC	-	10	pF	
Pull-up/-down resistor on port pins (if enabled in software)	$R_{PUP}$	CC	20	50	kΩ	$V_{IN} = V_{SS}$
Input leakage current <sup>3)</sup>	$I_{OZP}$	CC	-1	1	μA	$0 < V_{IN} < V_{DD}$ , $T_A 105^\circ\text{C}$
Maximum current per pin standard pin	$I_{MP}$	SR	-10	11	mA	-
Maximum current into $V_{DD}$ / out of $V_{SS}$	$I_{MVDD} /$ $I_{MVSS}$	SR	-	260	mA	

<sup>3</sup> An additional error current ( $I_{INJ}$ ) will flow if an overload current flows through an adjacent pin.

**4 Electrical characteristics and parameters**

**4.2.2 Analog to Digital Converter (ADC)**

The following table shows the Analog to Digital Converter (ADC) characteristics. This specification applies to all analog input including the analog Hall sensor interface input (AHALLx+/AHALLx-, where x=1,2) as given in the pin configuration list.

*Note: These parameters are not subject to production test, but verified by design and/or characterization.*

**Table 8 ADC Characteristics (Operating Conditions apply)<sup>4)</sup>**

Parameter	Symbol	Values			Unit	Note or Test Condition
		Min.	Typ.	Max.		
Supply voltage range	V <sub>DD</sub> SR	3.0	–	5.5	V	
Analog input voltage range	V <sub>AIN</sub> SR	V <sub>SS</sub> - 0.05	–	V <sub>DD</sub> + 0.05	V	
Conversion time	t <sub>C12</sub> CC	–	1.0	–	μs	Defined by SW
Total capacitance of an analog input	C <sub>AIN</sub> CC	–	–	10	pF	
Total capacitance of the reference input	C <sub>AREFT</sub> CC	–	–	10	pF	
Sample time	t <sub>sample</sub> CC	–	333	–	ns	Defined by SW
RMS noise	EN <sub>RMS</sub> CC	–	1.5	–	LSB12	
DNL error	EA <sub>DNL</sub> CC	–	±2.0	–	LSB12	
INL error	EA <sub>INL</sub> CC	–	±4.0	–	LSB12	
Gain error	EA <sub>GAIN</sub> CC	–	±0.5	–	%	
Offset error	EA <sub>OFF</sub> CC	–	±8.0	–	mV	

**4.2.3 Analog comparator characteristics**

The table below shows the Analog Comparator characteristics.

*Note: These parameters are not subject to production test, but verified by design and/or characterization.*

**Table 9 Analog Comparator Characteristics (Operating Conditions apply)**

Parameter	Symbol		Values			Unit	Note or Test Conditions
			Min.	Typ.	Max.		
Input Voltage	V <sub>CMP</sub>	SR	-0.05	–	V <sub>DDP</sub> + 0.05	V	includes common mode and differential input voltages
Input Offset	V <sub>CMPOFF</sub>	CC	–	+/-3	–	mV	High power mode ΔV <sub>CMP</sub> < 200 mV
Input Hysteresis	V <sub>HYS</sub>	CC	–	+/-15	–	mV	Defined by SW

<sup>4</sup> All parameters are defined for the full supply range if not stated otherwise.

**4 Electrical characteristics and parameters**

**4.2.4 Power Supply Current Controller**

The total power supply current defined below consists of a leakage and a switching component for the controller through the  $V_{DD}$  pin. The  $V_{CC}$  supply current is listed under the gate driver parameters.

Application relevant values are typically lower than those given in the following tables, and depend on the customer's system operating conditions (e.g. thermal connection or used application configurations).

*Note: These parameters are not subject to production test, but verified by design and/or characterization.*

**Table 10 Power supply parameter table  $V_{DD}= 5.0V$**

Parameter	Symbol	Values			Unit	Note or Test Condition
		Min.	Typ.	Max.		
Active mode current motor control only	$I_{DD1\ CC}$	–	10	20	mA	$T_a = 25^\circ C$

**4.2.5 Flash Memory Parameters**

*Note: These parameters are not subject to production test, but verified by design and/or characterization.*

**Table 11 Flash Memory Parameters**

Parameter	Symbol	Values			Unit	Note or Test Condition
		Min.	Typ.	Max.		
Data Retention Time	$t_{RET\ CC}$	10			years	Max. 100 erase / program cycles
Erase Cycles	$N_{ECCY\ CC}$			$5 \cdot 10^4$	cycles	Sum of page and sector erase cycles a page sees
Total Erase Cycles	$N_{TECCY\ CC}$			$2 \cdot 10^6$	cycles	

**4 Electrical characteristics and parameters**

**4.2.6 Under voltage lockout DC characteristics**

Note: These parameters are not subject to production test, but verified by design and/or characterization.

**Table 12 Under voltage lockout DC characteristics**

$T_A = 25^\circ\text{C}$ , all voltage parameters are referenced to  $V_{SS}$  unless specified otherwise.

Parameter	Symbol	Values			Unit	Note or condition
		Min.	Typ.	Max.		
$V_{DD}$ brownout reset voltage	$V_{DDPBO}$	1.55	1.62	1.75	V	
$V_{DD}$ voltage to ensure defined pad states	$V_{DDPA}$	---	1.0	---	V	
Start-up time from power-on reset	$t_{SSW}$	---	260	---	$\mu\text{s}$	
BMI program time	$t_{BMI}$	---	8.25	---	ms	
$V_{CC}$ and $V_{BS}$ supply undervoltage positive going threshold - gate driver	$V_{CCUV+}$ $V_{BSUV+}$	10.6	11.1	11.6	V	
$V_{CC}$ and $V_{BS}$ supply undervoltage negative going threshold - gate driver	$V_{CCUV-}$ $V_{BSUV-}$	10.4	10.9	11.4	V	
$V_{CC}$ and $V_{BS}$ supply under voltage hysteresis – gate driver	$V_{CCUVH}$ $V_{BSUVH}$	---	0.2	---	V	

#### 4 Electrical characteristics and parameters

#### 4.2.7 Power Supply Current Gate Driver

The  $V_{CC}$  quiescent supply current and standby current consumptions are listed under the table.

Note: These parameters are not subject to production test, but verified by design and/or characterization.

**Table 13 Power supply parameter table;  $V_{CC}=V_{BS}=15.0V$**

Parameter	Symbol	Values			Unit	Note or Test Condition
		Min.	Typ.	Max.		
Quiescent $V_{BS}$ supply current	$I_{QBS\ CC}$	–	70	120	uA	$T_a = 25^\circ C$
Quiescent $V_{CC}$ supply current	$I_{QCC\ CC}$	–	3	3.5	mA	$T_a = 25^\circ C$
Standby current consumption	$I_{STBY\ CC}$	–	200	500	mA	$T_a = 25^\circ C$

#### 4.2.8 IGBT

**Table 14 Characteristic values**

Parameter	Symbol		Values			Unit	Note or test condition
			Min.	Typ.	Max.		
Collector-emitter saturation voltage	$V_{CESat}$	-026H		1.5		V	0.5A, $T_J=25^\circ C$
				1.6		V	0.5A, $T_J=150^\circ C$
	-046H		1.4		V	1.0A, $T_J=25^\circ C$	
			1.5		V	1.0A, $T_J=150^\circ C$	
Collector-emitter leakage current	$I_{CES}$	-026H		1		$\mu A$	$V_{IN}=0V, V_{BUS}=600V, T_J=25^\circ C$
				5		$\mu A$	$V_{IN}=0V, V_{BUS}=600V, T_J=150^\circ C$
	-046H		0.9		$\mu A$	$V_{IN}=0V, V_{BUS}=600V, T_J=25^\circ C$	
			8		$\mu A$	$V_{IN}=0V, V_{BUS}=600V, T_J=150^\circ C$	

Note: Electrical Characteristic, at  $T_{vj} = 25^\circ C$ , unless otherwise specified

#### 4.2.9 Diode

**Table 15 Characteristic values**

Parameter	Symbol		Values			Unit	Note or test condition
			Min.	Typ.	Max.		
Diode forward voltage	$V_F$	-026H		1.6		V	0.5A, $T_J=25^\circ C$
				1.5		V	0.5A, $T_J=150^\circ C$
	-046H		1.5		V	1.0A, $T_J=25^\circ C$	
			1.34		V	1.0A, $T_J=150^\circ C$	

#### **4 Electrical characteristics and parameters**

*Note: Electrical Characteristic, at  $T_{vj} = 25^{\circ}\text{C}$ , unless otherwise specified.*

4 Electrical characteristics and parameters

4.3 AC characteristics

4.3.1 Testing Waveforms

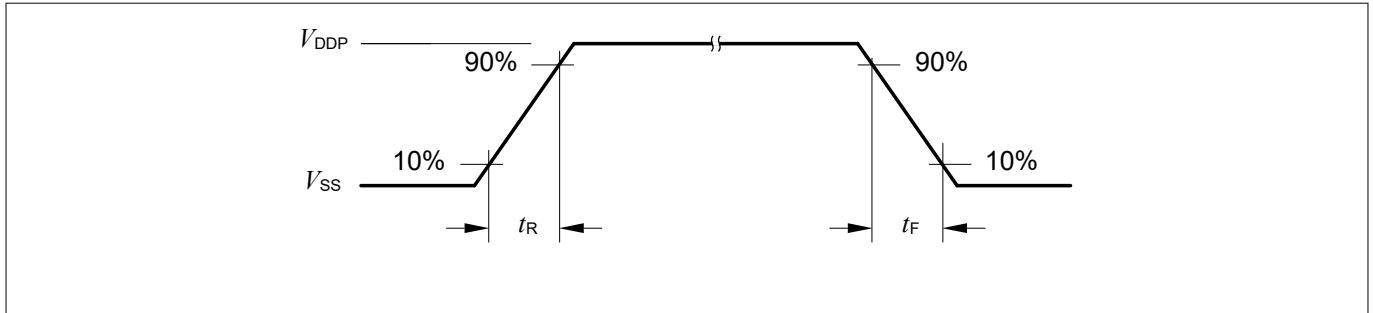

Figure 8 Rise/Fall Time Parameters

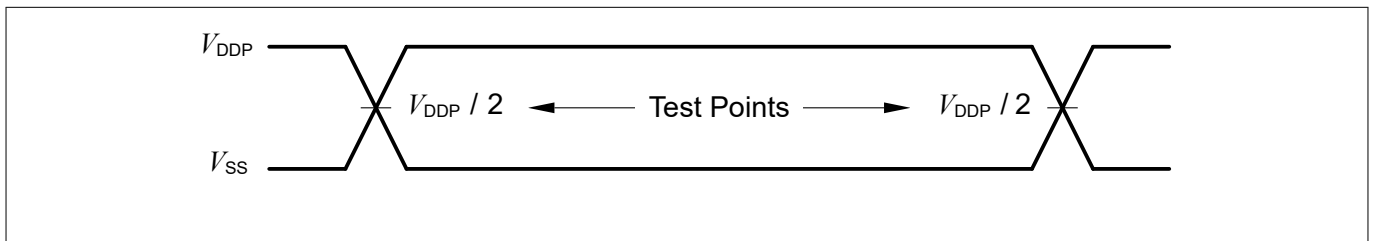

Figure 9 Testing Waveform, Output Delay

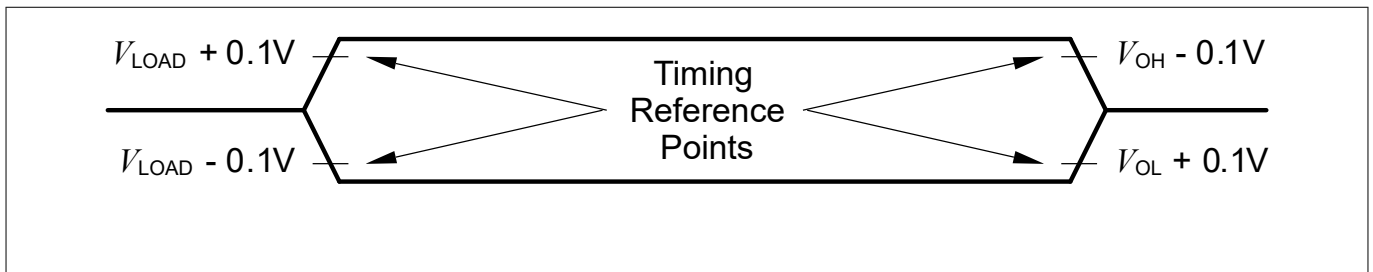

Figure 10 Testing Waveform, Output High Impedance

4.3.2 Power-Up and Supply Threshold Characteristics

This chapter provides the characteristics of the supply threshold for the controller.

The guard band between the lowest valid operating voltage and the brownout reset threshold provides a margin for noise immunity and hysteresis. The electrical parameters may be violated while  $V_{DD}$  is outside its operating range.

The brownout detection triggers a reset within the defined range. The prewarning detection can be used to trigger an early warning and issue corrective and/or fail-safe actions in case of a critical supply voltage drop.

*Note:* These parameters are not subject to production test, but verified by design and/or characterization.

*Note:* Operating Conditions apply.

**4 Electrical characteristics and parameters**

**Table 16 Power-Up and Supply Threshold Parameters**

Parameter	Symbol	Values			Unit	Note or Test Condition
		Min.	Typ.	Max.		
$V_{DD}$ ramp-up time	$t_{RAMPUP}$ SR	$V_{DD}/S_{VDDrise}$	–	$10^7$	$\mu s$	
$V_{DD}$ slew rate	$S_{VDDOP}$ SR	0	–	0.1	$V/\mu s$	Slope during normal operation
	$S_{VDD10}$ SR	0	–	10	$V/\mu s$	Slope during fast transient within +/-10% of $V_{DD}$
	$S_{VDDrise}$ SR	0	–	10	$V/\mu s$	Slope during power-on or restart after brownout event
	$S_{VDDfall}$ <sup>5)</sup> SR	0	–	0.25	$V/\mu s$	Slope during supply falling out of the +/-10% limits <sup>6)</sup>
$V_{DD}$ prewarning voltage	$V_{DDPW}$ CC	2.1	2.25	2.4	V	ANAVDEL.VDEL_SELECT = 00 <sub>B</sub>
		2.85	3	3.15	V	ANAVDEL.VDEL_SELECT = 01 <sub>B</sub>
		4.2	4.4	4.6	V	ANAVDEL.VDEL_SELECT = 10 <sub>B</sub>
$V_{DD}$ brownout reset voltage	$V_{DDBO}$ CC	1.55	1.62	1.75	V	calibrated, before user code starts running
$V_{DD}$ voltage to ensure defined pad states	$V_{DDA}$ CC	–	1.0	–	V	
Start-up time from power-on reset	$t_{SSW}$ CC	–	260	–	$\mu s$	Time to the first user code instruction <sup>7)</sup>
Start-up time to PWM on	$t_{PWMON}$ CC	5.2	–	360	ms	Time to PWM enabled

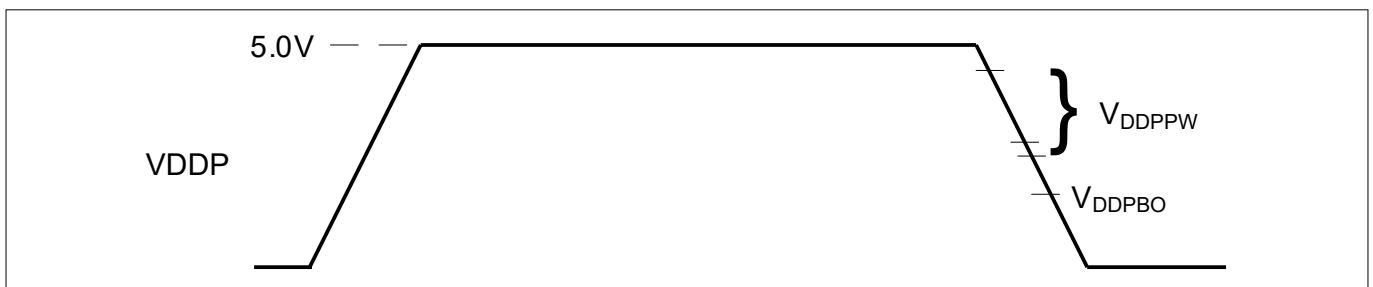

**Figure 11 Supply Threshold Parameters**

<sup>5</sup> A capacitor of at least 100 nF has to be added between VDD and VSS to fulfill the requirement as stated for this parameter.  
<sup>6</sup> Valid for a 100 nF buffer capacitor connected to supply pin where current from capacitor is forwarded only to the chip. A larger capacitor value has to be chosen if the power source sink a current.  
<sup>7</sup> This values does not include the ramp-up time. During startup firmware execution, MCLK is running at 48 MHz and the clocks to peripheral as specified in register CGATSTAT0 are gated.



## 4 Electrical characteristics and parameters

### 4.3.3 On-Chip Oscillator Characteristics

Table 17 provides the characteristics of the 96 MHz digital controlled oscillator DCO1. The DCO1 is used as the time base during normal operation.

Note: These parameters are not subject to production test, but verified by design and/or characterization.

**Table 17 96 MHz DCO1 Characteristics**

Parameter	Symbol	Limit Values			Unit	Test Conditions
		Min.	Typ.	Max.		
Nominal frequency	$f_{\text{NOM CC}}$	-	96	-	MHz	under nominal conditions after trimming
Accuracy with adjustment algorithm <sup>8)</sup> based on temperature sensor	$\Delta f_{\text{LTTS CC}}$	-0.6	-	+0.6	%	with respect to $f_{\text{NOM}}(\text{typ})$ , $T_A$ from 0°C to 105°C
		-1.9	-	+1.0	%	with respect to $f_{\text{NOM}}(\text{typ})$ , $T_A$ from -25°C to 105°C
		-2.6	-	+1.3	%	with respect to $f_{\text{NOM}}(\text{typ})$ , $T_A$ from -40°C to 105°C
Accuracy	$\Delta f_{\text{LT CC}}$	-1.7	-	+3.4	%	with respect to $f_{\text{NOM}}(\text{typ})$ , $T_A$ from 0°C to 85°C
		-3.9	-	+4.0	%	with respect to $f_{\text{NOM}}(\text{typ})$ , $T_A$ from -40°C to 105°C

Table 18 provides the characteristics of the 32 kHz digital controlled oscillator used internally as a secondary clock source for the internal watchdog.

**Table 18 32 kHz DCO2 Characteristics**

Parameter	Symbol	Limit Values			Unit	Test Conditions
		Min.	Typ.	Max.		
Nominal frequency	$f_{\text{NOM CC}}$	-	32.75	-	kHz	under nominal conditions <sup>9)</sup> after trimming
Accuracy	$\Delta f_{\text{LT CC}}$	-1.7	-	+3.4	%	with respect to $f_{\text{NOM}}(\text{typ})$ , $T_A$ from 0°C to 85°C
		-3.9	-	+4.0	%	with respect to $f_{\text{NOM}}(\text{typ})$ , $T_A$ from -40°C to 105°C

### 4.3.4 IGBT

The characteristics given below have been measured under the following condition if not stated otherwise:

$V_{\text{CC}} - V_{\text{SS}} = 15\text{V}$ ,  $V_{\text{B}} - V_{\text{S}} = 15\text{V}$ ,  $V_{\text{BUS}} = 300\text{V}$ ,  $I_{\text{C}} = 0.5\text{A}$  for IMI111T-026H and  $I_{\text{C}} = 1\text{A}$  for IMI111T-046H,  $L = 84\text{mH}$

<sup>8)</sup> MCE version newer or equal to V1.03.00, clock adjustment algorithm for improved accuracy enabled

<sup>9)</sup> The deviation is relative to the factory trimmed frequency at nominal  $V_{\text{DCC}}$  and  $T_A = +25^\circ\text{C}$ .

**4 Electrical characteristics and parameters**

**Table 19 Characteristic values**

Parameter	Symbol		Values			Unit	Note or test condition
			Min.	Typ.	Max.		
Turn-on switching energy	$E_{ON}$	-026H		23		μJ	$T_J=25^{\circ}C$
				40.2		μJ	$T_J=150^{\circ}C$
	-046H		32		μJ	$T_J=25^{\circ}C$	
			60		μJ	$T_J=150^{\circ}C$	
Turn-off switching energy	$E_{OFF}$	-026H		7.6		μJ	$T_J=25^{\circ}C$
				11.4		μJ	$T_J=150^{\circ}C$
	-046H		16.8		μJ	$T_J=25^{\circ}C$	
			25.5		μJ	$T_J=150^{\circ}C$	

Note: Electrical Characteristic, at  $T_{vj} = 25^{\circ}C$ , unless otherwise specified

**4.3.5 Diode**

The characteristics given below have been measured under the following condition if not stated otherwise:

$V_{CC}-V_{SS}=15V$ ,  $V_B-V_S=15V$ ,  $V_{BUS}=300V$ ,  $I_C = 0.5A$  for IMI111T-026H and  $I_C = 1A$  for IMI111T-046H,  $L=84mH$

**Table 20 Characteristic values**

Parameter	Symbol		Values			Unit	Note or test condition
			Min.	Typ.	Max.		
Diode reverse recovery energy	$E_{REC}$	-026H		5.9		μJ	$T_J=25^{\circ}C$
				10.1		μJ	$T_J=150^{\circ}C$
	-046H		13.2		μJ	$T_J=25^{\circ}C$	
			25.2		μJ	$T_J=150^{\circ}C$	

Note: Electrical Characteristic, at  $T_{vj} = 25^{\circ}C$ , unless otherwise specified

## 4 Electrical characteristics and parameters

### 4.4 Motor Control Parameters

The following values are given for reference only. Concrete parameters are defined in the iMOTION™ Motion Control Engine (MCE) software.

#### 4.4.1 PWM Characteristics

**Table 21** Electrical characteristics

Parameter	Symbol	Values			Unit	Note or test condition
		Min.	Typ.	Max.		
Motor PWM Frequency <sup>10)</sup>	f <sub>PWM</sub>	5	16	24	kHz	

#### 4.4.2 Current Sensing

**Table 22** Motor Current Sensing

Parameter	Symbol	Values			Unit	Note or test condition
		Min.	Typ.	Max.		
Input range	I <sub>PWM</sub>	V <sub>SS</sub> -0.05	-	V <sub>DD</sub> +0.05	V	
Configurable analog gain		-	1/ 3/ 6/ 12	-		
Itrip input range	I <sub>PWMTRIP</sub>	V <sub>SS</sub> -0.05	-	V <sub>DD</sub> +0.05	V	
Itrip offset		-	±8	-	mV	
Input capacitance	C <sub>REF</sub>	-	-	10	pF	REFU, REFV, REFW capacitor

<sup>10)</sup> Actual min. and max. limits defined in resp. software version

4 Electrical characteristics and parameters

4.4.3 Fault Timing

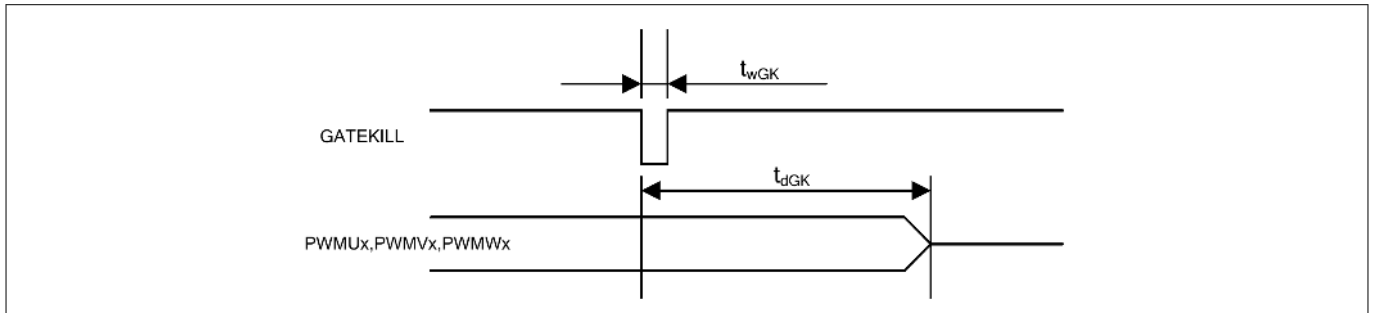

Figure 12 Fault timing

Table 23 Gatekill timing

Parameter	Symbol	Values			Unit	Note or test condition
		Min.	Typ.	Max.		
GK pulse width	$t_{wGK}$	1	-	-	$\mu\text{s}$	
GK input to PWM shutoff	$t_{dGK}$	-	1.3	-	$\mu\text{s}$	
Motor Fault reset timing	$t_{\text{RESET}}$	-	1.84	-	ms	fault reset command via UART to PWM reactivation
MCE digital ITRIP filter window	$t_{\text{PWMOFF}}$	0.075	1.0	10	$\mu\text{s}$	Configurable in software

Note: The ITRIP filter window must be configured according to the rated short circuit withstand time of the respective power stage taking into consideration any delay in external circuitry. For iMOTION™ devices with integrated power stage the value is specified in the Absolute maximum ratings of the device.

**4 Electrical characteristics and parameters**

**4.5 Device Interfaces**

iMOTION™ devices provide several interfaces to either control the motor drive in the application or report back its status. The availability of a specific interface depends upon the concrete device chosen as well as the version of the Motion Control Engine (MCE) applied. The following sections and tables specify these interfaces as well as the respective limits. The configuration settings for these interfaces are described in the MCE Reference Manual.

*Note: These parameters are not subject to production test, but verified by design and/or characterization. Operating conditions apply.*

**4.5.1 UART Interface**

The UART interface is configured as given below.

**Table 24 Electrical characteristics**

Parameter	Symbol	Values			Unit	Note or test condition
		Min.	Typ.	Max.		
UART baud rate		1200	57600	-	Bps	
UART mode		-	8-N-1	-		data-parity-stop bit
UART sampling filter period <sup>11)</sup>	$T_{UARTFIL}$	-	1/16	-	$T_{BAUD}$	

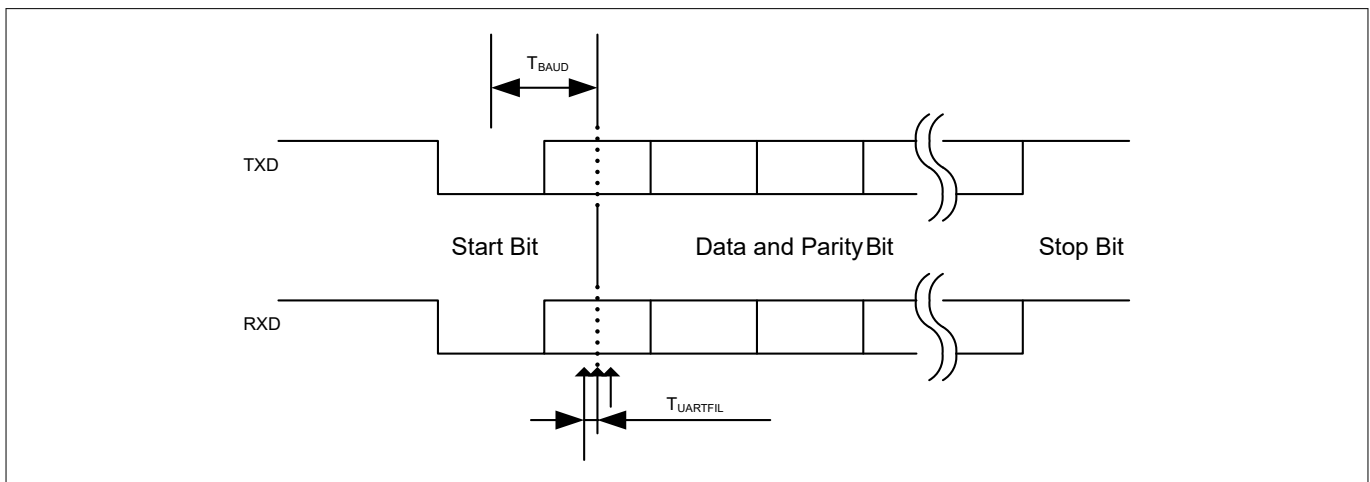

**Figure 13 UART timing**

<sup>11</sup> Each bit including start and stop bit is sampled three times at center of a bit at an interval of  $1/16 T_{BAUD}$ . If three sampled values do not agree, then UART noise error is generated.

4 Electrical characteristics and parameters

4.5.2 Analog Speed Input

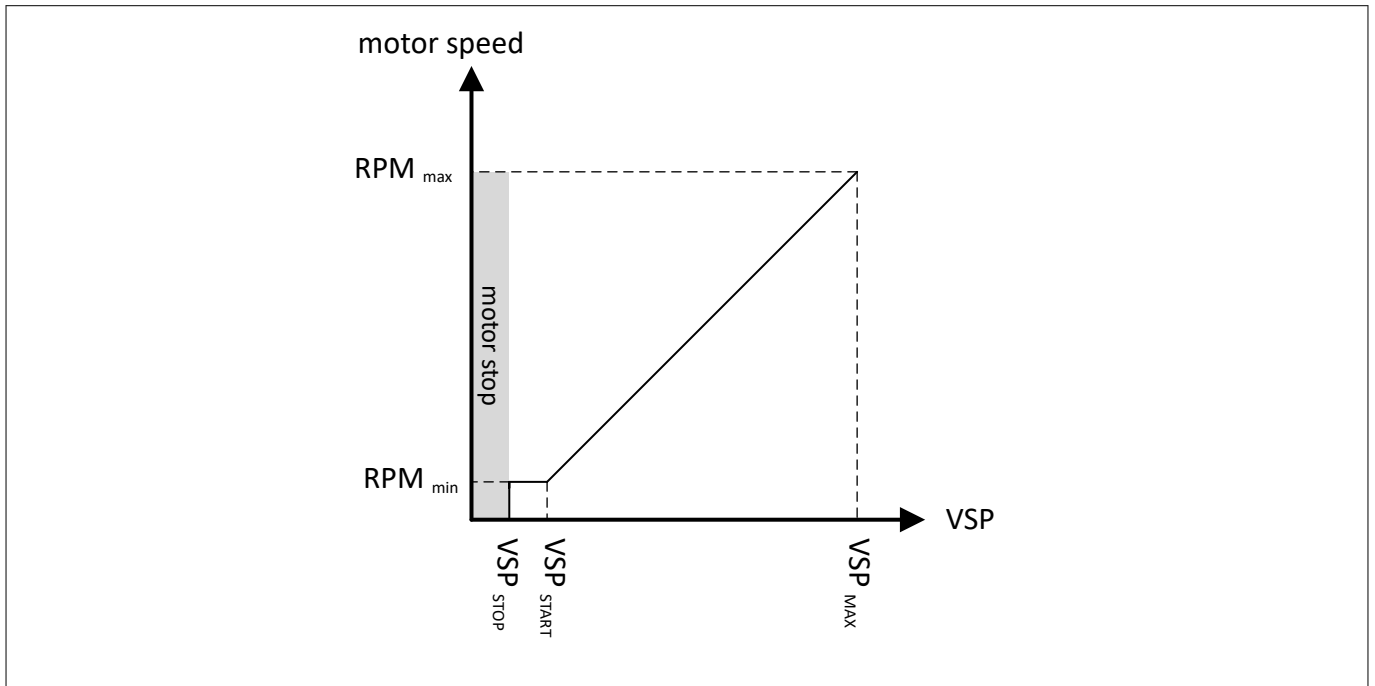

Figure 14 VSP analog control mode

Table 25 Analog Speed Control Voltage (VSP)

Parameter	Symbol	Values			Unit	Note or test condition
		Min.	Typ.	Max.		
Motor start voltage	$VSP_{START}$	-	1.2	-	V	Configured $VSP_{START}=1.0V$
Motor stop voltage	$VSP_{STOP}$	-	1.0	-	V	Configured $VSP_{STOP}=1.0V$
Motor max voltage	$VSP_{MAX}$	-	4.9	4.95	V	$V_{DD}=5.0V$
VSP active to PWM start	$t_{START}$	-	44	-	ms	
VSP inactive to PWM stop	$t_{STOP}$	-	16	-	ms	

**5 Device and package specifications**

**5 Device and package specifications**

**5.1 Quality declaration**

**Table 26 Quality Parameters**

Parameter	Symbol		Limit Values		Unit	Notes
			Min.	Max.		
ESD susceptibility according to Human Body Model (HBM)	$V_{HBM}$ SR	-026H	–	1500	V	ANSI/ESDA/JEDEC-JS-001
		-046H	–	2500	V	
ESD susceptibility according to Charged Device Model (CDM) pins	$V_{CDM}$ SR		–	750	V	ANSI/ESDA/JEDEC-JS-002
Moisture sensitivity level	MSL CC		–	3	–	JEDEC J-STD-020D
Soldering temperature	$T_{SDR}$ SR		–	260	°C	JEDEC J-STD-020D

**5.2 SBSL and Chip-IDs**

The table below gives the IDs for the individual devices in the IMI111T family. Depending upon the mode either the SBSL-ID (secure boot loader) or the Chip-ID should be used to identify the device. For details refer to the Reference Manual or the iMOTION™ Programming Manual.

**Table 27 SBSL-IDs and Chip-IDs**

Product Type	Package	Chip-ID	SBSL-ID
IMI111T-026H	DSO-22	0x41110263	02b53535c9200258d4e2e31cd3dc6ece
IMI111T-046H	DSO-22	0x41110463	02eebe97d58ed38f2f3e46a0e963cf0b

**5.3 Thermal characteristics**

*Note: The case to ambient thermal resistance is measured based on the evaluation board EVAL-IMI111T using a FR4 2-layer PCB board with device mounted and power evenly distributed to six IGBTs.*

**Table 28 Thermal characteristics**

Parameter	Symbol		Values			Unit	Note or test condition
			Min.	Typ.	Max.		
Total thermal resistance, case to ambient	$R_{th(C-A)}$	-026H		31		°C/W	
		-046H		30		°C/W	
Single IGBT thermal resistance, junction to case	$R_{th(J-C)}$	-026H		53		°C/W	
		-046H		47		°C/W	

*Note: Characterized, not tested at manufacturing.*

**5 Device and package specifications**

**5.4 Typical performance**

The following performance curves have been measured on the respective evaluation boards in free air without any heat sink. For more detailed values as well as the specification and layout of the pcb used please refer to the documentation of the evaluation board.

*Note: Data shown is typical and should not be used as specification limits.*

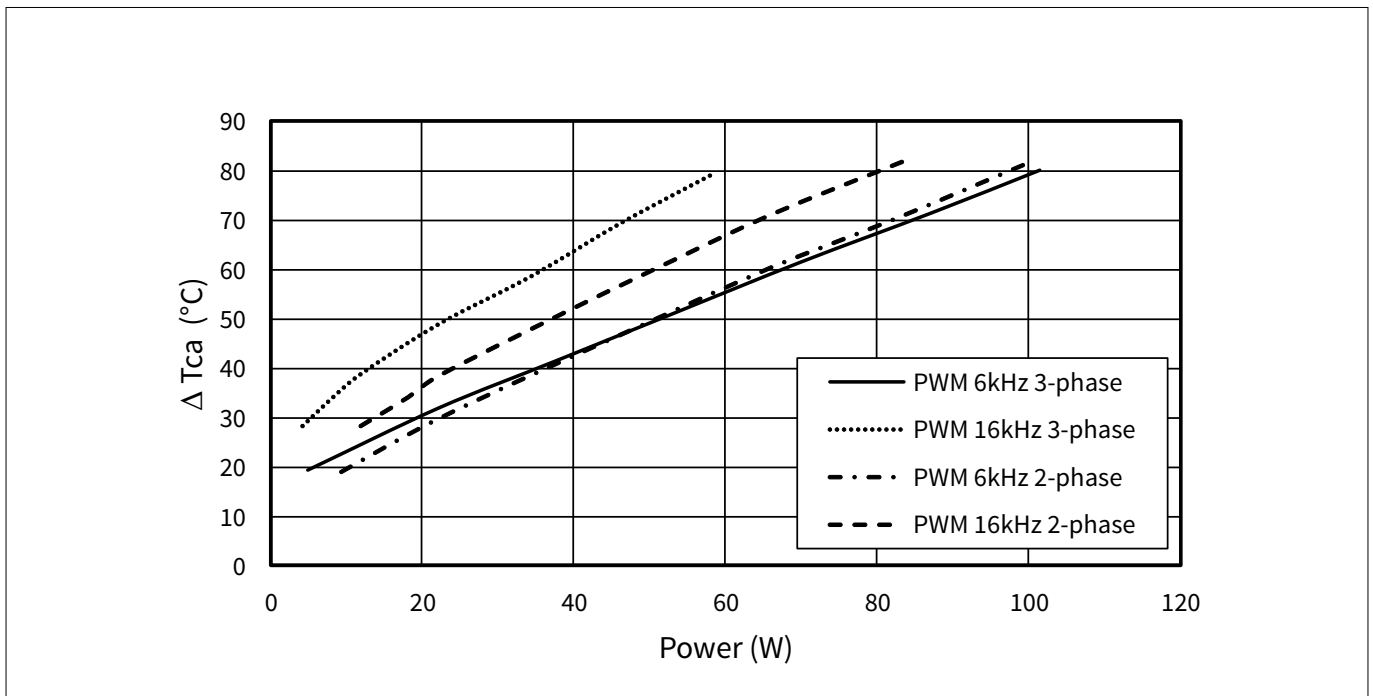

**Figure 15 Typical performance IMI111T-026H**

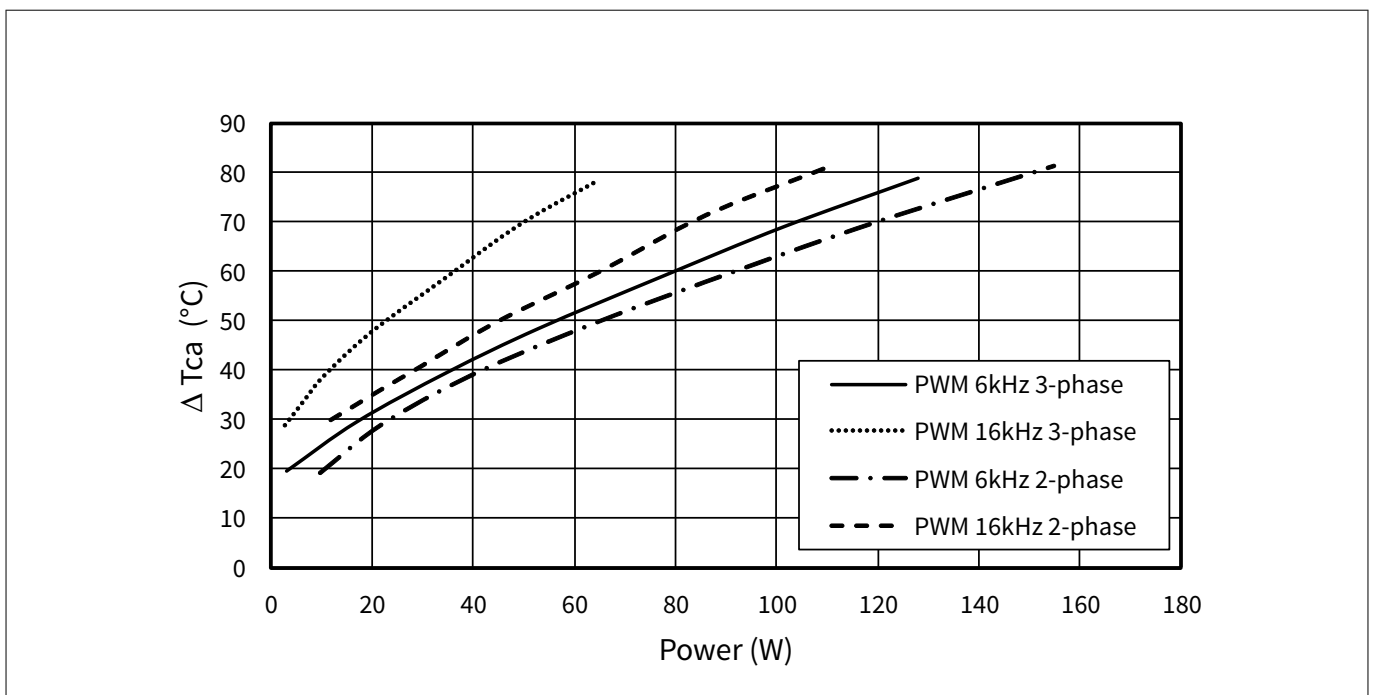
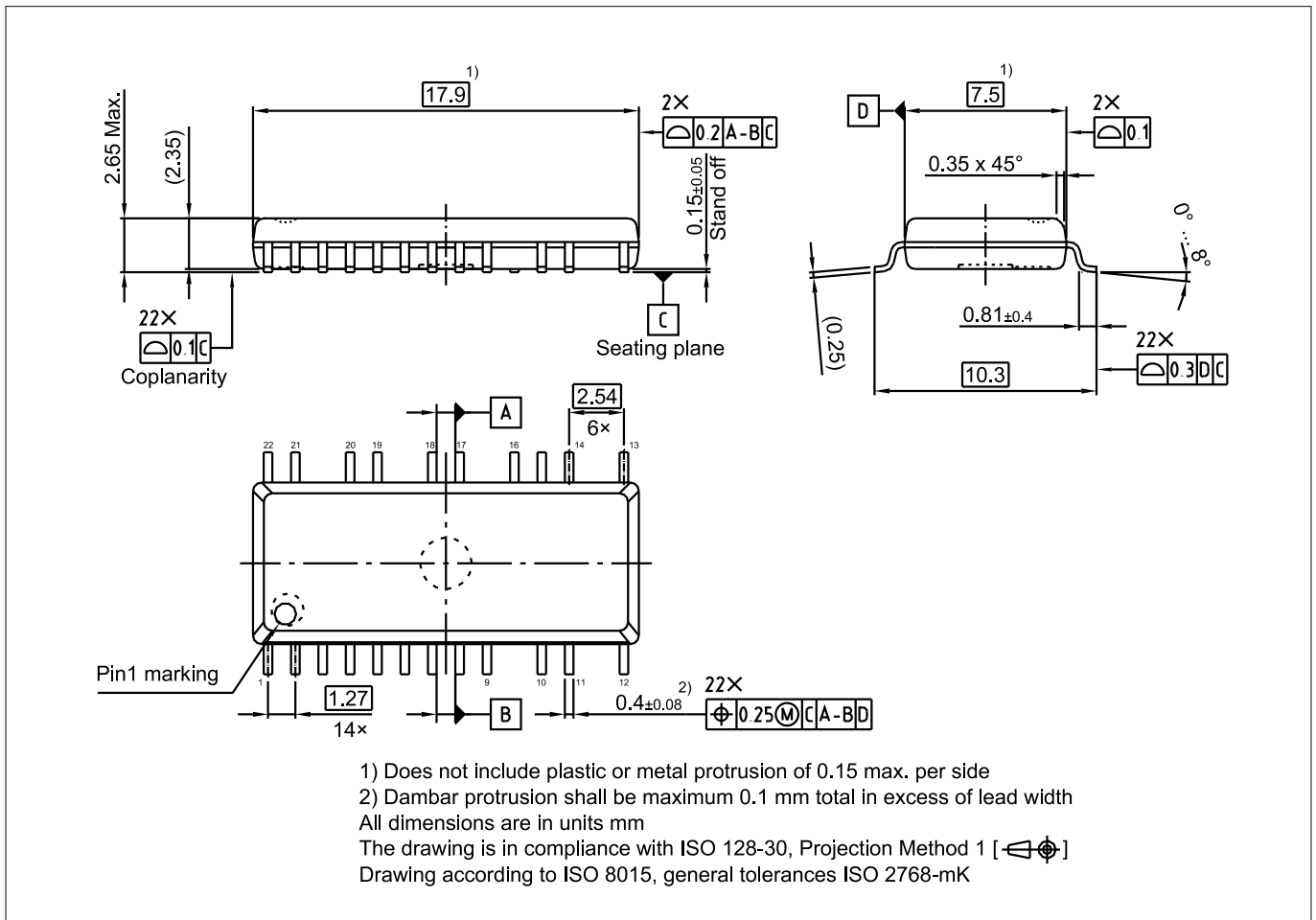

**Figure 16 Typical performance IMI111T-046H**



**5 Device and package specifications**

**5.5 Package outline PG-DSO-22-1**



**Figure 17 PG-DSO-22-1**

**5.6 Part marking information**

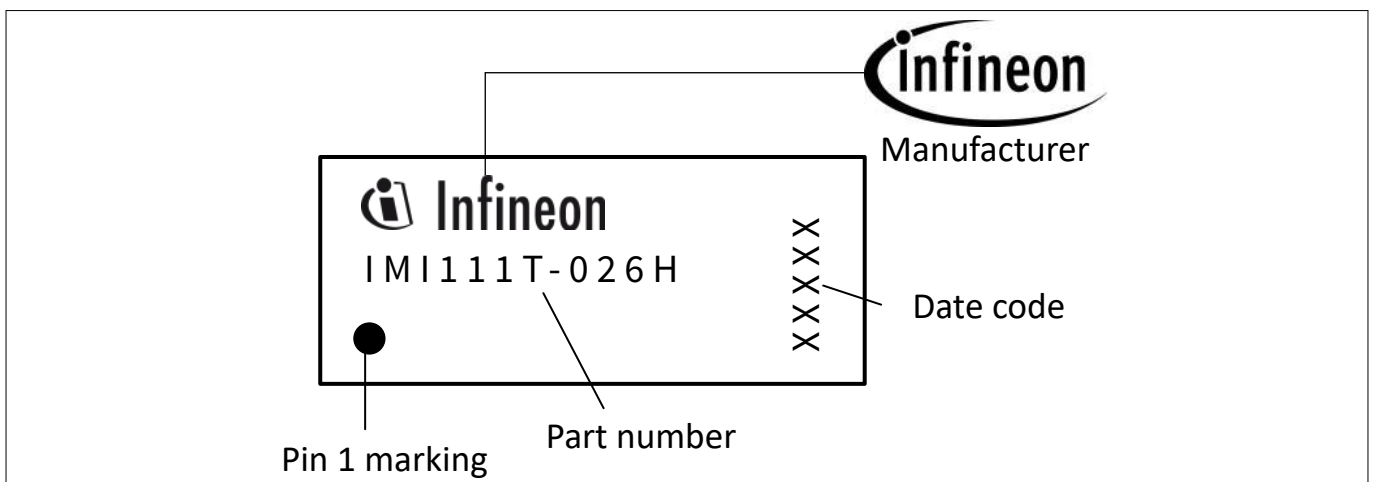

**Figure 18 Part marking**

**Revision history**

**Revision history**

<b>Document version</b>	<b>Date of release</b>	<b>Description of changes</b>	
1.0	2022-04-08	<ul style="list-style-type: none"><li>Initial release</li></ul>	
1.1	2022-12-09	<ul style="list-style-type: none"><li>added typical curves of power vs. temperature</li></ul>	
1.2	2023-06-15	<ul style="list-style-type: none"><li>updated pin 1 and pin 2 names/descriptions ; added RFE pin to GK pin connection description</li></ul>	

## Trademarks

All referenced product or service names and trademarks are the property of their respective owners.

**Edition 2023-06-15**

**Published by**

**Infineon Technologies AG**

**81726 Munich, Germany**

**© 2023 Infineon Technologies AG**

**All Rights Reserved.**

**Do you have a question about any aspect of this document?**

**Email: [erratum@infineon.com](mailto:erratum@infineon.com)**

**Document reference**

**IFX-uwj1643118144516**

## Important notice

The information given in this document shall in no event be regarded as a guarantee of conditions or characteristics ("Beschaffheitsgarantie").

With respect to any examples, hints or any typical values stated herein and/or any information regarding the application of the product, Infineon Technologies hereby disclaims any and all warranties and liabilities of any kind, including without limitation warranties of non-infringement of intellectual property rights of any third party.

In addition, any information given in this document is subject to customer's compliance with its obligations stated in this document and any applicable legal requirements, norms and standards concerning customer's products and any use of the product of Infineon Technologies in customer's applications.

The data contained in this document is exclusively intended for technically trained staff. It is the responsibility of customer's technical departments to evaluate the suitability of the product for the intended application and the completeness of the product information given in this document with respect to such application.

## Warnings

Due to technical requirements products may contain dangerous substances. For information on the types in question please contact your nearest Infineon Technologies office.

Except as otherwise explicitly approved by Infineon Technologies in a written document signed by authorized representatives of Infineon Technologies, Infineon Technologies' products may not be used in any applications where a failure of the product or any consequences of the use thereof can reasonably be expected to result in personal injury.