

NOTES:

1. MATERIALS AND FINISHES:  
 BODY, CONTACT, BUSHING, CLAMP NUT, WASHER - BRASS, GOLD PLATING  
 SPRING - STAINLESS STEEL, SILVER PLATING  
 INSULATOR - TEFLON  
 GASKETS (2) - RUBBER
2. PACKAGING:  
 A. QUANTITY: SINGLE PACK  
 B. NUT, BUSHING, CLAMP(2), GASKET, WASHER(2), CONTACT & BODY ARE PACKAGED LOOSE  
 C. MARKING: BAG TO BE MARKED  
 "AMPHENOL RF, 33-1670-1 , AND DATE CODE"
3. FOR ASSEMBLY INSTRUCTIONS SEE AMPHENOL SPEC. 349-50329

THIRD ANGLE PROJ.

REVISIONS

REV	DESCRIPTION	DATE	ECO	APPR
A	RELEASE TO MFG.	--	--	--
H	REDRAWN & ADDED COD	6/20/13	49534	CL

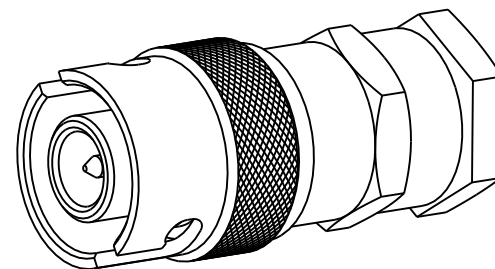

SCALE 3.000

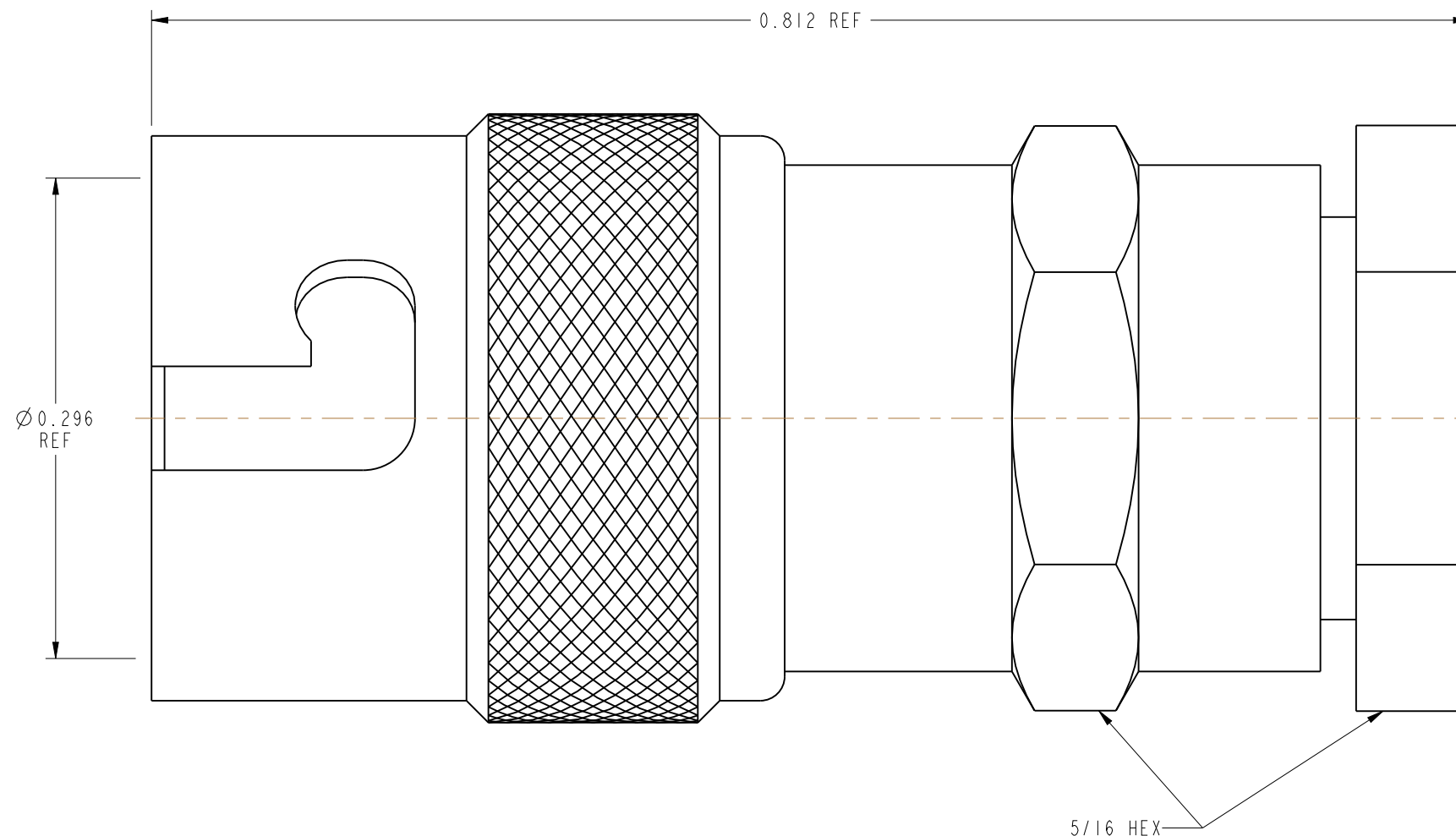
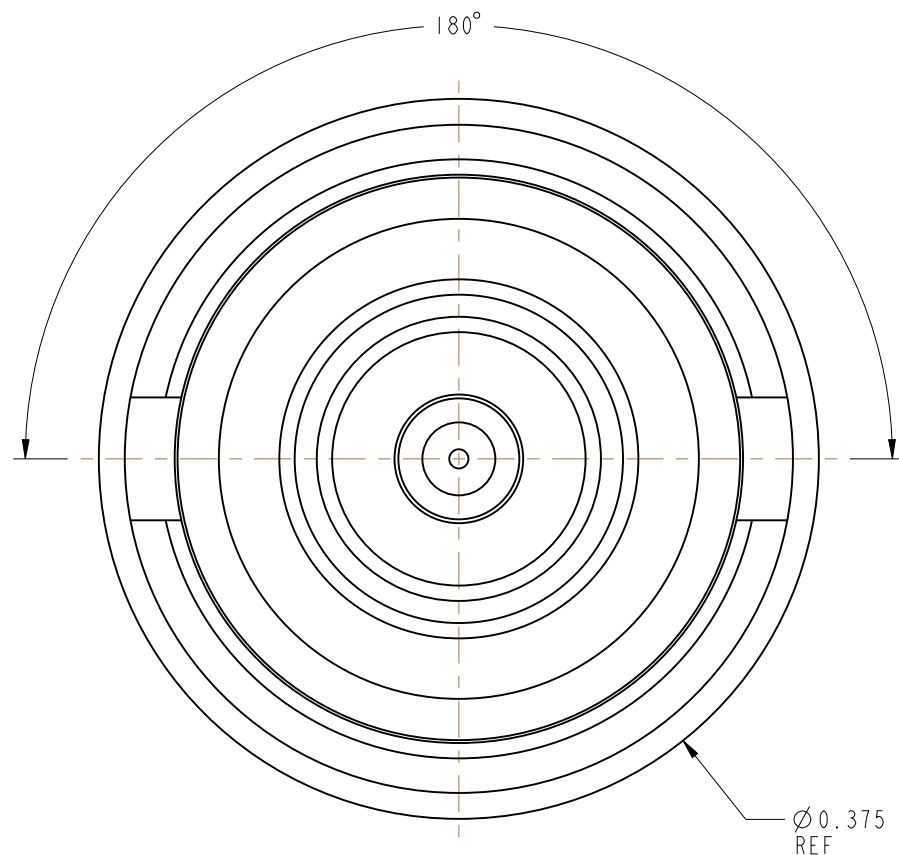

CABLE SPECIFICATIONS			
OUTER JACKET	PRIMARY INSULATION	INNER CONDUCTOR	
Ø .115 MAX	Ø .090 MIN	Ø .066 MAX	.048 MAX

**CUSTOMER OUTLINE DRAWING**  
 ALL OTHER SHEETS ARE FOR INTERNAL USE ONLY

UNLESS OTHERWISE SPECIFIED, DIMENSIONS ARE IN INCHES AND TOLERANCES ARE: 2 PLACE DECIMAL 3 PLACE DECIMAL ANGLES ±.015 (0,381 mm) ±.005 (0,127 mm) ± 1°	MATERIAL	DRAWN	DATE	TITLE	Amphenol RF
	SEE NOTES	CLEMENT	12-Apr-13		
NOTICE - These drawings, specifications, or other data (1) are, and remain the property of Amphenol corp. (2) must be returned upon request; and (3) are confidential and not to be disclosed to any person other than those to whom they are given by Amphenol Corp. the furnishing of these drawings, specifications, or other data by Amphenol Corp., or to any other person to anyone for any purpose is not to be regarded by implication or otherwise in any manner licensing, granting rights to permitting such holder or any other person to manufacture, use or sell any product, process or design, patented or otherwise, that may in any way be related to or disclosed by said drawings, specifications, or other data.	REFERENCE	ENGINEER	DATE	SCALE: 10.0:1.0 SHEET 2 OF 2	DRAWING NO. 33-1670-1
	CONFIGURATION LEVEL: In Work	O. BARTHELMES	01-Jul-02		APPROVED
	FINISH		K. CAPOZZI	6/20/13	DWG SIZE
				B	REV H