

HFBR-1505A/2505A

Fiber Optic Transmitters and Receivers for
Fieldbus Applications

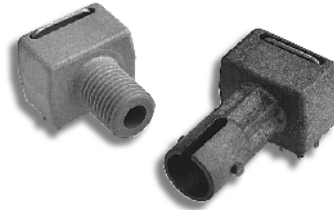

Data Sheet



HFBR-1505A/ 2505A (SMA Tx/ Rx for SERCOS)

HFBR-1515B/ 2515B (ST® Tx/ Rx for PROFIBUS)

HFBR-1505C/ 2505C (SMA Tx/ Rx for INTERBUS-S)

Description

SERCOS

SERCOS, an acronym for **S**ERIAL **R**ealtime **C**OMMUNICATIONS **S**ystem, is a standard digital interface for communication in industrial CNC applications. SERCOS is a European (EN 61491) and international standard (IEC 61491). The optical interface allows data rates of 2, 4, 8, and 16 MBd and data transfer between numerical controls and drives via fiber-optic rings, with voltage isolation and noise immunity. The HFBR-1505A and HFBR-2505A products comply with SERCOS specifications for optical characteristics and connector style, and have guaranteed performance up to 10 MBd. (Typically the 16 MBd required by SERCOS is possible as well but please contact Avago regarding the plan for the 16 MBd device.)

PROFIBUS

PROFIBUS, an acronym of **P**ROcess **F**ield **B**US, is an open fieldbus standard defined for data rates ranging from 9.6 kBd to 12 MBd in selectable steps for wire and optical fiber. PROFIBUS is a German national DIN 19245 standard and a European CENELEC standard EN 50170. The ST® connector is the recommended optical port of the PROFIBUS optical fiber version but other connectors are allowed as well. The HFBR-1515B and HFBR-2515B comply fully to the technical guideline using Plastic Optical Fiber up to 6 MBd, and have a guaranteed performance at data rates up to 10 MBd. (Typically the 12 MBd is possible as well, but please contact Avago regarding the plan for the 12 MBd device.)

INTERBUS-S

INTERBUS-S, a special open Sensor/Actuator Bus, is finding a broad acceptance in the factory automation industry. The HFBR-1505C and HFBR-2505C were specially designed for this application and can be used with 1 mm POF and 200 μ m HCS fiber at the specified data rates of 500 kBd and 2 MBd.

Features

- Meets industrial SERCOS, PROFIBUS, and INTERBUS-S standard
- SMA and ST® ports
- 650 nm wavelength technology
- Specified for use with 1 mm plastic optical fiber and 200 μ m hard clad silica
- Auto-insertable and wave solderable
- DC – 10 MBd data rate

Applications

- Industrial control data links
- Factory automation data links
- Voltage isolation applications
- PLCs
- Motor drives
- Sensor, meter and actuator interfaces

ST® is a registered trademark of AT&T.

HCS® is a registered trademark of SpecTran Corporation.

The optical transmission guideline is a supplement of the German National DIN E 19258 standard draft. On the European level, prEN 50254 is the draft of the INTERBUS-S fieldbus.

Package Information

All HFBR-X5X5X series transmitters and receivers are housed in a low-cost, dual-in-line package that is made of high strength, heat resistant, chemically resistant and UL 94 V-O (UL file # E121562) flame retardant plastic. The transmitters are easily identified by the light grey colored connector port. The receivers are

easily identified by the dark grey colored connector port. The package is designed for auto-insertion and wave soldering so it is ideal for high volume production applications.

Handling and Design Information

When soldering, it is advisable to leave the protective cap on the unit to keep the optics clean. Good system performance requires clean port optics and cable ferrules to avoid obstructing the optical path. Clean compressed air often is sufficient to remove particles of dirt; methanol on a cotton swab also works well.

Recommended Chemicals for Cleaning/ Degreasing X5X5X Products

Alcohols: methyl, isopropyl, isobutyl.

Aliphatics: hexane, heptane.

Other: soap solution, naphtha.

Do not use partially halogenated hydrocarbons such as 1,1,1 trichloroethane, ketones such as MEK, acetone, chloroform, ethyl acetate, methylene dichloride, phenol, methylene chloride or N-methylpyrrolidone. Also, Avago does not recommend the use of cleaners that use halogenated hydrocarbons because of their potential environmental harm.

CAUTION: The small junction size inherent in the design of these components increases the components' susceptibility to damage from electrostatic discharge (ESD). It is advised that normal static precautions be taken in handling and assembly of these components to prevent damage and/or degradation which may be induced by ESD.

Specified Link Performance

0° C to +70° C unless otherwise noted.

Parameter	Symbol	Min.	Max.	Unit	Condition	Reference
Link Distance with HFBR-1505A/ 2505A or HFBR-1515B/ 2515B	1	0.1	40	m	POF	Notes 1,2,3,4,6
		0.1	200	m	HCS®	Notes 1,2,3,5,6
Link Distance with HFBR-1505C/ 2505C	1	0.1	50	m	POF	Notes 1,2,3,4,7
		0.1	400	m	HCS®	Notes 1,2,3,5,7
Pulse Width Distortion with HFBR-1505A/ 2505A or HFBR-1515B/ 2515B	PWD	-30	+30	ns	25% to 75% duty cycle	Note 1
Pulse Width Distortion with HFBR-1505C/ 2505C	PWD	-125	+125	ns	arbitrary duty cycle	Note 1

Notes:

1. With recommended Tx and Rx circuits (60 mA nominal drive current).
2. POF HFBR-Exxxxx 0.23 dB/ m worst case attenuation.
3. HCS® 10 dB/ km worst case attenuation.
4. Including a 3 dB optical safety margin accounting for link service lifetime.
5. Including a 2 dB optical safety margin accounting for link service lifetime.
6. Signaling rate DC to 10 MBd.
7. Signaling rate DC to 2 MBd.

HFBR-15X5X Transmitters

The HFBR-15X5X transmitter incorporates a 650 nm LED in a light gray nonconductive plastic housing. The high light output power enables the use of both plastic optical fiber (POF) and

Hard Clad Silica (HCS®). This transmitter can be operated up to 10 MBd using a simple driver circuit. The HFBR-1505X is compatible with SMA connectors, while the HFBR-1515X mates with ST® connectors.

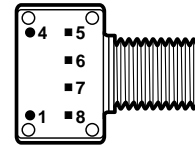

BOTTOM VIEW,
HFBR-15x5x

SEE NOTE 10

PIN	FUNCTION
1	CONNECTED TO PIN 4
4	CONNECTED TO PIN 1
5	GND
6	GND
7	CATHODE
8	ANODE

Absolute Maximum Ratings

Parameter	Symbol	Min.	Max.	Unit	Reference
Storage and Operating Temperature	$T_{S,O}$	-40	85	°C	
Peak Forward Input Current	$I_{F,PK}$		90	mA	Note 6
Average Forward Input Current $I_{F,AVG}$		60	mA		
Reverse Input Voltage	V_R		3	V	
Lead Soldering Cycle	Temp	T_{SOL}	260	°C	Note 7
	Time		10	s	

Electrical/ Optical Characteristics

0°C to +70°C unless otherwise noted.

Parameter	Symbol	Min.	Typ. ^[1]	Max.	Unit	Condition	Ref.
Optical Power Temperature Coefficient	$\Delta P_T / \Delta T$		-0.02		dB/ °C		
Forward Voltage	V_F	1.8	2.1	2.65	V	$I_{F,dc} = 60 \text{ mA}$	Fig. 1
Forward Voltage Temperature Coefficient	$\Delta V_F / \Delta T$		-1.8		mV/ °C		Fig. 1
Breakdown Voltage	V_{BR}	3.0	13		V	$I_{F,dc} = -10 \infty \text{ A}$	
Peak Emission Wavelength	λ_{PK}	640	650	660	nm		Fig. 3
Full Width Half Max	FWHM		21	30	nm		Fig. 3
Diode Capacitance	C_O		60		pF	$V_F = 0 \text{ V}, f = 1 \text{ MHz}$	
Thermal Resistance	θ_{JC}		140		°C/ W		Notes 4,5
Rise Time (10% to 90%)	t_r		13		ns	10% to 90%,	
Fall Time (90% to 10%)	t_f		10		ns	$I_F = 60 \text{ mA}$	

EYE SAFETY: The HFBR-15x5x is a Class 1 LED Product and eye safe when used within the data sheet limits and under normal operating conditions. This includes all reasonably foreseeable single fault conditions per IEC60825-1 and amendments.

Peak Output Power

0°C to +70°C unless otherwise noted.

Model Number	Symbol	Min.	Max.	Unit	Condition	Reference
HFBR-1505A	P_T	-10.5	-5.5	dBm	POF, $I_{F,dc} = 35$ mA	Notes 2,3,11
SERCOS		-7.5	-3.5		POF, $I_{F,dc} = 60$ mA	Figure 2
		-18.0	-10		HCS [®] , $I_{F,dc} = 60$ mA	
HFBR-1515B		-10.5	-5.5		POF, $I_{F,dc} = 35$ mA	Notes 2,3,11
PROFIBUS		-7.5	-3.5		POF, $I_{F,dc} = 60$ mA	Figure 2
		-18.0	-8.5		HCS [®] , $I_{F,dc} = 60$ mA	
HFBR-1505C		-6.2	0.0		POF, $I_{F,dc} = 60$ mA	Notes 3,8,9
INTERBUS-S		-16.9	-8.5		HCS [®] , $I_{F,dc} = 60$ mA	Figure 2

Notes:

1. Typical data at 25°C.
2. Optical power measured at the end of 0.5 meters of 1 mm diameter plastic optical fiber with a large area detector.
3. Minimum and maximum values for P_T over temperature are based on a fixed drive current. The recommended drive circuit has temperature compensation which reduces the variation in P_T over temperature, refer to Figures 4 and 6.
4. Thermal resistance is measured with the transmitter coupled to a connector assembly and fiber, and mounted on a printed circuit board.
5. To further reduce the thermal resistance, the cathode trace should be made as large as is consistent with good RF circuit design.
6. For $I_{F,PK} > 60$ mA, the duty factor must maintain $I_{F,AVG} \leq 60$ mA and pulse width ≤ 1 μ s.
7. 1.6 mm below seating plane.
8. Minimum peak output power at 25°C is -5.3 dBm (POF) and -16.0 dBm (HCS[®]) for 1505C series only.
9. Optical power measured at the end of 1 meter of 1 mm diameter plastic or 200 μ m hard clad silica optical fiber with a large area detector.
10. Pins 1 and 4 are for mounting and retaining purposes, but are electrically connected; pins 5 and 6 are electrically isolated. It is recommended that pins 1, 4, 5, and 6 all be connected to ground to reduce coupling of electrical noise.
11. Output power with 200 μ m hard clad silica optical fiber assumes a typical -10.5 dB difference compared to 1 mm plastic optical fiber.

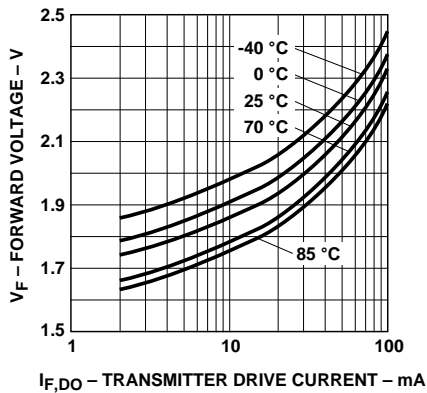

Figure 1. Typical forward voltage vs. drive current.

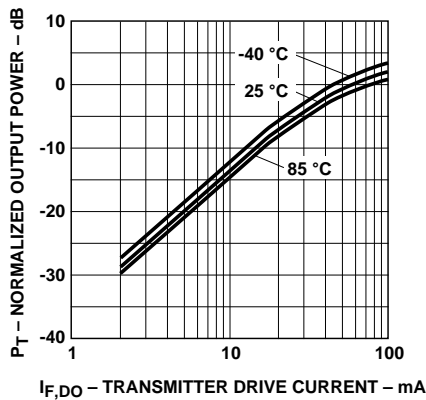

Figure 2. Typical normalized optical power vs. drive current.

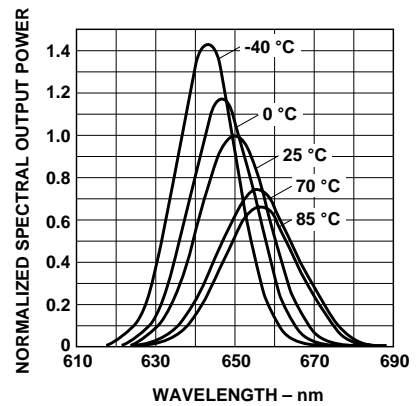

Figure 3. Typical normalized optical spectra.

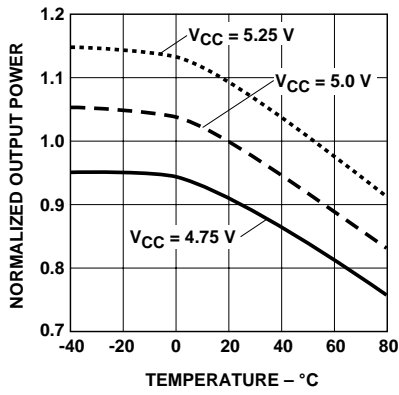

Figure 4. Typical normalized optical power vs. temperature (in recommended drive circuit).

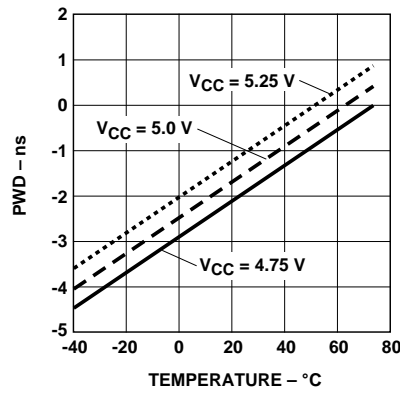

Figure 5. Typical optical pulse width distortion vs. temperature and power supply voltage (in recommended drive circuit).

Recommended Drive Circuit for HFBR-x505A/ x515B

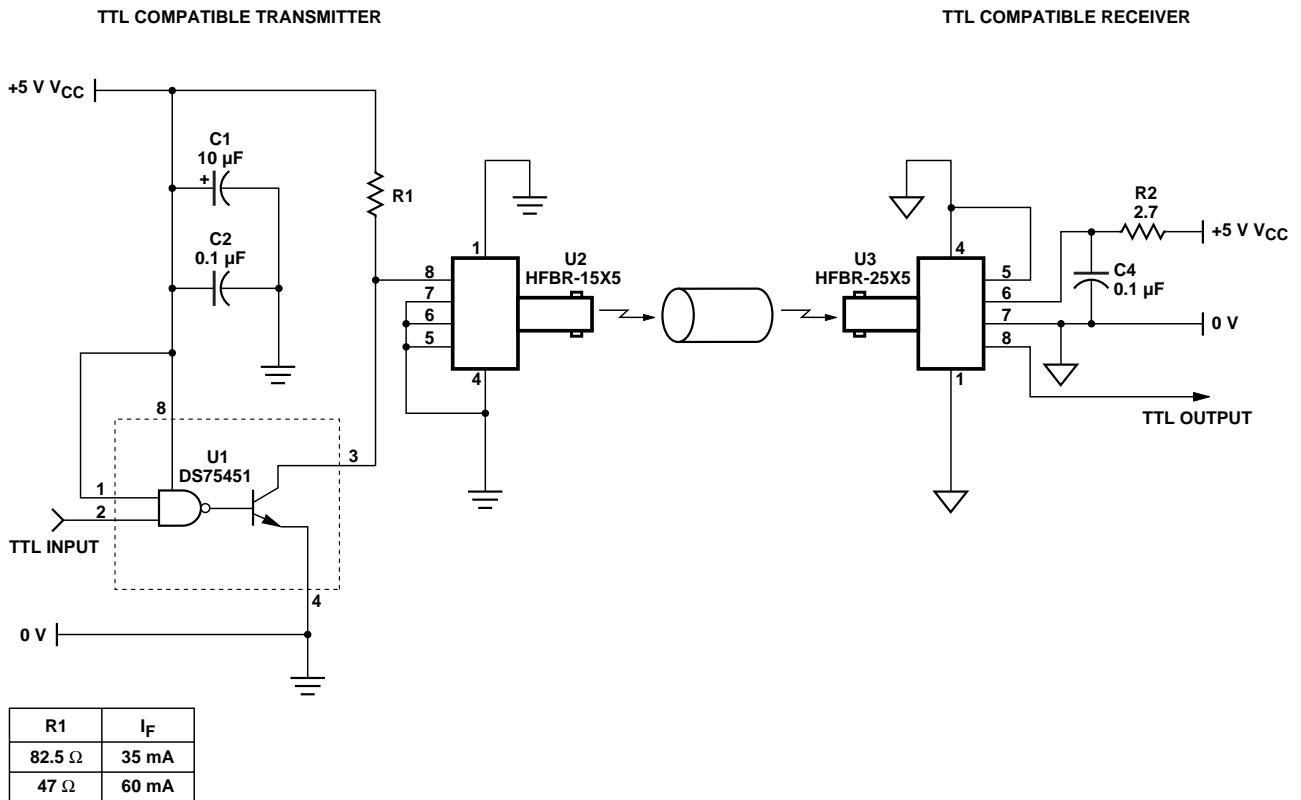
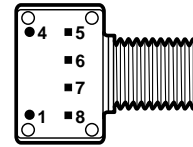

Figure 6. Recommended transmitter and receiver drive circuit (I_{F, on} = 35 mA or 60 mA nominal at T_A = 25°C).

HFBR-25x5A/ B Receivers

The HFBR-25x5A/B receiver consists of a silicon PIN photodiode and digitizing IC to produce a logic compatible output. The IC includes a unique circuit to correct the pulse width distortion of the first bit after a long idle period. This enables operation from DC to 10 MBd

with low PWD for arbitrary data patterns. The receiver output is a “push-pull” stage compatible with TTL and CMOS logic. The receiver housing is a dark grey, conductive plastic. The HFBR-2505A is compatible with SMA connectors, while the HFBR-2515B mates with ST® connectors.



BOTTOM VIEW,
HFBR 25x5A/B

SEE NOTE 4

PIN	FUNCTION
1	CONNECTED TO PIN 4
4	CONNECTED TO PIN 1
5	NO CONNECT
6	V _{CC}
7	GND
8	V _O

Absolute Maximum Ratings

Parameter	Symbol	Min.	Max.	Unit	Reference
Storage and Operating Temperature	T _S	-40	85	°C	
Supply Voltage	V _{CC}	-0.5	+5.5	V	
Average Output Current	I _{O,AVG}	-16	+16	mA	
Output Power Dissipation	P _{OD}		80	mW	
Lead Soldering Cycle	Temp		260	°C	Note 2
	Time		10	s	

Electrical/ Optical Characteristics

0°C to +70°C, 4.75 V < V_{CC} < 5.25 V, V_{P-P} Noise ≤100 mV unless otherwise noted.

Parameter	Symbol	Min.	Typ. ^[1]	Max.	Unit	Condition	Ref.
Peak Input Power Level Logic HIGH	P _{RH}			-42 -44	dBm	1mm POFNotes 3,5 200 μm HCS®	
Peak Input Power Level Logic LOW	P _{RL}	-20 -22		-0 -2	dBm	1 mm POF, 200 μm HCS® PWD < 30 ns	Note 3 Figs. 7,8, 9,10
Supply Current	I _{CC}		27	45	mA	V _O = Open	
High Level Output Voltage	V _{OH}	4.2	4.7		V	I _O = -40 μA	
Low Level Output Voltage	V _{OH}		0.22	0.4	V	I _O = +1.6 mA	
Output Rise Time	t _r		12	30	ns	C _L = 10 pFNote 3	
Output Fall Time	t _f		10	30	ns	C _L = 10 pF	Note 3

Notes:

- Typical data are at 25°C, V_{CC} = 5.0 V.
- 1.6 mm below seating plane.
- In recommended receiver circuit, with an optical signal from the recommended transmitter circuit.
- Pins 1 and 4 are electrically connected to the conductive housing and are also used for mounting and retaining purposes. It is required that pin 1 and 4 be connected to ground to maintain conductive housing shield effectiveness.
- BER ≤ 10E-9, includes a 10.8 dB margin below the receiver switching threshold level (signal to noise ratio = 12).

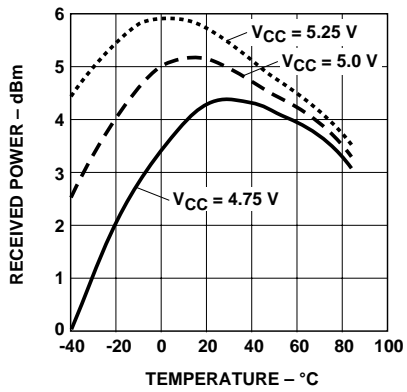

Figure 7. Typical POE receiver overdrive $P_{RL,max}$ at 10 MBd vs. temperature and power supply voltage.

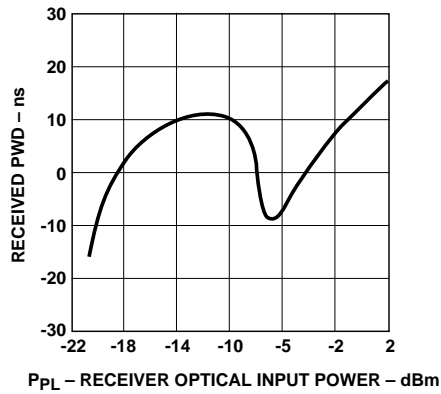

Figure 8. Typical POE receiver pulse width distortion vs. optical power at 10 MBd.

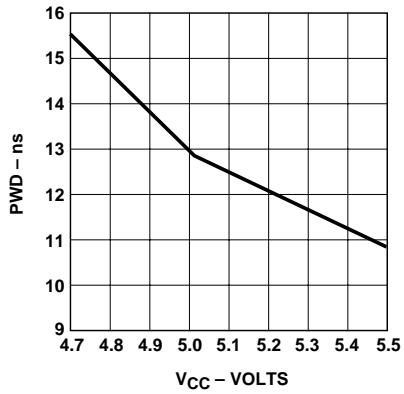

Figure 9. Typical POE receiver pulse width distortion vs. power supply voltage at high optical power, (0 dBm, 10 MBd).

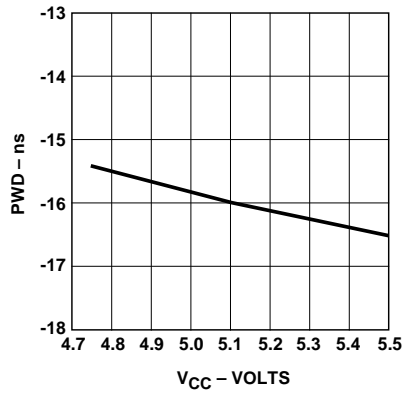
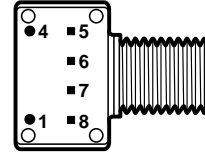

Figure 10. Typical POE receiver pulse width distortion vs. power supply voltage at low optical power, (-21 dBm, 10 MBd).

HFBR-2505C Receiver

The HFBR-2505C receiver includes a monolithic DC coupled, digital IC receiver with open collector Schottky output transistor. An internal pullup resistor to V_{CC} is available at

pin 5. The receiver housing is a dark gray conductive plastic and the optical port is compatible with SMA connectors. The specified signal rate of HFBR-2505C is 2 MBd.



BOTTOM VIEW,
HFBR 2505C

SEE NOTE 3

PIN	FUNCTION
1	CONNECTED TO PIN 4
4	CONNECTED TO PIN 1
5	R_L
6	V_{CC}
7	GND
8	V_O

Absolute Maximum Ratings

Parameter	Symbol	Min.	Max.	Units	Reference
Storage & Operating Temperatures	$T_{S,O}$	-40	+85	$^{\circ}C$	
Lead Soldering Cycle	Temp.		260	$^{\circ}C$	Note 1
	Time		10	sec	
Supply Voltage	V_{CC}	-0.5	7	V	Note 2
Output Collector Current	I_{OAV}		25	mA	
Output Collector Power Dissipation	P_{OD}		40	mW	
Output Voltage	V_O	-0.5	18	V	
Pull-up Voltage	V_P	-5	V_{CC}	V	
Fan Out (TTL)	N		5		

Notes:

- 1.6 mm below seating plane.
- It is essential that a bypass capacitor 0.1 μF be connected from pin 6 to pin 7 of the receiver. Total lead length between both ends of the capacitor and the pins should not exceed 20 mm.
- Pins 1 and 4 are electrically connected to the conductive housing and are also used for mounting and retaining purposes. It is required that pin 1 and 4 be connected to ground to maintain conductive housing shield effectiveness.

Receiver Electrical/ Optical Characteristics

0°C to 70°C, 4.75 V ≤ V_{CC} ≤ 5.25 V unless otherwise specified

Parameter	Symbol	Min.	Typ.	Max.	Units	Conditions	Ref.
Input Optical Power Level for Logic "0"	P _{R(L)}	-21.6		-2.0	dBm	V _{OL} = 0.5 V I _{OL} = 8 mA 1 mm POF	Notes 1, 2
		-23.0				V _{OL} = 0.5 V I _{OL} = 8 mA 200 μm HCS	
Input Optical Power Level for Logic "1"	P _{R(H)}			-43	dBm	V _{OL} = 5.25 V I _{OH} ≤ 250 μA	Note 1
High Level Output Current	I _{OH}		5	250	μA	V _O = 18 V, P _R = 0	Note 3
Low Level Output Current	V _{OL}		0.4	0.5	V	I _{OL} = 8 mA, P _R = P _{R(L)MIN}	Note 3
High Level Supply Current	I _{COH}		3.5	6.3	mA	V _{CC} = 5.25 V, P _R = 0	Note 3
Low Level Supply Current	I _{COL}		6.2	10	mA	V _{CC} = 5.25 V P _R = -12.5 dBm	Note 3
Effective Diameter	D		1		mm		
Numerical Aperture	NA		0.5				
Internal Pull-up Resistor	R _L	680	1000	1700	Ω		

Notes:

- Optical flux, P (dBm) = 10 Log [P (μW) / 1000 μW].
- Measured at the end of the fiber optic cable with large area detector.
- R_L is open.

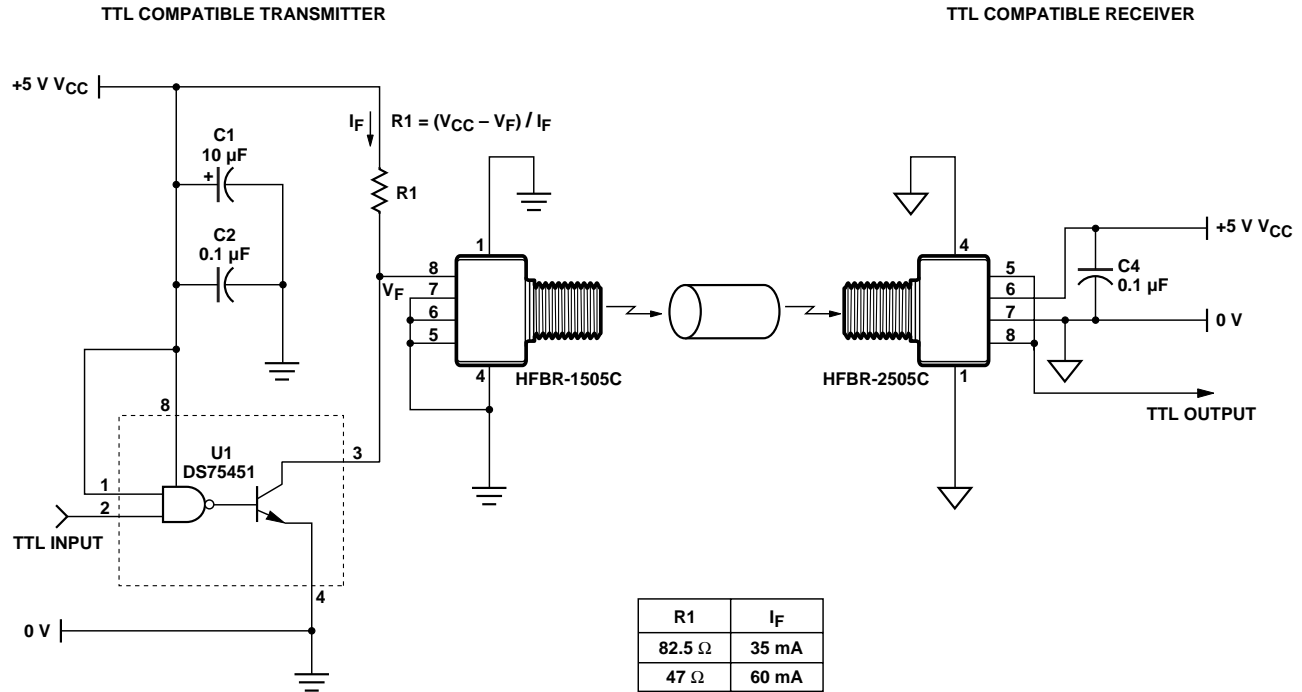
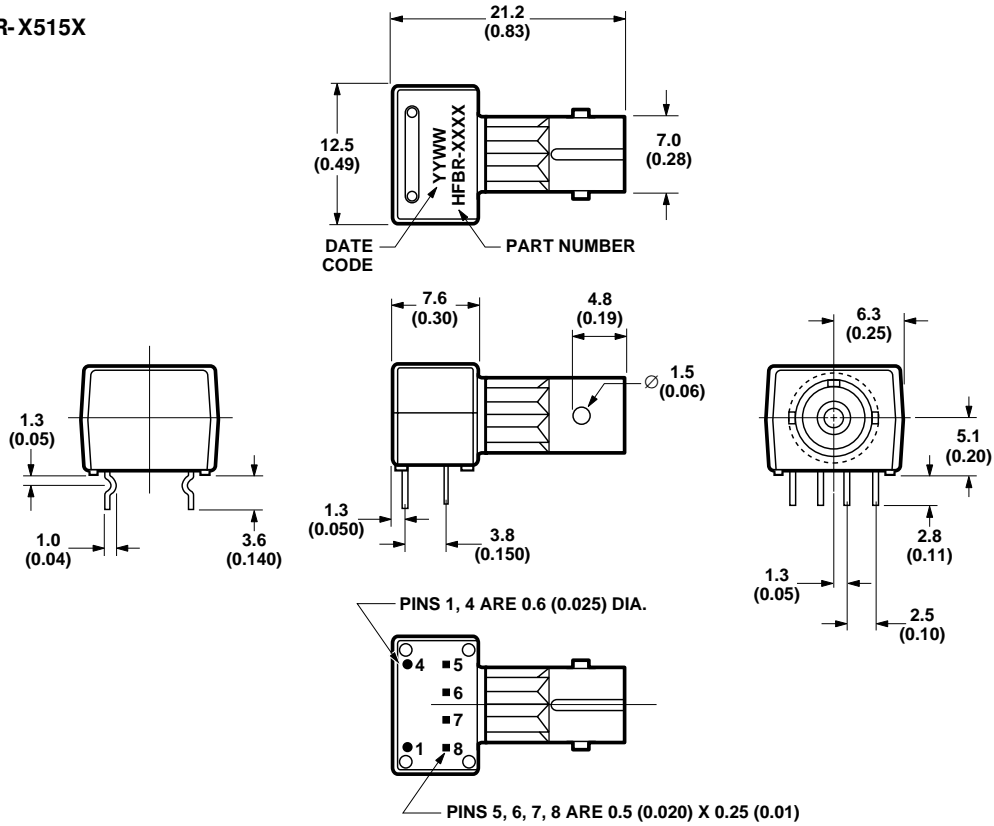

Figure 11. Typical interface circuit.

Mechanical Dimensions

HFBR-X515X



HFBR-X505X

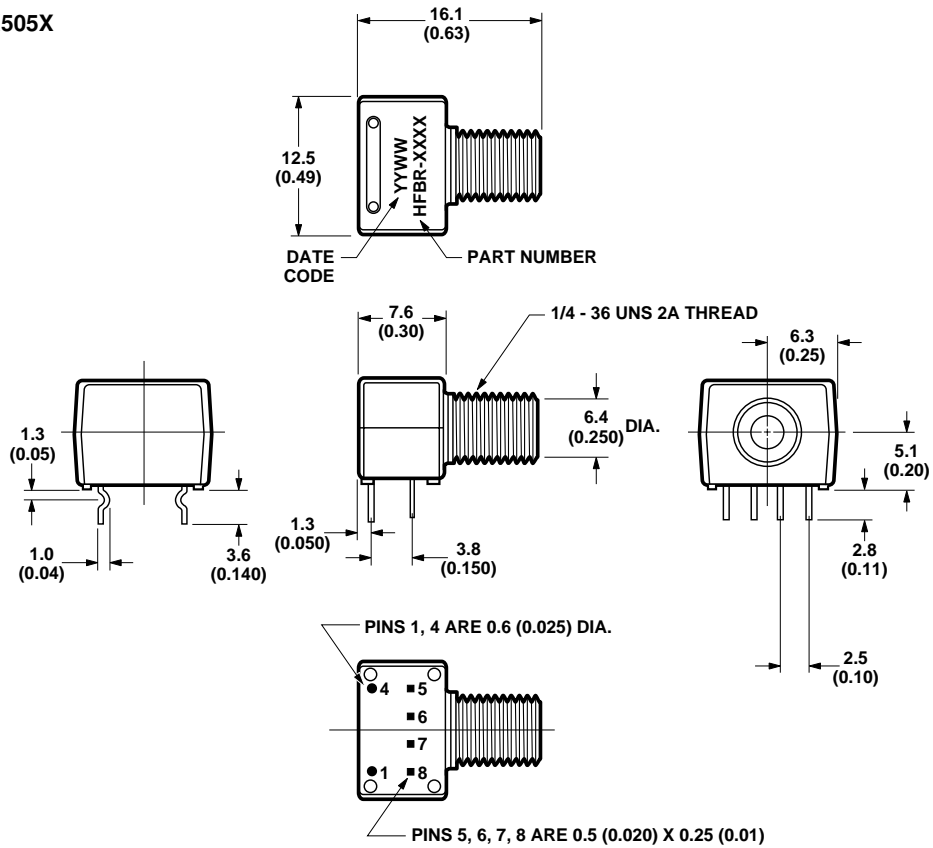

For product information and a complete list of distributors, please go to our website: www.avagotech.com

Avago, Avago Technologies, and the A logo are trademarks of Avago Technologies, Pte. in the United States and other countries.
Data subject to change. Copyright © 2006 Avago Technologies Pte. All rights reserved. Obsoletes 5966-3153E
5988-1764EN April 10, 2006

