

Atmel SAM4E-EK Board

Introduction

This user guide introduces the SAM4E-EK Evaluation Kit (SAM4E-EK) and describes its development and debugging capabilities.

Table of Contents

1	Introduction.....	3
1.1	User Guide	3
1.2	References and Applicable Documents.....	3
2	Kit Contents	3
2.1	Deliverables.....	3
2.2	Electrostatic Warning	4
3	Power Up	5
3.1	Power Up the Board	5
3.2	Source Code and Technical Support.....	5
4	Board Description.....	6
4.1	Board Overview.....	6
4.2	Features List.....	7
4.3	Function Blocks	7
4.3.1	Processor	7
4.3.2	Memory.....	7
4.3.3	Clock Circuitry.....	8
4.3.4	Reset Circuitry	9
4.3.5	Power Supply and Management.....	9
4.3.6	UART	11
4.3.7	USART	11
4.3.8	RS485.....	12
4.3.9	Ethernet MAC 10/100 (EMAC).....	13
4.3.10	CAN	13
4.3.11	Display Interface	14
4.3.12	Touch Screen Interface	16
4.3.13	JTAG/ICE	16
4.3.14	Audio Interface.....	17
4.3.15	USB Device	18
4.3.16	Analog Interface.....	18
4.3.16.1	Analog Reference	18
4.3.16.2	Analog Input.....	19
4.3.16.3	Analog Output.....	20
4.3.17	QTouch Elements	20
4.3.18	LEDs.....	21
4.3.19	SD/MMC Card	21
4.3.20	ZigBee	22
4.3.21	PIO Expansion.....	22
5	Configuration	24
5.1	PIO Usage.....	24
5.2	Jumpers	27
6	Schematics.....	29
7	ATMEL EVALUATION BOARD/KIT IMPORTANT NOTICE AND DISCLAIMER	38
8	Revision History	39

1 Introduction

1.1 User Guide

This user guide gives details on how the Atmel® SAM4E-EK has been designed. It is made up of six chapters:

- Chapter 1 includes references, applicable documents
- Chapter 2 describes the kit contents, ESD warnings
- Chapter 3 provides instructions to power up the SAM4E-EK and technical support
- Chapter 4 describes overview, feature list, the hardware resources including the schematics
- Chapter 5 provides configurations and jumper settings
- Chapter 6 provides the entire board schematics

1.2 References and Applicable Documents

Table 1-1. References and Applicable Documents

Reference	Title	Comment
Lit. no.: 11157	SAM4E datasheet	www.atmel.com

2 Kit Contents

2.1 Deliverables

The Atmel SAM4E-EK toolkit contains the following items:

- An Atmel SAM4E-EK board
- Power supply
- Universal input AC/DC power supply with US, Europe, and UK plug adapters
- One USB cable
- One serial RS232 cable
- One Ethernet cross cable
- A welcome letter

Figure 2-1. Unpacked SAM4E-EK



Unpack and inspect the kit carefully. Contact your local [Atmel distributor](#) if you have issues concerning the contents of the kit.

2.2 Electrostatic Warning

The Atmel SAM4E-EK board is shipped in a protective anti-static bag. The board must not be subjected to high electrostatic potentials. A grounding strap or similar protective device should be worn when handling the board. Avoid touching the components or any other metallic element of the board.

3 Power Up

3.1 Power Up the Board

Unpack the board taking care to avoid electrostatic discharge. Unpack the power supply, select the right power plug adapter corresponding to that of your country, and insert it into the power supply.

Connect the power supply DC connector to the board and plug the power supply to an AC power socket.

The board LCD should light up and display a welcome page. Then click or touch the icons displayed on the screen and enjoy the demo.

3.2 Source Code and Technical Support

After boot up, you can run some sample code or your own application on the development kit. You can download sample code and get technical support from the Atmel web site: <http://www.atmel.com>.

4 Board Description

4.1 Board Overview

This chapter introduces the Atmel SAM4E-EK Evaluation Kit design. It introduces system-level concepts, such as power distribution, memory, and interface assignments.

The SAM4E-EK board is based on the integration of an ARM® Cortex™-M4 processor with on-board NAND Flash and a set of popular peripherals. It is designed to provide a high performance processor evaluation solution with high flexibility for various kinds of applications.

Figure 4-1. SAM4E-EK Block Diagram

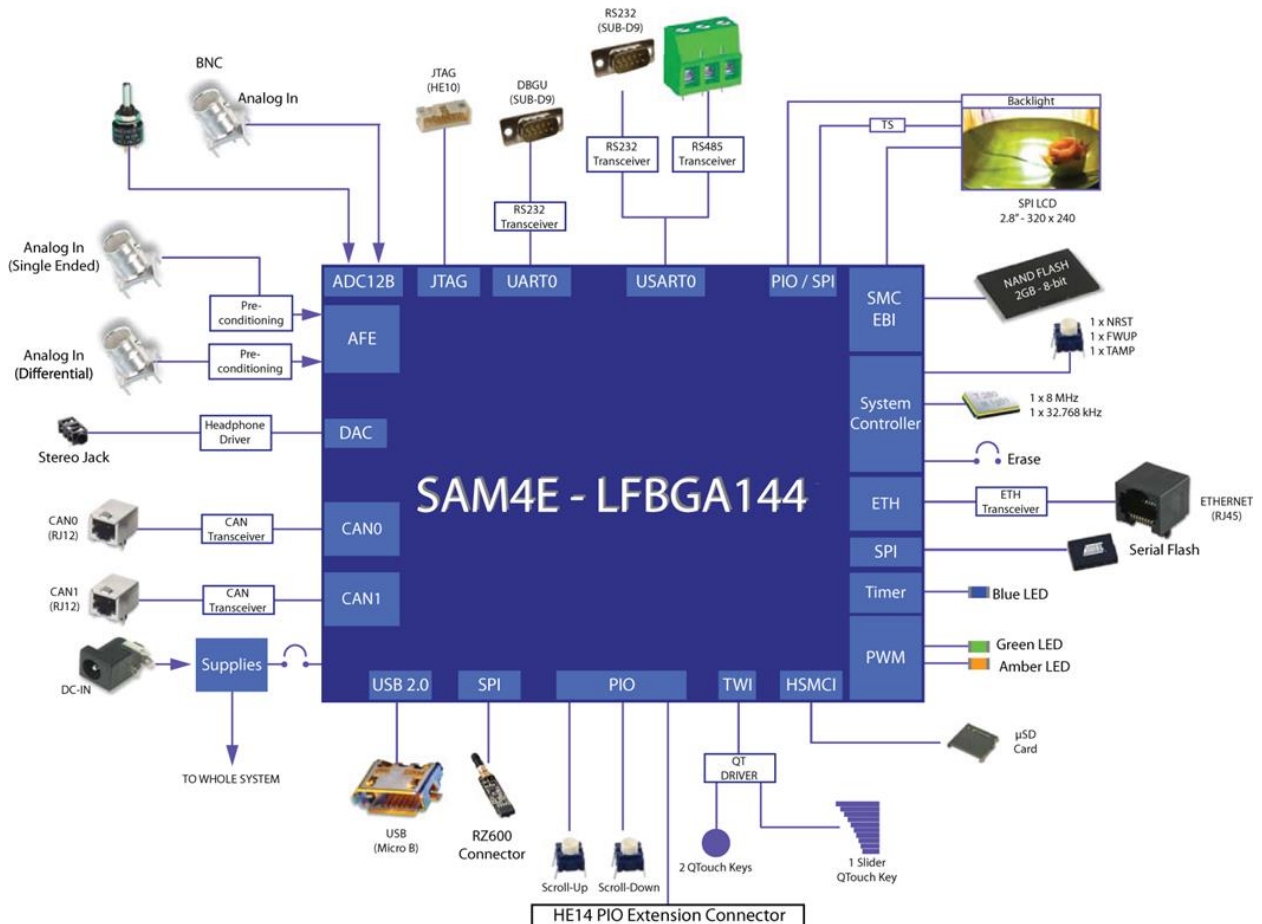

4.2 Features List

The main board components and interfaces:

- SAM4E16 chip BGA144 package with optional socket footprint
- 12MHz crystal
- 32.768kHz crystal
- Optional SMB connector for external system clock input
- NAND Flash
- 2.8 inch TFT color LCD display with touch panel and backlight
- UART port with RS232 driver
- USART port with RS232 driver multiplexed with RS485 function with driver
- CAN port with driver
- Mono/stereo headphone jack output
- One Ethernet physical transceiver layer with RJ45 connector
- SD/MMC interface
- Reset button: NRST
- User buttons: WAKU, TAMP, Scroll-up, and Scroll-down
- QTouch® buttons: Left, Right, and Slider
- Full Speed USB device port
- JTAG/ICE port
- On-board power regulation
- Three user LEDs
- Power LED
- BNC connector for ADC input
- BNC connector for DAC output
- User potentiometer connected to the ADC input
- ZigBee® connector
- PIO connection interfaces (PIOA, PIOC and PIOD with 32-bit, PIOB with 16-bit, and PIOE with 6-bit)

4.3 Function Blocks

4.3.1 Processor

The Atmel SAM4E-EK is equipped with a SAM4E16 device in BGA144 package.

4.3.2 Memory

The SAM4E16 chip embeds:

- 1024kB of embedded Flash
- 128kB of embedded SRAM
- 16kB of ROM with embedded boot loader routines (UART, USB) and In-Application Programming functions (IAP) routines

The SAM4E16 features an External Bus Interface (EBI) that permits interfacing to a broad range of external memories and virtually to any parallel peripheral.

The SAM4E-EK board is equipped with one NAND Flash MT29F2G08ABAEA on the EBI. This can change to other type of flash by setting the Static Memory Controller.

Figure 4-2. NAND-Flash

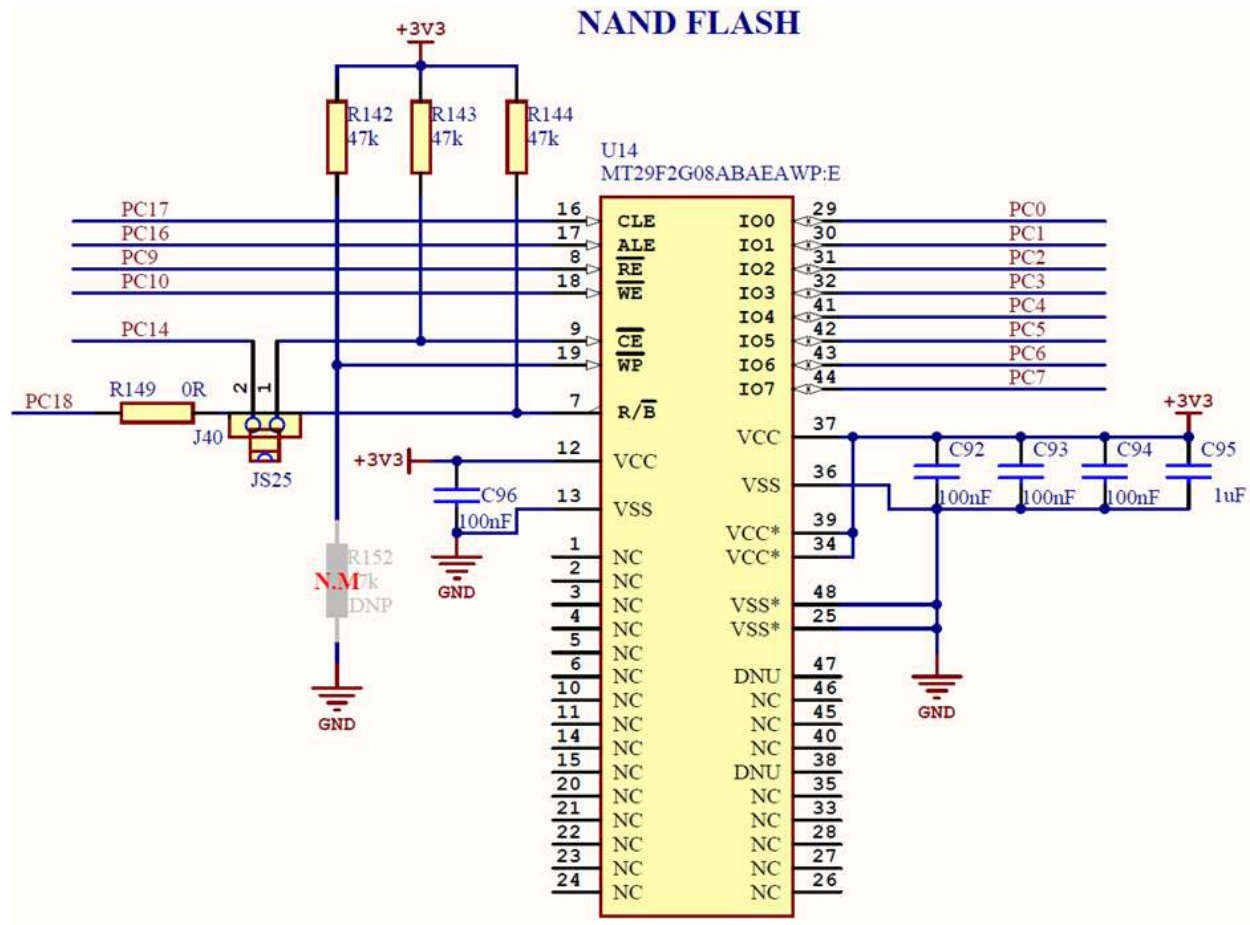

NCS0 chip select signal is used for NAND Flash chip selection. Furthermore, a dedicated jumper can disconnect it from the on-board memories, thereby letting NCS0 free for other custom purposes.

4.3.3 Clock Circuitry

The clock generator of a SAM4E16 microcontroller is composed of:

- A low-power 32.768Hz Slow Clock Oscillator with bypass mode
- A 3 to 20MHz Crystal Oscillator, which can be bypassed (12MHz needed in case of USB)
- A factory programmed fast internal RC Oscillator. Three output frequencies can be selected: 4 (default value), 8, or 12MHz.
- A 80 to 240MHz PLL (PLLB) providing a clock for the USB Full Speed Controller
- An 80 to 240MHz programmable PLL (PLLA), capable to provide the clock MCK to the processor and to the peripherals. The input frequency of PLLA is from 3 to 32MHz.

The SAM4E-EK board is equipped with one 12MHz crystal, optional Piezoelectric Ceramic Resonator 12MHz (Murata ref. CSTCE12M0G15L99-R0), one 32.768Hz crystal and an external clock input connector.

Figure 4-3. External Clock Source

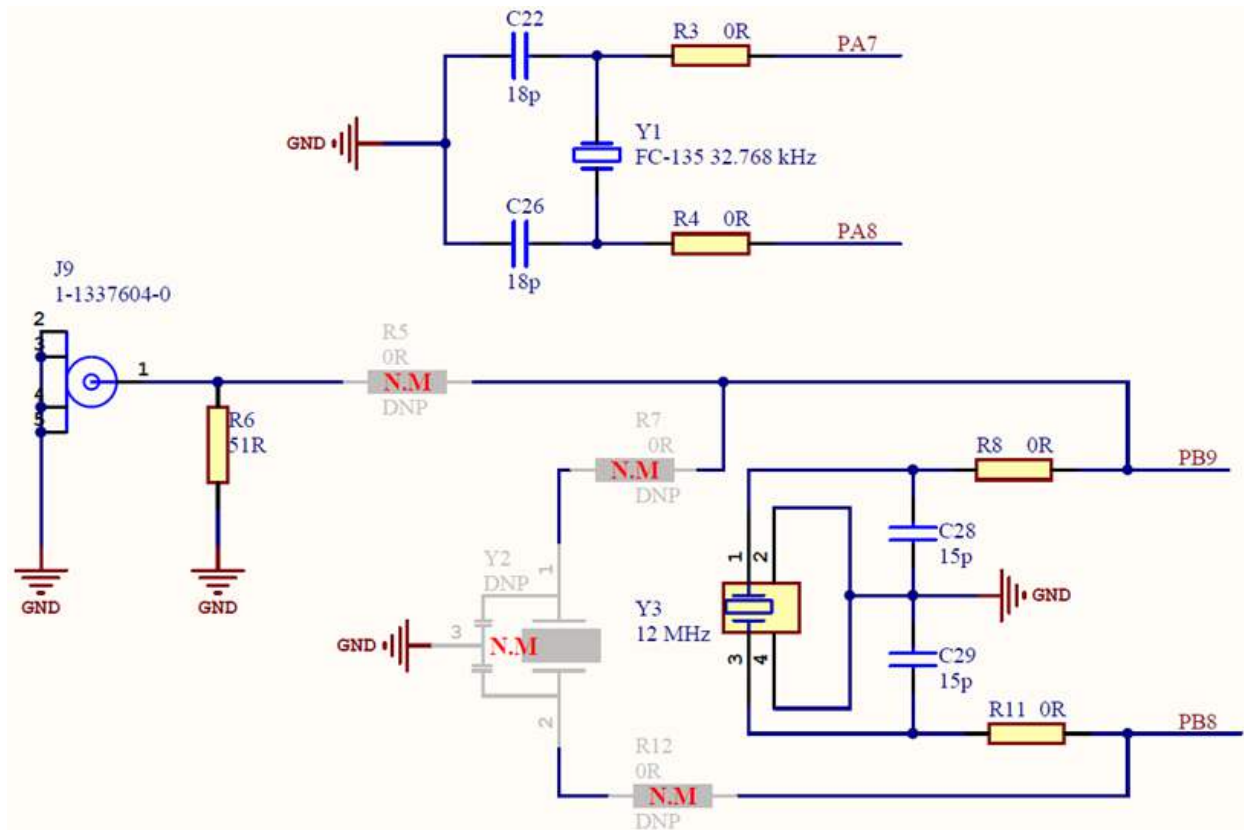

4.3.4 Reset Circuitry

On-board NRST button SW1 provides an external reset control of the SAM4E16.

The NRST pin is bidirectional. It is handled by the on-chip reset controller. It can be driven low to provide a reset signal out to the external components. Conversely, it can be asserted low from the outside to reset the microcontroller core and the peripherals. The NRST pin integrates a permanent pull-up resistor of 100kΩ to VDDIO.

On the SAM4E-EK board, the NRST signal is connected to the LCD module and JTAG port.

Note: At power-on, the NRST signal is asserted with default duration of two clock cycles. This duration may not be sufficient to correctly reset any other system or board devices connected to the signal. First, in your custom application, you need to check for these devices' datasheets about reset duration requirements. Then, you need to set an appropriate configuration in the NRST Manager. This is done through the ERSTL field in the RSTC_MR register. The NRST duration is thereby configurable between 60μs and 2s, whether it is subsequently activated by a software reset or a user reset. Refer to the SAM4E16 datasheet for in-depth information.

4.3.5 Power Supply and Management

The Atmel SAM4E-EK board is supplied with an external 5V DC block through input J8. It is protected by a PolyZen diode (U3) and an LC combinatory filter (U4). The PolyZen is used in the event of an incorrect power supply connection.

The adjustable LDO regulator U5 is used for the 3.3V rail main supply. It powers all the 3.3V components on the board.

Figure 4-4. Power Block

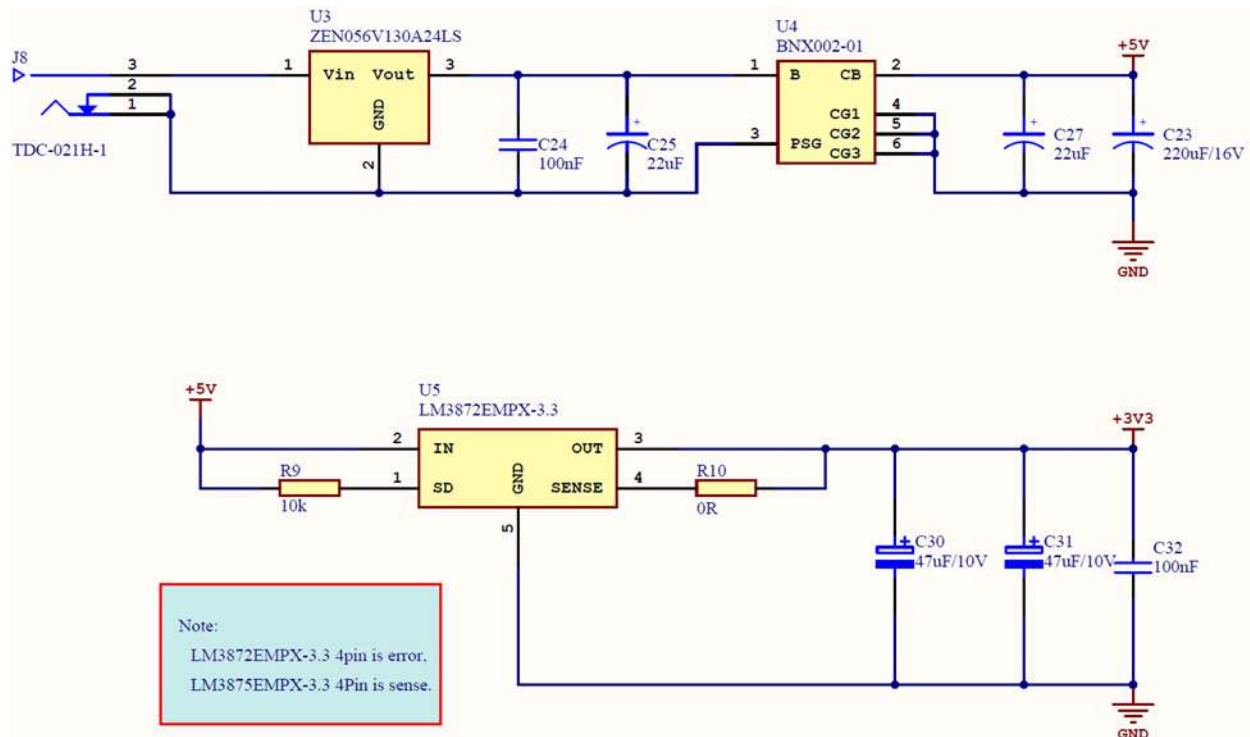

The SAM4E16 product has different types of power supply pins:

- VDDIN pin:
Power for the internal voltage regulator, ADC, DAC, and analog comparator power supplies.
The voltage ranges from 1.6 to 3.6V.
- VDDIO pins:
Power for the Peripherals I/O lines.
The voltage ranges from 1.62 to 3.6V.
- VDDOUT pin:
Output of the internal voltage regulator.
- VDDCORE pins:
Power for the core, including the processor, embedded memories, and peripherals.
The voltage ranges from 1.08 to 1.32V.
- VDDPLL pin:
Power for the PLL A, PLL B and 12MHz oscillator.
The voltage ranges from 1.08 to 1.32V.

Note: VDDPLL should be decoupled and filtered from VDDCORE.

4.3.6 UART

The Universal Asynchronous Receiver Transmitter (UART) features a two-pin UART that can be used for communication and trace purposes. It offers an ideal channel for in-situ programming solutions. This UART is associated with two PDC channels to reduce the processor time on packet handling.

This two-pin UART (TXD and RXD only) is buffered through an RS232 Transceiver U10 and brought to the DB9 male connector J20.

Figure 4-5. UART

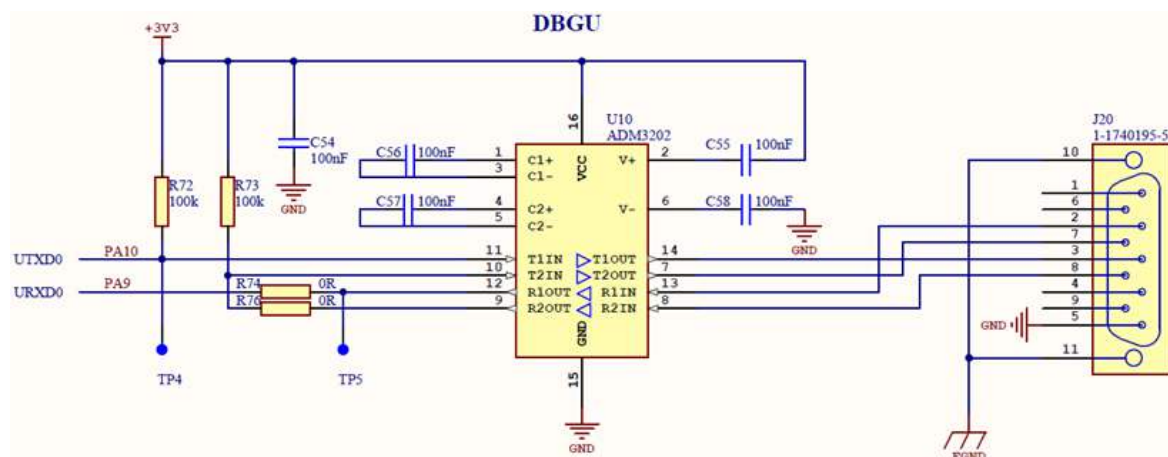

4.3.7 USART

The Universal Synchronous/Asynchronous Receiver Transmitter (USART) provides one full duplex universal synchronous/asynchronous serial link. The data frame format is extensively configurable (data length, parity, and number of stop bits) to support a broad range of serial communication standards. The USART is also associated with PDC channels for TX/RX data access.

To avoid any electrical conflict, the RS232 and RS485 transceiver are isolated from the receiving line PA21.

- Chose RS485 channel: Close 1-2 pins on J18 and set PA23 to high level
- Chose RS232 channel: Close 2-3 pins on J18 and set PA23 to low level

Figure 4-6. USART

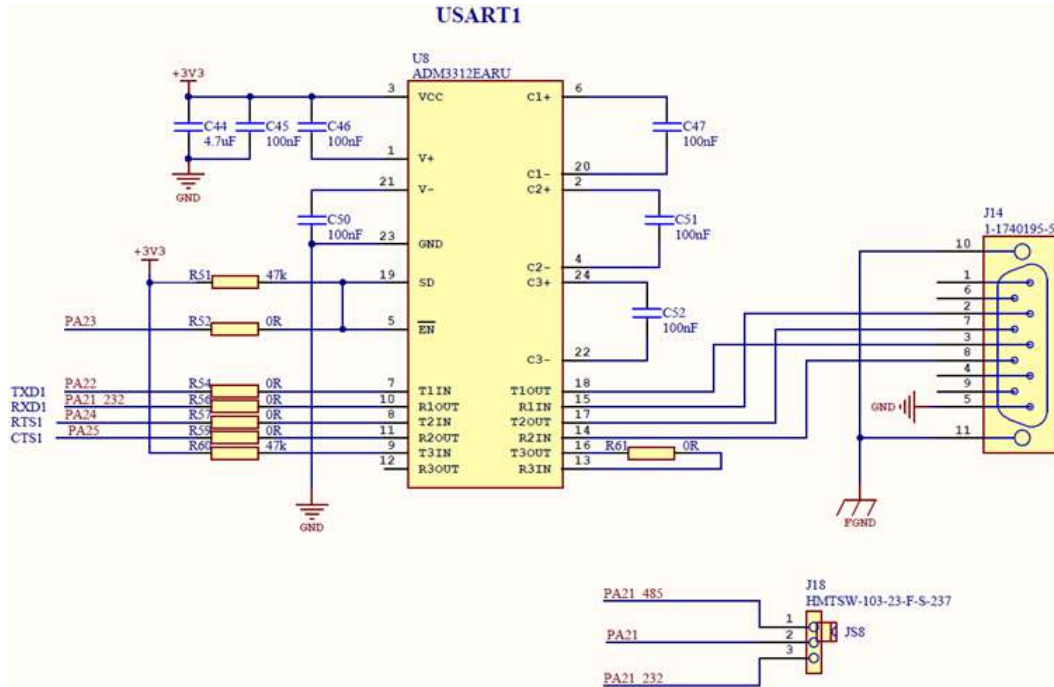

4.3.8 RS485

As noticed above the USART1 is shared with the RS485 port, connected to the transceiver U9 and output to the 3-point connector J16. The design includes selectable jumpers for RS485 bus termination resistors selection (J15, J17, and J19).

Figure 4-7. RS485

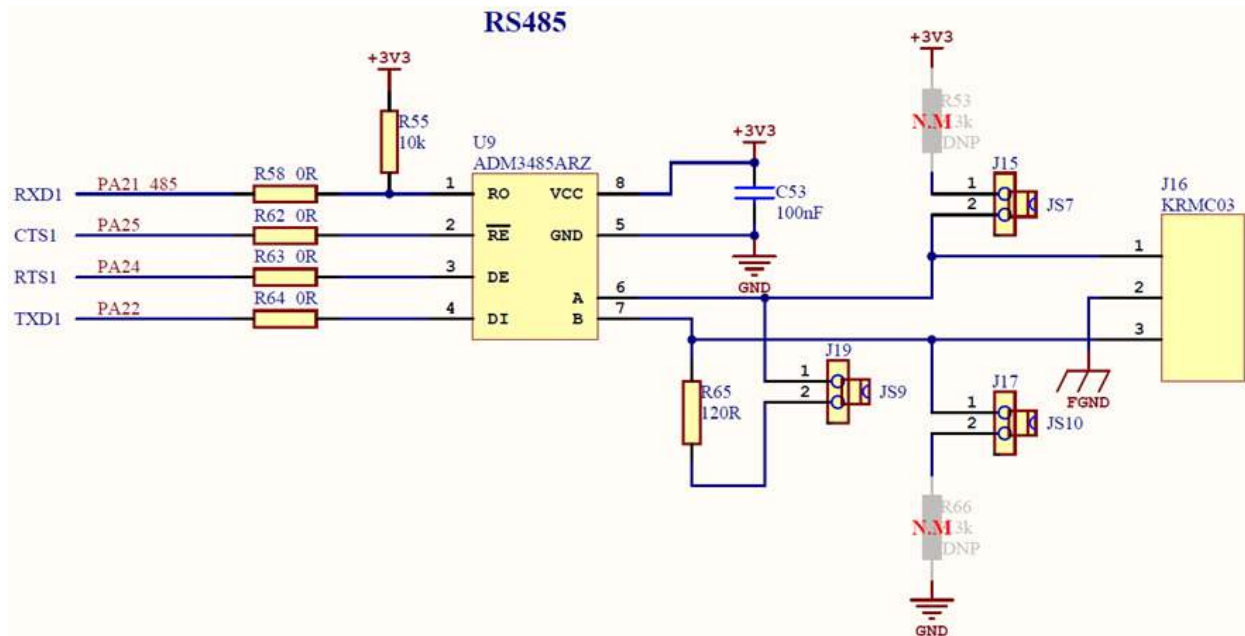

4.3.9 Ethernet MAC 10/100 (EMAC)

The EMAC module implements a 10/100 Ethernet MAC compatible with the IEEE® 802.3 standard using an address checker, statistics and control registers, receive and transmit blocks, and a DMA interface.

The Atmel SAM4E-EK is equipped with a MICREL KSZ8081MNX 10/100 Mbps Fast Ethernet Physical Layer transceiver. It contains the entire physical layer functions of 100BASE-TX as defined by IEEE 802.3u.

The Ethernet interface provides MII for 100Base-TX or 10Base-TX. The MII interfaces are capable of both 10Mb/s and 100Mb/s data rates as described in the IEEE 802.3u standard. The Ethernet interface integrates an RJ45 connector with an embedded transformer, and two status LEDs.

Figure 4-8. Ethernet Block

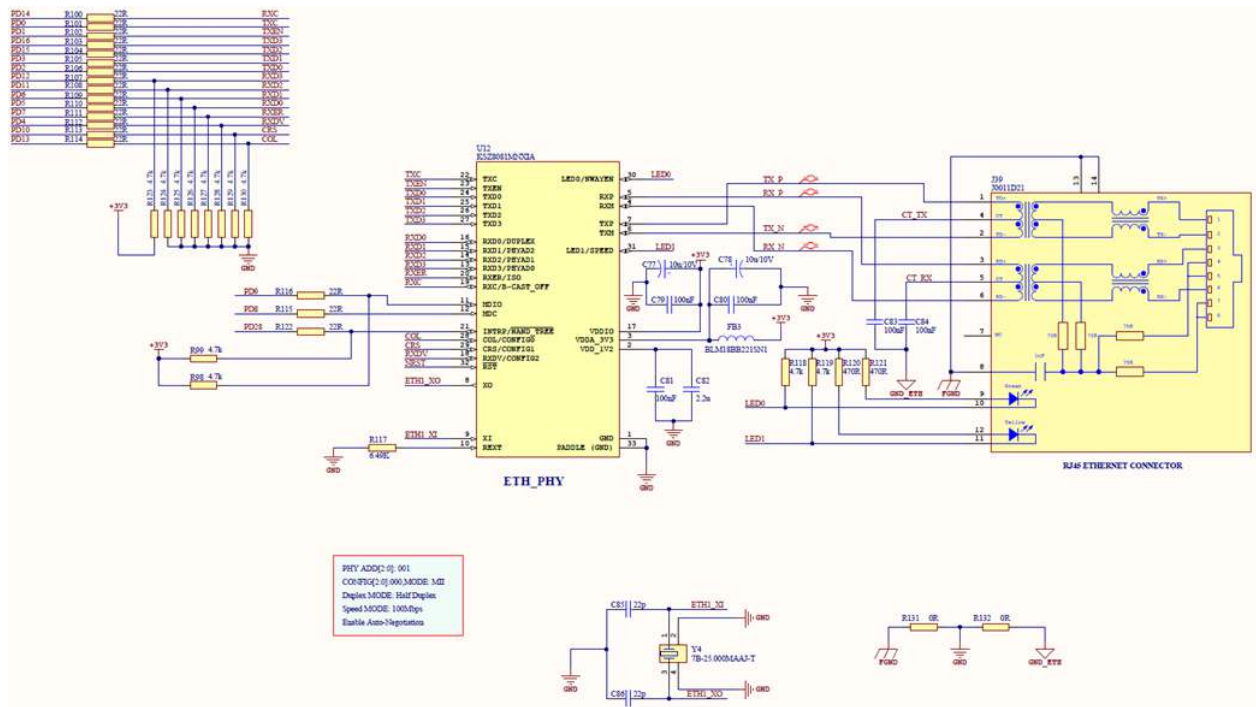

4.3.10 CAN

The CAN controller provides all the features required to implement the serial communication protocol CAN defined by Robert Bosch GmbH, the CAN specification as referred to by ISO/11898A (2.0 Part A and 2.0 Part B) for high speeds and ISO/11519-2 for low speeds. The CAN Controller is able to handle all types of frames (Data, Remote, Error and Overload) and achieves a bit rate of 1Mbit/sec.

The Atmel SAM4E has two CAN Controller with eight Mailboxes.

SAM4E-EK connects the CAN0 and CAN1 bus to the CAN transceiver SN65HVD234 (U15 and U17).

The extension connector (J41 and J44) type is RJ12 female socket.

Figure 4-9. CAN Block

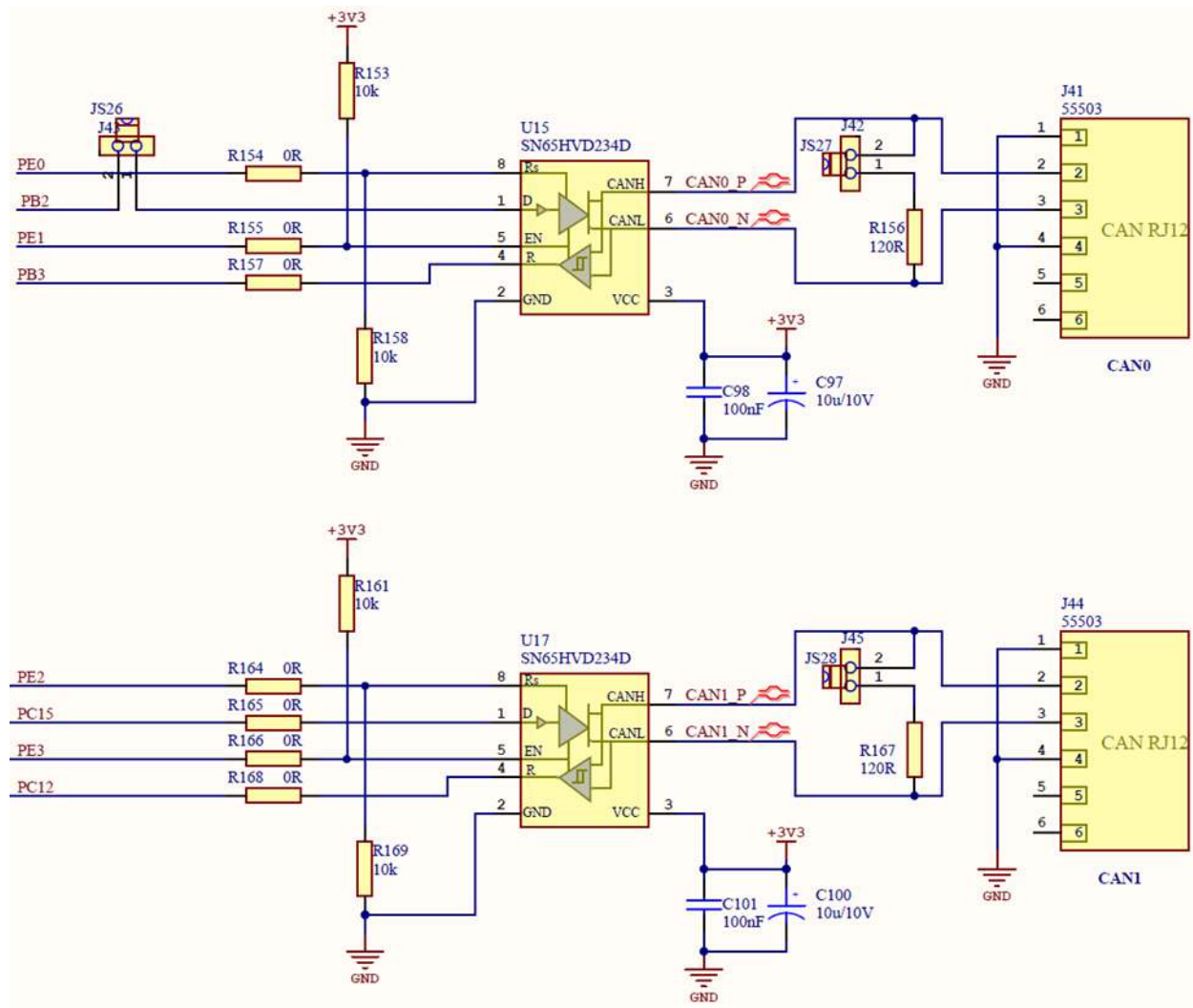

4.3.11 Display Interface

The SAM4E-EK carries a TFT transmissive LCD module with touch panel, FTM280C34D. Its integrated driver IC is ILI9325. The LCD display area is 2.8 inches diagonally measured, with a native resolution of 240 x 320 dots.

4.3.11.1 LCD Module

The LCD module gets reset from the NRST signal. As explained, this NRST is shared with the JTAG port and the push-button SW1. The LCD chip select signal is connected to NCS1; the jumper J11 can disconnect it so that this PIO line is available for other custom usage.

The SAM4E16 communicates with the LCD through PIOC where an 8-bit parallel “8080-like” protocol data bus has to be implemented in software.

Figure 4-10. LCD Block

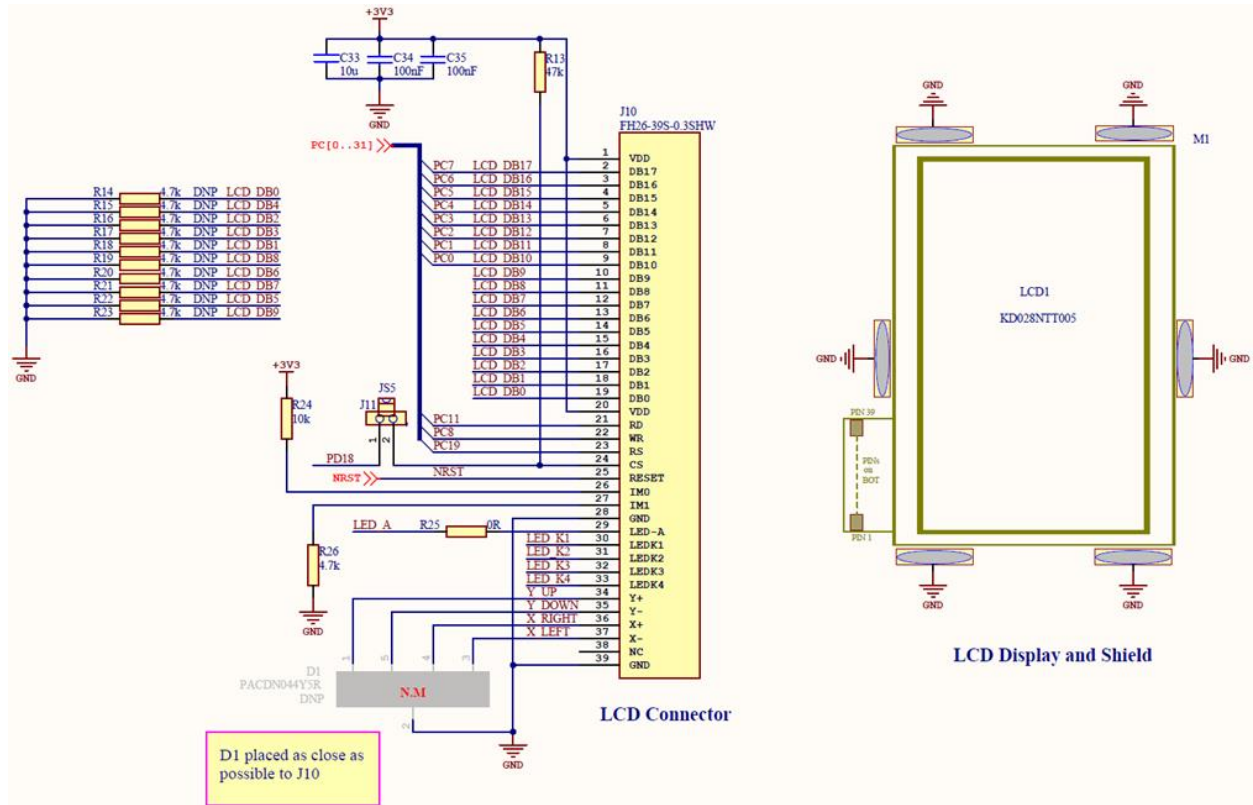

4.3.11.2 Backlight Control

The LCD backlight is made of four integrated white chip-LEDs arranged in parallel. These are driven by an AAT3155 charge pump, U7. The AAT3155 is controlled by PC13; the 0Ω resistor R37 is mounted in series on this line, which permits to use it for other custom purposes. In that case, the pull-up resistor R35 maintains the charge pump permanently enabled by default.

On the anode drive line, a 0Ω resistor R25 is implemented in series for an optional current limitation.

Figure 4-11. Backlight Control

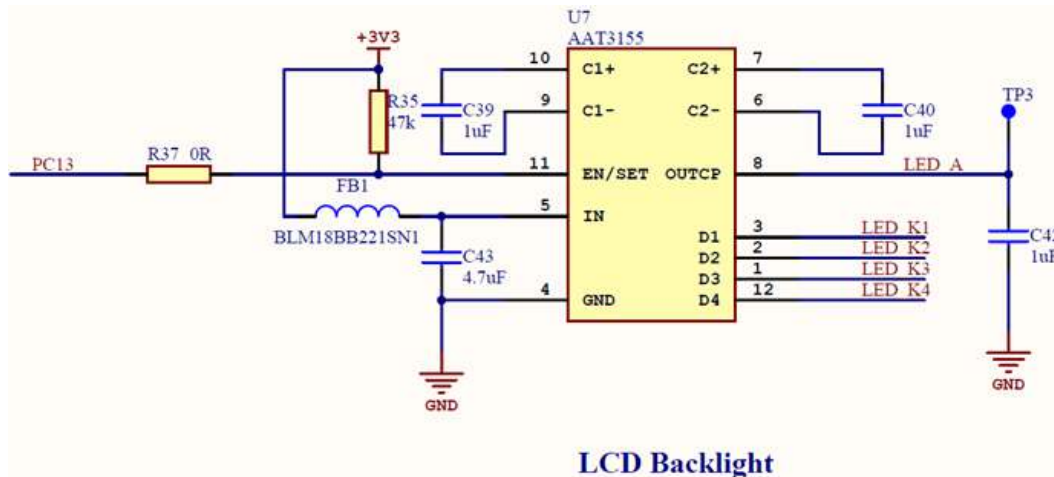

4.3.12 Touch Screen Interface

The LCD module integrates a 4-wire touch panel controlled by U6 (ADS7843), which is a slave device on the SAM4E16 SPI bus. The controller sends back the measurement information about the X and Y positions as a pressure is applied to the touch panel. The touch panel can be used with either a stylus or a finger.

The ADS7843 touch panel controller connects to the SPI interface via the NPCS0 control signal. Two interrupt signals are connected and provide events information back to the microcontroller: PenIrq and Busy.

Note: PenIrq (PA16) is shared with ZigBee signal ZIGB_MISC.

Busy (PA17) is shared with ZigBee signal ZIGB_IRQ.

Therefore, if using a ZigBee interface in concurrence with the Touch Screen controller, take care not to have both drivers enabled at the same time on either PA16 or PA17.

Figure 4-12. Touch Panel Control

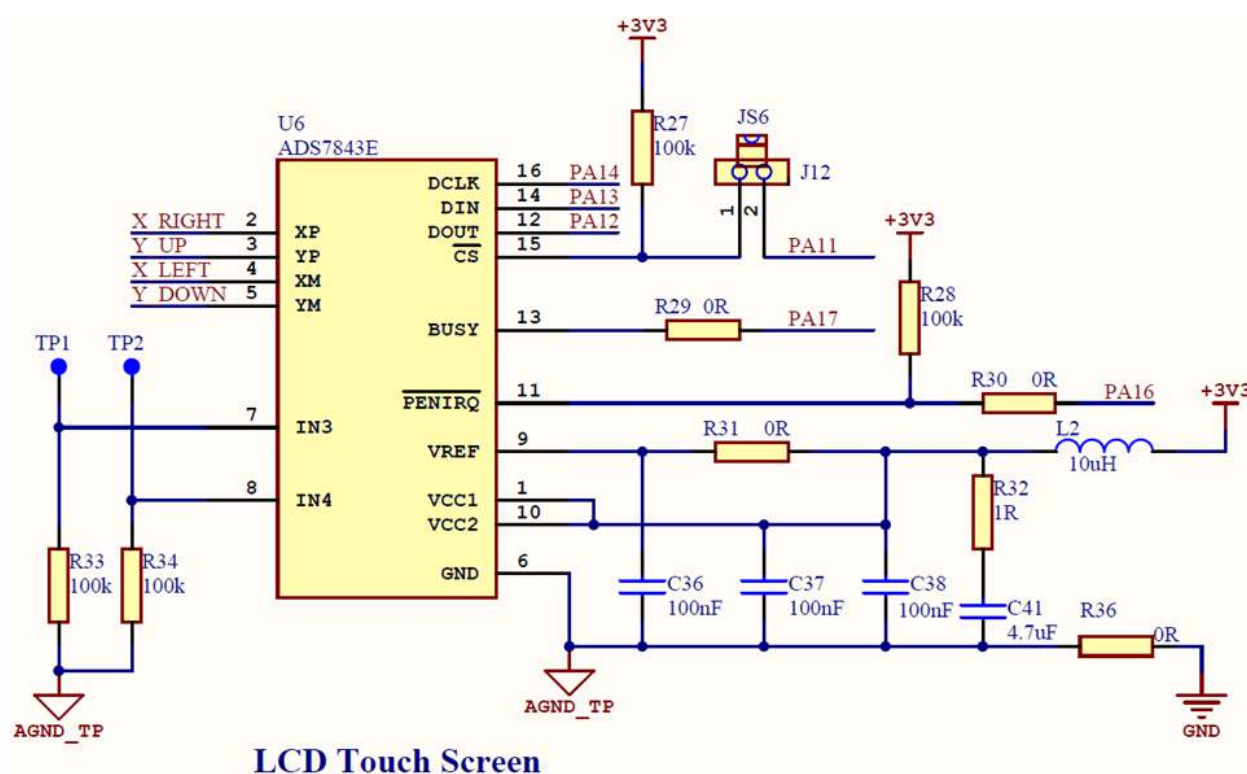

4.3.13 JTAG/ICE

A standard 20-pin JTAG/ICE connector is implemented on the Atmel SAM4E-EK for the connection of a compatible ARM JTAG emulator interface, such as the SAM-ICE™ from Segger.

Note that the NRST signal is connected to SW1 system button and is also used to reset the LCD module. The 0Ω resistor R75 may be removed in order to isolate the JTAG port from this system reset signal.

Figure 4-13. JTAG Interface

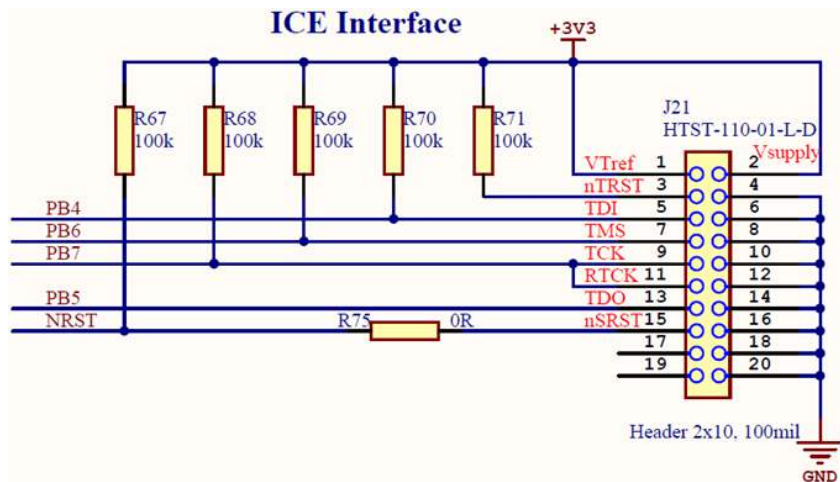

4.3.14 Audio Interface

The Atmel SAM4E-EK evaluation kit supports mono/stereo audio driven by a TPA0223 audio amplifier connected to two DAC channels of the microcontroller.

The TPA0223 is a 2W mono Bridge-Tied-Load (BTL) amplifier designed to drive speakers with as low as 4Ω impedance. The amplifier can be reconfigured on the fly to drive two stereo Single-Ended (SE) signals into head phones.

Figure 4-14. Headphone Output

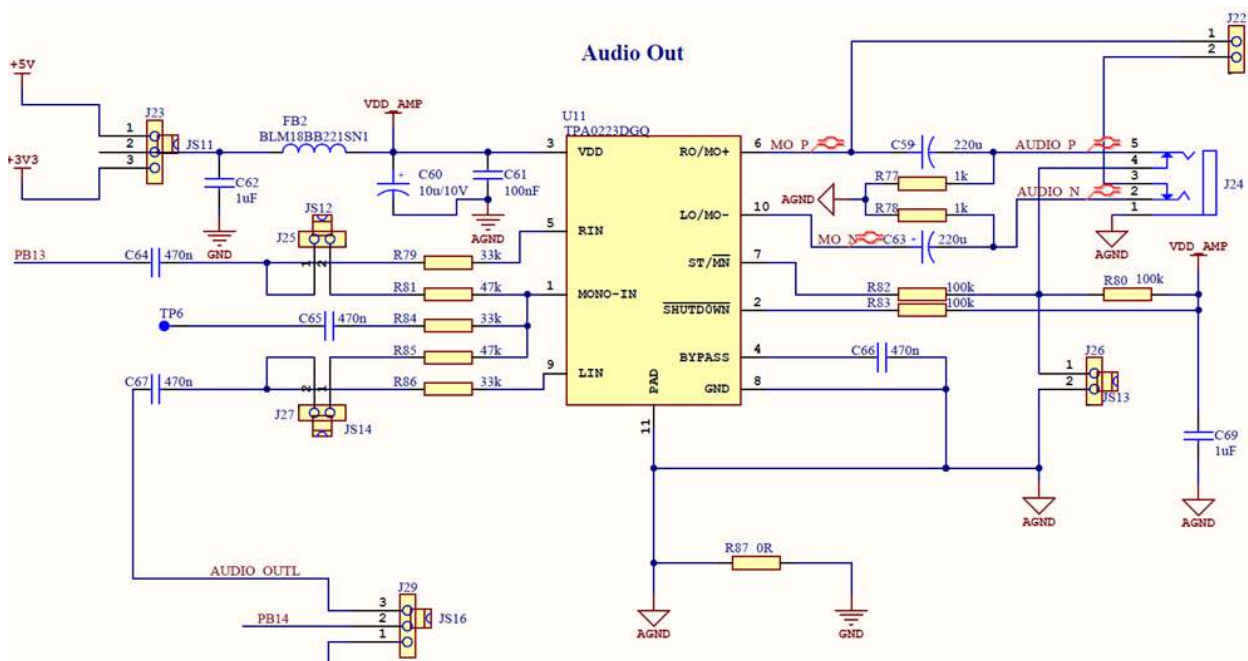

Using a readily available 1/8-in. (3.5mm) stereo headphone jack, the control switch (pin4 and pin5 in J24) is closed when no plug is inserted. When closed, a 100kΩ/1kΩ divider pulls the ST/MN input low. When a jack plug is inserted, the 1kΩ resistor is disconnected and the ST/MN input is pulled high. The mono speaker (J22 connector) is also physically disconnected from the RO/MO+ output so that no sound is heard from the speaker while the headphones are inserted.

When works as stereo mode make sure J25, J27, and J26 are disconnected.

4.3.15 USB Device

The SAM4E16 UDP port is compliant with the Universal Serial Bus (USB) rev 2.0 Full Speed device specification. J34 is a micro B-type receptacle for USB device.

Both 27Ω resistors R96 and R97 build up 90Ω differential impedance together with the (embedded) 6Ω output impedance of the SAM4E16 full speed channel drivers.

R93 and R94 build up a divider bridge from VBUS +5V to implement plug-in detection (5V level gets lowered to a PIO compatible 3.3V level) through PC21.

Figure 4-15. USB

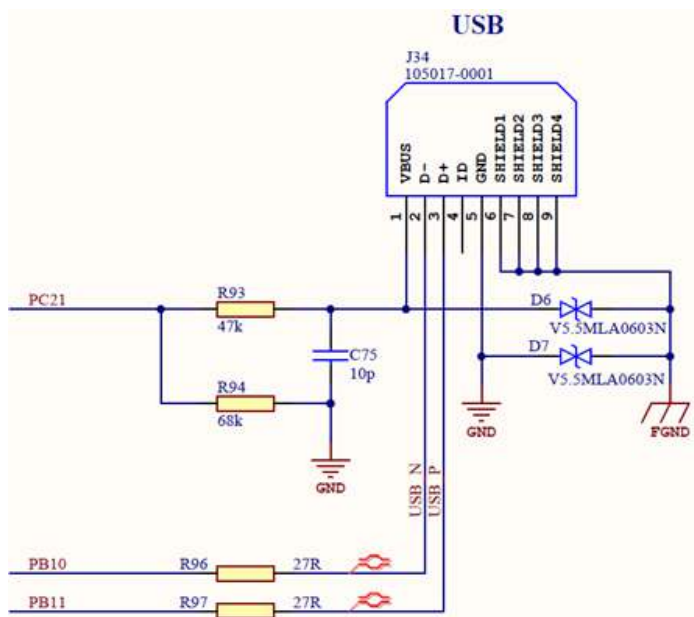

4.3.16 Analog Interface

4.3.16.1 Analog Reference

The 3.0V voltage reference is based on a LM4040 (Precision Micropower Shunt Voltage Reference). This ADVREF level can be set as 3.0V or 3.3V via the jumper J2.

Figure 4-16. Analog V_{REF}

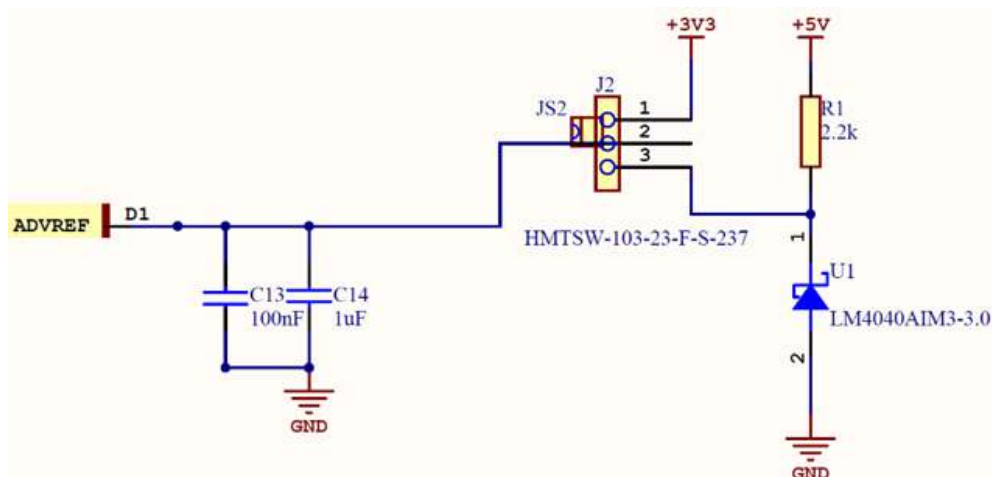

4.3.16.2 Analog Input

- The BNC connector CM1 is connected to the AEF0_AD4 or AFE1_AD0 (selected by JP40) as a single external analog input
- The BNC connectors CM3, CM4 are connected to AFE0_AD10 and AFE0_AD11 as a differential external analog input. A low pass filter is optional by close 1-2 pins of J32, J33, J36, and J37.
- Each BNC input has an on-board 50Ω resistor termination that can be applied by closing jumper J30, J35 or J38
- A 10kΩ potentiometer (VR1) is also connected to the AFE0_AD5 implement an easy access to ADC programming and debugging (or implement an analog user control like display brightness, volume, etc.)

Figure 4-17. ADC/AFE Input

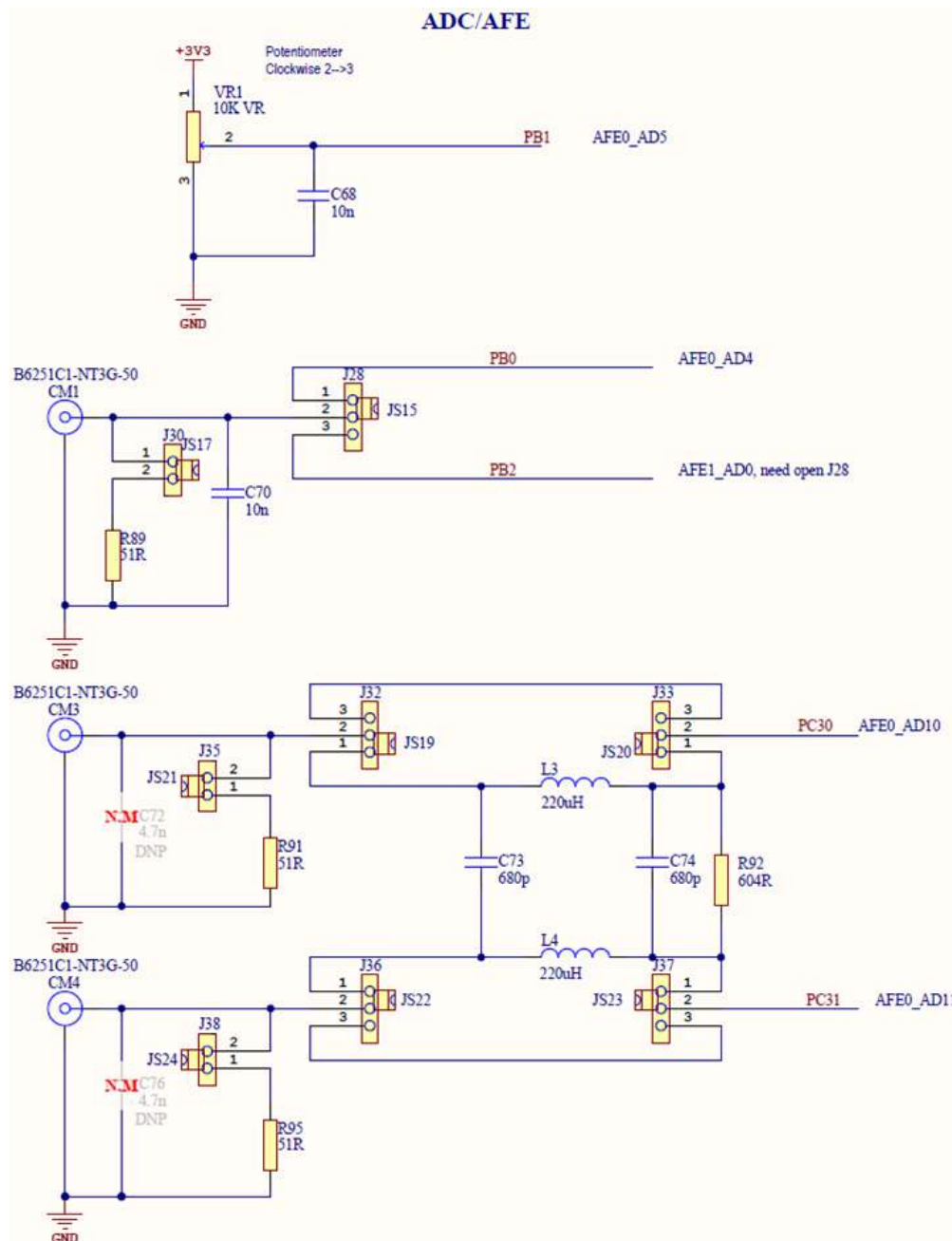

4.3.16.3 Analog Output

The BNC connector CM2 is connected to the DAC port PB14 and provides an external analog output. An on-board 50Ω resistor termination can be enabled by closing jumper J31. A filter can be implemented on this output channel by replacing R88 and C71 with appropriate resistor and capacitor values, depending on the application requirements.

Figure 4-18. DAC Output

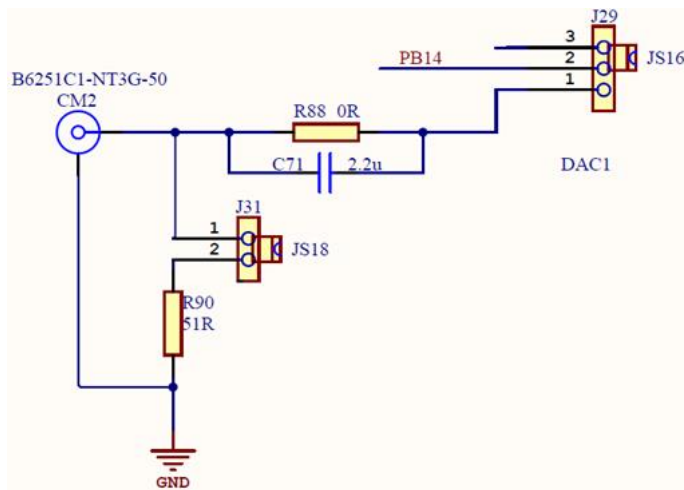

4.3.17 QTouch Elements

QTouch keys consist in a series of sensors formed by the association of a copper area and the capacitive effect of human fingers approaching it.

Keys

The Atmel SAM4E-EK implements two individual capacitive touch keys (RIGHT, LEFT).

Slider

A group of channels forms a Slider. A Slider is composed of eight channels for a QTouch acquisition method. Such a sensor is used to detect a linear finger displacement on a sensitive area. A typical implementation is volume control.

Figure 4-19. QT_Slider

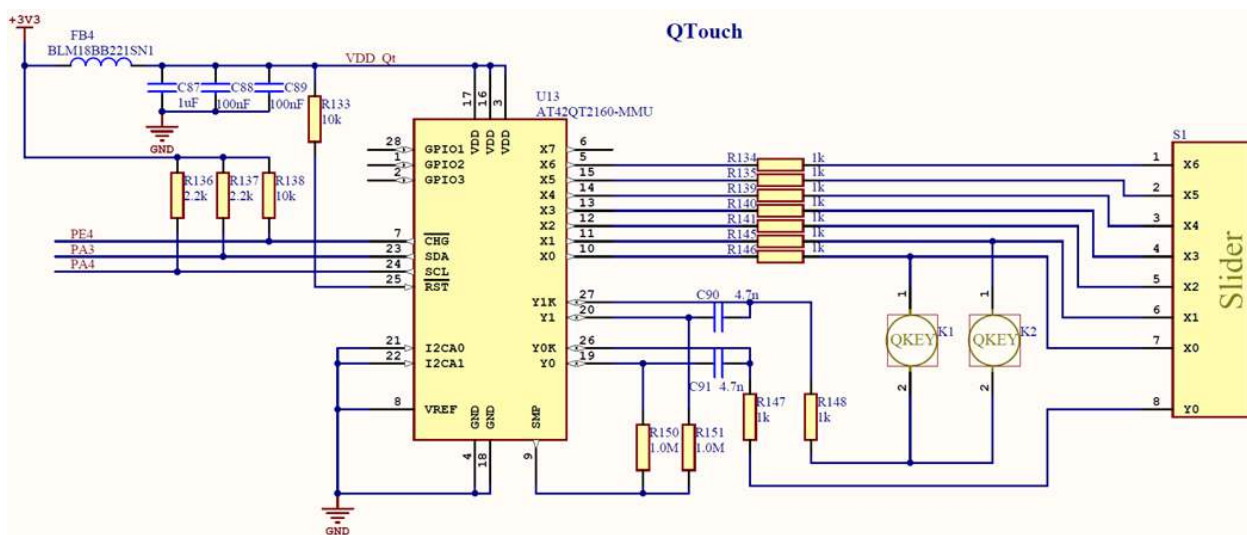

4.3.18 LEDs

There are three LEDs on the SAM4E-EK board:

- A blue LED (D2), amber/orange LED (D3) and a green LED (D4), which are user defined and controlled by the GPIO
- A red LED (D5), which is a power LED indicating that the 3.3V power rail is active. It is also controlled by the GPIO and can be treated as a user LED as well. The only difference with the two others is that it is controlled through a MOS transistor. By default, the PIO line is disabled; a pull-up resistor controls the MOS to light the LED when the power is ON.

Figure 4-20. LEDs

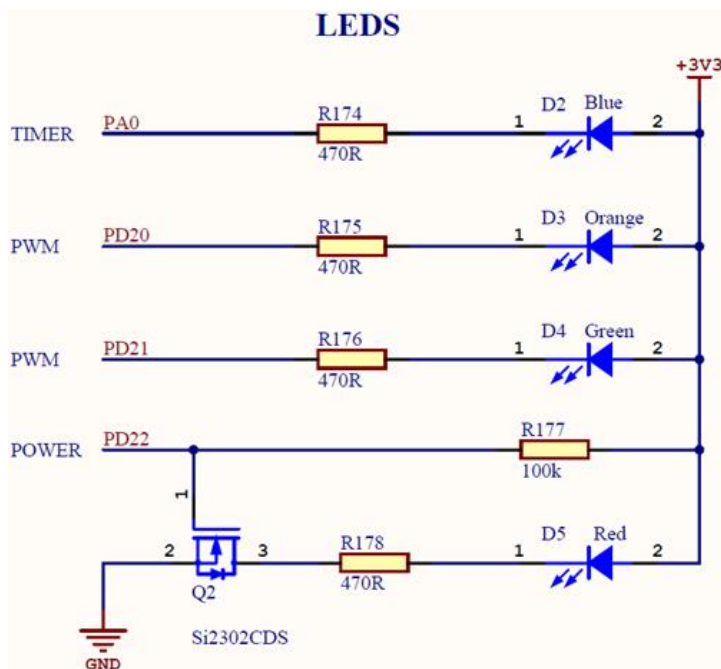

4.3.19 SD/MMC Card

The Atmel SAM4E-EK has a high-speed 4-bit multimedia MMC interface, which is connected to a 4-bit SD/MMC micro card slot featuring a card detection switch.

Figure 4-21. SD Card

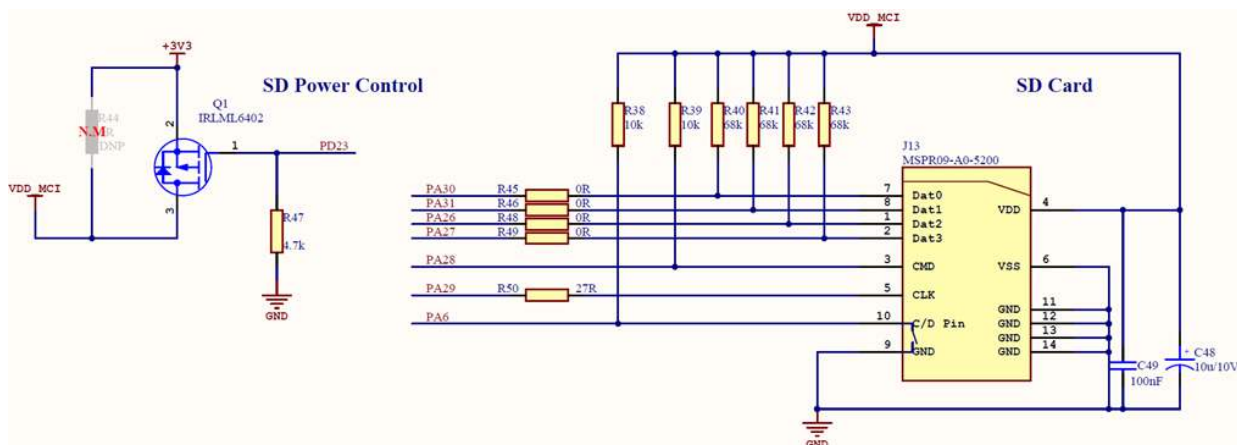

4.3.20 ZigBee

The SAM4E-EK has a 10-pin male connector for the RZ600 ZigBee module.

Note: 0Ω resistors have been implemented in series with the PIO lines that are used elsewhere in the design, thereby enabling their individual disconnection, should a conflict occur in your application.

Figure 4-22. ZigBee Interface

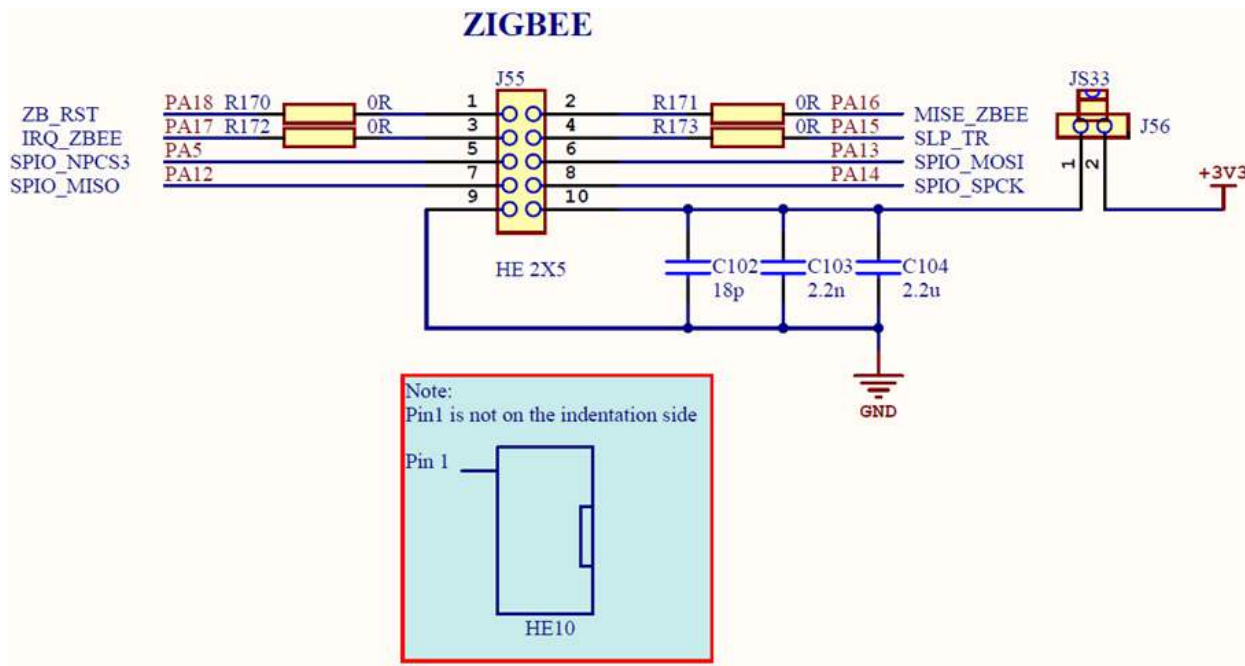

4.3.21 PIO Expansion

The SAM4E-EK product features three PIO controllers, PIOA, PIOB, PIOC, and PIOD, which are multiplexed with the I/O lines of the embedded peripherals. Each PIO Controller controls up to 32 lines (15 for PIOB and 6 for PIOE).

Expansion ports J51, J52, J53, and J54 provide PIO lines access for customer usage.

Figure 4-23. PIO Expansion

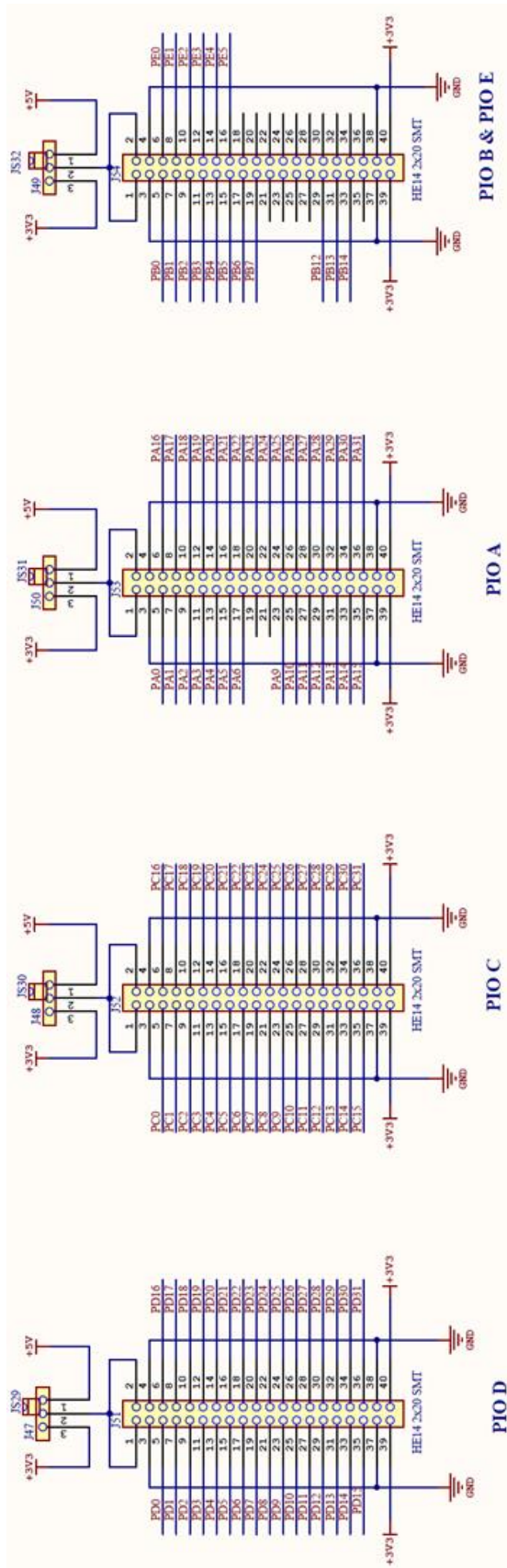

5 Configuration

This chapter describes the PIO usage, the jumpers, the test points and the solder drops of an Atmel SAM4E-EK board.

5.1 PIO Usage

Table 5-1. PIO Port A Pin Assignments and Signal Descriptions

I/O line	Peripheral A	Peripheral B	Peripheral C	Extra function	SYSIO and GPIO	Comments
PA0	PWMH0	TIOA0	A17	WKUP0		LED_TIMER (Blue)
PA1	PWMH1	TIOB0	A18	WKUP1		BUTTON_SCROLL-UP
PA2	PWMH2		DATRГ	WKUP2		BUTTON_SCROLL-DOWN
PA3	TWD0	NPCS3				QTouch_SDA
PA4	TWCK0	TCLK0		WKUP3		QTouch_SCL
PA5		NPCS3	URXD1	WKUP4		ZIGB_SEL#, SPI FLASH_CS#
PA6		PCK0	UTXD1			SD_CD
PA7		PWMH3			XIN32	XIN32
PA8		AFE0_ADTRG		WKUP5	XOUT32	XOUT32
PA9	URXD0	NPCS1	PWMFI0	WKUP6		DBGU_ROUT
PA10	UTXD0	NPCS2				DBGU_TIN
PA11	NPCS0	PWMH0		WKUP7		TOUCH_CS#
PA12	MISO	PWMH1				TOUCH_DOUT, ZIGB_MISO, SPI FLASH_SO
PA13	MOSI	PWMH2				TOUCH_DIN, ZIGB_MOSI, SPI FLASH_SI
PA14	SPCK	PWMH3		WKUP8		TOUCH_DCLK, ZIGB_SCLK, SPI FLASH_SCK
PA15		TIOA1	PWML3	WKUP14/PIODCEN1		ZIGB_SLP_TR
PA16		TIOB1	PWML2	WKUP15/PIODCEN2		TOUCH_PENIRQ#, ZIGB_MISC
PA17		PCK1	PWMH3	AFE0_AD0		TOUCH_BUZY, ZIGB_IRQ
PA18		PCK2	A14	AFE0_AD1		ZIGB_RST#
PA19		PWML0	A15	AFE0_AD2/WKUP9		BUTTON_WAKU
PA20		PWML1	A16	AFE0_AD3/WKUP10		BUTTON_TAMP
PA21	RXD1	PCK1		AFE1_AD2		RS232_RXD, RS485_RXD
PA22	TXD1	NPCS3	NCS2	AFE1_AD3		RS232_TXD, RS485_TXD
PA23	SCK1	PWMH0	A19	PIODCCLK		RS232_EN#
PA24	RTS1	PWMH1	A20	PIODC0		RS232_RTS, RS485_DE
PA25	CTS1	PWMH2	A23	PIODC1		RS232_CTS, RS485_RE#
PA26	DCD1	TIOA2	MCDA2	PIODC2		SD_DAT2
PA27	DTR1	TIOB2	MCDA3	PIODC3		SD_DAT3
PA28	DSR1	TCLK1	MCCDA	PIODC4		SD_CMD
PA29	RI1	TCLK2	MCCK	PIODC5		SD_CLK
PA30	PWML2	NPCS2	MCDA0	WKUP11/PIODC6		SD_DAT0
PA31	NPCS1	PCK2	MCDA1	PIODC7		SD_DAT1

Table 5-2. PIO Port B Pin Assignments and Signal Descriptions

I/O line	Peripheral A	Peripheral B	Peripheral C	Extra function	SYSIO and GPIO	Comments
PB0	PWMH0		RXD0	AFE0_AD4/RTCOUT0		AFE0_BNC
PB1	PWMH1		TXD0	AFE0_AD5/RTCOUT1		ADC_Potentiometer
PB2	CANTX0	NCPS2	CTS0	AFE1_AD0/WKUP12		CAN0_D, AFE1_BNC
PB3	CANRX0	PCK2	RTS0	AFE1_AD1		CAN0_R
PB4	TWD1	PWMH2			TDI	JTAG_TDI
PB5	TWCK1	PWML0		WKUP13	TDO/TRACESWO	JTAG_TDO
PB6					TMS/SWDIO	JTAG_TMS
PB7					TCK/SWCLK	JTAG_TCK
PB8					XOUT	XOUT
PB9					XIN	XIN
PB10					DDP	USB_D+
PB11					DDM	USB_D-
PB12	PWML1				ERASE	ERASE
PB13	PWML2	PCK0	SCK0	DAC0		AUDIO_RIN
PB14	NPXS1	PWMH3		DAC1		AUDIO_LIN, DAC1_BNC

Table 5-3. PIO Port C Pin Assignments and Signal Descriptions

I/O line	Peripheral A	Peripheral B	Peripheral C	Peripheral D	Extra function	SYSIO and GPIO	Comments
PC0	D0	PWML0			AFE0_AD14		NAND_D0/LCD_DB10
PC1	D1	PWML1			AFE1_AD4		NAND_D1/LCD_DB11
PC2	D2	PWML2			AFE1_AD5		NAND_D2/LCD_DB12
PC3	D3	PWML3			AFE1_AD6		NAND_D3/LCD_DB13
PC4	D4	NPXS1			AFE1_AD7		NAND_D4/LCD_DB14
PC5	D5	TIOA6					NAND_D5/LCD_DB15
PC6	D6	TIOB6					NAND_D6/LCD_DB16
PC7	D7	TCLK6					NAND_D7/LCD_DB17
PC8	NWE	TIOA7					LCD_WR
PC9	NANDOE	TIOB7					NAND_OE#
PC10	NANDWE	TCLK7					NAND_WE#
PC11	NRD	TIOA8					LCD_RD
PC12	NCS3	TIOB8	CANRX1		AFE0_AD8		CAN1_R
PC13	NWAIT	PWML0			AFE0_AD6		LCDBL_EN/SET
PC14	NCS0	TCLK8					NAND_CE#
PC15	NCS1	PWML1	CANTX1		AFE0_AD7		CAN1_D
PC16	A21/NANDALE						NAND_ALE
PC17	A22/NANDCLE						NAND_CLE
PC18	A0	PWMH0					NAND_R/B#
PC19	A1	PWMH1					LCD_RS

PC20	A2	PWMH2					
PC21	A3	PWMH3					USB_VBUS
PC22	A4	PWML3					
PC23	A5	TIOA3					
PC24	A6	TIOB3					
PC25	A7	TCLK3					
PC26	A8	TIOA4			AFE0_AD12		
PC27	A9	TIOB4			AFE0_AD13		
PC28	A10	TCLK4					
PC29	A11	TIOA5			AFE0_AD9		
PC30	A12	TIOB5			AFE0_AD10		AFE0_BNC
PC31	A13	TCLK5			AFE0_AD11		AFE0_BNC

Table 5-4. PIO Port D Pin Assignments and Signal Descriptions

I/O line	Peripheral A	Peripheral B	Peripheral C	Peripheral D	Extra function	SYSIO and GPIO	Comments
PD0	GTXCK/GREFCK						MII_TXCK
PD1	GTXEN						MII_TXEN
PD2	GTX0						MII_TX0
PD3	GTX1						MII_TX1
PD4	GCRSDV/GRXDV						MII_RXDV
PD5	GRX0						MII_RX0
PD6	GRX1						MII_RX1
PD7	GRXER						MII_RXER
PD8	GMDC						ETH_MDC
PD9	GMDIO						ETH_MDIO
PD10	GCRS						MII_CRS
PD11	GRX2						MII_RX2
PD12	GRX3						MII_RX3
PD13	GCOL						MII_COL
PD14	GRXCK						MII_RXCK
PD15	GTX2						MII_TX2
PD16	GTX3						MII_TX3
PD17	GTXER						
PD18	NCS1						LCD_CS
PD19	NCS3						
PD20	PWMH0						LED_PWM (Amber)
PD21	PWMH1						LED_PWM (Green)
PD22	PWMH2						LED_PWR (RED)
PD23	PWMH3						SD_PWR_CTL

PD24	PWML0						
PD25	PWML1						
PD26	PWML2						
PD27	PWML3						
PD28							ETH_INTR
PD29							
PD30							
PD31							

Table 5-5. PIO Port E Pin Assignments and Signal Descriptions

I/O line	Peripheral A	Peripheral B	Peripheral C	Peripheral D	Extra function	SYSIO and GPIO	Comments
PE0							CAN0_Rs
PE1							CAN0_EN
PE2							CAN1_Rs
PE3							CAN1_EN
PE4							QTouch_CHANGE#

5.2 Jumpers

The Atmel SAM4E-EK board jumpers are essentially used for two main purposes: functional selection or current measurement. Details are given below.

Table 5-6. 2-pin Jumpers Setting

Name	Signal	Close	Open
J46	SPI FLASH_CS (NPCS3)	Connect (default)	Disconnect
J40	NAND_CE# (NCS0)	Connect (default)	Disconnect
J4	VDDCORE	Connect (default)	Disconnect
J1	VDDIO	Connect (default)	Disconnect
J3	VDDIN	Connect (default)	Disconnect
J43	CANTX0	CANTX0 can use	AFE1_AD0 can use
J7	ERASE	Erase internal flash	Default
J12	TOUCH_CS# (NPCS0)	Connect (default)	Disconnect
J11	LCD_CS (NCS1)	Connect (default)	Disconnect
J59	BUTTON_SCROLL-UP	Connect (default)	Disconnect
J60	BUTTON_SCROLL-DOWN	Connect (default)	Disconnect
J58	BUTTON_TAMP	Connect (default)	Disconnect
J57	BUTTON_WAKU	Connect (default)	Disconnect
J25	PB13(DAC) to MONO-IN (Audio)	Connect (default)	Disconnect (default)
J27	PB14(DAC) to MONO-IN (Audio)	Connect (default)	Disconnect (default)

J26	Audio_ST/MN#	Force mono mode	No force (default)
J30, J31, J35	BNC input 50Ω match resister	Use	No use (default)

Name	Signal	1-2 close	2-3 close
J18	PA21	RS485-RX	RS232-RX
J2	ADVREF	3.3V (default)	3.0V
J23	Audio power	5V (default)	3.3V
J29	DAC_PB14	To CN1 (BNC)	To Audio_LIN (default)
J47, J48, J49, J50	PIOA/B/C/D-CONN-power	5V	3.3V
J32, J33, J36, J37	AFE0_AD10/AD11	Use filter(default)	Bypass filter
J28	ADC BNC input	To AFE0_AD4	To AFE1_AD0

6 Schematics

This chapter contains the following schematics:

- Block diagram
- Microcontroller
- TFT-LCD and touch
- COM and SD card and JTAG
- Audio and USB
- Ethernet
- QTouch, CAN, and Flash memories
- I/O Peripheral

Figure 6-1. Block Diagram

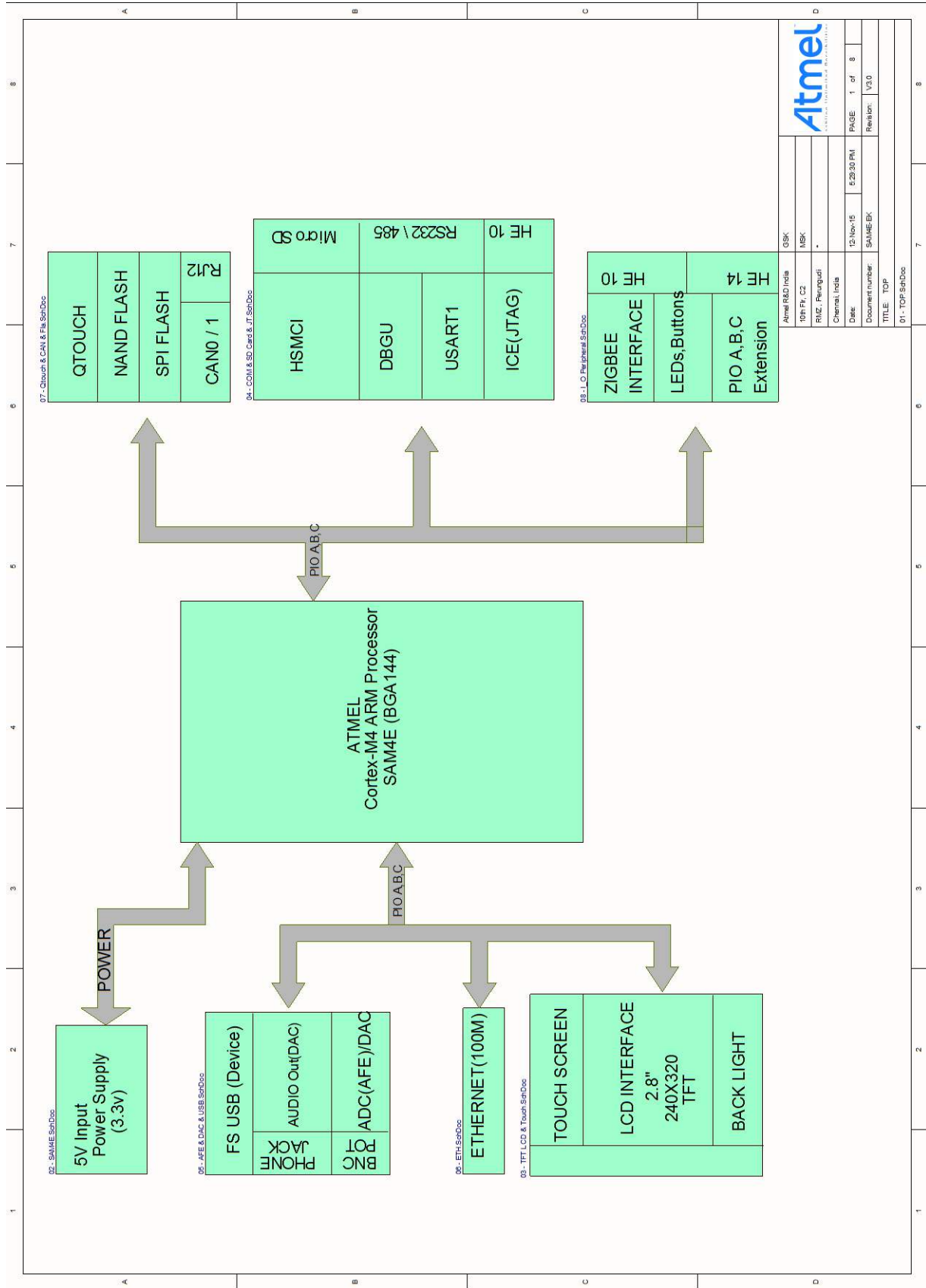
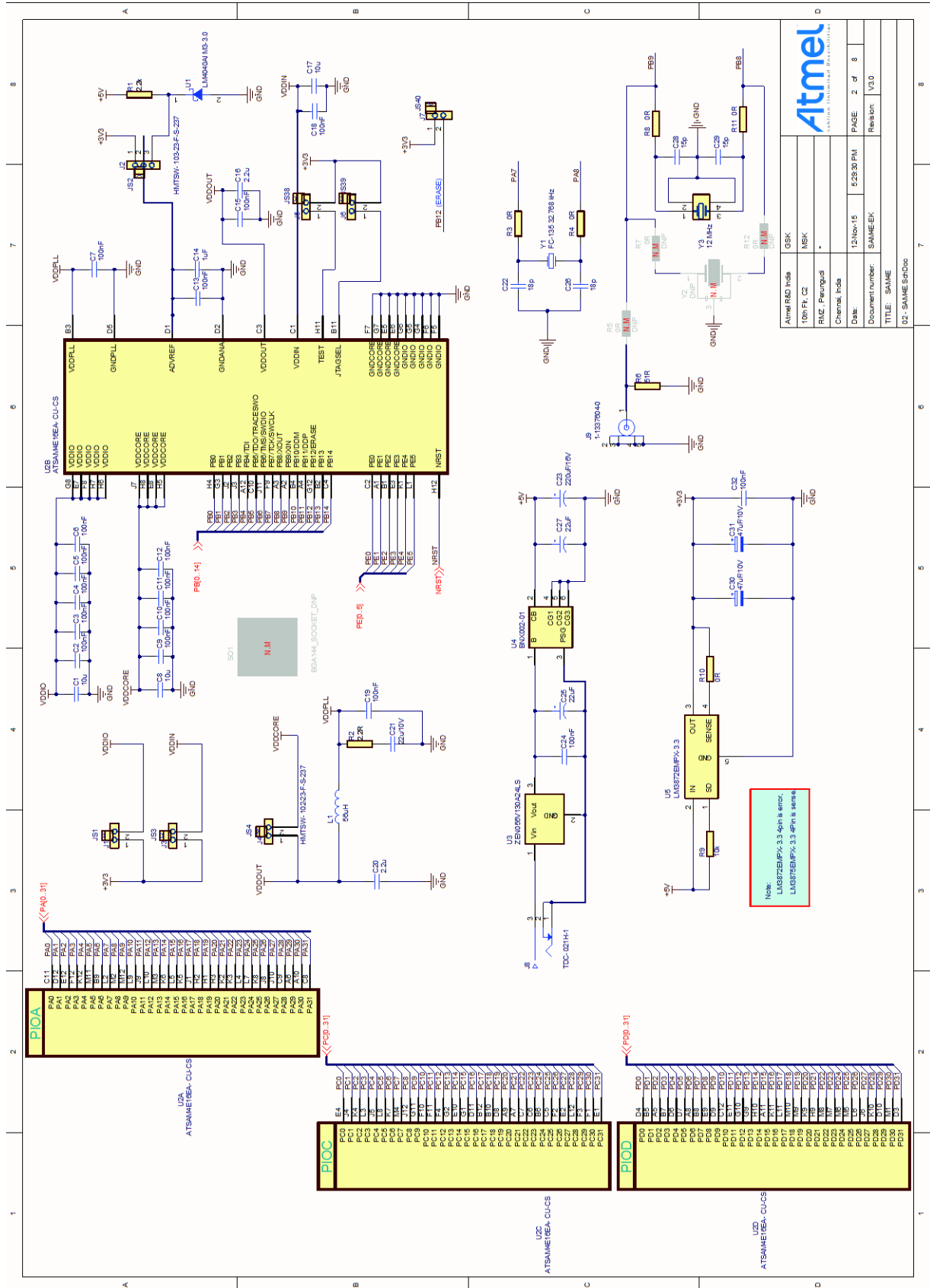

Figure 6-2. Microcontroller



Atmel R4D Inds	GSK
10h P1, C2	MSK
RMZ_Peungud	-
Chemel Inds	-
Date:	12-Nov-15
Document number:	SAMEEK
TITLE:	SAME
02 - SAME8rDoc	

Note:
LMB87ZEMPX-3.3 4pin is sense.

Figure 6-3. TFT-LCD and Touch

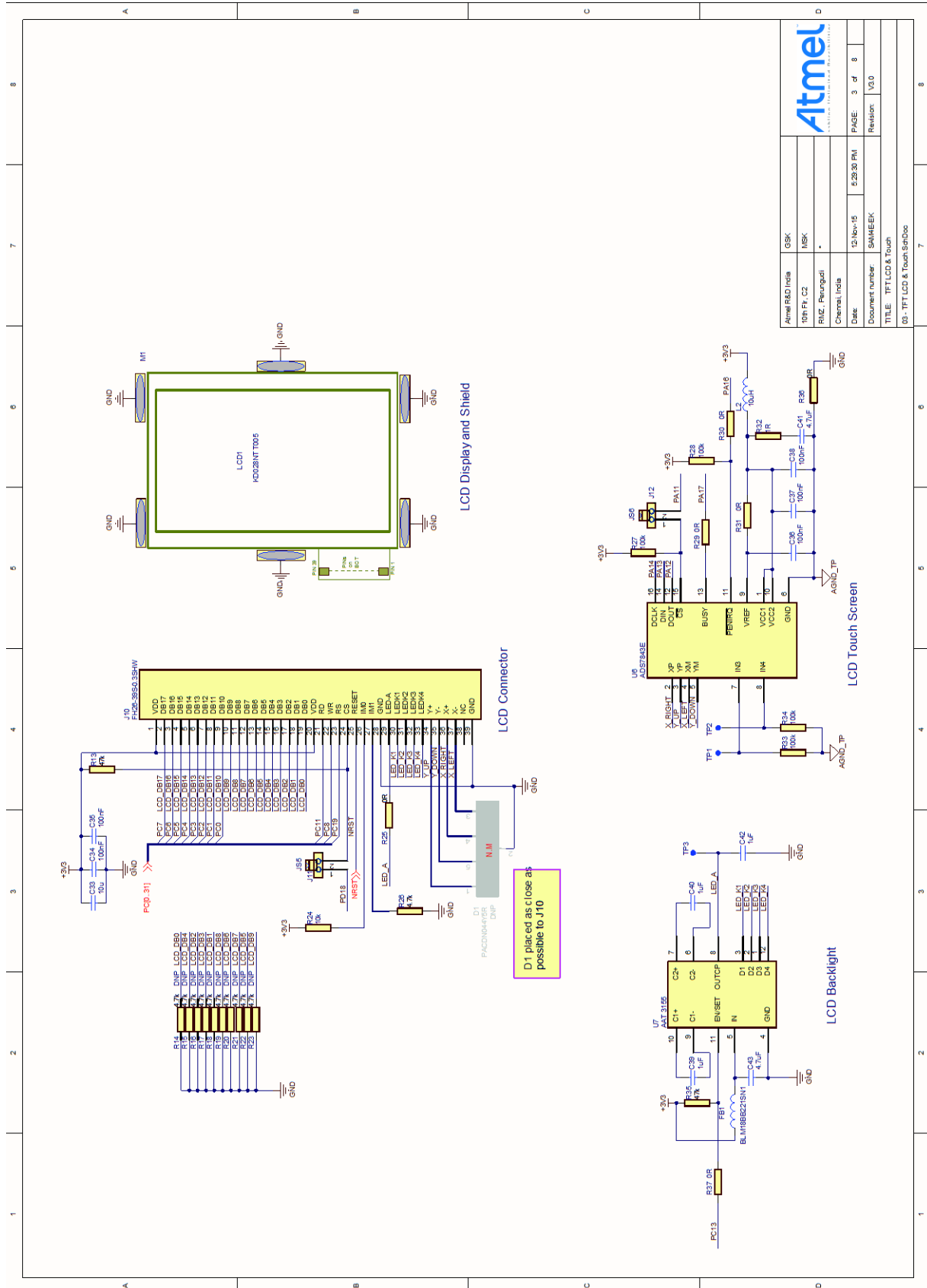

Figure 6-4. COM and SD Card and JTAG

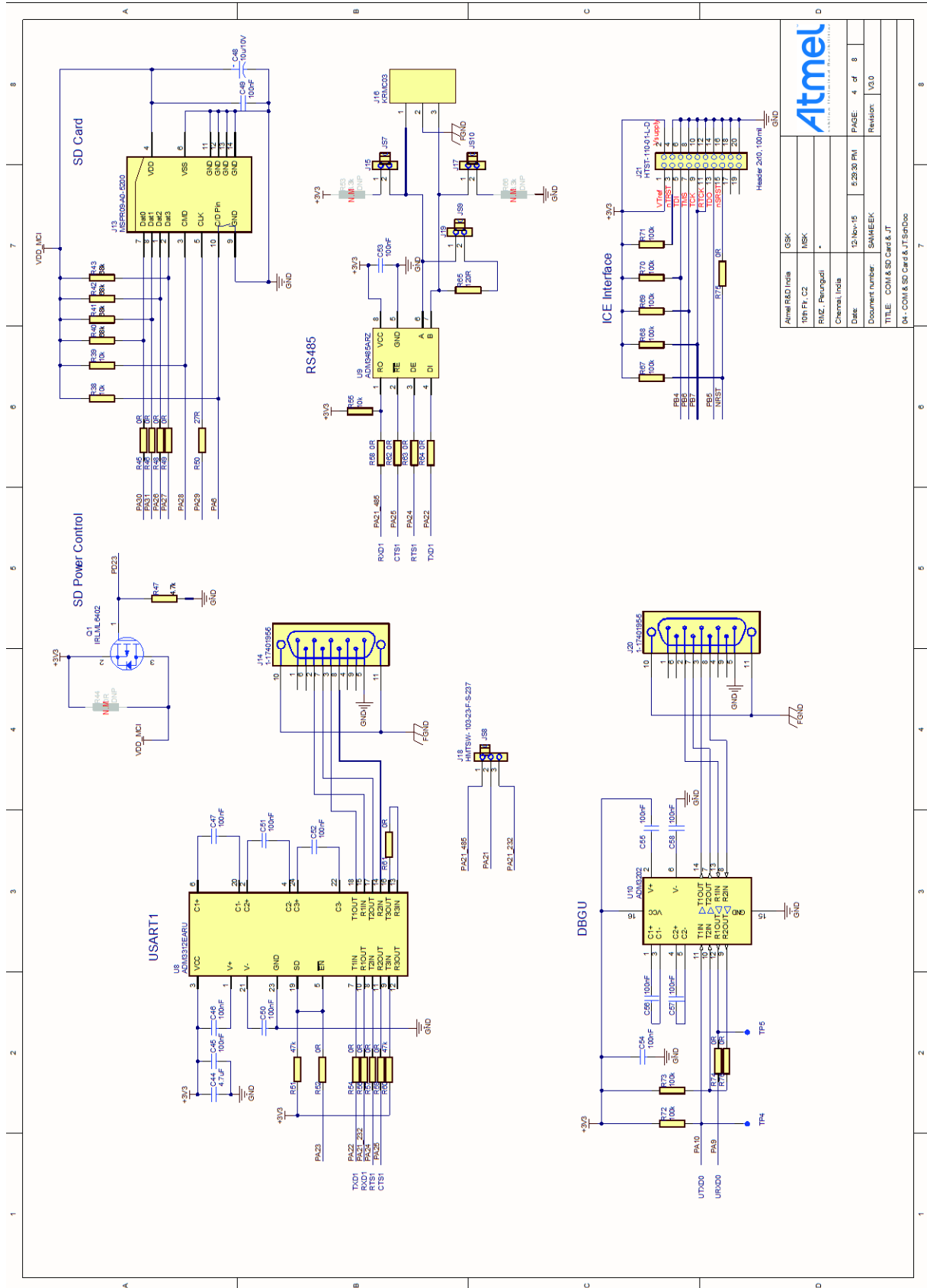
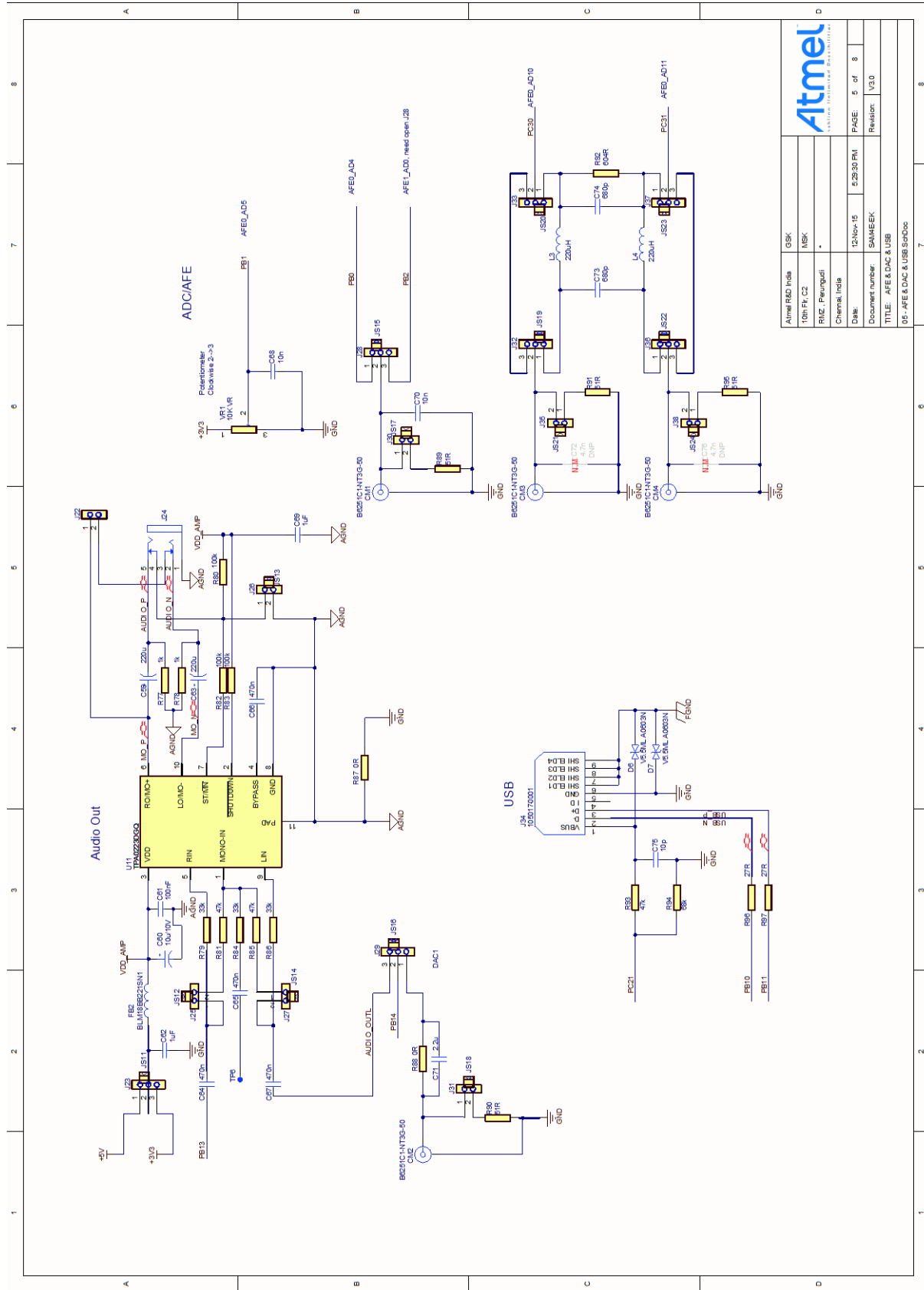

Figure 6-5. Audio and USB



Atmel R&D India	GSK
100% FR C2	MSK
RIC, Pune/Goa	
Chennai, India	
Date:	13-Nov-15 5:29:30 PM
Document number:	SAM4E-EK
TITLE:	AFE & DAC & USB
Revision:	V2.0
05- AFE & DAC & USB S900c	

Figure 6-6. Ethernet

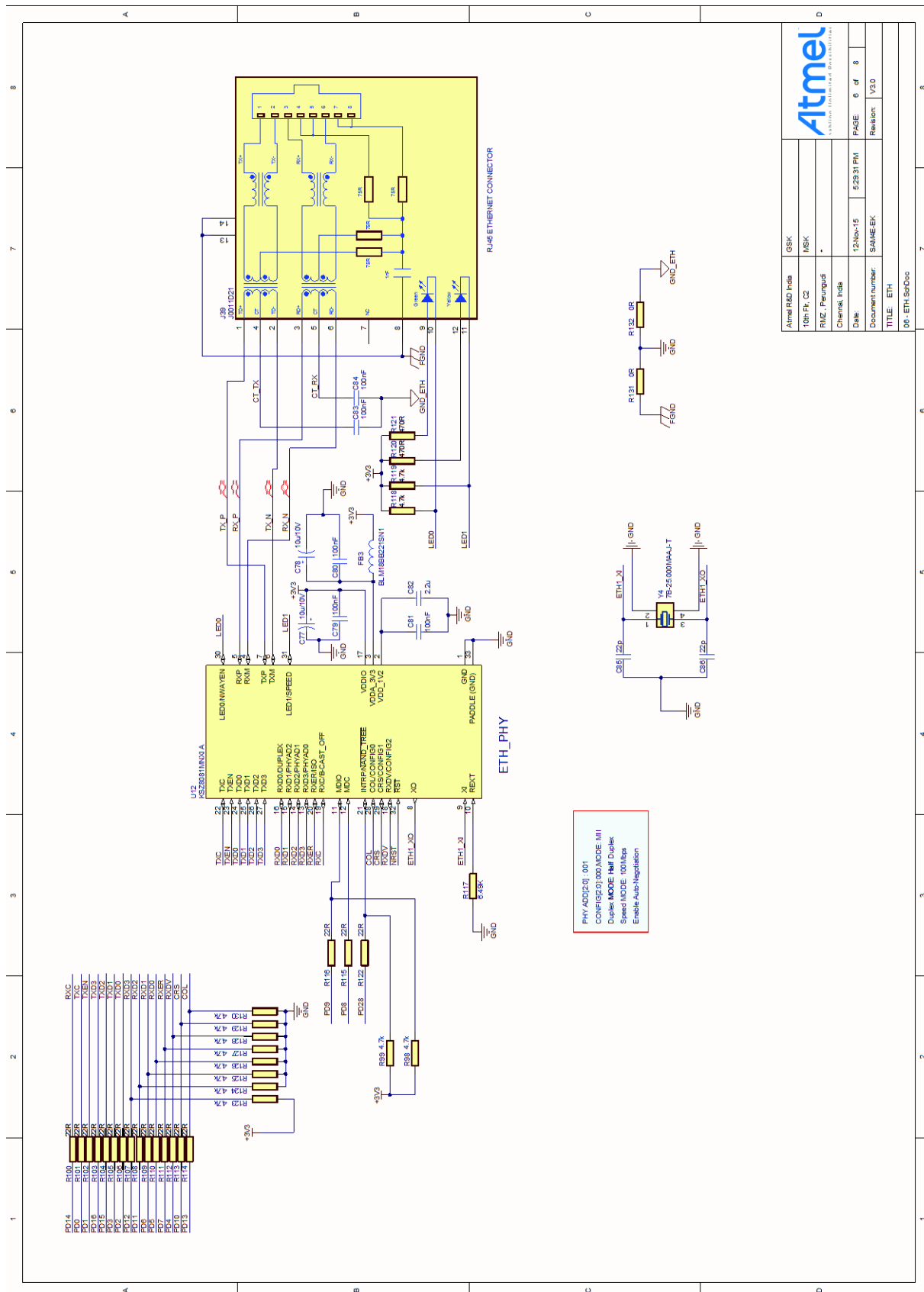
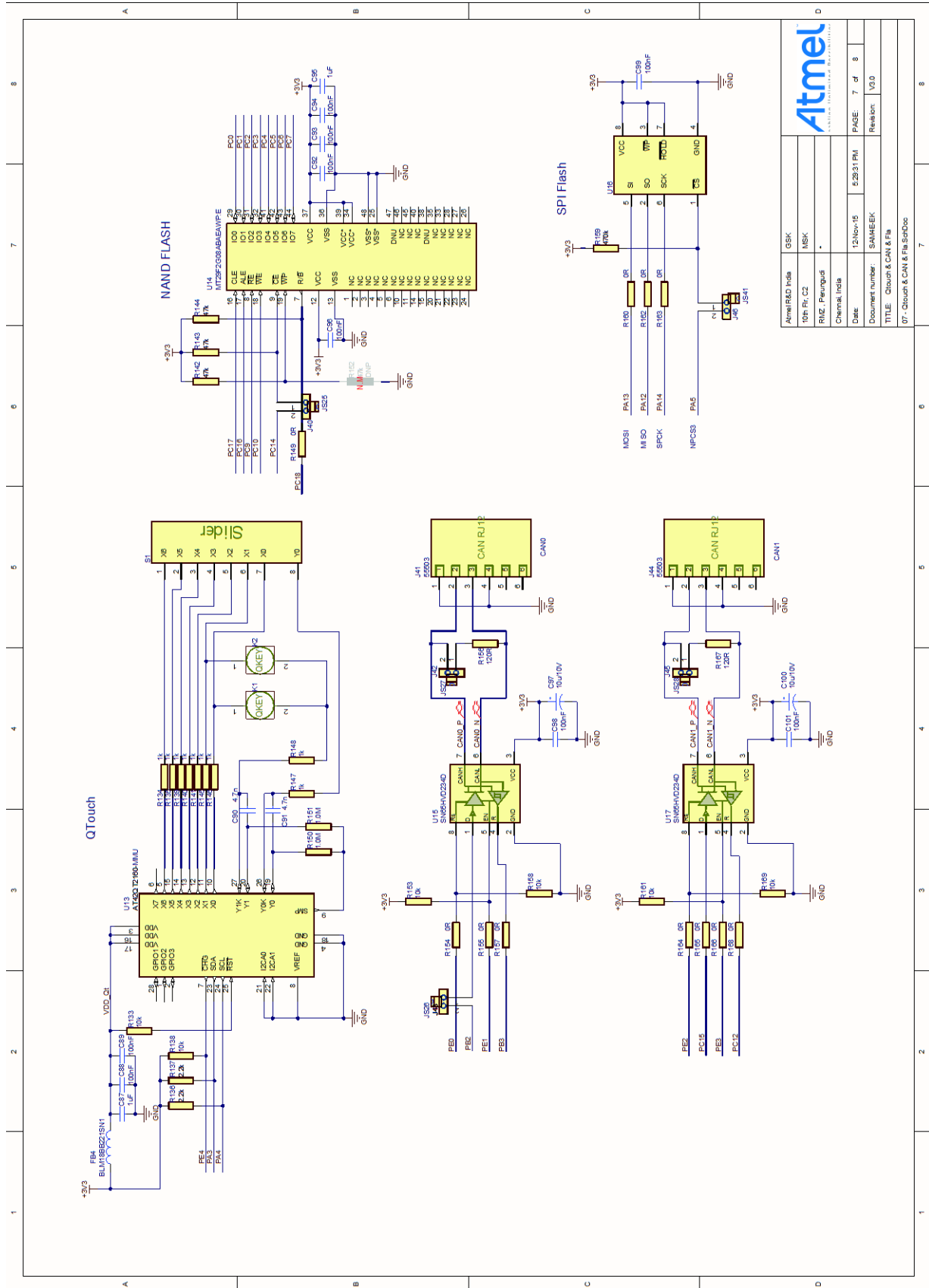

Figure 6-7. QTouch, CAN, and Flash Memories



7 ATMEL EVALUATION BOARD/KIT IMPORTANT NOTICE AND DISCLAIMER

This evaluation board/kit is intended for user's internal development and evaluation purposes only. It is not a finished product and may not comply with technical or legal requirements that are applicable to finished products, including, without limitation, directives or regulations relating to electromagnetic compatibility, recycling (WEEE), FCC, CE or UL. Atmel is providing this evaluation board/kit "AS IS" without any warranties or indemnities. The user assumes all responsibility and liability for handling and use of the evaluation board/kit including, without limitation, the responsibility to take any and all appropriate precautions with regard to electrostatic discharge and other technical issues. User indemnifies Atmel from any claim arising from user's handling or use of this evaluation board/kit. Except for the limited purpose of internal development and evaluation as specified above, no license, express or implied, by estoppel or otherwise, to any Atmel intellectual property right is granted hereunder. ATMEL SHALL NOT BE LIABLE FOR ANY INDIRECT, SPECIAL, INCIDENTAL, OR CONSEQUENTIAL DAMAGES RELATING TO USE OF THIS EVALUATION BOARD/KIT.

ATMEL CORPORATION
1600 Technology Drive
San Jose, CA 95110
USA

8 Revision History

Doc Rev.	Date	Comments
42067C	02/2016	Updated to incorporate the changes latest revision of the kit. Some minor changes according to the template.
42067B	04/2013	A feature is added to the feature list in Chapter 0. Some typos are fixed.
42067A	01/2013	Initial document release.



Atmel® | Enabling Unlimited Possibilities®



Atmel Corporation 1600 Technology Drive, San Jose, CA 95110 USA **T:** (+1)(408) 441.0311 **F:** (+1)(408) 436.4200 | **www.atmel.com**

© 2016 Atmel Corporation. / Rev.: Atmel-42067C-SAM4E-EK_UserGuide_022016.

Atmel®, Atmel logo and combinations thereof, Enabling Unlimited Possibilities®, QTouch®, and others are registered trademarks or trademarks of Atmel Corporation in U.S. and other countries. ARM®, ARM Connected® logo, and others are the registered trademarks or trademarks of ARM Ltd. Other terms and product names may be trademarks of others.

DISCLAIMER: The information in this document is provided in connection with Atmel products. No license, express or implied, by estoppel or otherwise, to any intellectual property right is granted by this document or in connection with the sale of Atmel products. EXCEPT AS SET FORTH IN THE ATMEL TERMS AND CONDITIONS OF SALES LOCATED ON THE ATMEL WEBSITE, ATMEL ASSUMES NO LIABILITY WHATSOEVER AND DISCLAIMS ANY EXPRESS, IMPLIED OR STATUTORY WARRANTY RELATING TO ITS PRODUCTS INCLUDING, BUT NOT LIMITED TO, THE IMPLIED WARRANTY OF MERCHANTABILITY, FITNESS FOR A PARTICULAR PURPOSE, OR NON-INFRINGEMENT. IN NO EVENT SHALL ATMEL BE LIABLE FOR ANY DIRECT, INDIRECT, CONSEQUENTIAL, PUNITIVE, SPECIAL OR INCIDENTAL DAMAGES (INCLUDING, WITHOUT LIMITATION, DAMAGES FOR LOSS AND PROFITS, BUSINESS INTERRUPTION, OR LOSS OF INFORMATION) ARISING OUT OF THE USE OR INABILITY TO USE THIS DOCUMENT, EVEN IF ATMEL HAS BEEN ADVISED OF THE POSSIBILITY OF SUCH DAMAGES. Atmel makes no representations or warranties with respect to the accuracy or completeness of the contents of this document and reserves the right to make changes to specifications and products descriptions at any time without notice. Atmel does not make any commitment to update the information contained herein. Unless specifically provided otherwise, Atmel products are not suitable for, and shall not be used in, automotive applications. Atmel products are not intended, authorized, or warranted for use as components in applications intended to support or sustain life.

SAFETY-CRITICAL, MILITARY, AND AUTOMOTIVE APPLICATIONS DISCLAIMER: Atmel products are not designed for and will not be used in connection with any applications where the failure of such products would reasonably be expected to result in significant personal injury or death ("Safety-Critical Applications") without an Atmel officer's specific written consent. Safety-Critical Applications include, without limitation, life support devices and systems, equipment or systems for the operation of nuclear facilities and weapons systems. Atmel products are not designed nor intended for use in military or aerospace applications or environments unless specifically designated by Atmel as military-grade. Atmel products are not designed nor intended for use in automotive applications unless specifically designated by Atmel as automotive-grade.