

## LS010B7DH01 Memory LCD Module

### Product Specification

December 2010

Normally White, transfective 128 × 128 Module features Octagonal Shape, Individual Pixel Memory, Very Low Power use, Serial Interface, FPC connection, extended temperature operation; contrast of 14:1, 0.25% transmissivity, and 17% reflectivity.

PREPARED BY: DATE T. Wakai : 3 Dec. 2010	<div style="text-align: center;"> <h1>SHARP</h1> <p>LIQUID CRYSTAL DISPLAY GROUP SHARP CORPORATION</p> <h2>SPECIFICATION</h2> </div>	SPEC No.      LCP-2110042B
APPROVED BY: DATE Y. Hataguchi : 3 Dec. 2010		FILE No.
		ISSUE                      3 Dec. 2010
		PAGE                      Pages 27
		APPLICABLE DIVISION  ENGINEERING DEPARTMENT I  LCD DIVISION II  LCD GROUP

DEVICE SPECIFICATION for  
TFT LCD Module

Model No.  
**LS010B7DH01**

CUSTOMER'S APPROVAL

DATE \_\_\_\_\_

BY \_\_\_\_\_

PRESENTED BY *F. Kinoshita*

FUMIO KINOSHITA

DEPARTMENT GENERAL MANAGER  
ENGINEERING DEPARTMENT I  
LCD DIVISION II  
LCD GROUP  
SHARP CORPORATION



## NOTICE

This publication is the proprietary of SHARP and is copyrighted, with all rights reserved. Under the copyright laws, no part of this publication may be reproduced or transmitted in any form or by any means, electronic or mechanical for any purpose, in whole or in part, without the express written permission of SHARP. Express written permission is also required before any use of this publication may be made by a third party.

The application circuit examples in this publication are provided to explain the representative applications of SHARP's devices and are not intended to guarantee any circuit design or permit any industrial property right or other rights to be executed. SHARP takes no responsibility for any problems related to any industrial property right or a third party resulting from the use of SHARP's devices, except for those resulting directly from device manufacturing processes.

In the absence of confirmation by device specification sheets, SHARP takes no responsibility for any defects that occur in equipment using any of SHARP's devices, shown in catalogs, data books, etc. Contact SHARP in order to obtain the latest device specification sheets before using any SHARP's device.

SHARP reserves the right to make changes in the specifications, characteristics, data, materials, structures and other contents described herein at any time without notice in order to improve design or reliability. Contact SHARP in order to obtain the latest specification sheets before using any SHARP's device. Manufacturing locations are also subject to change without notice.

Observe the following points when using any device in this publication. SHARP takes no responsibility for damage caused by improper use of the devices.

The devices in this publication are designed for use in general electronic equipment designs, such as:

- Personal computers
- Office automation
- Telecommunication equipment
- Test and measurement equipment
- Industrial control
- Personal digital assistant
- Audio visual and multimedia equipment
- Consumer electronics
- Watch

The appropriate design measures should be taken to ensure reliability and safety when SHARP's devices are used for equipment such as:

- Transportation control and safety equipment (i.e., aircraft, trains, automobiles, etc.)
- Traffic signals
- Gas leakage sensor breakers
- Alarm equipment
- Various safety devices etc.

SHARP's devices shall not be used for equipment that requires extremely high level of reliability, such as:

- Military and space applications
- Nuclear power control equipment
- Medical equipment for life support

Contact a SHARP representative, in advance, when intending to use SHARP's devices for any "specific" applications other than those recommended by SHARP.

Contact and consult with a SHARP representative if there are any questions about the contents of this publication.

## 1. Applicable scope

This specification is applicable to TFT-LCD Module “LS010B7DH01” only.

## 2. General description

This module is a monochrome transfective and active matrix LCD module incorporating CG-Silicon TFT (Continuous Grain-Silicon Thin Film Transistor). It is composed of a monochrome TFT-LCD panel with 1 bit memory and FPC.

Graphics and texts can be displayed on a 128×128 dots panel by super low power consumptions.

## 3. Mechanical (physical) specifications

Table 1

Item	Specifications	Unit
Screen size	Ø25.024 (0.99" type) diameter	mm
Active area	Ø25.024 diameter	mm
Pixel format	128(H)×128(V)	dots
Pixel pitch	0.1955(H) × 0.1955(V)	mm
Pixel configuration	Stripe	
Display mode	Normally white	
Unit outline dimensions	33.0(W)×33.4(H)×1.64(D)	mm
Mass	Approx 3.7	g
Surface hardness	3H	
Surface treatment	AG	

[Note 3-1] The above-mentioned table indicates module sizes without some projections and FPC.

For detailed measurements and tolerances, please refer to Figure 23.

4. Input terminal names and functions

4-1. LCD-FPC

Table 2

#	symbol	I/O	Function	Remark
1	SCLK	I	Serial clock signal	
2	SI	I	Serial data input signal	
3	SCS	I	Chip select signal	
4	EXTCOMIN	I	External COM inversion signal input (H: enable)	
5	DISP	I	Display on/off signal	Note 4-1
6	VDDA	-	Power supply (Analog)	
7	VDD	-	Power supply (Digital)	
8	EXTMODE	I	COM inversion select terminal	Note 4-2
9	VSS	-	GND (Digital)	
10	VSSA	-	GND (Analog)	

[Note 4-1] The display on/off signal is only for display. Data memory will be saved also at the time of on/off.

"H": data memory will be displayed.

"L": white color will be displayed and data memory will be saved.

[Note 4-2] "H": enable EXTCOMIN signal, connect to VDD.

"L": enable serial input flag, connect to VSS.

4-2. Recommended circuit

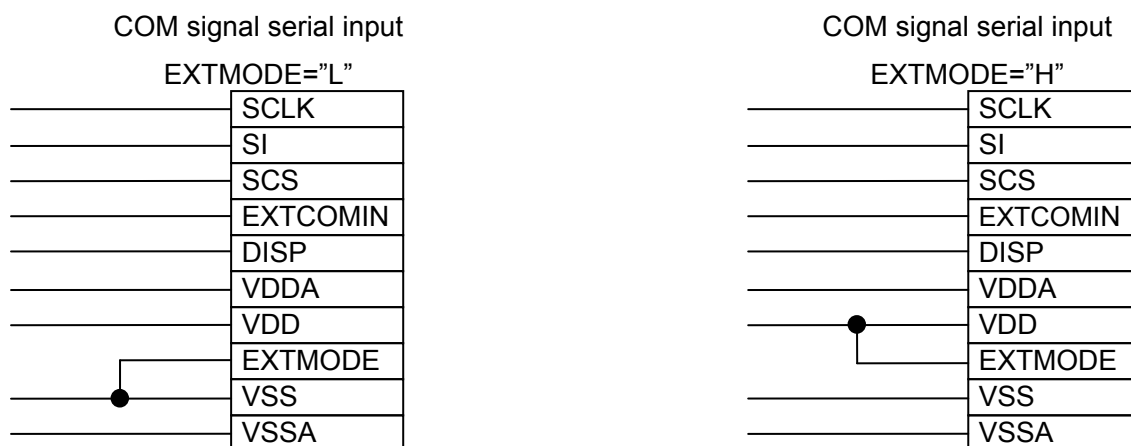

Figure 1

4-3. External circuit example

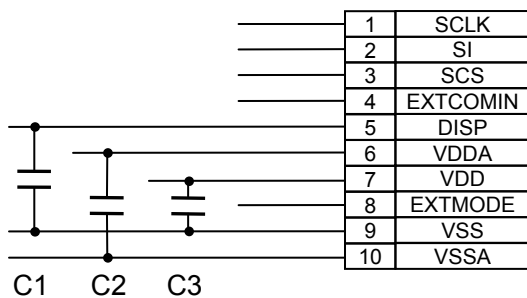

Figure 2

C1,C2: 0.1uF/B/10V

C3: 1uF/B/10V

## 5. Absolute maximum ratings

Table 3

Item	Symbol	Condition	Rated value	Unit	Remarks
Logic I/O power supply voltage	VDD	Ta = 25°C	-0.3 to +5.8	V	Note 5-1
Analog power supply voltage	VDDA	Ta = 25°C	-0.3 to +5.8	V	
Input voltage	VI	Ta = 25°C	-0.3 to VDD	V	Note 5-2
Temperature for storage	Tstg	-	-30 to +85	deg.	Note 5-3
Temperature for operation	Topr	-	-20 to +70	deg.	

[Note 5-1] Also applicable to EXTMODE

[Note 5-2] Applicable to SCLK, SI, SCS, DISP and EXTCOMIN

[Note 5-3] Humidity: 80%RH Max. (Ta≤40°C)

Maximum bulb temperature under 39°C (Ta>40°C) See to it that no dew will be condensed.

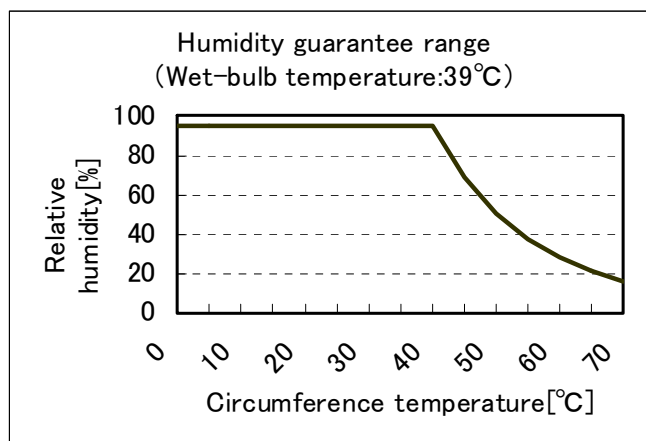

Figure 3 Humidity guarantee range

6. Electrical characteristics

6-1. TFT LCD panel driving

Ta = 25°C

**B** Table 4-1 (SCS,SCLK,SI,DISP,EXTCOMIN=3V,VDD=5V,VDDA=5V)

Power consumption	MIN	TYP	MAX	Unit	Remark
Still picture model	-	10	55	uW	no display data update
Data update mode (SCLK=1MHz)	-	45	100	uW	display data update: 1frame/sec

\*Power consumption Display pattern : Black display

\*LC inversion frequency : 1Hz (LC inversion frequency 1Hz is COM frequency 0.5Hz)

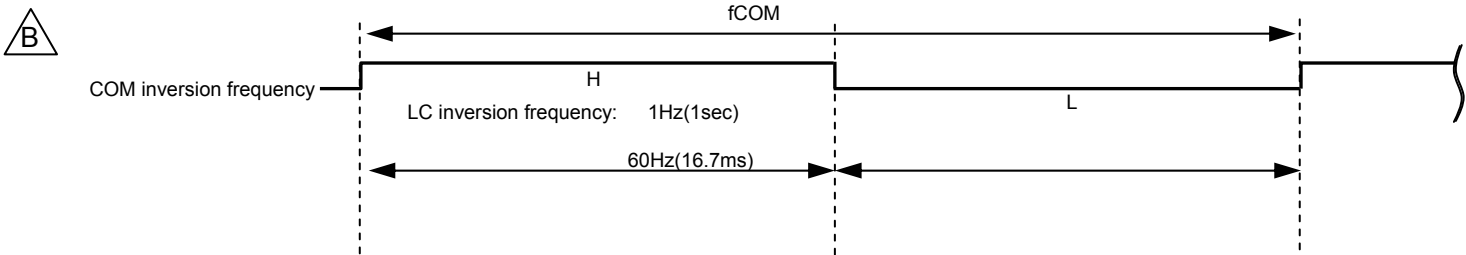

Fig A

**B** [Note 6-1] This is value in steady condition, not the value of peak power at the time of COM operation. Some margining for power supply is recommended. We recommend capacitor for VDD and VDDA. (If VDD and VDDA are on separate systems, we recommend capacitor for each.)

**B**

Table 4-2 Recommended operating Condition

VSS(GND)=0V, Ta= +25°C

Item		symbol	MIN.	TYP.	MAX.	Unit	Remark
Power supply	Analog	VDDA	+4.8	+5.0	+5.5	V	
	Logic	VDD	+4.8	+5.0	+5.5	V	[Note 6-2]
Input signal voltage	Hi	VIH	+2.70	+3.00	*VDD	V	[Note 6-3]
	Lo	VIL	VSS	VSS	VSS+0.15	V	

\*It can be operated below VDD voltage, however, operation around 3V is recommended.

**B** [Note 6-2] Applies to EXTMODE="H"

[Note 6-3] Applies to SCLK, SI, SCS, DISP, EXTCOMIN.



## 6-2. Power supply sequence

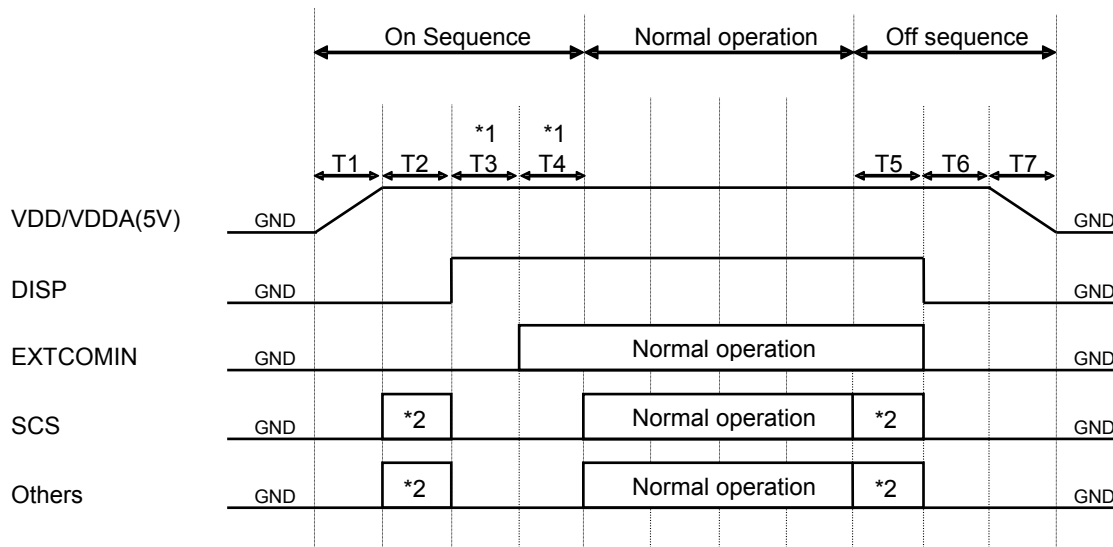

Figure 4

**[ON Sequence]**

(1) 5V rise time (depends on IC)

(2) Pixel memory initialization T2: 1V or more Initialize with M2 (all clear flag) or write all screen white

(3) Release time for initialization of TCOM latch T3: 30μs or more

Time required to release COM related latch circuit initialization which is initializing using DISP signals

(4) TCOM polarity initialization time T4: 30μs or more

Time required initializing TCOM polarity accordingly to EXTCOMIN input

**[Normal Operation]**

Duration of normal driving

**[Off Sequence]**

(5) Pixel memory initialization time T5: It is the same content as T2

(6) VA, VB and VCOM initialization time T6: 30μs or more

(7) 5V falling time (Depends on IC)

\*Refer to timing chart and AC timing characteristics for detail

\*1 T3 and T4 may be opposite (however, TCOM polarity inversion will not occur even with EXTCOMIN between DISP="L"). Also, when DISP and EXTCOMIN are simultaneously started up, allow 100μs or more before SCS starts up (It may be less than 200μs).

\*2 Setting value for pixel memory initialization

SCS=Driving accordingly to clear pixel internal memory method (use all clear flag or write all screen white)

S1=M2 (all clear flag) = "H" or write white

SCLK: Normal Driving

[Remark] Cautions when powering on

1) VDD and VDDA should rise simultaneously or VDD should rise first.

2) VDD and VDDA should fall simultaneously or VDD should fall first

## 6-3. Input signal characteristics

B Table 5

Item	Symbol	MIN	TYP	MAX	Unit	Remark
Frame frequency	fSCS	0.95	-	60	Hz	
Clock frequency	fSCLK	-	1	2	MHz	
Vertical Interval	tV	16.67	-	1000	msec	
COM Frequency	fCOM	0.5	-	30	Hz	
SCS rising time	trSCS	-	-	50	nsec	
SCS falling time	tfSCS	-	-	50	nsec	
SCS High width	twSCSH	84	-	-	μsec	Data update mode
		12	-	-	μsec	Display mode
SCS Low width	twSCLSL	1	-	-	μsec	
SCS setup time	tsSCS	3	-	-	μsec	
SCS hold time	thSCS	1	-	-	μsec	
SI rising time	trSI	-	-	50	nsec	
SI falling time	tfSI	-	-	50	nsec	
SI set up time	tsSI	120	-	-	nsec	
SI hold time	thSI	190	-	-	nsec	
SCLK rising time	trSCLK	-	-	50	nsec	
SCLK falling time	tfSCLK	-	-	50	nsec	
SCLK High width	twSCLKH	200	450	-	nsec	
SCLK Low width	twSCLKL	200	450	-	nsec	
EXTCOMIN signal frequency	fEXTCOMIN	1	-	60	Hz	Note 6-4
EXTCOMIN signal rising time	trEXTCOMIN	-	-	50	nsec	
EXTCOMIN signal falling time	tfEXTCOMIN	-	-	50	nsec	
EXTCOMIN signal High width	twEXTCOMIN	1	-	-	μsec	
DISPrising time	trDISP	-	-	50	nsec	
DISP falling time	tfDISP	-	-	50	nsec	

[Note 6-4] EXTCOMIN frequency should be made lower than frame frequency

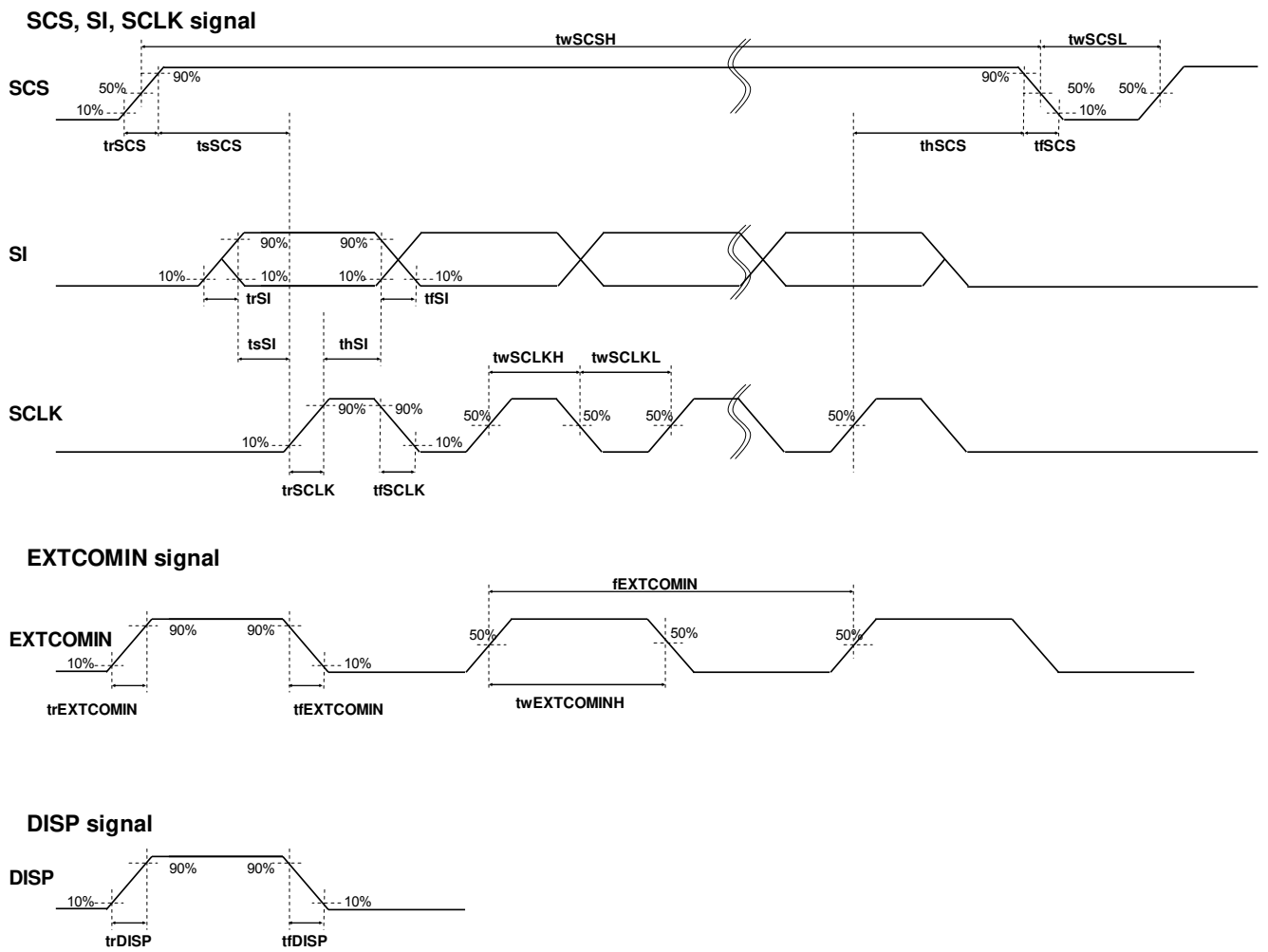

Figure 5

## 6-4. Input signal timing chart

Table 6

M0	M2	Mode
H	L	1)Data update mode (1 line)
		2)Data Update Mode (Multiple lines)
L	L	3)Display Mode
L	H	4)All Clear Mode
H	H	ignore

## 1) Data update mode (1 line)

Updates data of only one specified line (M0="H", M2="L")

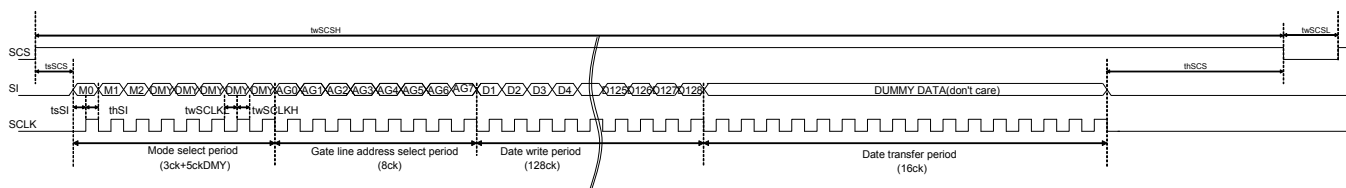

Figure 6

M0: Mode flag. Set for "H". Data update mode (Memory internal data update)

When "L", display mode (maintain memory internal data).

M1: Frame inversion flag

When "H", outputs VCOM="H", and when "L", outputs VCOM="L".

When EXTMODE="H", it can be "H" or "L".

M2: All clear flag

Refer to 6-5-4) All Clear Mode to execute clear.

DUMMY DATA: Dummy data. It can be "H" or "L" ("L" is recommended.)

\*Data write period

Data is being stored in 1<sup>st</sup> latch block of binary driver on panel.

\*Data transfer period

Data written in 1<sup>st</sup> latch is being transferred (written) to pixel internal memory circuit.

\*For gate line address setting, refer to 6-6) Input Signal and Display.

\*M1: Frame inversion flag is enabled when EXTMODE="L".

\*When SCS becomes "L", M0 and M2 are cleared.

2) Data update mode (multiple lines)

Updates arbitrary multiple lines data (M0="H", M2="L")

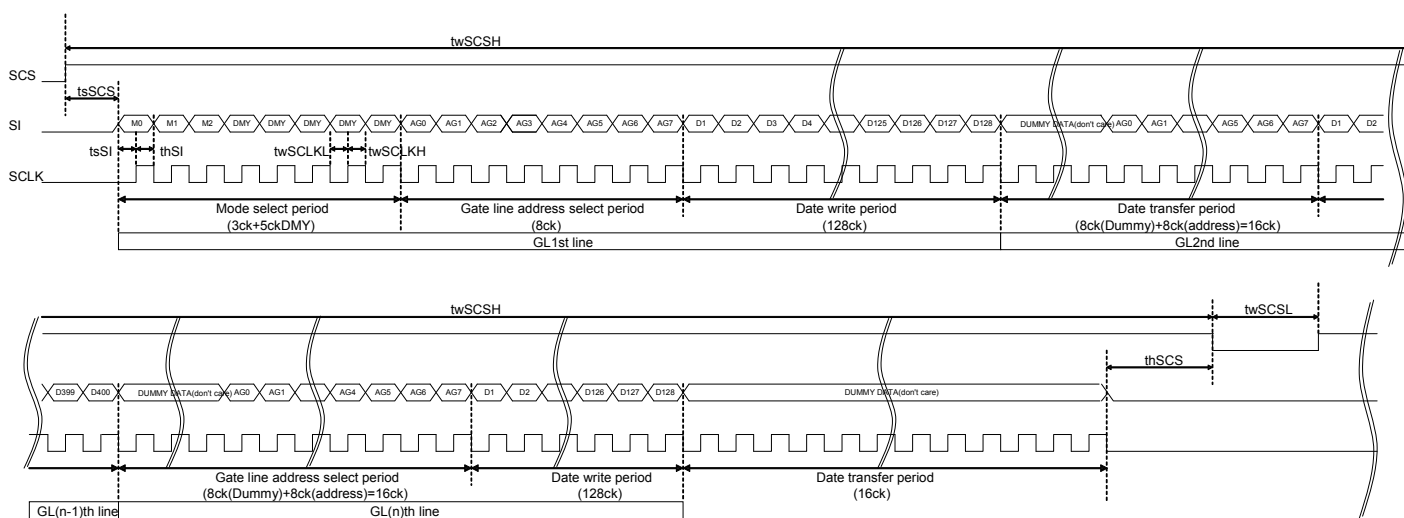

Figure 7

M0: Mode flag. Set for "H". Data update mode (Memory internal data update)

When "L", display mode (maintain memory internal data).

M1: Frame inversion flag

When "H", outputs VCOM="H", and when "L", outputs VCOM="L".

When EXTMODE="H", it can be "H" or "L".

M2: All clear flag

Refer to 6-4-4) All Clear Mode to execute clear.

DUMMY DATA: Dummy data. It can be "H" or "L" ("L" is recommended.)

\*Data write period  
Data is being stored in 1<sup>st</sup> latch block of binary driver on panel.

\*Data transfer period  
For example, during GL2nd line data transfer period, GL 2<sup>nd</sup> line address is latched and GL1st line data is transferred from 1<sup>st</sup> latch to pixel internal memory circuit at the same time.

\*For gate line address setting, refer to 6-6) Input Signal and Display.

\*Input data continuously.

\*M1: Frame inversion flag is enabled when EXTMODE="L".

\*When SCS becomes "L", M0 and M2 are cleared.

## 3) Display mode

Maintains memory internal data (maintains current display). (M0="L", M2="L")
--

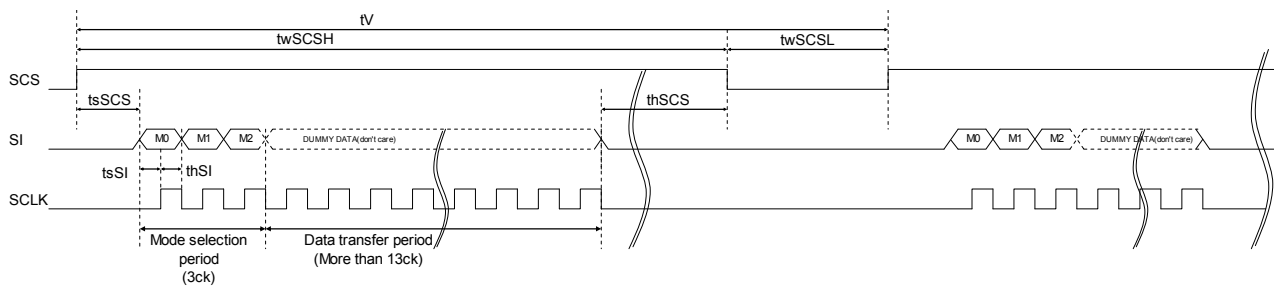

Figure 8

M0: Mode flag. Set for "H". Data update mode (Memory internal data update)

When "L", display mode (maintain memory internal data).

M1: Frame inversion flag

When "H", outputs VCOM="H", and when "L", outputs VCOM="L".

When EXTMODE="H", it can be "H" or "L".

M2: All clear flag

Refer to 6-5-4) All Clear Mode to execute clear.

DUMMY DATA: Dummy data. It can be "H" or "L" ("L" is recommended).

\*M1: Frame inversion flag is enabled when EXTMODE="L"

\*When SCS becomes "L", M0 and M2 are cleared.

## 4) All clear mode

Clears memory internal data and writes white (M0="L", M2="H")
---

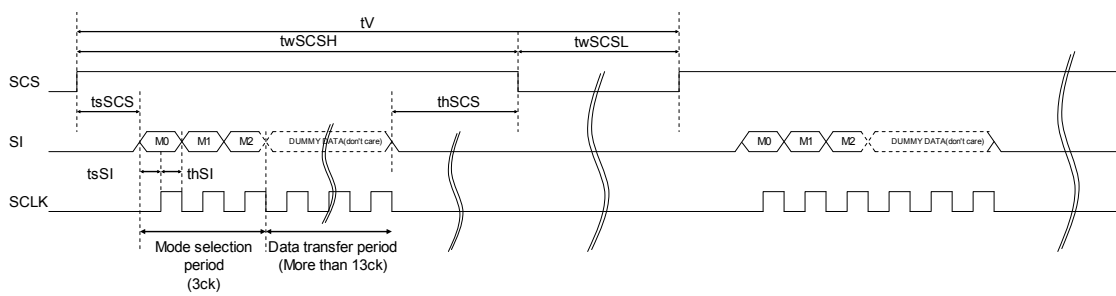

Figure 9

M0: Mode flag

Set it "L".

M1: Frame inversion flag

When "H", outputs VCOM="H", and when "L", outputs VCOM="L".

When EXTMODE="H", it can be "H" or "L".

M2: All clear flag

Set it "H"

DUMMY DATA: Dummy data. It can be "H" or "L" ("L" is recommended).

\*M1: Frame inversion flag is enabled when EXTMODE="L".

\*When SCS becomes "L", M0 and M2 are cleared.

6-5. COM inversion

There are two types of inputs, COM signal serial input (EXTMODE="L") and external COM signal input (EXTMODE="H").

1) EXTMODE="L"

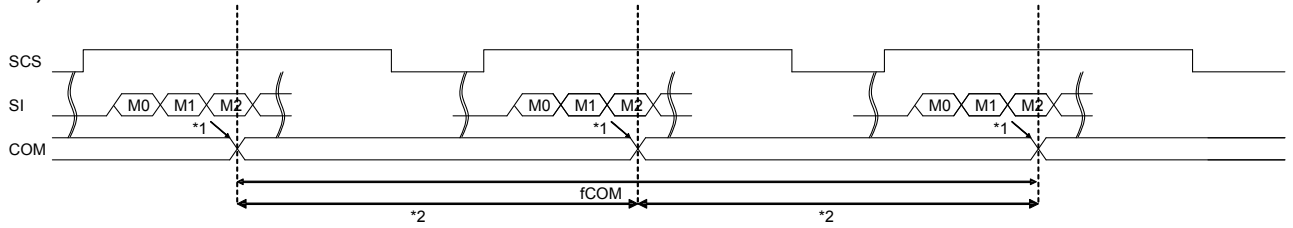

Figure 10

M1: LC polarity inversion flag: If M1 is "H" then VCOM="H" is output. If M1 is "L" then VCOM="L" is output.

\*1: LC inversion has been changed by M1 flag statement.

\*2: The periods of plus polarity and minus polarity should be same length as much as possible.

2) EXTMODE="H" (COM inversion timing has two conditions)

a) EXTCOMIN input when the SCS signal is "H"

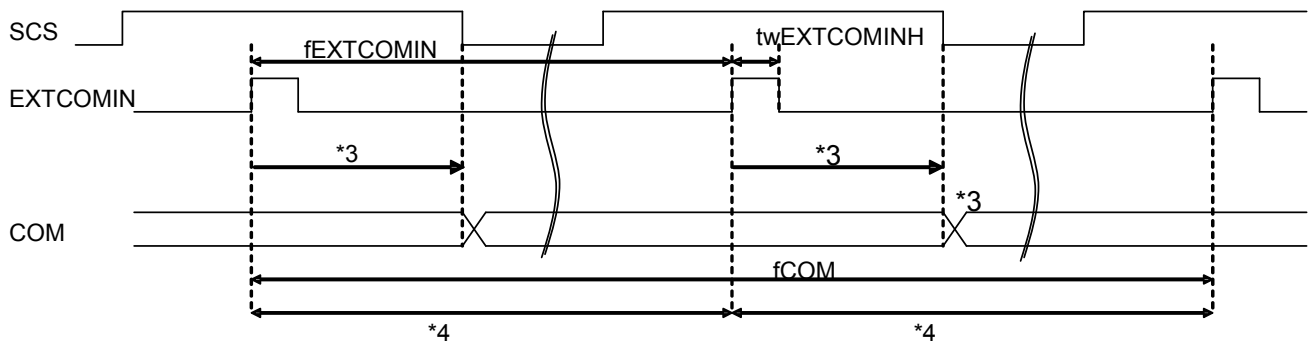

Figure 11

\*3: LC inversion polarity has been set by the rising timing of EXTCOMIN in internal circuit block as COMZ signal,

\*4: The period of EXTCOMIN should be constant.

b) EXTCOMIN input when the SCS signal is "L"

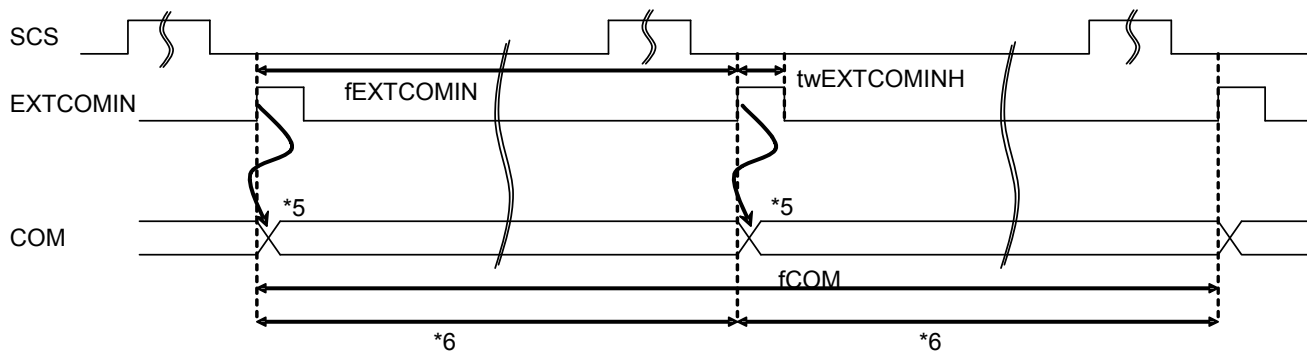

Figure 12

\*5: LC inversion polarity has been set by the rising edge of EXTCOMIN.

\*6: The period of EXTCOMIN should be constant.



6-6. Input signal and display, gate address (line) setting

Data position in display [H, V]

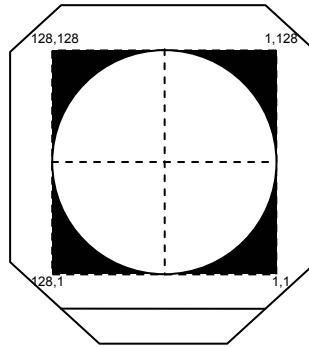

Figure 13

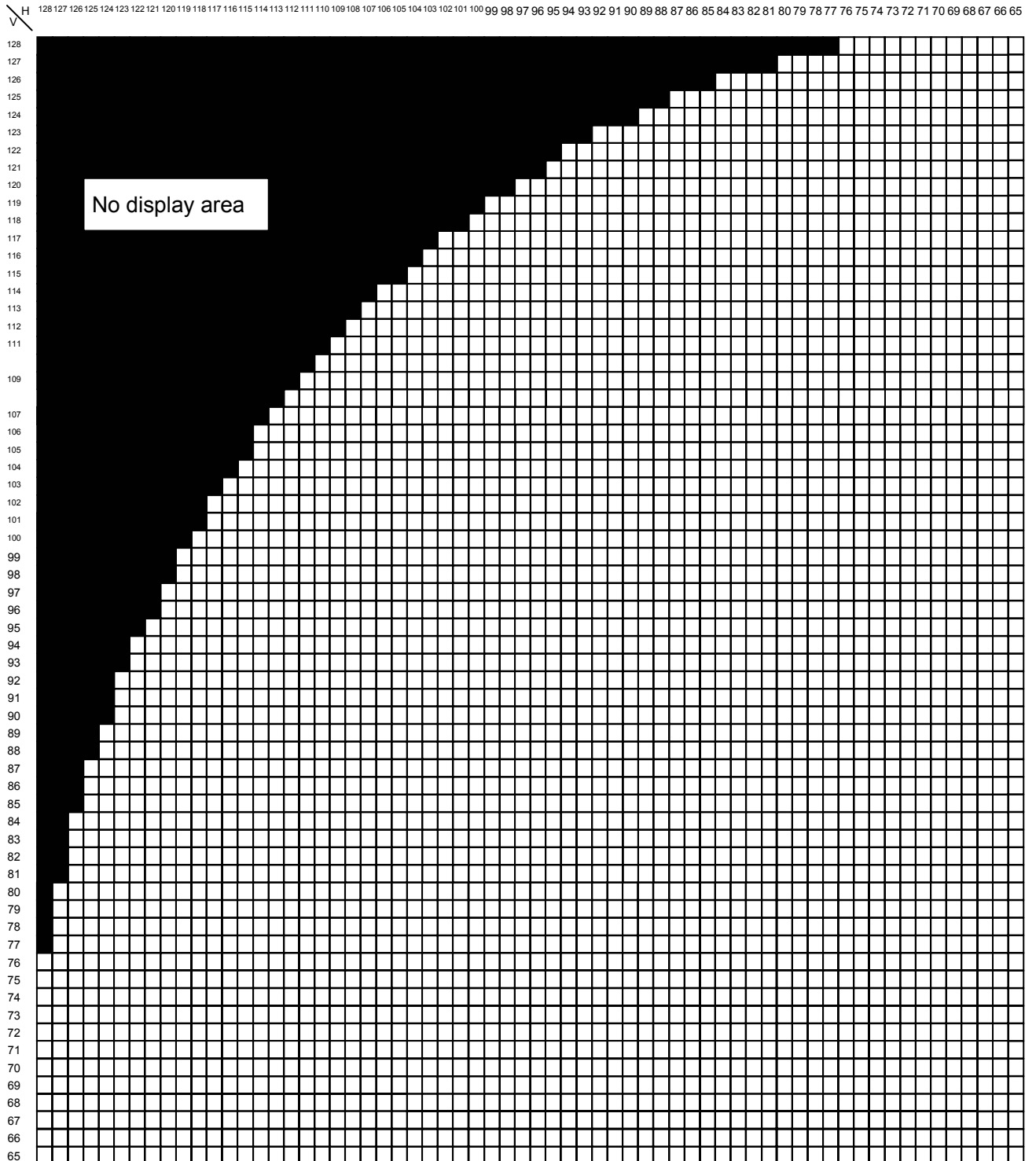

Figure 14

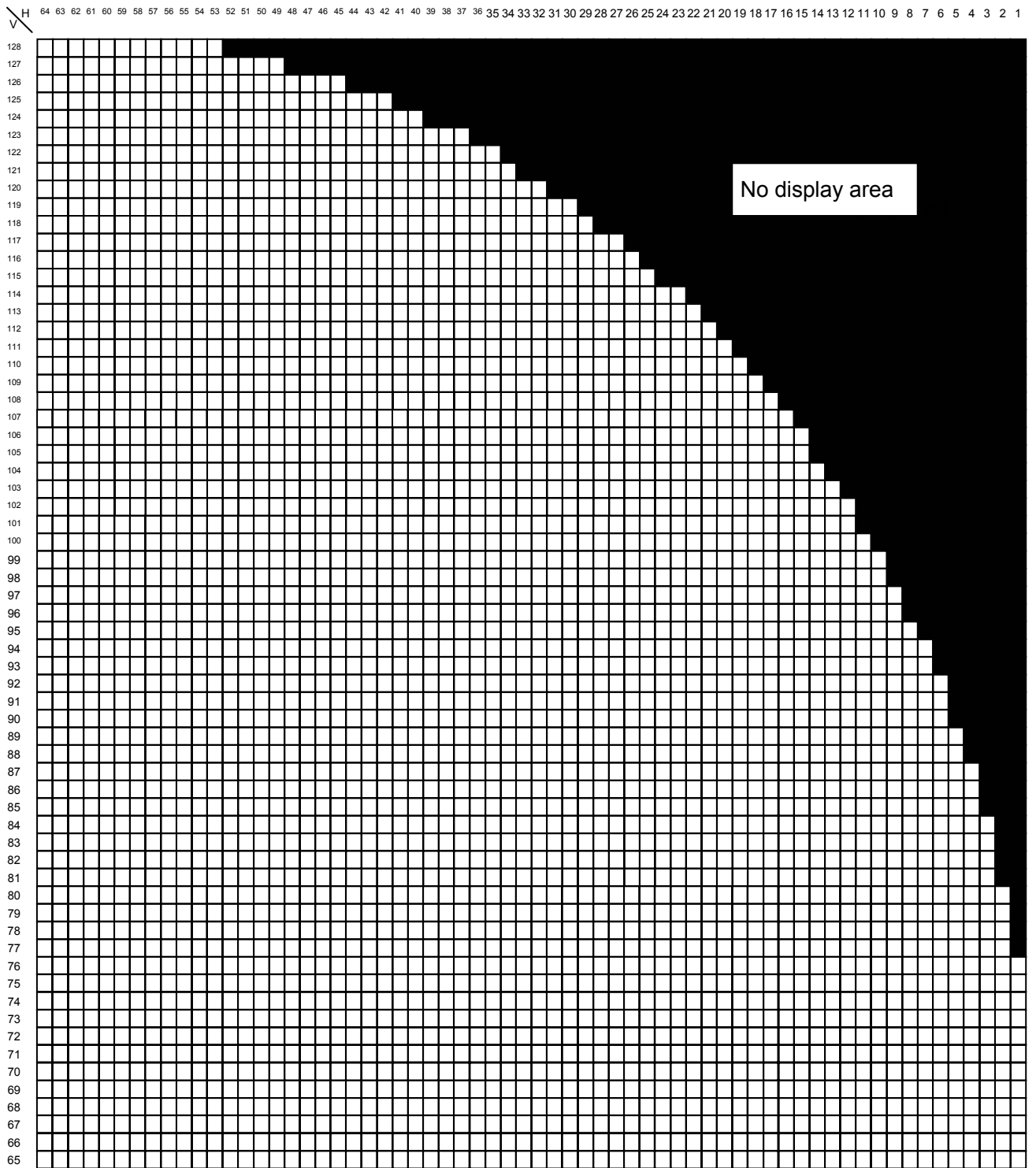

Figure 15

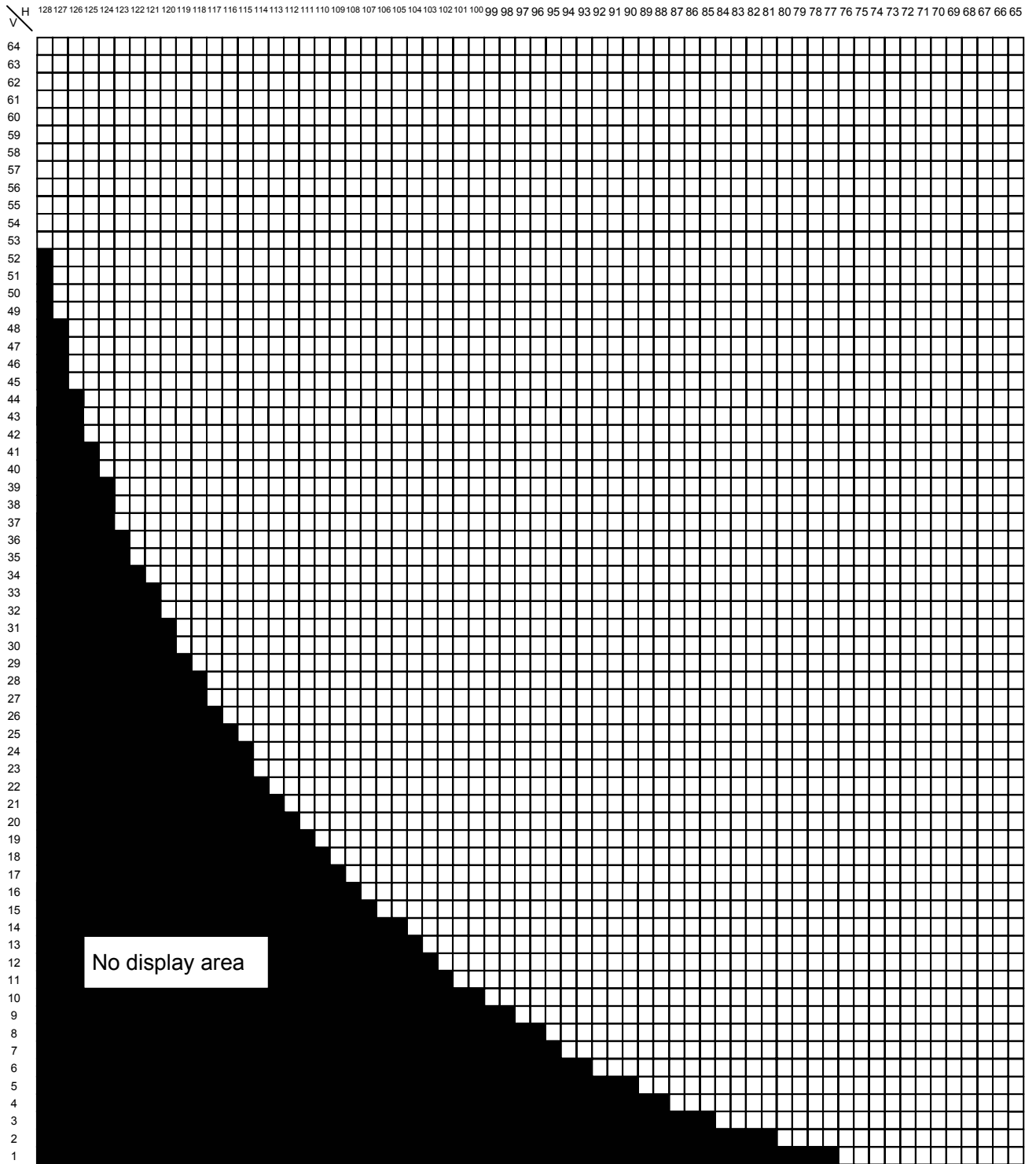

Figure 16



## 7. Optical characteristics

Table 8

Ta=25°C, VDD=VDDA=+5.0V, fSCS=1Hz

Parameter		Symbol	Condition	Min.	Typ.	Max.	Unit	Remark	
Viewing angle range	Horizontal	θ21	CR>3	40	-	-	deg.	Note 7-1 Note 7-2	
		θ22		40	-	-	deg.		
	Vertical	θ11		60	-	-	deg.		
		θ12		60	-	-	deg.		
Contrast ratio		CR	θ=0°	-	14	-		Note 7-1 Note 7-3	
Reflection ratio		R			17		%	Note 7-1	
Transmission ratio		T			-	0.25	-	%	
Response time	Rise	τr			-	10	-	msec.	Note 7-1
	Decay	τd		-	20	-	msec.	Note 7-4	
Chromaticity of White		x		-	0.30	-		Note 7-1	
		y		-	0.33	-			

[Note 7-1] This shall be measured at center of the screen.

Measurement equipment (CM-2002)

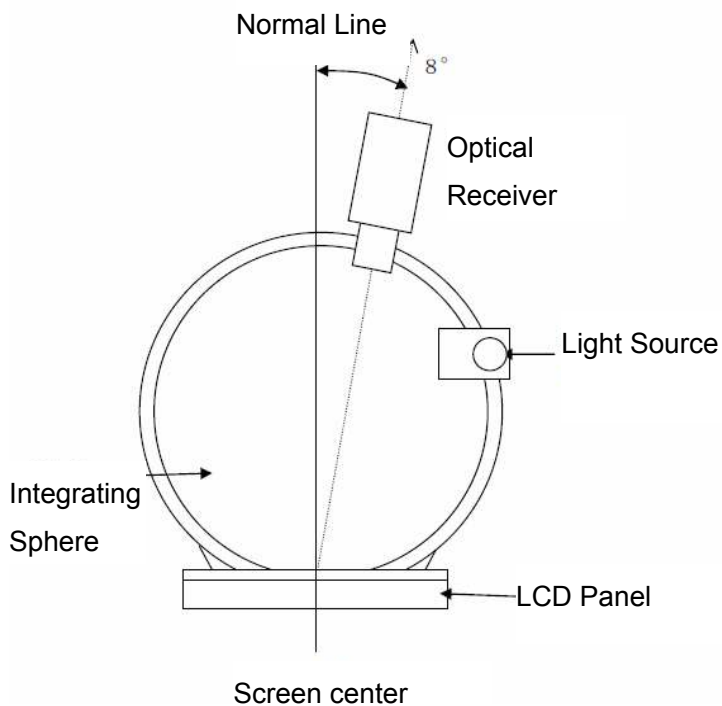

Measurement equipment (LCD-5200)

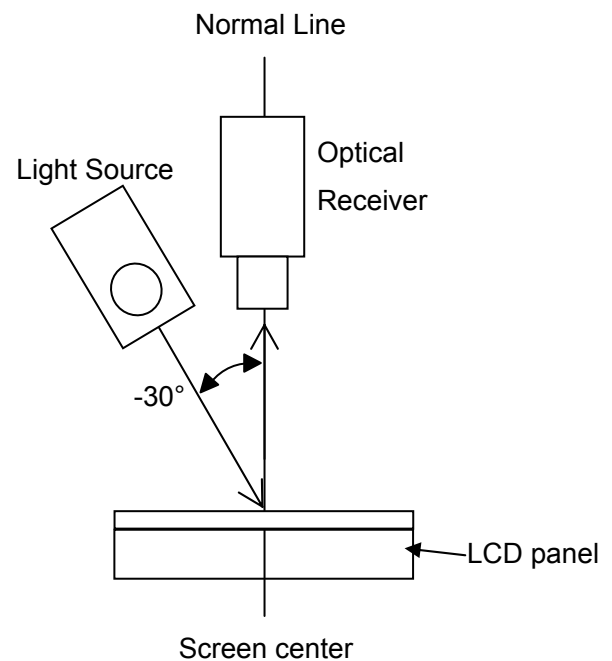

Figure 18 Measurement of contrast, reflective ratio and panel surface chromaticity

[Note 7-2] Definition of viewing angle range

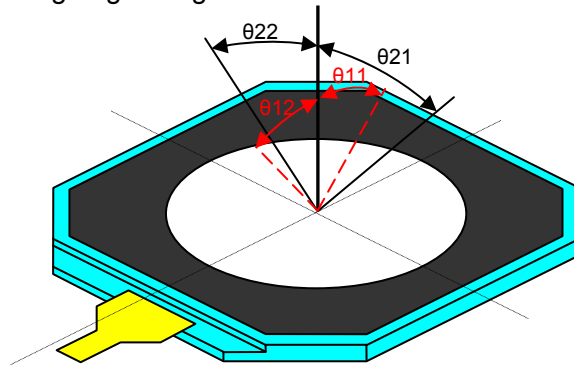

Figure 19

[Note 7-3] Definition of contrast ratio

The contrast ratio is defined as the following:

$$\text{Contrast ratio (CR)} = \frac{\text{Reflection intensity on all pixels white}}{\text{Reflection intensity on all pixels black}}$$

[Note 7-4] Definition of response time

The response time is defined as the following figure and shall be measured by switching the input signal for “black” and “white”

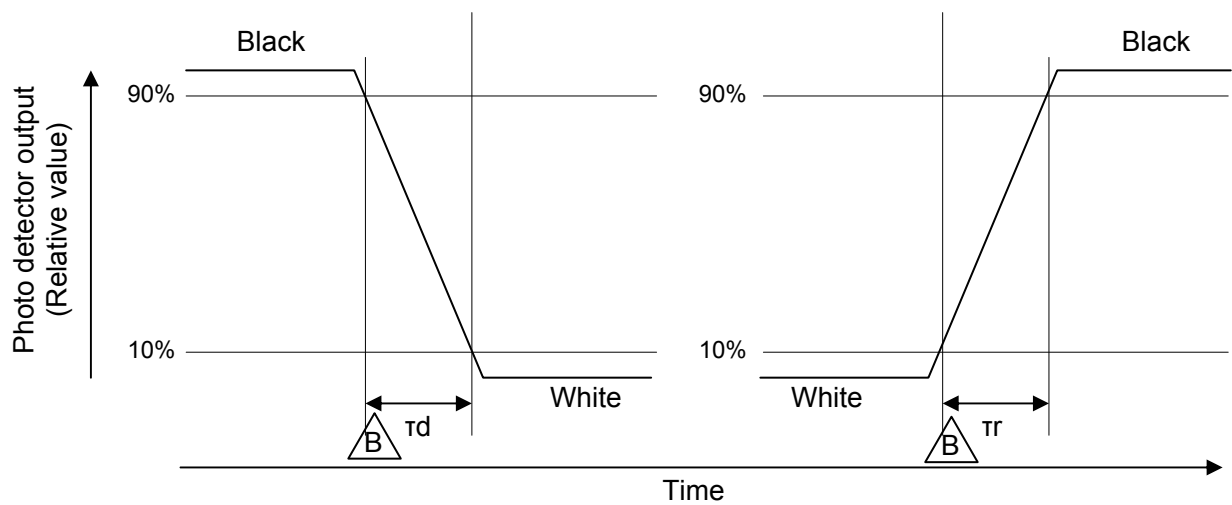

Figure 20

## 8. Handling of module

### 8-1. About handling of FPC

- 1) The bending radius of the FPC should be more than 0.7mm, and it should be bent evenly.
- 2) Do not dangle the LCD module by holding the FPC, or do not give any stress to it.

Do not bend the FPC toward the display surface of LCD module, because it will cause FPC disconnection.

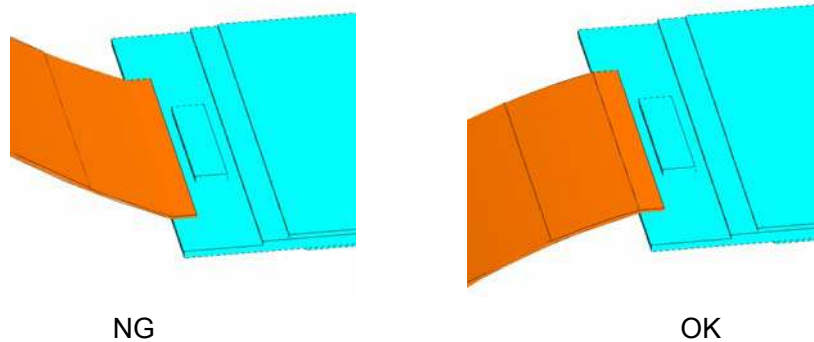

Figure 21

### 8-2. Mounting of the module

- 1) The module should be held on to the plain surface. Do not give any warping or twisting stress to the module.
- 2) Please consider that GND can ground a modular metal portion etc. so that static electricity is not charged to a module.

### 8-3. Cautions in assembly / Handling pre cautions

- 1) As the polarizer can be easily scratched, be most careful in handling it.
- 2) To avoid circuit failure, do not touch panel connective area.
- 3) Do not use chloroprene rubber as it generates chlorine gas and affects reliability in LCD panel connective area.
- 4) To avoid picture uniformity failure, do not put a seal or an adhesive material on the panel surface.
- 5) Work environments in assembly.

Working under the following environments is desirable:

- a) Implement more than 1MΩ conductive treatment (by placing a conductive mat or applying conductive paint) on the floor or tiles.
  - b) No dusts come in to the working room. Place an adhesive, anti-dust mat at the entrance of the room.
  - c) Humidity of 50 to 70% and temperature of 15 to 27°C are desirable.
  - d) All workers wear conductive shoes, conductive clothes, conductive fingerstalls and grounding belts without fail.
  - e) Use a blower for electrostatic removal. Set it in a direction slightly tilt downward so that each Module can be well subjected to its wind. Set the blower at an optimum distance between the blower and the module.
- 6) How to remove dust on the polarizer
    - a) When you use LCD module, peel off the protection laminate film attached on the display surface of LCD module.
    - b) Blow out dust by the use of an N<sup>2</sup> blower with antistatic measures taken. Use of an ionized air gun is recommendable.

- c) When the panel surface is soiled, wipe it with soft cloth.
- 7) In the case of the module's metal part (shield case) is stained, wipe it with a piece of dry, soft cloth. If rather difficult, give a breath on the metal part to clean better.
  - 8) If water drops, etc. are left on the polarizer for a long time, they are apt to cause stains or make the polarizer get discolored. Wipe it off immediately.
  - 9) As a glass substrate is used for the TFT-LCD panel, if it is dropped on the floor or hit by something hard, it may be broken or chipped off.
  - 10) Since CMOS LSI is used in this module, take care of static electricity and take the human earth into consideration when handling.
  - 11) LCD module does not have the function to limit current. In order to prevent latch up, please design your product to limit current.
  - 12) Protective film is attached to both of surface polarizer films (front polarizer and rear polarizer) on LCD panel to prevent scratches or other damages. Remove these protective films before use. In addition, do not attach the protective films which are removed from LCD module again. When the LCD panel which has the reattached protective film is needed to storage for a long time, the polarizer film might have a damage with picture quality failure.

-  13) When handling LCD module and assembling them into cabinets, be noted that storage in the environment of oxidization or deoxidization gas and the use of such materials as reagent, solvent, adhesive, resin, and etc. which generate these gasses, may cause corrosion and discoloration of LCD modules.

#### 8-4. Others

- 1) Do not store LCD modules in any place where it will be subjected to direct sunlight.  
You are requested to store under the following conditions:  
(Environmental conditions of temperature/humidity for storage)
  - a) Temperature: 0 to 40°C
  - b) Relative humidity : 90% or less
    - As average values of environments (temperature and humidity) for storing, use the following control guidelines:  
Summer season: 20 to 35°C, 85% or less   Winter season: 5 to 15°C, 85% or less
    - If stored under the conditions of 40°C and 90% RH, cumulative time of storage must be less than 240 hours.
- 2) If stored at temperatures below the rated values, the inner liquid crystal may freeze, causing cell destruction. At temperatures exceeding the rated values for storage, the liquid crystal may become isotropic liquid, making it no longer possible to come back to its original state in some cases.
- 3) If the LCD module is broken, do not drink liquid crystal or put it in the mouth.
- 4) If a water drop or dust adheres to the polarizer, it is apt to cause deterioration. Wipe it immediately.
- 5) Be sure to observe other caution items for ordinary electronic parts and components.
- 6) If local pressure is put on the display surface of LCD module for a long time, it will cause Newton ring.
- 7) Epoxy resin (amine series curing agent), silicone adhesive material (dealcoholization series and oxime series), tray forming agent (azo compound) etc, in the cabinet or the packing materials may induce abnormal display with polarizer film deterioration regardless of contact or noncontact to polarizer film.  
Be sure to confirm the component of them.



## 9. Reliability test items

Table 9

No.	Test item	Condition	
1	High temperature storage test	Ta = 85°C	240h
2	Low temperature storage test	Ta = -30°C	240h
3	High temperature & high humidity operation test	Ta = 40°C / 90%RH (No condensation)	240h
4	High temperature operation test	Ta = 70°C	240h
5	Low temperature operation test	Ta = -20°C	240h
6	Thermal shock test (non-operating)	Ta=-20°C to 70°C (30 min.) (30 min.)	10 cycles
7	Electro static discharge test	±200V/200pF(0Ω) to Terminals (Contact) (1 time for each terminals)	

[Note 9-1] Ta = Ambient temperature, Tp = Panel temperature

[Note 9-2] A still image should be displayed less than two hours, if it is necessary to display still image longer than two hour, display image data must be refreshed in order to avoid sticking image on LCD panel. In refreshing, display can be written white image by addressing white data as normal driving for this panel or DISP signal would be set as "Low".

[Check items]

In the standard condition, there shall be no practical problems that may affect the display function.

## 10. Display grade

The standard regarding the grade of monochrome LCD displaying modules should be based on the delivery inspection standard.

11. Delivery form

11-1. Carton storage conditions

**B** 1) Carton piling-up: Max11 rows

2) Environments

Temperature: 0 to 40°C

Humidity: 65% RH or less (at 40°C)

There should be no dew condensation even at a low temperature and high humidity.

**B** 3) Packing form: As shown in figure 22.

\*Cartons are weak against damp, and they are apt to be smashed easily due to the compressive pressure applied when piled up. The above environmental conditions of temperature and humidity are set in consideration of reasonable pile-up for storage.

**B** 4) Period : about 3 months

11-2. Packing composition

Table 10

Name	quantity	Note
Carton size	1	578mm × 382mm × 153mm
Tray (The number of Module)	10	Material: Electrification prevention polypropylene 100 modules / tray; 1000 modules / carton
Electrification prevention bag	1	Material: Electrification prevention polyethylene

Carton weight (1000 modules): Approx. 7.5 kg

11-3. Lot no. marking

**B** The lot No. will be indicated on individual ink jet printing. The location is as shown

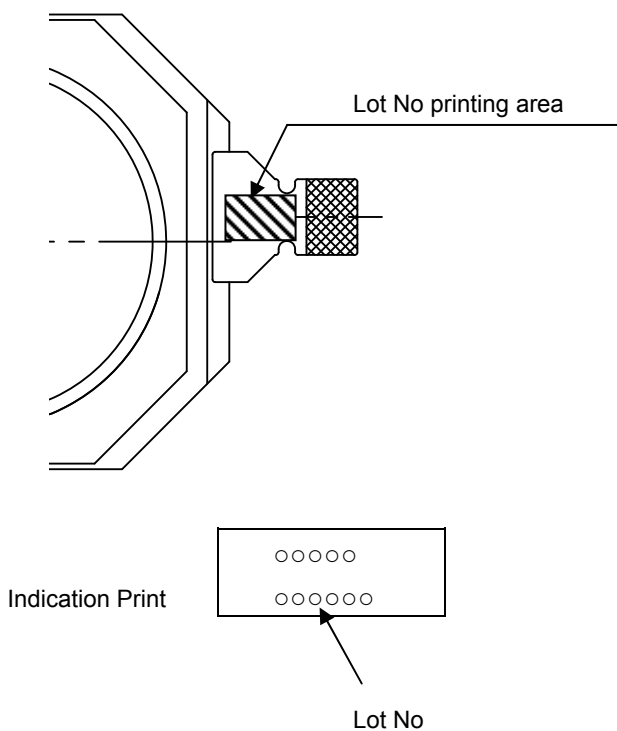

## 11-4. Packaging

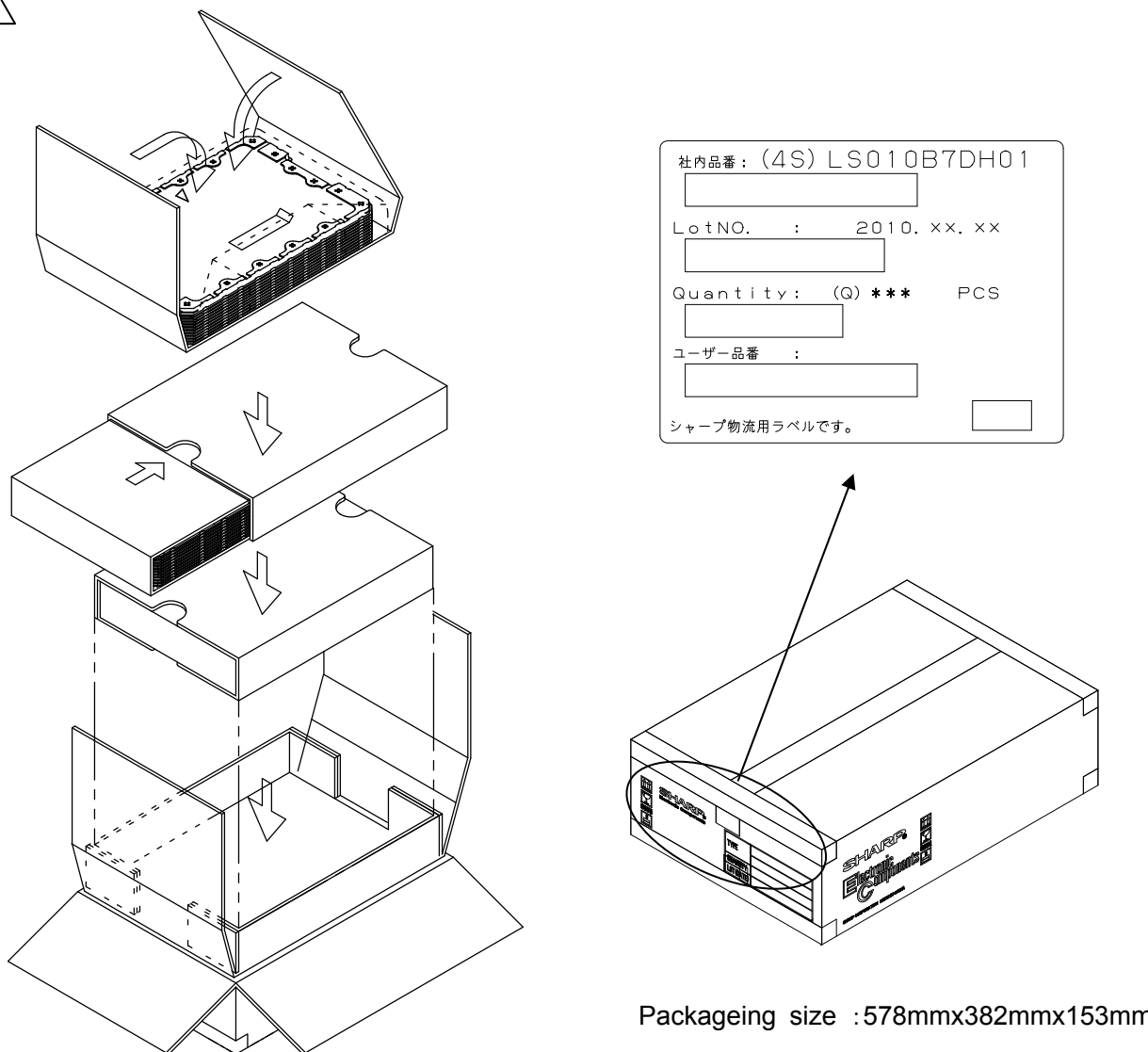

Figure 22 Packing form

## 11-5. Others

- 1) Disassembling the module can cause permanent damage and you should be strictly avoided.
- 2) Please be careful that you don't keep the screen displayed fixed pattern image for a long time, since retention may occur.
- 3) If you pressed down a liquid crystal display screen with your finger and so on, the alignment disorder of liquid crystal will occur. And then it will become display fault.  
Therefore, be careful not to touch the screen directly, and to consider not stressing to it.
- 4) If any problem arises regarding the items mentioned in this specification sheet or otherwise, it should be discussed and settled mutually in a good faith for remedy and/or improvement.

12. Outline dimensions

LCP-2110042B-26



CONFIDENTIAL

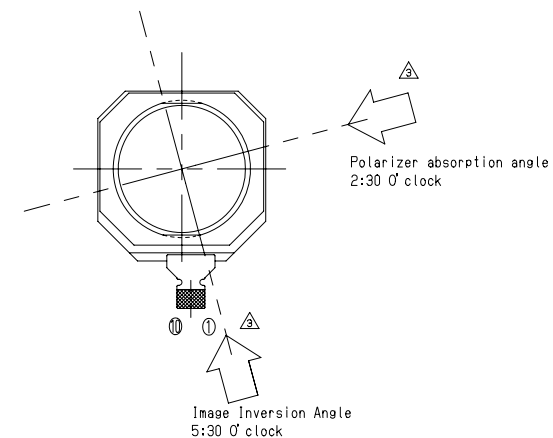
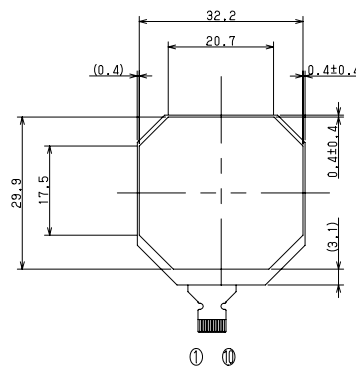
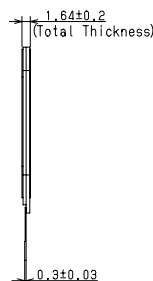
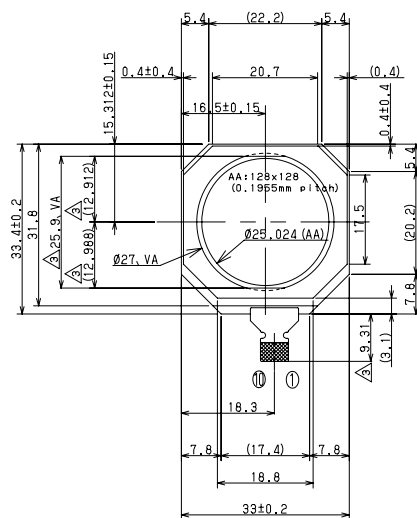

Any foreign materials, scratches, bubbles and contamination outside the Active area are to be treated as "NO-Count" at our inspections. Guarantee of appearance=LCD Viewing Area. General tolerance is ±0.3. LCD-FPC bend larger than 0.6 in radius. Please design carefully to hide the polarizer edge which are outside of the guaranteed area. Light may be leaked from the gap at outside of viewing area, please pay attentions to such leakage during the set design.

△						ORIGINAL MODEL	LS010B7DH01	
△						ACTIVE AREA SIZE	0.99" (25.024mm) 128X128dot	
△	10/11/16	FPC length was changed VA region was defined. Image Inversion Angle was added Polarizer absorption angle was added			Hibi tani	DATE	9 Nov 2010	
△	10/11/09	FPC alignment hole was changed.			Wakai Mizu Puchi	SCALE	1/1	
△	10/09/29	FPC length was changed				NAME	0.99inch Module Outline Dimensions	
Date		REVISION			担当	Unit	m m	
DESIGNER	DSN CK	DSN CK	DSN CK	ENG APPD	SHARP CORPORATION		USER	Garmin
Mizu uchi					ENGINEERING DEPT. LIQUID CRYSTAL DISPLAY DIVISION II LIQUID CRYSTAL DISPLAY GROUP		DRAWING NO	LDM-05443J
						A3		

# LCD Specification

## LCD Group



### NORTH AMERICA

Sharp Microelectronics of the Americas  
5700 NW Pacific Rim Blvd.  
Camas, WA 98607, U.S.A.  
Phone: (1) 360-834-8700  
Fax: (1) 360-834-8903  
www.sharpsma.com

### TAIWAN

Sharp Electronic Components  
(Taiwan) Corporation  
8F-A, No. 16, Sec. 4, Nanking E. Rd.  
Taipei, Taiwan, Republic of China  
Phone: (886) 2-2577-7341  
Fax: (886) 2-2577-7326/2-2577-7328

### CHINA

Sharp Microelectronics of China  
(Shanghai) Co., Ltd.  
28 Xin Jin Qiao Road King Tower 16F  
Pudong Shanghai, 201206 P.R. China  
Phone: (86) 21-5854-7710/21-5834-6056  
Fax: (86) 21-5854-4340/21-5834-6057  
Head Office:  
No. 360, Bashen Road,  
Xin Development Bldg. 22  
Waigaoqiao Free Trade Zone Shanghai  
200131 P.R. China  
Email: smc@china.global.sharp.co.jp

### EUROPE

Sharp Microelectronics Europe  
Division of Sharp Electronics (Europe) GmbH  
Sonninstrasse 3  
20097 Hamburg, Germany  
Phone: 49 (0)180 507 35 07  
Fax: (49) 40-2376-2232  
www.sharpsme.com

### SINGAPORE

Sharp Electronics (Singapore) PTE., Ltd.  
438A, Alexandra Road, #05-01/02  
Alexandra Technopark,  
Singapore 119967  
Phone: (65) 271-3566  
Fax: (65) 271-3855

### KOREA

Sharp Electronic Components  
(Korea) Corporation  
RM 501 Geosung B/D, 541  
Dohwa-dong, Mapo-ku  
Seoul 121-701, Korea  
Phone: (82) 2-711-5813 ~ 8  
Fax: (82) 2-711-5819

### JAPAN

Sharp Corporation  
Electronic Components & Devices  
22-22 Nagaiké-cho, Abeno-Ku  
Osaka 545-8522, Japan  
Phone: (81) 6-6621-1221  
Fax: (81) 6117-725300/6117-725301  
www.sharp-world.com

### HONG KONG

Sharp-Roxy (Hong Kong) Ltd.  
Level 26, Tower 1, Kowloon Commerce Centre,  
No. 51, Kwai Cheong Road, Kwai Chung,  
New Territories, Hong Kong  
Phone: (852) 28229311  
Fax: (852) 28660779  
www.sharp.com.hk  
Shenzhen Representative Office:  
Room 602-603, 6/F,  
International Chamber of Commerce Tower, 168  
Fuhua Rd. 3, CBD,  
Futian District, Shenzhen 518048,  
Guangdong, P.R. China  
Phone: (86) 755-88313505  
Fax: (86) 755-88313515

SPECIFICATIONS ARE SUBJECT TO CHANGE WITHOUT NOTICE.

Suggested applications (if any) are for standard use; See Important Restrictions for limitations on special applications. See Limited Warranty for SHARP's product warranty. The Limited Warranty is in lieu, and exclusive of, all other warranties, express or implied.

ALL EXPRESS AND IMPLIED WARRANTIES, INCLUDING THE WARRANTIES OF MERCHANTABILITY, FITNESS FOR USE AND FITNESS FOR A PARTICULAR PURPOSE, ARE SPECIFICALLY EXCLUDED. In no event will SHARP be liable, or responsible in any way, for any incidental or consequential economic or property damage.