

Transfer or duplication of this document as well as the utilisation or communication of its content are not permitted unless express consent is granted. Violations give rise to claims for damages. All rights reserved in case of patent, utility model or design patent registrations.

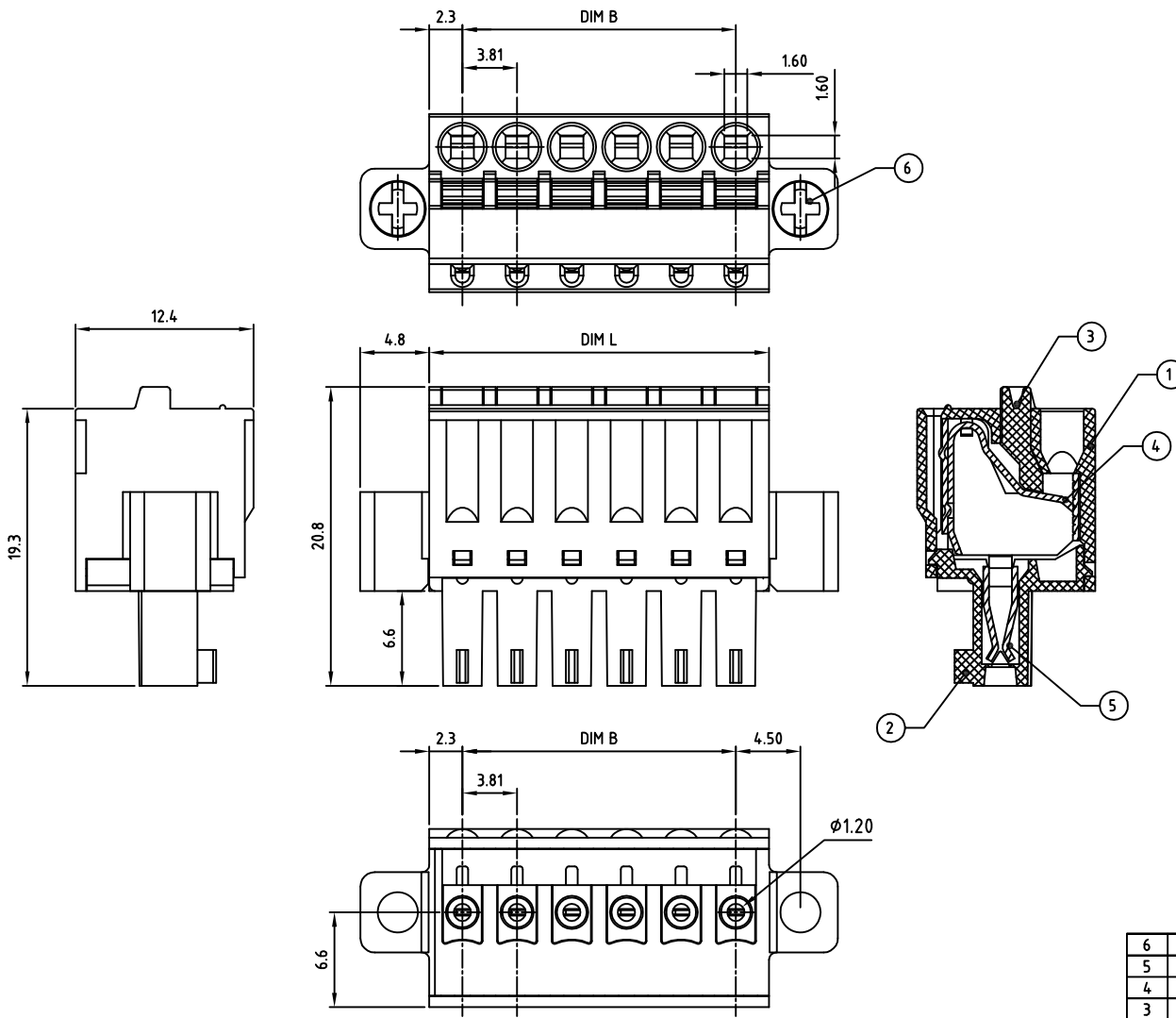

- Technical data**
- Nominal voltage: 300V/8A  
PITCH: 3.81mm
  - Connection capacity:  
AWG 28-16
  - Insulation Withstanding Voltage:  
AC 1600V/MIN
  - Insulation Resistance:  
1000M $\Omega$  or more at DC500V
  - Stripping length: 9-10mm
  - Operating temperature range: -40°C ~ 115°C
  - Undimensioned Tolerances:

Dim.L=(P-1)x3.81+4.61		
Dim.B=(P-1)x3.81		
P= number of poles		
	Dim B	Dim L
0-30mm	$\pm 0.15$	$\pm 0.20$
over 30mm-60mm	$\pm 0.20$	$\pm 0.25$
over 60mm-90mm	$\pm 0.25$	$\pm 0.30$
over 90mm	$\pm 0.30$	$\pm 0.40$

- Safety approval:
- RoHS Compliance

Part No.: **OSTHWXX3052**

No. of Poles	COLOR
02 2 Poles	0: Black
03 3 Poles	2: Red
...	3: Orange
24 24 Poles	4: Yellow
	5: Green (Standard)
	6: Blue
	8: Grey

Nonstandard colors  
Mins could apply

6	FLANGE SCREW	STEEL M 2.5	Zn PLATED	2
5	SPRING	Stainless steel		P
4	CONTACT	BRONZE (PhBz)	TIN PLATED	P
3	LEVEL	PBT UL94V-0	ORANGE	P
2	COVER	PA66 UL94V-0	ALL COLOR	1
1	BODY	PA66 UL94V-0	ALL COLOR	1
ITEM	NAME OF PART	MATERIAL	NOTES	Q"TY
DWG.	WF. Zhang	DATE 2016.07.18	UNITS: MM SHEET: 1 OF 1	Tolerance
CHK.	WF. Zhang	DATE 2016.09.14	SCALE: NONE 2.5:1 ( : ) REV.: A	X. $\pm 0.50$
APP.		DATE	TITLE: OSTHW 3.81 Series	X.X $\pm 0.30$
			With flange	X.XX $\pm 0.10$
			PART NO. OSTHWXX3052	X* $\pm 1^*$
			DWG NO. OSTHWXX3052.dwg	

SIGN	DESCRIPTION	CHK.	DATE



ON-SHORE TECHNOLOGY, INC.