

GENERAL DESCRIPTION

The SP7600 is a non-synchronous voltage mode PWM step down converter with integrated high side FET optimized to drive high power LEDs at up to 2A of continuous current. A wide 4.5V to 29V input voltage range allows for single supply operations from industry standard 5, 12 or 24V power rails.

A 1.2MHz constant operating frequency allows for small external components selection while an internal type II control loop compensation reduces the overall component count and solution footprint. A low 200mV feedback reference voltage minimizes power dissipation in the system while efficiency is maximized via a 100% duty cycle capability. Dimming and shutdown mode is provided via an enable function when required. An adjustable over current and under voltage lock out protection insures safe operations under abnormal operating conditions.

The SP7600 is pin compatible with Exar's XRP7603 and XRP7604, non synchronous buck high power led drivers respectively rated at 500mA and 1A.

The SP7600 is offered in a compact thermally enhanced lead free RoHS compliant 8-pin SO package.

APPLICATIONS

- **General Lighting and Displays**
- **Architectural and Accent Lighting**
- **Medical and Industrial Instrumentation**
- **Video Projectors**

FEATURES

- **2A Continuous Output Current Capable**
- **4.5V to 29V Single Rail Input Voltage**
- **1.2MHz Constant Switching Frequency**
- **Internal Control Loop Compensation**
- **0.2V Feedback Reference Voltage**
- **2.5% Output Voltage Accuracy**
- **Built-in Soft Start**
- **PWM & Analog Dimming Capability**
- **Adjustable Over-Current Protection**
- **Pin Compatible with 500mA rated XRP7603 & 1A rated XRP7604**
- **Thermally Enhanced Package**
- **Lead Free RoHS Compliant 8-pin SO Package**

TYPICAL APPLICATION DIAGRAM

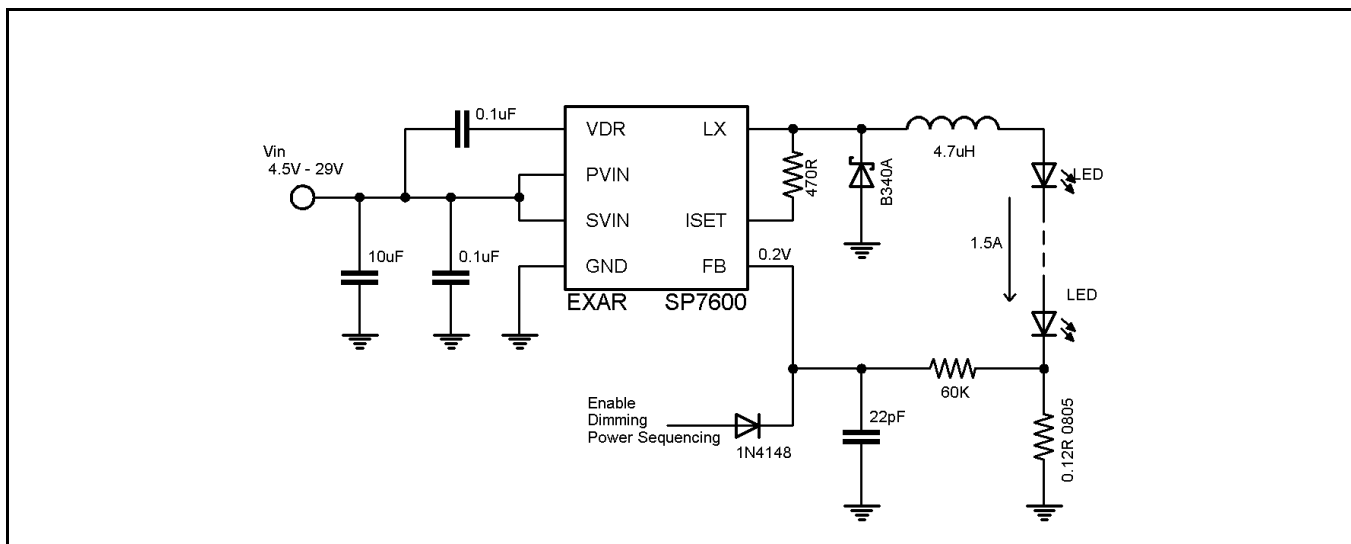

Fig. 1: SP7600 Application Diagram



ABSOLUTE MAXIMUM RATINGS

These are stress ratings only and functional operation of the device at these ratings or any other above those indicated in the operation sections of the specifications below is not implied. Exposure to absolute maximum rating conditions for extended periods of time may affect reliability.

Input Voltage -0.3V to 30V
 Lx -2V to 30V
 FB -0.3V to $V_{IN}+0.3V$
 Storage Temperature -65°C to 150°C
 Power Dissipation (Note 1) Internally Limited
 Lead Temperature (Soldering, 10 sec) 300°C
 ESD Rating (Lx, ISET) 1KV - HBM
 ESD Rating (All other pins) 2KV - HBM

OPERATING RATINGS

Input Voltage Range V_{IN} 4.5V to 29V
 Junction Temperature Range -40°C to 125°C
 Thermal Resistance θ_{JA} 59°C/W

ELECTRICAL SPECIFICATIONS

Specifications with standard type are for an Operating Junction Temperature of $T_j = 25^\circ C$ only; limits applying over the full Operating Junction Temperature range are denoted by a "•". Minimum and Maximum limits are guaranteed through test, design, or statistical correlation. Typical values represent the most likely parametric norm at $T_j = 25^\circ C$, and are provided for reference purposes only. Unless otherwise indicated, $V_{IN} = 4.5V$ to 29V, $C_{IN} = 1\mu F$, $T_j = -40^\circ C$ to 125°C.

Parameter	Min.	Typ.	Max.	Units	Conditions
UVLO Turn-On Threshold	4.0	4.2	4.5	V	$0^\circ C \leq T_j \leq 125^\circ C$
UVLO Turn-Off Threshold	3.8	4.0	4.3	V	$0^\circ C \leq T_j \leq 125^\circ C$
UVLO Hysteresis		0.2		V	
Operating Input Voltage Range	4.5		29	V	$0^\circ C \leq T_j \leq 125^\circ C$
Operating Input Voltage Range	7		29	V	•
Operating VCC Current		2	3	mA	$V_{FB}=0.1V$, not switching
Standby VCC Current		0.6	1	mA	$V_{FB}=1.2V$, not switching
Reference Voltage		200		mV	
Reference Voltage	186	200	214	mV	•
Switching Frequency	960	1200	1440	kHz	
Minimum On-Pulse Duration		40	100	ns	•
Minimum Duty Cycle			0	%	
Maximum Duty Cycle	100			%	
VDR Voltage	4.5		5.5	V	• Measure $V_{IN}-V_{DR}$ $V_{IN} > 7V$
Over-Current Threshold	300	350	400	mV	Measure $V_{IN}-Lx$
ISET Pin Input Current	25	33	40	μA	• $V_{IN}=V_{Lx}$
OFF Interval During Hiccup		100		ms	
SHDN Threshold	0.8	1.0	1.2	V	• Apply voltage to FB
SHDN Threshold Hysteresis		100		mV	
Switch On Resistance		95		$m\Omega$	
Switch Leakage		3	5	μA	

Note 1: All parameters tested at $T_A=25^\circ C$. Specifications over temperature are guaranteed by design.

BLOCK DIAGRAM

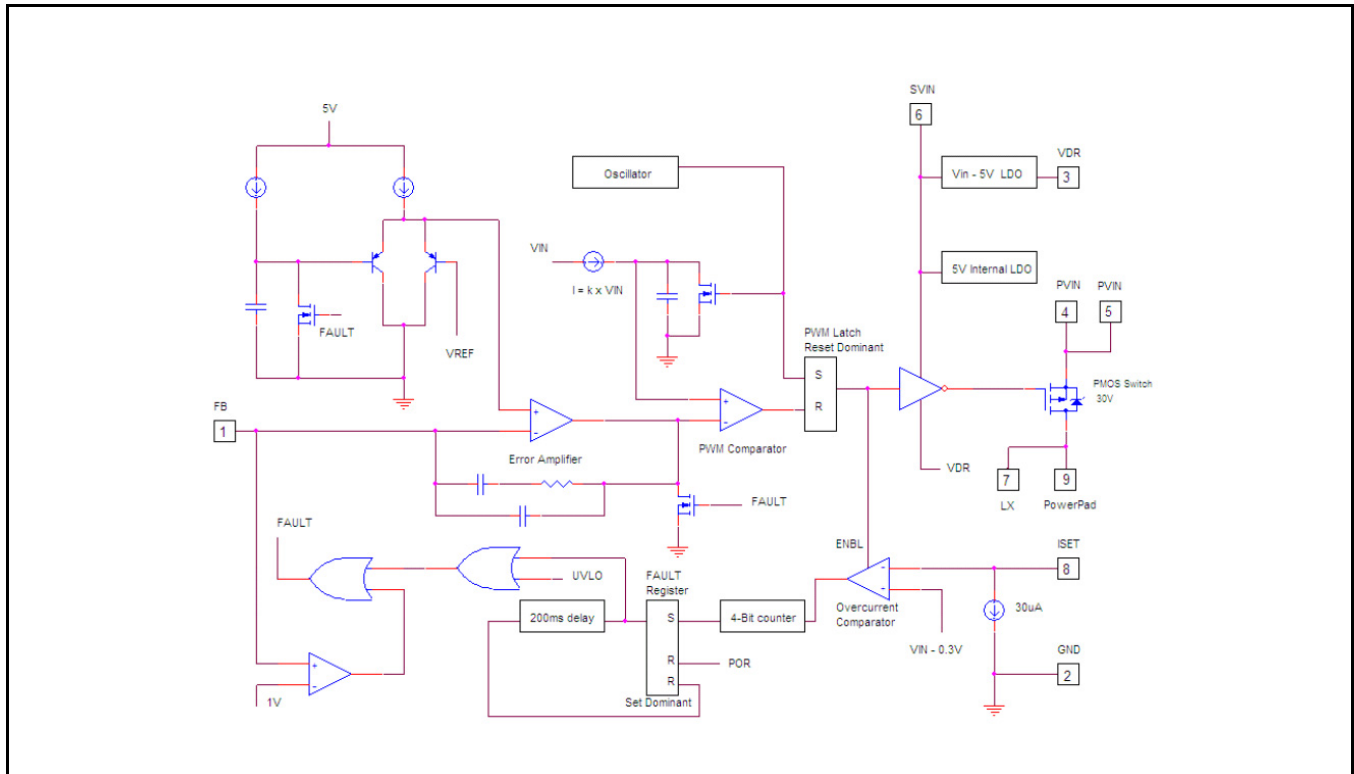

Fig. 2: SP7600 Block Diagram

PIN ASSIGNMENT

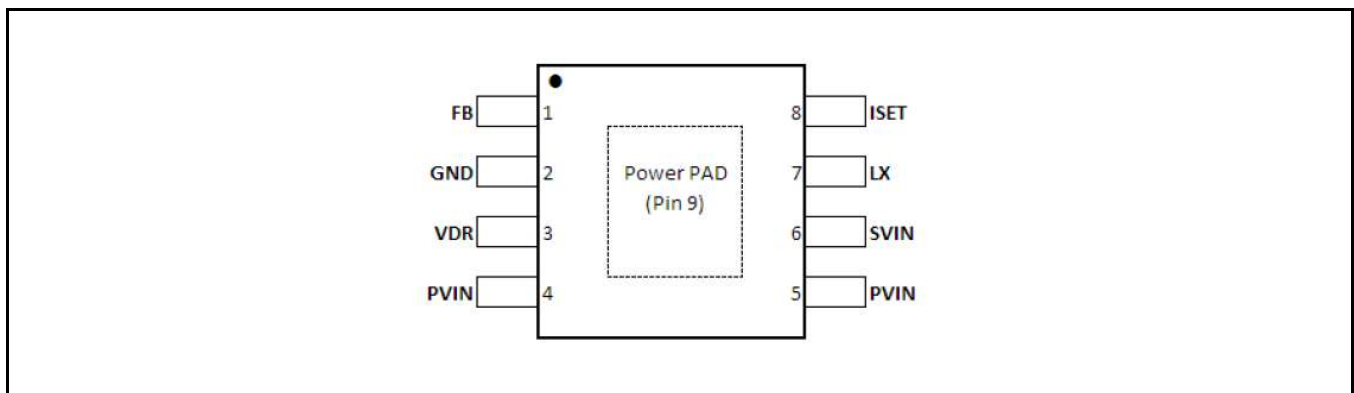

Fig. 3: SP7600 Pin Assignment



PIN DESCRIPTION

Name	Pin Number	Description
FB	1	Regulator feedback input. A current setting resistor is connected to LED's cathode and FB on one side and to ground on the other side. This pin can be also used for dimming control. By connecting a diode between this pin and a >2V signal the LED can be pulsed at up to 1kHz
GND	2	Ground pin
VDR	3	Power supply for the internal driver. This voltage is internally regulated to about 5V below VIN. Place a 0.1uF decoupling capacitor between VDR and Vin as close as possible to the IC.
PVIN	4,5	Connection to the FET source
SVIN	6	Input power supply for the regulator. Place input decoupling capacitor as close as possible to this pin. This is the Vin connection for the regulator and is not tied to the high-side FET.
LX	7	Connect to the output inductor. This is the P-Channel FET Drain
ISET	8	This pin is used as a current limit input for the internal current limit comparator. Connect to LX through an optional resistor. Internal threshold is pre-set to 350mV nominal and can be decreased by changing the external resistor based on the following formula: $VTRSHLD = 350mV - 33\mu A * R$
Power PAD	9	Can be connected to inductor LX node for a thermal PAD – see Layout suggestions section.

ORDERING INFORMATION

Part Number	Temperature Range	Marking	Package	Packing Quantity	Note 1	Note 2
SP7600EN2-L	-40°C ≤ T _j ≤ +125°C	SP7600E YYWWL X..X	HSOICN-8 Exp. PAD	Bulk	Lead Free	
SP7600EN2-L/TR	-40°C ≤ T _j ≤ +125°C	SP7600E YYWWL X..X	HSOICN-8 Exp. PAD	2.5K/Tape & Reel	Lead Free	
SP7600EB	SP7600 Evaluation Board					

"YY" = Year - "WW" = Work Week - "L" = Lead Free designator - "X" = Lot Number

TYPICAL PERFORMANCE CHARACTERISTICS

The typical performance characteristics follow and begin with an illustration of the efficiencies that can be obtained with the SP7600 driving 1 or 6 white LEDs in series for up to 2A output current. For the 6 LED applications with a 24V input, the duty cycle is high and an efficiency of 94% can be obtained. For 12V input and 1 LED at 2A output, the duty cycle is much lower, but the efficiency is still over 80%. Note: to improve line regulation a small 22pF ceramic capacitor C6 should be placed from VFB to GND to filter out any noise obtained on the sensitive FB pin.

Scope photos of output ripple are shown for the typical application circuit for 6V input at 150mVpp ripple and at 29V input with over 400mVpp output ripple, both shown with no output capacitor. For comparison, an output ripple scope photo is shown with only 70mVpp when a 1uF capacitor is used at the output. For applications sensitive to output ripple, adding this relatively small 1206 sized 1uF 50V ceramic capacitor to the output provides a very good reduction in output ripple but since the value is only 1uF the circuit will still provide good PWM output response.

Vin startup scope photos are shown for 6V, 12V and 29V input with no problems in startup as shown in the Vout, VFB and especially the inductor current signal ILX.

The last scope photos are for the output short circuit which causes a hiccup mode. The output can be shorted which causes a controlled automatic reset or hiccup mode of about 50 to 100msec period.

All data taken at $V_{IN} = 12V$, $T_A = 25^\circ C$, unless otherwise specified - Schematic and BOM from Application Information section of this datasheet.

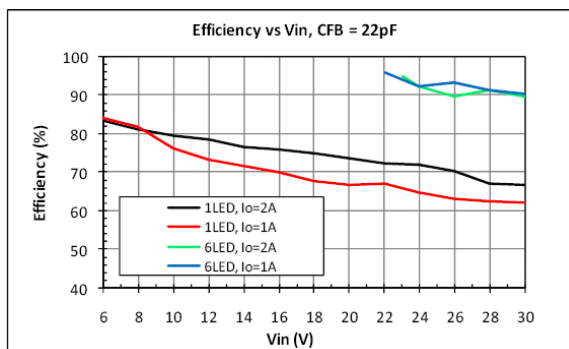

Fig. 4: Efficiency vs Input Voltage

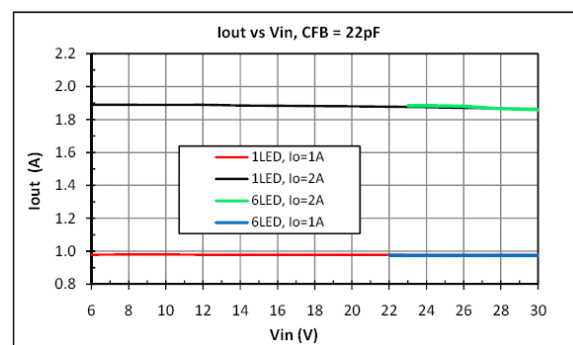

Fig. 5: Output Current vs Input Voltage

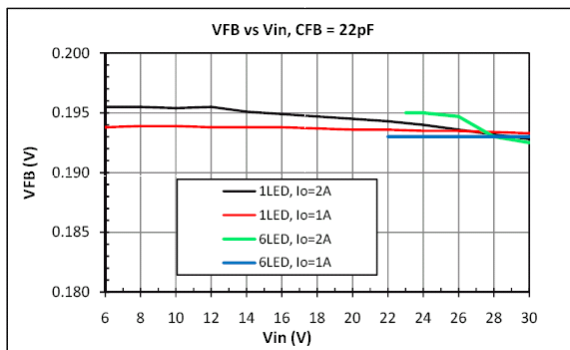

Fig. 6: Feedback Voltage vs Input Voltage

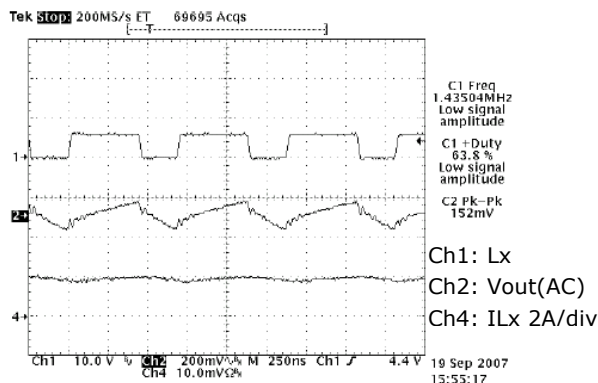

Fig. 7: No Cout, Output Ripple=150mVpp, Vin=6V
2 LEDs in parallel, Vf=3.6V @ 2A

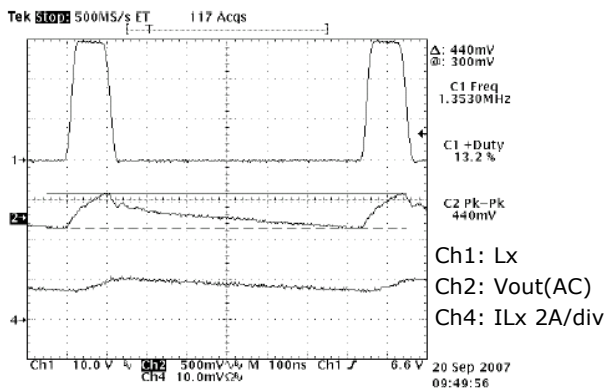

Fig. 8: No Cout, Output Ripple=440mVpp, Vin=29V
2 LEDs in parallel, Vf=3.6V @ 2A

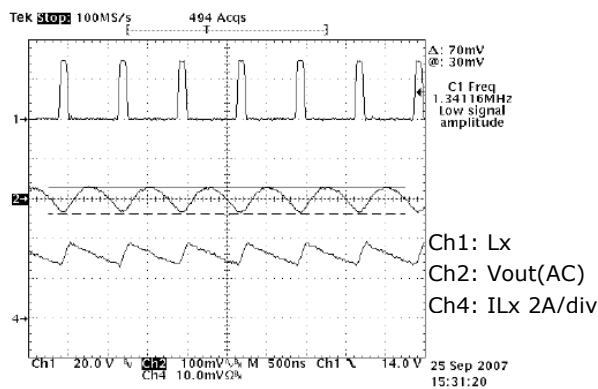

Fig. 9: Cout=1uF, Output Ripple=70mVpp, Vin=29V
2 LEDs in parallel, Vf=3.6V @ 2A

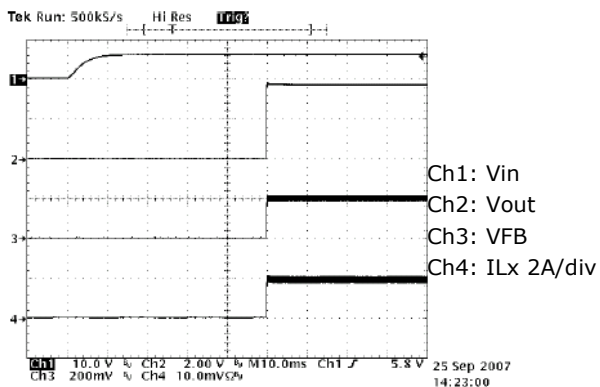

Fig. 10: 5V Vin Startup
2 LED in parallel, Vf=3.6V @ 2A

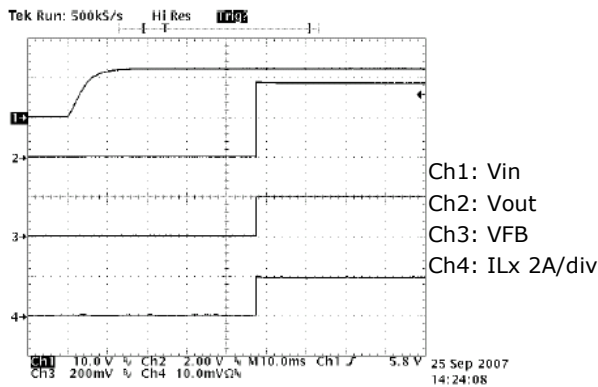

Fig. 11: 12V Vin Startup
2 LED in parallel, Vf=3.6V @ 2A

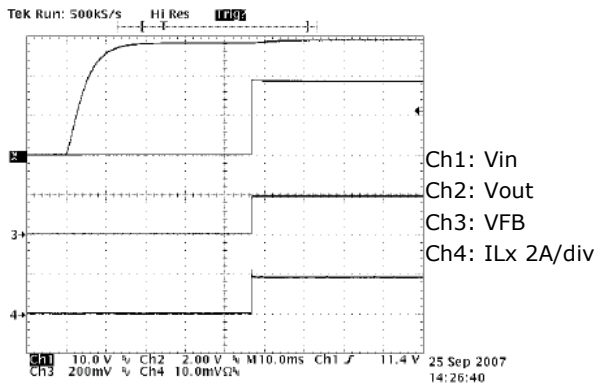

Fig. 12: 29V Vin Startup
2 LED in parallel, Vf=3.6V @ 2A

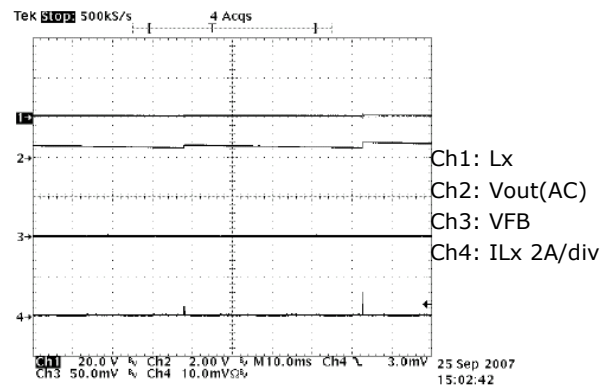

Fig. 13: Output Short Circuit
Hiccup mode with Vin=29V

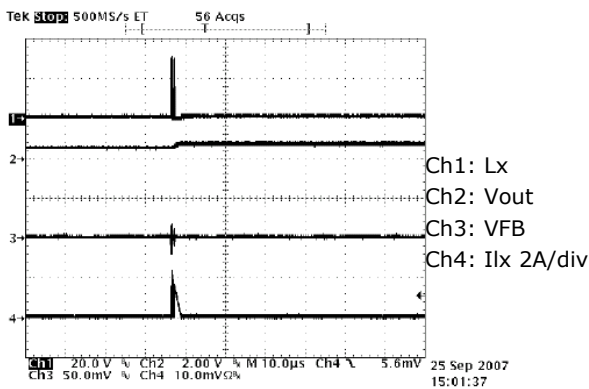

Fig. 14: OutputShort Circuit
Zoomed in on hiccup mode with Vin=29V

THEORY OF OPERATION

The SP7600 is a fixed frequency, Voltage-mode, non-synchronous buck PWM regulator optimized for driving LEDs. Constant LED current is achieved using resistor RFB as shown in the page 1 schematic. A low 0.2V reference voltage minimizes power dissipation in RFB. A tight reference voltage tolerance of ±3%, over full operating conditions, helps accurately program the LED current. High switching frequency of 1.2MHz (nominal) reduces the size of passive components. Dimming and power sequencing is achieved using a logic-level PWM signal applied to FB pin via a diode. Overcurrent protection (OCP) is based on high-side MOSFET's Rds(on) and is programmable via a resistor placed at LX node.

PROGRAMMING THE LED CURRENT

Use the following equation to program the LED current:

$$\text{Equ.1: } R_{FB} = \frac{0.2V}{I_{LED}}$$

The output voltage will adjust as needed to ensure average I_{LED} is supplied. For example if the output current has to be set at 0.35A then $R_{FB}=0.57$ Ohm. If the output LED has a corresponding V_f of 3.5V then SP7600 will step down the V_{IN} to 3.5V. If two of these LEDs are placed in series then SP7600 will step down the voltage to 7V. Superimposed on I_{LED} there is a current ripple that is equal in magnitude to inductor current ripple. Current ripple will be nominally set to 10% of I_{LED} by proper sizing of inductor. Note that throughout this datasheet I_{LED} and I_O will be used interchangeably.

DIMMING SIGNAL

A logic-level PWM signal applied through a small-signal diode to the feed-back (FB) pin can be used for dimming control of the LED. This external signal we call DIM turns the MOSFET gate drive on/off, thereby modulating the average current delivered to the LED. The DIM signal connects to the VFB pin through a 1N4148 diode and will shutdown the SP7600 when DIM = H and turn-on the SP7600 when

DIM = L. The DIM signal needs to be greater than 600mV minimum to turn-off the SP7600 and less than 200mV to fully turn-on the SP7600. It is recommended to use a signal with DIM = 1V or more for OFF and 0V for ON. The user should note that the logic is reversed relative to many other PWM controlled LED drivers. In other words a logic level high at 20% duty cycle will result in approximately an 80% duty cycle for the LED. Recommended modulation frequencies are from 100Hz to 200Hz with 10 – 90% duty cycle, 500Hz with 10 – 80% duty cycle, and 1000Hz with 10 - 70% duty cycle. Figures 15 & 16 show the output response at the maximum PWM DIM signal of 1000Hz. See figure 17 for 100Hz to 1000Hz duty cycle response for two Luxeon K2 LEDs in parallel at 2A total current.

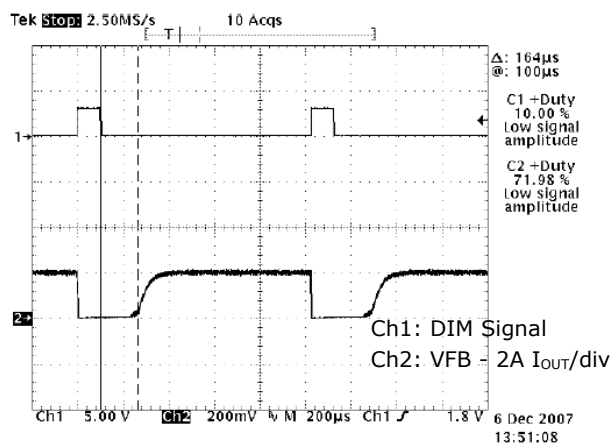

Fig. 15: 1.1KHz, 10% Duty Cycle Dimming Signal
Dimming Signal is ~70% LED Duty Cycle

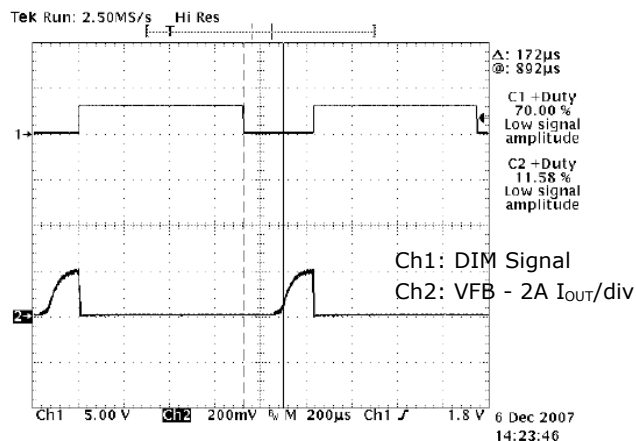

Fig. 16: 1KHz, 70% Duty Cycle
Dimming Signal is ~10% LED Duty Cycle

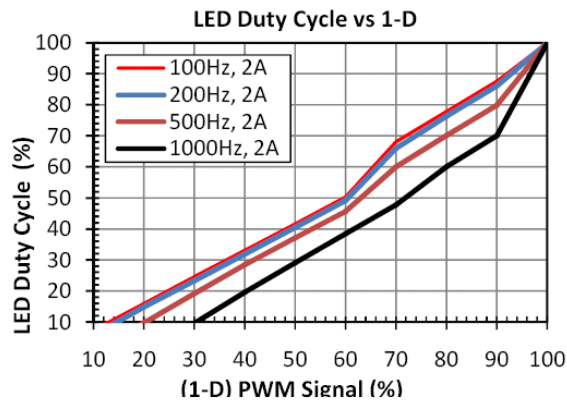

Fig. 17: LED Duty Cycle vs (1-D) DIM pin Duty Cycle
 $V_{in}=12V$, 2 Luxeon K2 in Parallel with 2A total

MODULATOR OPERATION AND POWER SEQUENCING

The SP7600 has a unique modulator design which improves the device's ability to operate at very high duty cycle. While seamless in operation as the duty cycle is increasing (input voltage falling), when the duty cycle is decreased (input voltage rising), the user will observe the switching frequency increasing in distinct fractions of the switching frequency. If the device is operating at 100% duty cycle, a unique advantage of using a p-channel pass device, and then the input voltage is increased, the frequency will start at 300kHz, then 600kHz, and then finally 1.2MHz. The frequency will tend to increase to the next higher fraction once the duty cycle reaches 75 to 65 percent. This is the normal operation of the device and should be expected. There is no impact on the LED current accuracy. If PWM dimming is being used as the input voltage is increased, one will see the frequency increasing when the duty cycle is < 90%. When power is initially applied the device will begin operating as if the input voltage is increasing and may start operation at one of the fractional operating frequencies. Many users will prefer to have the device start operating at the nominal operating frequency, thus it is recommended that V_{in} be applied after FB is set at the high state (>1.2V). The regulator is now in standby and once V_{in} has reached steady-state then FB is transitioned from a high to a low state. The regulator then starts operating at nominal frequency.

Another benefit of using power sequencing for power up is that it ensures all internal circuitry is alive and fully operational before the device is required to regulate the current through the LEDs. Since the regulator was "Off" before power was applied, it is unlikely the LED is under any type of thermal stress. EXAR does not recommend using the SP7600 in applications where dimming of the LED is achieved by PWM'ing the actual input power as is common in automotive dimming applications.

BUCK OPERATION WITHOUT OUTPUT CAPACITOR

In order to be able to apply the aforementioned dimming signal to the LED, the output filter capacitor that is normally used with a buck converter has to be removed from the circuit. Thus the LED current ripple equals the inductor current ripple. As a rule of thumb current ripple should be limited to 30% of I_{LED} . Allowing for a higher current ripple, up to 30%, while staying within LED manufacturer ripple guidelines, will reduce inductance and possibly inductor size.

OVERCURRENT PROGRAMMING

Resistor R_s can be used to program Overcurrent Protection (OCP). Use the following equation for calculating the R_s value.

$$\text{Equ.2: } R_s = \frac{0.35V - (1.5 \times 1.05 \times I_{OCP} \times R_{ds(on)})}{33\mu A}$$

Where I_{ocp} is the programmed overcurrent and is generally set 50% above nominal output current, and $R_{ds(on)} = 95\text{mohms}$.

Maximum value of R_s that can be used for programming OCP is 3k.

INDUCTOR SELECTION

Select the inductor L_1 for inductance, I_{rms} and I_{sat} . Calculate inductance from

$$\text{Equ.3: } L = \frac{V_o \times (V_{in} - V_o)}{V_{in} \times f \times \Delta I_L}$$

Where V_{in} is converter input voltage and V_o is converter output voltage. Since voltage across R_{set} is small, V_o approximately equals V_f (for



a string of series connected LEDs V_o equals total V_f)

ΔI_L is inductor current ripple (nominally set to 30% of I_o)

Inductor I_{sat} and I_{rms} must allow sufficient safeguard over output current I_o . As a rule of thumb these parameters should be 50% higher than I_o . Where high efficiency is required a low DCR inductor should be used.

INPUT CAPACITOR SELECTION

Select the input capacitor for capacitance and ripple current rating. Use the capacitances listed in the table 1 as a starting point and if needed increase C_{in} .

I_o (A)	C_{in} (µF)
<0.7	2.2
0.71 to 1.2	4.7
>1.2	2 x 4.7

Table 1: C_{in} Selection

Calculate the ripple current requirement from:

$$\text{Equ.4: } I_{rip} = I_o \times \sqrt{D \times (1 - D)}$$

Where $D = \frac{V_o}{V_{in}}$

Ceramic capacitors are recommended for input filtering due to their low Equivalent Series

Resistance (ESR), Equivalent Series inductance (ESL) and small form factor.

SCHOTTKY RECTIFIER SELECTION

Select the Schottky D1 for Voltage rating V_R and current rating I_f . Recommended schottky diode voltage rating for 12V and 24V applications is 30V and 40V respectively. Current rating can be calculated from:

$$\text{Equ.5 : } I_f \geq \sqrt{1 - \frac{V_o}{V_{in}}} \times I_o$$

Note that in applications where duty cycle is low, Schottky losses comprise a larger percentage of converter losses. In order to improve the efficiency in these applications choose a Schottky that meets the calculated current rating and has a lower V_f .

FEEDBACK RESISTOR RFB

R_2 is part of SP7600 loop compensation network. Use a 30k R_2 for V_{in} of 20V and larger. Use R_2 of 60K for V_{in} less than 20V.

CAPACITOR C5

This is the decoupling capacitor for the power supply for the internal driver. Use a 0.1µF and place as closely to VDR and SVIN pins as possible.

DESIGN EXAMPLE

Design a drive circuit for a 1.5A LED with a 12V input voltage. Nominal LED voltage is 3.6V.

Resistor RFB calculation

$$RFB = \frac{0.2V}{1.5A} = 0.13\Omega$$

A standard value of 0.12ohm 0805 is selected.

Inductor L1 calculation

$$L1 = \frac{3.6V \times (12V - 3.6V)}{12V \times 1.3MHz \times 0.45A} = 4.3\mu H$$

An inductor of 4.7uH, rated at 3A_{RMS} and 3A I_{SAT} is selected.

Input capacitor

A 10μF C_{IN} (C1) is needed (refer to table 1). From Equ.4, the ripple current rating of C_{IN} is a fraction of 1.5A. A 10uF/16V ceramic capacitor easily meets this requirement and offers low ESR and ESL.

LAYOUT CONSIDERATION

- i) Place the bypass capacitors C4 and C5 as close as possible to the 7600 IC. See figure 5 for details.
- ii) Create a pad under the IC that connects the power pad (pin 9) to the inductor. Duplicate this pad through the pcb layers if present, and on the bottom side of the PCB. Use multiple vias to connect these layers to aid in heat dissipation. Do not oversize this pad - since the LX node is subjected to very high dv/dt voltages, the stray capacitance formed between these islands and the surrounding circuitry will tend to couple switching noise
- iii) Connect the Schottky diode cathode as close as possible to the LX node and inductor input side. Connect the anode to a large diameter trace or a copper area that connects the input ground to the output ground.
- iv) The output capacitor, if used, should be placed close to the load. Use short wide

Schottky current rating I_F

$$I_F \geq \sqrt{1 - \frac{3.3V}{12V}} \times 1.5A = 1.3A$$

Voltage rating should be 30V. B340A rated at 30V/3A or equivalent can be used for its ample current rating and low forward voltage.

Rs calculation

$$R_s = \frac{0.35V - (1.5 \times 1.05 \times 2.25A \times 0.095\Omega)}{33\mu A} = 424\Omega$$

Use standard resistor value for R_s of 470Ω.

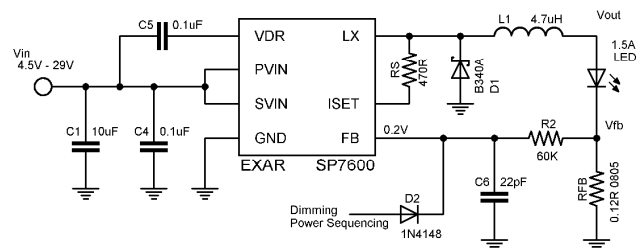

Fig. 18: Circuit for design example

copper regions to connect output capacitors to load to minimize inductance and resistances.

v) Keep other sensitive circuits and traces away from the LX node in particular and away from the power supply completely if possible.

For more detail on the SP7600 layout see the SP7600EB Evaluation Board Manual available on our web site. Each layer is shown in detail as well as a complete bill of materials.

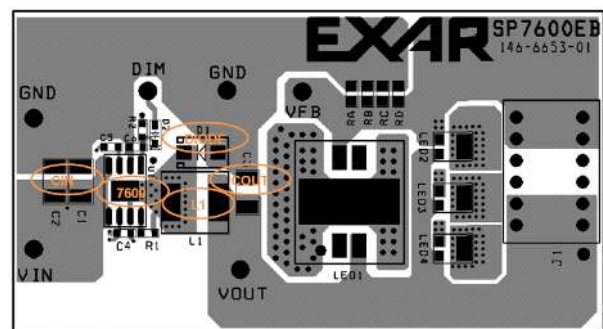
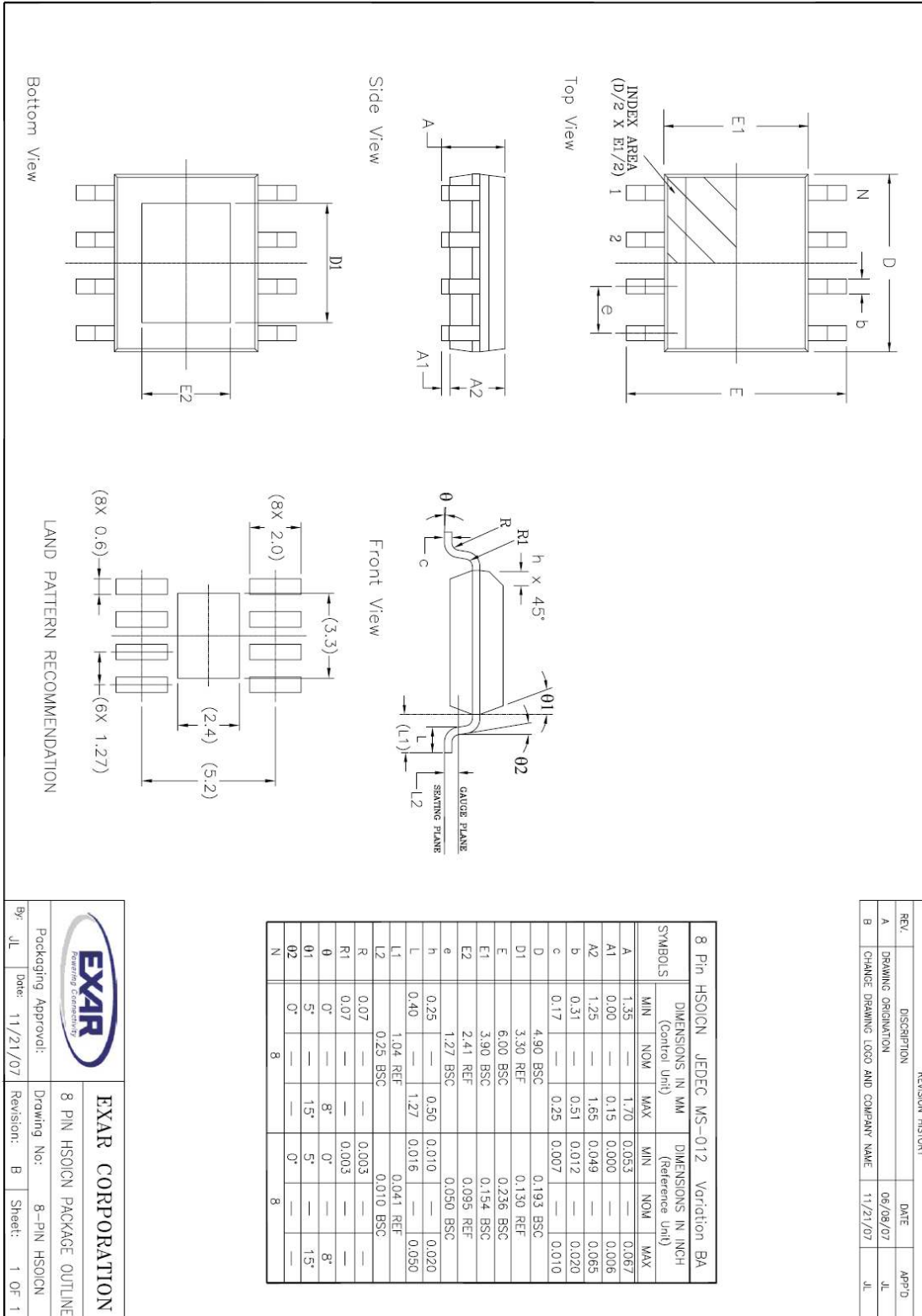

Fig. 19: SP7600 Eval Board Component Side Lay

PACKAGE SPECIFICATION

8-PIN HSOICN



REVISION HISTORY			
REV.	DESCRIPTION	DATE	APP'D.
A	DRAWING ORIGINATOR	06/09/07	JL
B	CHANGE DRAWING LOGO AND COMPANY NAME	11/21/07	JL

		EXAR CORPORATION	
Packaging Approval: JL		Drawing No: 8-PIN HSOICN	
Date: 11/21/07		Revision: B	
		Sheet: 1 OF 1	



SP7600

2A 29V Non-Sync. Buck High Power LED Driver

REVISION HISTORY

Revision	Date	Description
1.0	12/17/2007	First release of data sheet
2.0.0	03/17/2009	Reformat of Datasheet Addition of pin compatibility with Exar's XRP7603 and XRP7604

FOR FURTHER ASSISTANCE

Email: customersupport@exar.com
Exar Technical Documentation: <http://www.exar.com/TechDoc/default.aspx?>



EXAR CORPORATION

HEADQUARTERS AND SALES OFFICES

48720 Kato Road
Fremont, CA 94538 – USA
Tel.: +1 (510) 668-7000
Fax: +1 (510) 668-7030
www.exar.com

NOTICE

EXAR Corporation reserves the right to make changes to the products contained in this publication in order to improve design, performance or reliability. EXAR Corporation assumes no responsibility for the use of any circuits described herein, conveys no license under any patent or other right, and makes no representation that the circuits are free of patent infringement. Charts and schedules contained here in are only for illustration purposes and may vary depending upon a user's specific application. While the information in this publication has been carefully checked; no responsibility, however, is assumed for inaccuracies.

EXAR Corporation does not recommend the use of any of its products in life support applications where the failure or malfunction of the product can reasonably be expected to cause failure of the life support system or to significantly affect its safety or effectiveness. Products are not authorized for use in such applications unless EXAR Corporation receives, in writing, assurances to its satisfaction that: (a) the risk of injury or damage has been minimized; (b) the user assumes all such risks; (c) potential liability of EXAR Corporation is adequately protected under the circumstances.

Reproduction, in part or whole, without the prior written consent of EXAR Corporation is prohibited.