

P.C.B. HOLE DRILLINGS
(P.C.B. TOP SIDE)

(5:1)

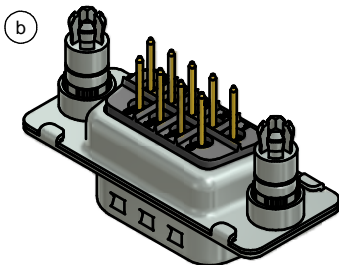
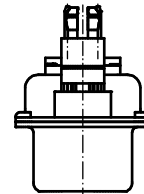
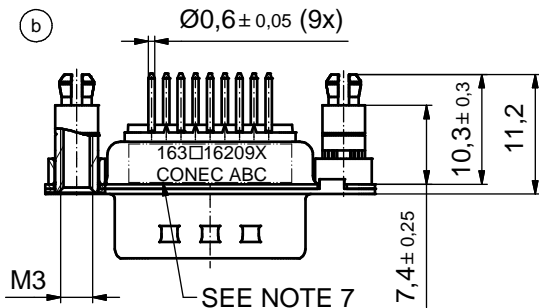
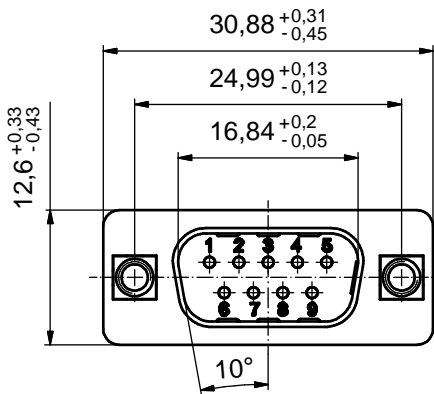
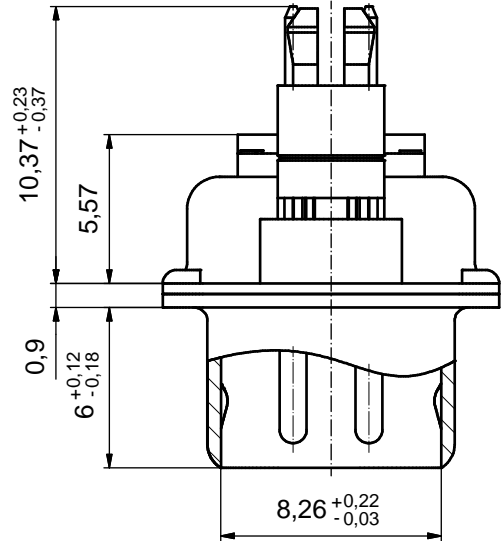

NOTES: (b)

1. METALHELLS: STEEL; min. 315µin TIN over 40-80µin NICKEL
2. INSULATORS: PBT GF UL 94 V-0, BLACK
3. CONTACTS: COPPER ALLOY; PLATING (SEE PART NO.):
 - PLEASE ADD A for GOLD FLASH over NICKEL (PREFERRED TYPE)
 - PLEASE ADD B for 20µin HARD GOLD over min. 50µin NICKEL
 - PLEASE ADD C for 30µin HARD GOLD over min. 50µin NICKEL
4. THREADED SPACER CLIPS:
 - COPPER ALLOY; min. 200µin TIN over 80µin NICKEL
 - PCB-HOLE: ϕ 3.1±0.1; PCB THICKNESS 1.6mm
5. COLLARS: COPPER ALLOY; min. 200µin TIN over 80µin NICKEL
6. MAXIMUM TORQUE VALUE FOR THREAD: 6 in.LB
7. CONNECTOR IS PART MARKED: 163□16209X CONEC ABC (see note 3)

Directive 2002/95/EC RoHS compliant

THIS DRAWING MAY NOT BE COPIED OR REPRODUCED IN ANY WAY, AND MAY NOT BE PASSED ON TO A THIRD PARTY WITHOUT WRITTEN PERMISSION. OWNERSHIP AND COPYRIGHT OF CONEC GmbH DO NOT ALTER CAD DRAWING BY HAND				tolerance		scale: 2:1 (5:1)
				date	name	material: see notes
				drawn	02.09.2014	Heinrich
				appd.	03.09.2014	Lehmenkühler
				norm		
				d-old	16K1A914	
				5 x b	Ä 5325	02.09.2014
			a	Original		
			rev.	description	date	name
			CONEC [®]			title: D-SUB MALE 9pos. SOLDER PIN STRAIGHT with threaded spacer clip
						dwg no: (b) 16K1A3508
						part no: (b) 163□16209X (see note 3)