

RECOMMENDED PCB LAYOUT: COMPONENT SIDE

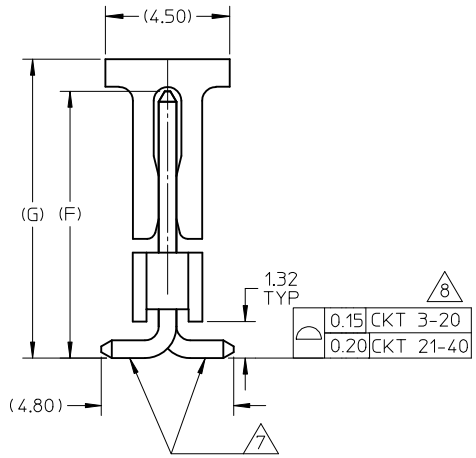

NOTES:

1. MATERIAL:
 - HSG: NYLON, GLASS-FILLED, UL94V-0, COLOR: BLACK
 - CAP: NYLON, GLASS-FILLED, UL94V-0, COLOR: BLACK
 - PIN: 0.64MM SQ, COPPER ALLOY
2. PLATING TYPE:
 - (1) GOLD FLASH OVER
1.25µm MIN. NICKEL OVERALL.
 - (2) GOLD FLASH ON CONTACT AND
2.50µm MIN. TIN ON SOLDER TAIL OVER
1.25µm MIN. NICKEL OVERALL.
 - (4) 0.38µm MIN. GOLD PLATE ON CONTACT AND
2.00µm MIN. TIN ON SOLDER TAIL OVER
1.25µm MIN. NICKEL OVERALL.
 - (5) 0.75µm MIN. GOLD PLATE ON CONTACT AND
2.00µm MIN. TIN ON SOLDER TAIL OVER
1.25µm MIN. NICKEL OVERALL.
 - (6) 2.50µm MIN. TIN OVERALL
1.25µm MIN. NICKEL OVERALL
3. PRODUCT SPECIFICATION: PS-87920-019
4. PACKAGING TYPE: SEE TABLE
5. PACKAGING SPEC:
 - TUBE WITH CAP VERSION: PK-89990-558
 - TUBE W/O CAP VERSION: PK-89990-545
 - EMBOSS TAPE WITH CAP: PK-89990-486
6. WAFER TO BE FLAT WITHIN 0.003 mm/mm
7. BEND DEPRESSION IS ACCEPTED SO LONG AS IT DOES NOT AFFECT THE OVERALL COPLANARITY OF TAIL
8. COPLANARITY IS TO BE MEASURED BY RESTING THE SOLDER TAIL ON A FLAT SURFACE
9. IRREGULAR CIRCUIT CUTOFF WITHIN BREAKAWAY SECTION IS PERMISSIBLE. CUTTING OR CHIPPING OF THE MAIN BODY IS NOT ACCEPTABLE
10. CAP LOCATION IS CENTERED ALONG THE MATING ENDS AS SHOWN. TOP SURFACE OF CAP TO BE FLAT FOR THE PURPOSE OF PICK & PLACE BY VACUUM SUCTION NOZZLE
11. RECOMMENDED PCB THICKNESS IS 1.60mm±0.10
12. THE ABOVE CKT 6 IS FOR ILLUSTRATION PURPOSE ONLY
13. TUBE LENGTH AS PER STANDARD 560mm

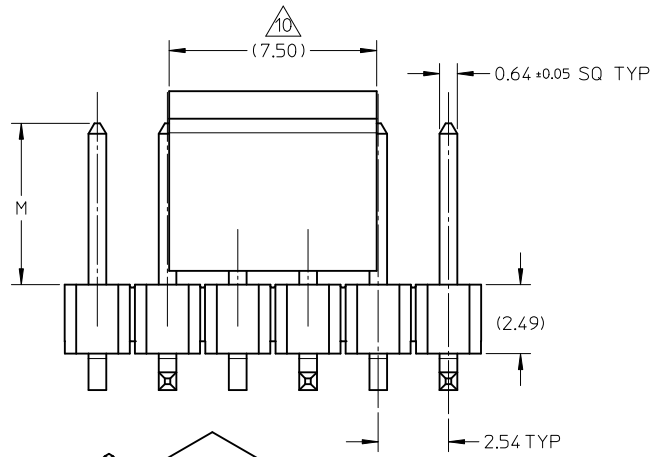
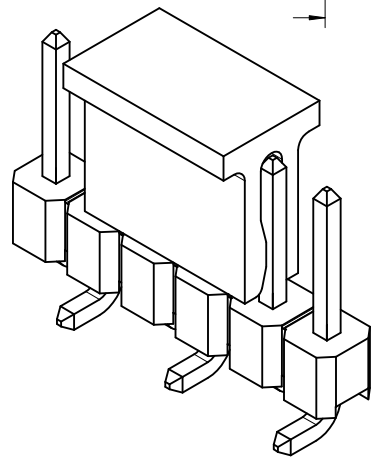

EWR#1228, +0209 EC NO: S2010-0966 DRWN:ATSEE 2010/05/20 CHK:DPJLIM 2005/03/29 APPR:MLONG 2010/06/08	QUALITY SYMBOLS $F_{\Delta} = 0$ $F_{\Delta} = 0$ $F_{\Delta} = 0$	GENERAL TOLERANCES (UNLESS SPECIFIED)		DIMENSION STYLE MM ONLY		SCALE NTS	DESIGN UNITS METRIC	THIRD ANGLE PROJECTION			
		4 PLACES ± --- ± --- 3 PLACES ± --- ± --- 2 PLACES ± 0.2 ± --- 1 PLACE ± --- ± ---	mm INCH	DRAWN BY YLQIAO	DATE 2005/03/14	TITLE CUSTOM HEADER 2.54MM PITCH SINGLE ROW SINGLE WAFER SMT HEADER					
		ANGULAR ± 3 °		CHECKED BY PTLIM	DATE 2005/03/29	MOLEX INCORPORATED					
		DRAFT WHERE APPLICABLE MUST REMAIN WITHIN DIMENSIONS		APPROVED BY MLONG	DATE 2010/03/10	MATERIAL NO. SEE TABLE	DOCUMENT NO. SD-87898-001	SHEET NO. 1 OF 20			

PACKAGING OPTION PART NO.

TRAY WITHOUT CAP	TRAY WITH CAP	TUBE WITHOUT CAP	TUBE WITH CAP	TAPE & REEL WITHOUT CAP	TAPE & REEL WITH CAP	CKT SIZE	VOID POSITION	PLATING TYPE	DIMENSION				
									A	B	G	F	M
87898-0204	-----	-----	-----	-----	-----	2	----	4	5.08	2.54	10.81	9.65	5.84
87898-0207	-----	-----	-----	-----	-----	2	----	5	5.08	2.54	10.81	9.65	5.84
-----	-----	-----	89990-0208	-----	87898-0209	2	----	6	5.08	2.54	10.81	9.65	5.84
87898-0301	-----	-----	-----	-----	-----	3	----	1	7.62	5.08	10.81	9.65	5.84
87898-0302	-----	-----	-----	-----	-----	3	----	2	7.62	5.08	10.81	9.65	5.84
87898-0304	-----	-----	-----	-----	-----	3	----	4	7.62	5.08	10.81	9.65	5.84
87898-0305	-----	-----	-----	-----	-----	3	----	5	7.62	5.08	10.81	9.65	5.84
87898-0306	-----	-----	-----	-----	-----	3	----	6	7.62	5.08	10.81	9.65	5.84

EWR#1228, +0209 EC NO: S2010-0966 DRW:ATSEE 2010/05/20 CHKD:PTLIM 2005/03/29 APPR:MLONG 2010/06/08	QUALITY SYMBOLS $F_A=0$ $F_G=0$ $F_P=0$	GENERAL TOLERANCES (UNLESS SPECIFIED)		DIMENSION STYLE MM ONLY		SCALE NTS	DESIGN UNITS METRIC	THIRD ANGLE PROJECTION		
			mm	INCH	DRAWN BY YLQIAO	DATE 2005/03/14	TITLE CUSTOM HEADER 2.54MM PITCH SINGLE ROW SINGLE WAFER SMT HEADER			
		4 PLACES	± ---	± ---	CHECKED BY PTLIM	DATE 2005/03/29	MOLEX INCORPORATED			
		3 PLACES	± ---	± ---	APPROVED BY MLONG	DATE 2010/03/10	DOCUMENT NO. SD-87898-001		SHEET NO. 2 OF 20	
2 PLACES	± 0.2	± ---	DRAFT WHERE APPLICABLE MUST REMAIN WITHIN DIMENSIONS		SEE TABLE		THIS DRAWING CONTAINS INFORMATION THAT IS PROPRIETARY TO MOLEX INCORPORATED AND SHOULD NOT BE USED WITHOUT WRITTEN PERMISSION			
1 PLACE	± ---	± ---								
		ANGULAR ± 3 °								

10 9 8 7 6 5 4 3 2 1

PACKAGING OPTION PART NO.						CKT SIZE	VOID POSITION	PLATING TYPE	DIMENSION				
TRAY WITHOUT CAP	TRAY WITH CAP	TUBE WITHOUT CAP	TUBE WITH CAP	TAPE & REEL WITHOUT CAP	TAPE & REEL WITH CAP				A	B	G	F	M
-----	-----	87898-0421	87898-0431	-----	87898-0451	4	-----	1	10.16	7.62	10.81	9.65	5.84
-----	-----	87898-0422	87898-0432	-----	87898-0452	4	-----	2	10.16	7.62	10.81	9.65	5.84
-----	-----	87898-0424	87898-0434	-----	87898-0454	4	-----	4	10.16	7.62	10.81	9.65	5.84
-----	-----	87898-0425	87898-0435	-----	87898-0455	4	-----	5	10.16	7.62	10.81	9.65	5.84
-----	-----	87898-0426	87898-0436	-----	87898-0456	4	-----	6	10.16	7.62	10.81	9.65	5.84
-----	-----	87898-0521	87898-0531	-----	87898-0551	5	-----	1	12.70	10.16	10.81	9.65	5.84
-----	-----	87898-0522	87898-0532	-----	87898-0552	5	-----	2	12.70	10.16	10.81	9.65	5.84
-----	-----	87898-0524	87898-0534	-----	87898-0554	5	-----	4	12.70	10.16	10.81	9.65	5.84
-----	-----	87898-0525	87898-0535	-----	87898-0555	5	-----	5	12.70	10.16	10.81	9.65	5.84
-----	-----	87898-0526	87898-0536	-----	87898-0556	5	-----	6	12.70	10.16	10.81	9.65	5.84
-----	-----	87898-0621	87898-0631	-----	87898-0651	6	-----	1	15.24	12.70	10.81	9.65	5.84
-----	-----	87898-0622	87898-0632	-----	87898-0652	6	-----	2	15.24	12.70	10.81	9.65	5.84
-----	-----	87898-0624	87898-0634	-----	87898-0654	6	-----	4	15.24	12.70	10.81	9.65	5.84
-----	-----	87898-0625	87898-0635	-----	87898-0655	6	-----	5	15.24	12.70	10.81	9.65	5.84
-----	-----	87898-0626	87898-0636	-----	87898-0656	6	-----	6	15.24	12.70	10.81	9.65	5.84

-----	-----	87898-0621	87898-0631	-----	87898-0651	6	-----	1	15.24	12.70	10.81	9.65	5.84
-----	-----	87898-0622	87898-0632	-----	87898-0652	6	-----	2	15.24	12.70	10.81	9.65	5.84
-----	-----	87898-0624	87898-0634	-----	87898-0654	6	-----	4	15.24	12.70	10.81	9.65	5.84
-----	-----	87898-0625	87898-0635	-----	87898-0655	6	-----	5	15.24	12.70	10.81	9.65	5.84
-----	-----	87898-0626	87898-0636	-----	87898-0656	6	-----	6	15.24	12.70	10.81	9.65	5.84

EWR#1228, +0209 EC NO: S2010-0966 DRW:ATSEE 2010/05/20 CHKD:PTLIM 2005/03/29 APPR:MLONG 2010/06/08	QUALITY SYMBOLS $\nabla_A = 0$ $\nabla_B = 0$ $\nabla_C = 0$	GENERAL TOLERANCES (UNLESS SPECIFIED)		DIMENSION STYLE MM ONLY		SCALE NTS	DESIGN UNITS METRIC	THIRD ANGLE PROJECTION		
			mm	INCH	DRAWN BY YLQIAO	DATE 2005/03/14	TITLE CUSTOM HEADER 2.54MM PITCH SINGLE ROW SINGLE WAFER SMT HEADER			
		4 PLACES	± ---	± ---	CHECKED BY PTLIM	DATE 2005/03/29				
		3 PLACES	± ---	± ---	APPROVED BY MLONG		DATE 2010/03/10	MOLEX INCORPORATED		MATERIAL NO. SEE TABLE
2 PLACES	± 0.2	± ---	ANGULAR ± 3 °		DOCUMENT NO. SD-87898-001		SHEET NO. 3 OF 20			
1 PLACE	± ---	± ---	DRAFT WHERE APPLICABLE MUST REMAIN WITHIN DIMENSIONS		THIS DRAWING CONTAINS INFORMATION THAT IS PROPRIETARY TO MOLEX INCORPORATED AND SHOULD NOT BE USED WITHOUT WRITTEN PERMISSION					

fb_frame_A3_P_AM_T Rev. F 2009/06/18 9 8 7 6 5 4 3 2 1

PACKAGING OPTION PART NO.						CKT SIZE	VOID POSITION	PLATING TYPE	DIMENSION				
TRAY WITHOUT CAP	TRAY WITH CAP	TUBE WITHOUT CAP	TUBE WITH CAP	TAPE & REEL WITHOUT CAP	TAPE & REEL WITH CAP				A	B	G	F	M
-----	-----	87898-0721	87898-0731	-----	87898-0751	7	-----	1	17.78	15.24	10.81	9.65	5.84
-----	-----	87898-0722	87898-0732	-----	87898-0752	7	-----	2	17.78	15.24	10.81	9.65	5.84
-----	-----	87898-0724	87898-0734	-----	87898-0754	7	-----	4	17.78	15.24	10.81	9.65	5.84
-----	-----	87898-0725	87898-0735	-----	87898-0755	7	-----	5	17.78	15.24	10.81	9.65	5.84
-----	-----	87898-0726	87898-0736	-----	87898-0756	7	-----	6	17.78	15.24	10.81	9.65	5.84
-----	-----	87898-0821	87898-0831	-----	87898-0851	8	-----	1	20.32	17.78	10.81	9.65	5.84
-----	-----	87898-0822	87898-0832	-----	87898-0852	8	-----	2	20.32	17.78	10.81	9.65	5.84
-----	-----	87898-0824	87898-0834	-----	87898-0854	8	-----	4	20.32	17.78	10.81	9.65	5.84
-----	-----	87898-0825	87898-0835	-----	87898-0855	8	-----	5	20.32	17.78	10.81	9.65	5.84
-----	-----	87898-0826	87898-0836	-----	87898-0856	8	-----	6	20.32	17.78	10.81	9.65	5.84
-----	-----	87898-0921	87898-0931	-----	87898-0951	9	-----	1	22.86	20.32	10.81	9.65	5.84
-----	-----	87898-0922	87898-0932	-----	87898-0952	9	-----	2	22.86	20.32	10.81	9.65	5.84
-----	-----	87898-0924	87898-0934	-----	87898-0954	9	-----	4	22.86	20.32	10.81	9.65	5.84
-----	-----	87898-0925	87898-0935	-----	87898-0955	9	-----	5	22.86	20.32	10.81	9.65	5.84
-----	-----	87898-0926	87898-0936	-----	87898-0956	9	-----	6	22.86	20.32	10.81	9.65	5.84

EWR#1228, +0209 EC NO: S2010-0966 DRW:ATSEE 2010/05/20 CHKD:PTLIM 2005/03/29 APPR:MLONG 2010/06/08	QUALITY SYMBOLS $F_A=0$ $F_G=0$ $F_P=0$	GENERAL TOLERANCES (UNLESS SPECIFIED)		DIMENSION STYLE MM ONLY		SCALE NTS	DESIGN UNITS METRIC	THIRD ANGLE PROJECTION			
				mm	INCH	DRAWN BY YLQIAO	DATE 2005/03/14	TITLE CUSTOM HEADER 2.54MM PITCH SINGLE ROW SINGLE WAFER SMT HEADER			
				4 PLACES	± ---	± ---	CHECKED BY PTLIM	DATE 2005/03/29	MOLEX INCORPORATED		
				3 PLACES	± ---	± ---	APPROVED BY MLONG	DATE 2010/03/10	DOCUMENT NO. SD-87898-001	SHEET NO. 4 OF 20	
		2 PLACES	± 0.2	± ---	DRAFT WHERE APPLICABLE MUST REMAIN WITHIN DIMENSIONS		SEE TABLE				
		1 PLACE	± ---	± ---	SIZE A3		THIS DRAWING CONTAINS INFORMATION THAT IS PROPRIETARY TO MOLEX INCORPORATED AND SHOULD NOT BE USED WITHOUT WRITTEN PERMISSION				
		ANGULAR ± 3 °									

PACKAGING OPTION PART NO.										DIMENSION				
TRAY WITHOUT CAP	TRAY WITH CAP	TUBE WITHOUT CAP	TUBE WITH CAP	TAPE & REEL WITHOUT CAP	TAPE & REEL WITH CAP	CKT SIZE	VOID POSITION	PLATING TYPE	A	B	G	F	M	
-----	-----	87898-1021	87898-1031	-----	87898-1051	10	-----	1	25.40	22.86	10.81	9.65	5.84	
-----	-----	87898-1022	87898-1032	-----	87898-1052	10	-----	2	25.40	22.86	10.81	9.65	5.84	
-----	-----	87898-1024	87898-1034	-----	87898-1054	10	-----	4	25.40	22.86	10.81	9.65	5.84	
-----	-----	87898-1025	87898-1035	-----	87898-1055	10	-----	5	25.40	22.86	10.81	9.65	5.84	
-----	-----	87898-1026	87898-1036	-----	87898-1056	10	-----	6	25.40	22.86	10.81	9.65	5.84	
-----	-----	87898-1121	87898-1131	-----	87898-1151	11	-----	1	27.94	25.40	10.81	9.65	5.84	
-----	-----	87898-1122	87898-1132	-----	87898-1152	11	-----	2	27.94	25.40	10.81	9.65	5.84	
-----	-----	87898-1124	87898-1134	-----	87898-1154	11	-----	4	27.94	25.40	10.81	9.65	5.84	
-----	-----	87898-1125	87898-1135	-----	87898-1155	11	-----	5	27.94	25.40	10.81	9.65	5.84	
-----	-----	87898-1126	87898-1136	-----	87898-1156	11	-----	6	27.94	25.40	10.81	9.65	5.84	
-----	-----	87898-1221	87898-1231	-----	87898-1251	12	-----	1	30.48	27.94	10.81	9.65	5.84	
-----	-----	87898-1222	87898-1232	-----	87898-1252	12	-----	2	30.48	27.94	10.81	9.65	5.84	
-----	-----	87898-1224	87898-1234	-----	87898-1254	12	-----	4	30.48	27.94	10.81	9.65	5.84	
-----	-----	87898-1225	87898-1235	-----	87898-1255	12	-----	5	30.48	27.94	10.81	9.65	5.84	
-----	-----	87898-1226	87898-1236	-----	87898-1256	12	-----	6	30.48	27.94	10.81	9.65	5.84	

E										F				
D										C				
B										A				

EWR#1228, +0209 EC NO: S2010-0966 DRW:ATSEE 2010/05/20 CH:KDPTLIM 2005/03/29 APPR:MLONG 2010/06/08	QUALITY SYMBOLS $\nabla_A = 0$ $\nabla_B = 0$ $\nabla_C = 0$	GENERAL TOLERANCES (UNLESS SPECIFIED)		DIMENSION STYLE MM ONLY		SCALE NTS	DESIGN UNITS METRIC	THIRD ANGLE PROJECTION			
		4 PLACES \pm --- \pm --- 3 PLACES \pm --- \pm --- 2 PLACES \pm 0.2 \pm --- 1 PLACE \pm --- \pm ---	mm INCH	DRAWN BY YLQIAO	DATE 2005/03/14	TITLE CUSTOM HEADER 2.54MM PITCH SINGLE ROW SINGLE WAFER SMT HEADER					
		ANGULAR \pm 3 °		CHECKED BY PTLIM	DATE 2005/03/29	APPROVED BY MLONG					
		DRAFT WHERE APPLICABLE MUST REMAIN WITHIN DIMENSIONS		SEE TABLE		MATERIAL NO. SD-87898-001	MOLEX INCORPORATED				SHEET NO. 5 OF 20

10 9 8 7 6 5 4 3 2 1

PACKAGING OPTION PART NO.						CKT SIZE	VOID POSITION	PLATING TYPE	DIMENSION				
TRAY WITHOUT CAP	TRAY WITH CAP	TUBE WITHOUT CAP	TUBE WITH CAP	TAPE & REEL WITHOUT CAP	TAPE & REEL WITH CAP				A	B	G	F	M
-----	-----	87898-1321	87898-1331	-----	87898-1351	13	-----	1	33.02	30.48	10.81	9.65	5.84
-----	-----	87898-1322	87898-1332	-----	87898-1352	13	-----	2	33.02	30.48	10.81	9.65	5.84
-----	-----	87898-1324	87898-1334	-----	87898-1354	13	-----	4	33.02	30.48	10.81	9.65	5.84
-----	-----	87898-1325	87898-1335	-----	87898-1355	13	-----	5	33.02	30.48	10.81	9.65	5.84
-----	-----	87898-1326	87898-1336	-----	87898-1356	13	-----	6	33.02	30.48	10.81	9.65	5.84
-----	-----	87898-1421	87898-1431	-----	87898-1451	14	-----	1	35.56	33.02	10.81	9.65	5.84
-----	-----	87898-1422	87898-1432	-----	87898-1452	14	-----	2	35.56	33.02	10.81	9.65	5.84
-----	-----	87898-1424	87898-1434	-----	87898-1454	14	-----	4	35.56	33.02	10.81	9.65	5.84
-----	-----	87898-1425	87898-1435	-----	87898-1455	14	-----	5	35.56	33.02	10.81	9.65	5.84
-----	-----	87898-1426	87898-1436	-----	87898-1456	14	-----	6	35.56	33.02	10.81	9.65	5.84
-----	-----	87898-1521	87898-1531	-----	87898-1551	15	-----	1	38.10	35.56	10.81	9.65	5.84
-----	-----	87898-1522	87898-1532	-----	87898-1552	15	-----	2	38.10	35.56	10.81	9.65	5.84
-----	-----	87898-1524	87898-1534	-----	87898-1554	15	-----	4	38.10	35.56	10.81	9.65	5.84
-----	-----	87898-1525	87898-1535	-----	87898-1555	15	-----	5	38.10	35.56	10.81	9.65	5.84
-----	-----	87898-1526	87898-1536	-----	87898-1556	15	-----	6	38.10	35.56	10.81	9.65	5.84

B

EWR#1228, +0209 EC NO: S2010-0966 DRWN:ATSEE 2010/05/20 CH'KD:PTLIM 2005/03/29 APPR:MLONG 2010/06/08	QUALITY SYMBOLS $\nabla_A = 0$ $\nabla_B = 0$ $\nabla_C = 0$	GENERAL TOLERANCES (UNLESS SPECIFIED)		DIMENSION STYLE MM ONLY		SCALE NTS	DESIGN UNITS METRIC	THIRD ANGLE PROJECTION			
				mm	INCH	DRAWN BY YLQIAO	DATE 2005/03/14	TITLE CUSTOM HEADER 2.54MM PITCH SINGLE ROW SINGLE WAFER SMT HEADER			
				4 PLACES \pm ---	\pm ---	CHECKED BY PTLIM	DATE 2005/03/29				
				3 PLACES \pm ---	\pm ---	APPROVED BY MLONG	DATE 2010/03/10	MOLEX MOLEX INCORPORATED			
		2 PLACES \pm 0.2	\pm ---	MATERIAL NO. SEE TABLE		DOCUMENT NO. SD-87898-001		SHEET NO. 6 OF 20			
		1 PLACE \pm ---	\pm ---	DRAFT WHERE APPLICABLE MUST REMAIN WITHIN DIMENSIONS		THIS DRAWING CONTAINS INFORMATION THAT IS PROPRIETARY TO MOLEX INCORPORATED AND SHOULD NOT BE USED WITHOUT WRITTEN PERMISSION					
		ANGULAR \pm 3 °									

A

ib_frame_A3_P_AM_T Rev. F 2009/06/18 9 8 7 6 5 4 3 2 1

PACKAGING OPTION PART NO.						CKT SIZE	VOID POSITION	PLATING TYPE	DIMENSION				
TRAY WITHOUT CAP	TRAY WITH CAP	TUBE WITHOUT CAP	TUBE WITH CAP	TAPE & REEL WITHOUT CAP	TAPE & REEL WITH CAP				A	B	G	F	M
-----	-----	87898-1621	87898-1631	-----	87898-1651	16	-----	1	40.64	38.10	10.81	9.65	5.84
-----	-----	87898-1622	87898-1632	-----	87898-1652	16	-----	2	40.64	38.10	10.81	9.65	5.84
-----	-----	87898-1624	87898-1634	-----	87898-1654	16	-----	4	40.64	38.10	10.81	9.65	5.84
-----	-----	87898-1625	87898-1635	-----	87898-1655	16	-----	5	40.64	38.10	10.81	9.65	5.84
-----	-----	87898-1626	87898-1636	-----	87898-1656	16	-----	6	40.64	38.10	10.81	9.65	5.84
-----	-----	87898-1721	87898-1731	-----	87898-1751	17	-----	1	43.18	40.64	10.81	9.65	5.84
-----	-----	87898-1722	87898-1732	-----	87898-1752	17	-----	2	43.18	40.64	10.81	9.65	5.84
-----	-----	87898-1724	87898-1734	-----	87898-1754	17	-----	4	43.18	40.64	10.81	9.65	5.84
-----	-----	87898-1725	87898-1735	-----	87898-1755	17	-----	5	43.18	40.64	10.81	9.65	5.84
-----	-----	87898-1726	87898-1736	-----	87898-1756	17	-----	6	43.18	40.64	10.81	9.65	5.84
-----	-----	87898-1821	87898-1831	-----	87898-1851	18	-----	1	45.72	43.18	10.81	9.65	5.84
-----	-----	87898-1822	87898-1832	-----	87898-1852	18	-----	2	45.72	43.18	10.81	9.65	5.84
-----	-----	87898-1824	87898-1834	-----	87898-1854	18	-----	4	45.72	43.18	10.81	9.65	5.84
-----	-----	87898-1825	87898-1835	-----	87898-1855	18	-----	5	45.72	43.18	10.81	9.65	5.84
-----	-----	87898-1826	87898-1836	-----	87898-1856	18	-----	6	45.72	43.18	10.81	9.65	5.84

--	--	--	--	--	--	--	--	--	--

EWR#1228, +0209 EC NO: S2010-0966 DRW:NATSEE 2010/05/20 CHKD:PTLIM 2005/03/29 APPR:MLONG 2010/06/08	QUALITY SYMBOLS $\nabla_A = 0$ $\nabla_G = 0$ $\nabla_P = 0$	GENERAL TOLERANCES (UNLESS SPECIFIED)		DIMENSION STYLE MM ONLY		SCALE NTS	DESIGN UNITS METRIC	THIRD ANGLE PROJECTION			
		4 PLACES \pm --- \pm --- 3 PLACES \pm --- \pm --- 2 PLACES \pm 0.2 \pm --- 1 PLACE \pm --- \pm ---	mm INCH	DRAWN BY YLQIAO	DATE 2005/03/14	TITLE CUSTOM HEADER 2.54MM PITCH SINGLE ROW SINGLE WAFER SMT HEADER					
		ANGULAR \pm 3 °		CHECKED BY PTLIM	DATE 2005/03/29	MOLEX INCORPORATED					
		DRAFT WHERE APPLICABLE MUST REMAIN WITHIN DIMENSIONS		APPROVED BY MLONG	DATE 2010/03/10	MATERIAL NO. SEE TABLE		DOCUMENT NO. SD-87898-001	SHEET NO. 7 OF 20		

PACKAGING OPTION PART NO.						CKT SIZE	VOID POSITION	PLATING TYPE	DIMENSION				
TRAY WITHOUT CAP	TRAY WITH CAP	TUBE WITHOUT CAP	TUBE WITH CAP	TAPE & REEL WITHOUT CAP	TAPE & REEL WITH CAP				A	B	G	F	M
-----	-----	87898-1921	87898-1931	-----	87898-1951	19	----	1	48.26	45.72	10.81	9.65	5.84
-----	-----	87898-1922	87898-1932	-----	87898-1952	19	----	2	48.26	45.72	10.81	9.65	5.84
-----	-----	87898-1924	87898-1934	-----	87898-1954	19	----	4	48.26	45.72	10.81	9.65	5.84
-----	-----	87898-1925	87898-1935	-----	87898-1955	19	----	5	48.26	45.72	10.81	9.65	5.84
-----	-----	87898-1926	87898-1936	-----	87898-1956	19	----	6	48.26	45.72	10.81	9.65	5.84
-----	-----	87898-2021	87898-2031	-----	87898-2051	20	----	1	50.80	48.26	10.81	9.65	5.84
-----	-----	87898-2022	87898-2032	-----	87898-2052	20	----	2	50.80	48.26	10.81	9.65	5.84
-----	-----	87898-2024	87898-2034	-----	87898-2054	20	----	4	50.80	48.26	10.81	9.65	5.84
-----	-----	87898-2025	87898-2035	-----	87898-2055	20	----	5	50.80	48.26	10.81	9.65	5.84
-----	-----	87898-2026	87898-2036	-----	87898-2056	20	----	6	50.80	48.26	10.81	9.65	5.84
-----	-----	87898-2121	87898-2131	-----	87898-2151	21	----	1	53.34	50.80	10.81	9.65	5.84
-----	-----	87898-2122	87898-2132	-----	87898-2152	21	----	2	53.34	50.80	10.81	9.65	5.84
-----	-----	87898-2124	87898-2134	-----	87898-2154	21	----	4	53.34	50.80	10.81	9.65	5.84
-----	-----	87898-2125	87898-2135	-----	87898-2155	21	----	5	53.34	50.80	10.81	9.65	5.84
-----	-----	87898-2126	87898-2136	-----	87898-2156	21	----	6	53.34	50.80	10.81	9.65	5.84

-----	-----	87898-2201	87898-2211	-----	87898-2251	22	----	1	55.88	53.34	10.81	9.65	5.84
-----	-----	87898-2202	87898-2212	-----	87898-2252	22	----	2	55.88	53.34	10.81	9.65	5.84
-----	-----	87898-2204	87898-2214	-----	87898-2254	22	----	4	55.88	53.34	10.81	9.65	5.84
-----	-----	87898-2205	87898-2215	-----	87898-2255	22	----	5	55.88	53.34	10.81	9.65	5.84
-----	-----	87898-2206	87898-2216	-----	87898-2256	22	----	6	55.88	53.34	10.81	9.65	5.84

EWR#1228, +0209 EC NO: S2010-0966 DRW:ATSEE 2010/05/20 CH:KDPTLIM 2005/03/29 APPR:MLONG 2010/06/08	QUALITY SYMBOLS $\nabla_A = 0$ $\nabla_F = 0$ $\nabla_P = 0$	GENERAL TOLERANCES (UNLESS SPECIFIED)		DIMENSION STYLE MM ONLY		SCALE NTS	DESIGN UNITS METRIC	THIRD ANGLE PROJECTION			
		4 PLACES \pm --- \pm --- 3 PLACES \pm --- \pm --- 2 PLACES \pm 0.2 \pm --- 1 PLACE \pm --- \pm ---	mm INCH	DRAWN BY YLQIAO	DATE 2005/03/14	TITLE CUSTOM HEADER 2.54MM PITCH SINGLE ROW SINGLE WAFER SMT HEADER					
		ANGULAR \pm 3 °		CHECKED BY PTLIM	DATE 2005/03/29	APPROVED BY MLONG					
		DRAFT WHERE APPLICABLE MUST REMAIN WITHIN DIMENSIONS		MATERIAL NO. SEE TABLE		DATE 2010/03/10	MOLEX INCORPORATED		DOCUMENT NO. SD-87898-001	SHEET NO. 8 OF 20	

10 | 9 | 8 | 7 | 6 | 5 | 4 | 3 | 2 | 1

PACKAGING OPTION PART NO.						CKT SIZE	VOID POSITION	PLATING TYPE	DIMENSION				
TRAY WITHOUT CAP	TRAY WITH CAP	TUBE WITHOUT CAP	TUBE WITH CAP	TAPE & REEL WITHOUT CAP	TAPE & REEL WITH CAP				A	B	G	F	M
-----	-----	87898-2221	87898-2231	-----	-----	22	----	1	55.88	53.34	10.81	9.65	5.84
-----	-----	87898-2222	87898-2232	-----	-----	22	----	2	55.88	53.34	10.81	9.65	5.84
-----	-----	87898-2224	87898-2234	-----	-----	22	----	4	55.88	53.34	10.81	9.65	5.84
-----	-----	87898-2225	87898-2235	-----	-----	22	----	5	55.88	53.34	10.81	9.65	5.84
-----	-----	87898-2226	87898-2236	-----	-----	22	----	6	55.88	53.34	10.81	9.65	5.84
-----	-----												
-----	-----	87898-2321	87898-2331	-----	-----	23	----	1	58.42	55.88	10.81	9.65	5.84
-----	-----	87898-2322	87898-2332	-----	-----	23	----	2	58.42	55.88	10.81	9.65	5.84
-----	-----	87898-2324	87898-2334	-----	-----	23	----	4	58.42	55.88	10.81	9.65	5.84
-----	-----	87898-2325	87898-2335	-----	-----	23	----	5	58.42	55.88	10.81	9.65	5.84
-----	-----	87898-2326	87898-2336	-----	-----	23	----	6	58.42	55.88	10.81	9.65	5.84
-----	-----												
-----	-----	87898-2421	87898-2431	-----	-----	24	----	1	60.96	58.42	10.81	9.65	5.84
-----	-----	87898-2422	87898-2432	-----	-----	24	----	2	60.96	58.42	10.81	9.65	5.84
-----	-----	87898-2424	87898-2434	-----	-----	24	----	4	60.96	58.42	10.81	9.65	5.84
-----	-----	87898-2425	87898-2435	-----	-----	24	----	5	60.96	58.42	10.81	9.65	5.84
-----	-----	87898-2426	87898-2436	-----	-----	24	----	6	60.96	58.42	10.81	9.65	5.84

B

EWR#1228, +0209 EC NO: S2010-0966 DRW:ATSEE 2010/05/20 CHKD:PTLIM 2005/03/29 APPR:MLONG 2010/06/08	QUALITY SYMBOLS $\nabla_F = 0$ $\nabla_E = 0$ $\nabla_D = 0$	GENERAL TOLERANCES (UNLESS SPECIFIED)		DIMENSION STYLE MM ONLY		SCALE NTS	DESIGN UNITS METRIC	THIRD ANGLE PROJECTION	
		4 PLACES \pm --- \pm --- 3 PLACES \pm --- \pm --- 2 PLACES \pm 0.2 \pm --- 1 PLACE \pm --- \pm ---	mm INCH	DRAWN BY YLQIAO	DATE 2005/03/14	TITLE CUSTOM HEADER 2.54MM PITCH SINGLE ROW SINGLE WAFER SMT HEADER			
		ANGULAR \pm 3 °		CHECKED BY PTLIM	DATE 2005/03/29	MOLEX INCORPORATED			
		DRAFT WHERE APPLICABLE MUST REMAIN WITHIN DIMENSIONS		APPROVED BY MLONG	DATE 2010/03/10	MATERIAL NO. SEE TABLE	DOCUMENT NO. SD-87898-001	SHEET NO. 9 OF 20	

A

fb_frame_A3_P_AM_T Rev. F 2009/06/18 | 9 | 8 | 7 | 6 | 5 | 4 | 3 | 2 | 1

10 | 9 | 8 | 7 | 6 | 5 | 4 | 3 | 2 | 1

PACKAGING OPTION PART NO.						CKT SIZE	VOID POSITION	PLATING TYPE	DIMENSION				
TRAY WITHOUT CAP	TRAY WITH CAP	TUBE WITHOUT CAP	TUBE WITH CAP	TAPE & REEL WITHOUT CAP	TAPE & REEL WITH CAP				A	B	G	F	M
-----	-----	87898-2521	87898-2531	-----	-----	25	----	1	63.50	60.96	10.81	9.65	5.84
-----	-----	87898-2522	87898-2532	-----	-----	25	----	2	63.50	60.96	10.81	9.65	5.84
-----	-----	87898-2524	87898-2534	-----	-----	25	----	4	63.50	60.96	10.81	9.65	5.84
-----	-----	87898-2525	87898-2535	-----	-----	25	----	5	63.50	60.96	10.81	9.65	5.84
-----	-----	87898-2526	87898-2536	-----	-----	25	----	6	63.50	60.96	10.81	9.65	5.84
-----	-----	87898-2621	87898-2631	-----	-----	26	----	1	66.04	63.50	10.81	9.65	5.84
-----	-----	87898-2622	87898-2632	-----	-----	26	----	2	66.04	63.50	10.81	9.65	5.84
-----	-----	87898-2624	87898-2634	-----	-----	26	----	4	66.04	63.50	10.81	9.65	5.84
-----	-----	87898-2625	87898-2635	-----	-----	26	----	5	66.04	63.50	10.81	9.65	5.84
-----	-----	87898-2626	87898-2636	-----	-----	26	----	6	66.04	63.50	10.81	9.65	5.84
-----	-----	87898-2721	87898-2731	-----	-----	27	----	1	68.58	66.04	10.81	9.65	5.84
-----	-----	87898-2722	87898-2732	-----	-----	27	----	2	68.58	66.04	10.81	9.65	5.84
-----	-----	87898-2724	87898-2734	-----	-----	27	----	4	68.58	66.04	10.81	9.65	5.84
-----	-----	87898-2725	87898-2735	-----	-----	27	----	5	68.58	66.04	10.81	9.65	5.84
-----	-----	87898-2726	87898-2736	-----	-----	27	----	6	68.58	66.04	10.81	9.65	5.84

B

EWR#1228, +0209 EC NO: S2010-0966 DRW:NATSEE 2010/05/20 CHKD:PTLIM 2005/03/29 APPR:MLONG 2010/06/08	QUALITY SYMBOLS $\nabla_A = 0$ $\nabla_B = 0$ $\nabla_C = 0$	GENERAL TOLERANCES (UNLESS SPECIFIED)		DIMENSION STYLE MM ONLY		SCALE NTS	DESIGN UNITS METRIC	THIRD ANGLE PROJECTION		
			mm	INCH	DRAWN BY YLQIAO	DATE 2005/03/14	TITLE CUSTOM HEADER 2.54MM PITCH SINGLE ROW SINGLE WAFER SMT HEADER			
		4 PLACES	± ---	± ---	CHECKED BY PTLIM	DATE 2005/03/29				
		3 PLACES	± ---	± ---	APPROVED BY MLONG		DATE 2010/03/10	MOLEX INCORPORATED		MATERIAL NO. SEE TABLE
2 PLACES	± 0.2	± ---	DRAFT WHERE APPLICABLE MUST REMAIN WITHIN DIMENSIONS		DOCUMENT NO. SD-87898-001	SHEET NO. 10 OF 20				
1 PLACE	± ---	± ---			THIS DRAWING CONTAINS INFORMATION THAT IS PROPRIETARY TO MOLEX INCORPORATED AND SHOULD NOT BE USED WITHOUT WRITTEN PERMISSION					

A

fb_frame_A3_P_AM_T Rev. F 2009/06/18 | 9 | 8 | 7 | 6 | 5 | 4 | 3 | 2 | 1

PACKAGING OPTION PART NO.						CKT SIZE	VOID POSITION	PLATING TYPE	DIMENSION				
TRAY WITHOUT CAP	TRAY WITH CAP	TUBE WITHOUT CAP	TUBE WITH CAP	TAPE & REEL WITHOUT CAP	TAPE & REEL WITH CAP				A	B	G	F	M
-----	-----	87898-2821	87898-2831	-----	-----	28	----	1	71.12	68.58	10.81	9.65	5.84
-----	-----	87898-2822	87898-2832	-----	-----	28	----	2	71.12	68.58	10.81	9.65	5.84
-----	-----	87898-2824	87898-2834	-----	-----	28	----	4	71.12	68.58	10.81	9.65	5.84
-----	-----	87898-2825	87898-2835	-----	-----	28	----	5	71.12	68.58	10.81	9.65	5.84
-----	-----	87898-2826	87898-2836	-----	-----	28	----	6	71.12	68.58	10.81	9.65	5.84
-----	-----	87898-2921	87898-2931	-----	-----	29	----	1	73.66	71.12	10.81	9.65	5.84
-----	-----	87898-2922	87898-2932	-----	-----	29	----	2	73.66	71.12	10.81	9.65	5.84
-----	-----	87898-2924	87898-2934	-----	-----	29	----	4	73.66	71.12	10.81	9.65	5.84
-----	-----	87898-2925	87898-2935	-----	-----	29	----	5	73.66	71.12	10.81	9.65	5.84
-----	-----	87898-2926	87898-2936	-----	-----	29	----	6	73.66	71.12	10.81	9.65	5.84
-----	-----	87898-3021	87898-3031	-----	-----	30	----	1	76.20	73.66	10.81	9.65	5.84
-----	-----	87898-3022	87898-3032	-----	-----	30	----	2	76.20	73.66	10.81	9.65	5.84
-----	-----	87898-3024	87898-3034	-----	-----	30	----	4	76.20	73.66	10.81	9.65	5.84
-----	-----	87898-3025	87898-3035	-----	-----	30	----	5	76.20	73.66	10.81	9.65	5.84
-----	-----	87898-3026	87898-3036	-----	-----	30	----	6	76.20	73.66	10.81	9.65	5.84

-----	-----	87898-3201	87898-3231	-----	-----	32	----	1	79.20	76.66	10.81	9.65	5.84
-----	-----	87898-3202	87898-3232	-----	-----	32	----	2	79.20	76.66	10.81	9.65	5.84
-----	-----	87898-3204	87898-3234	-----	-----	32	----	4	79.20	76.66	10.81	9.65	5.84
-----	-----	87898-3205	87898-3235	-----	-----	32	----	5	79.20	76.66	10.81	9.65	5.84
-----	-----	87898-3206	87898-3236	-----	-----	32	----	6	79.20	76.66	10.81	9.65	5.84

EWR#1228, +0209 EC NO: S2010-0966 DRW:ATSEE 2010/05/20 CHKD:PTLIM 2005/03/29 APPR:MLONG 2010/06/08	REV DESCRIPTION B3	QUALITY SYMBOLS	GENERAL TOLERANCES (UNLESS SPECIFIED)	DIMENSION STYLE	SCALE	DESIGN UNITS	THIRD ANGLE PROJECTION	
		$\nabla_A = 0$ $\nabla_G = 0$ $\nabla_P = 0$	mm INCH 4 PLACES ± --- ± --- 3 PLACES ± --- ± --- 2 PLACES ± 0.2 ± --- 1 PLACE ± --- ± --- ANGULAR ± 3 °	MM ONLY	NTS	METRIC	DRAWN BY: YLQIAO DATE: 2005/03/14 CHECKED BY: PTLIM DATE: 2005/03/29 APPROVED BY: MLONG DATE: 2010/03/10	TITLE: CUSTOM HEADER 2.54MM PITCH SINGLE ROW SINGLE WAFER SMT HEADER
		DRAFT WHERE APPLICABLE MUST REMAIN WITHIN DIMENSIONS		SEE TABLE	MOLEX INCORPORATED DOCUMENT NO. SD-87898-001		SHEET NO. 11 OF 20	
		THIS DRAWING CONTAINS INFORMATION THAT IS PROPRIETARY TO MOLEX INCORPORATED AND SHOULD NOT BE USED WITHOUT WRITTEN PERMISSION						

PACKAGING OPTION PART NO.

F	PACKAGING OPTION PART NO.						CKT SIZE	VOID POSITION	PLATING TYPE	DIMENSION				
	TRAY WITHOUT CAP	TRAY WITH CAP	TUBE WITHOUT CAP	TUBE WITH CAP	TAPE & REEL WITHOUT CAP	TAPE & REEL WITH CAP				A	B	G	F	M
	-----	-----	87898-3121	87898-3131	-----	-----	31	----	1	78.74	76.20	10.81	9.65	5.84
	-----	-----	87898-3122	87898-3132	-----	-----	31	----	2	78.74	76.20	10.81	9.65	5.84
	-----	-----	87898-3124	87898-3134	-----	-----	31	----	4	78.74	76.20	10.81	9.65	5.84
	-----	-----	87898-3125	87898-3135	-----	-----	31	----	5	78.74	76.20	10.81	9.65	5.84
	-----	-----	87898-3126	87898-3136	-----	-----	31	----	6	78.74	76.20	10.81	9.65	5.84
E														
	-----	-----	87898-3221	87898-3231	-----	-----	32	----	1	81.28	78.74	10.81	9.65	5.84
	-----	-----	87898-3222	87898-3232	-----	-----	32	----	2	81.28	78.74	10.81	9.65	5.84
	-----	-----	87898-3224	87898-3234	-----	-----	32	----	4	81.28	78.74	10.81	9.65	5.84
	-----	-----	87898-3225	87898-3235	-----	-----	32	----	5	81.28	78.74	10.81	9.65	5.84
D														
	-----	-----	87898-3226	87898-3236	-----	-----	32	----	6	81.28	78.74	10.81	9.65	5.84
	-----	-----	87898-3321	87898-3331	-----	-----	33	----	1	83.82	81.28	10.81	9.65	5.84
	-----	-----	87898-3322	87898-3332	-----	-----	33	----	2	83.82	81.28	10.81	9.65	5.84
	-----	-----	87898-3324	87898-3334	-----	-----	33	----	4	83.82	81.28	10.81	9.65	5.84
	-----	-----	87898-3325	87898-3335	-----	-----	33	----	5	83.82	81.28	10.81	9.65	5.84
C														
	-----	-----	87898-3326	87898-3336	-----	-----	33	----	6	83.82	81.28	10.81	9.65	5.84

EWR#1228, +0209 EC NO: S2010-0966 DRW:ATSEE 2010/05/20 CH:KD:PTLIM 2005/03/29 APPR:MLONG 2010/06/08	QUALITY SYMBOLS $\nabla_A = 0$ $\nabla_C = 0$ $\nabla_P = 0$	GENERAL TOLERANCES (UNLESS SPECIFIED)		DIMENSION STYLE MM ONLY		SCALE NTS	DESIGN UNITS METRIC	THIRD ANGLE PROJECTION			
				mm	INCH	DRAWN BY YLQIAO	DATE 2005/03/14	TITLE CUSTOM HEADER 2.54MM PITCH SINGLE ROW SINGLE WAFER SMT HEADER			
				4 PLACES ± ---	± ---	CHECKED BY PTLIM	DATE 2005/03/29				
				3 PLACES ± ---	± ---	APPROVED BY MLONG	DATE 2010/03/10	 MOLEX INCORPORATED DOCUMENT NO. SD-87898-001			
		2 PLACES ± 0.2	± ---	DRAFT WHERE APPLICABLE MUST REMAIN WITHIN DIMENSIONS		SHEET NO. 12 OF 20					
		1 PLACE ± ---	± ---	SEE TABLE		THIS DRAWING CONTAINS INFORMATION THAT IS PROPRIETARY TO MOLEX INCORPORATED AND SHOULD NOT BE USED WITHOUT WRITTEN PERMISSION					
		ANGULAR ± 3 °		SIZE A3							

PACKAGING OPTION PART NO.										DIMENSION				
TRAY WITHOUT CAP	TRAY WITH CAP	TUBE WITHOUT CAP	TUBE WITH CAP	TAPE & REEL WITHOUT CAP	TAPE & REEL WITH CAP	CKT SIZE	VOID POSITION	PLATING TYPE	A	B	G	F	M	
-----	-----	87898-3421	87898-3431	-----	-----	34	----	1	86.36	83.82	10.81	9.65	5.84	
-----	-----	87898-3422	87898-3432	-----	-----	34	----	2	86.36	83.82	10.81	9.65	5.84	
-----	-----	87898-3424	87898-3434	-----	-----	34	----	4	86.36	83.82	10.81	9.65	5.84	
-----	-----	87898-3425	87898-3435	-----	-----	34	----	5	86.36	83.82	10.81	9.65	5.84	
-----	-----	87898-3426	87898-3436	-----	-----	34	----	6	86.36	83.82	10.81	9.65	5.84	
-----	-----	87898-3521	87898-3531	-----	-----	35	----	1	88.90	86.36	10.81	9.65	5.84	
-----	-----	87898-3522	87898-3532	-----	-----	35	----	2	88.90	86.36	10.81	9.65	5.84	
-----	-----	87898-3524	87898-3534	-----	-----	35	----	4	88.90	86.36	10.81	9.65	5.84	
-----	-----	87898-3525	87898-3535	-----	-----	35	----	5	88.90	86.36	10.81	9.65	5.84	
-----	-----	87898-3526	87898-3536	-----	-----	35	----	6	88.90	86.36	10.81	9.65	5.84	
-----	-----	87898-3621	87898-3631	-----	-----	36	----	1	91.44	88.90	10.81	9.65	5.84	
-----	-----	87898-3622	87898-3632	-----	-----	36	----	2	91.44	88.90	10.81	9.65	5.84	
-----	-----	87898-3624	87898-3634	-----	-----	36	----	4	91.44	88.90	10.81	9.65	5.84	
-----	-----	87898-3625	87898-3635	-----	-----	36	----	5	91.44	88.90	10.81	9.65	5.84	
-----	-----	87898-3626	87898-3636	-----	-----	36	----	6	91.44	88.90	10.81	9.65	5.84	

B

EWR#1228, +0209 EC NO: S2010-0966 DRWN:ATSEE 2010/05/20 CH'KD:PTLIM 2005/03/29 APPR:MLONG 2010/06/08	QUALITY SYMBOLS $\nabla_A = 0$ $\nabla_B = 0$ $\nabla_C = 0$	GENERAL TOLERANCES (UNLESS SPECIFIED)		DIMENSION STYLE MM ONLY		SCALE NTS	DESIGN UNITS METRIC	THIRD ANGLE PROJECTION			
				mm	INCH	DRAWN BY YLQIAO	DATE 2005/03/14	TITLE CUSTOM HEADER 2.54MM PITCH SINGLE ROW SINGLE WAFER SMT HEADER			
				4 PLACES \pm ---	\pm ---	CHECKED BY PTLIM	DATE 2005/03/29				
				3 PLACES \pm ---	\pm ---	APPROVED BY MLONG	DATE 2010/03/10	MOLEX INCORPORATED DOCUMENT NO. SD-87898-001 SHEET NO. 13 OF 20			
		2 PLACES \pm 0.2	\pm ---	MATERIAL NO. SEE TABLE							
		1 PLACE \pm ---	\pm ---	ANGULAR \pm 3 °		THIS DRAWING CONTAINS INFORMATION THAT IS PROPRIETARY TO MOLEX INCORPORATED AND SHOULD NOT BE USED WITHOUT WRITTEN PERMISSION					
		DRAFT WHERE APPLICABLE MUST REMAIN WITHIN DIMENSIONS									

PACKAGING OPTION PART NO.

F

E

D

C

B

A

F

E

D

C

B

A

TRAY WITHOUT CAP	TRAY WITH CAP	TUBE WITHOUT CAP	TUBE WITH CAP	TAPE & REEL WITHOUT CAP	TAPE & REEL WITH CAP	CKT SIZE	VOID POSITION	PLATING TYPE	DIMENSION				
									A	B	G	F	M
-----	-----	87898-3721	87898-3731	-----	-----	37	-----	1	93.98	91.44	10.81	9.65	5.84
-----	-----	87898-3722	87898-3732	-----	-----	37	-----	2	93.98	91.44	10.81	9.65	5.84
-----	-----	87898-3724	87898-3734	-----	-----	37	-----	4	93.98	91.44	10.81	9.65	5.84
-----	-----	87898-3725	87898-3735	-----	-----	37	-----	5	93.98	91.44	10.81	9.65	5.84
-----	-----	87898-3726	87898-3736	-----	-----	37	-----	6	93.98	91.44	10.81	9.65	5.84
-----	-----	87898-3821	87898-3831	-----	-----	38	-----	1	96.52	93.98	10.81	9.65	5.84
-----	-----	87898-3822	87898-3832	-----	-----	38	-----	2	96.52	93.98	10.81	9.65	5.84
-----	-----	87898-3824	87898-3834	-----	-----	38	-----	4	96.52	93.98	10.81	9.65	5.84
-----	-----	87898-3825	87898-3835	-----	-----	38	-----	5	96.52	93.98	10.81	9.65	5.84
-----	-----	87898-3826	87898-3836	-----	-----	38	-----	6	96.52	93.98	10.81	9.65	5.84
-----	-----	87898-3921	87898-3931	-----	-----	39	-----	1	99.06	96.52	10.81	9.65	5.84
-----	-----	87898-3922	87898-3932	-----	-----	39	-----	2	99.06	96.52	10.81	9.65	5.84
-----	-----	87898-3924	87898-3934	-----	-----	39	-----	4	99.06	96.52	10.81	9.65	5.84
-----	-----	87898-3925	87898-3935	-----	-----	39	-----	5	99.06	96.52	10.81	9.65	5.84
-----	-----	87898-3926	87898-3936	-----	-----	39	-----	6	99.06	96.52	10.81	9.65	5.84

EWR#1228, +0209 EC NO: S2010-0966 DRW:ATSEE 2010/05/20 CHKD:PTLIM 2005/03/29 APPR:MLONG 2010/06/08	QUALITY SYMBOLS $F_A=0$ $F_G=0$ $F_P=0$	GENERAL TOLERANCES (UNLESS SPECIFIED)		DIMENSION STYLE MM ONLY		SCALE NTS	DESIGN UNITS METRIC	THIRD ANGLE PROJECTION			
		4 PLACES ± --- ± ---	mm INCH	DRAWN BY YLQIAO	DATE 2005/03/14	TITLE CUSTOM HEADER 2.54MM PITCH SINGLE ROW SINGLE WAFER SMT HEADER					
		3 PLACES ± --- ± ---		CHECKED BY PTLIM	DATE 2005/03/29	MOLEX INCORPORATED					
		2 PLACES ± 0.2 ± ---		APPROVED BY MLONG	DATE 2010/03/10	DOCUMENT NO. SD-87898-001					
1 PLACE ± --- ± ---		ANGULAR ± 3 °		MATERIAL NO. SEE TABLE		SHEET NO. 14 OF 20					
DRAFT WHERE APPLICABLE MUST REMAIN WITHIN DIMENSIONS		THIS DRAWING CONTAINS INFORMATION THAT IS PROPRIETARY TO MOLEX INCORPORATED AND SHOULD NOT BE USED WITHOUT WRITTEN PERMISSION									

PACKAGING OPTION PART NO.						CKT SIZE	VOID POSITION	PLATING TYPE	DIMENSION				
TRAY WITHOUT CAP	TRAY WITH CAP	TUBE WITHOUT CAP	TUBE WITH CAP	TAPE & REEL WITHOUT CAP	TAPE & REEL WITH CAP				A	B	G	F	M
-----	-----	87898-4021	87898-4031	-----	-----	40	----	1	101.6	99.06	10.81	9.65	5.84
-----	-----	87898-4022	87898-4032	-----	-----	40	----	2	101.6	99.06	10.81	9.65	5.84
-----	-----	87898-4024	87898-4034	-----	-----	40	----	4	101.6	99.06	10.81	9.65	5.84
-----	-----	87898-4025	87898-4035	-----	-----	40	----	5	101.6	99.06	10.81	9.65	5.84
-----	-----	87898-4026	87898-4036	-----	-----	40	----	6	101.6	99.06	10.81	9.65	5.84

EWR#1228, +0209 EC NO: S2010-0966 DRW:ATSEE 2010/05/20 CHK:DPILIM 2005/03/29 APPR:MLONG 2010/06/08	QUALITY SYMBOLS	GENERAL TOLERANCES (UNLESS SPECIFIED)		DIMENSION STYLE MM ONLY		SCALE NTS	DESIGN UNITS METRIC	THIRD ANGLE PROJECTION	
	$\nabla_A = 0$	4 PLACES	mm	INCH	DRAWN BY	DATE	TITLE		
	$\nabla_C = 0$	3 PLACES	± ---	± ---	YLOIAO	2005/03/14	CUSTOM HEADER		
	$\nabla_P = 0$	2 PLACES	± 0.2	± ---	CHECKED BY	DATE	2.54MM PITCH SINGLE ROW		
		1 PLACE	± ---	± ---	PTLIM	2005/03/29	SINGLE WAFER SMT HEADER		
	ANGULAR ± 3 °				APPROVED BY	DATE	MOLEX MOLEX INCORPORATED		
	DRAFT WHERE APPLICABLE MUST REMAIN WITHIN DIMENSIONS		SEE TABLE		MLONG	2010/03/10	DOCUMENT NO.		SHEET NO.
				SIZE A3		THIS DRAWING CONTAINS INFORMATION THAT IS PROPRIETARY TO MOLEX INCORPORATED AND SHOULD NOT BE USED WITHOUT WRITTEN PERMISSION			SD-87898-001 15 OF 20

**PART WITHOUT CAP
IN TUBE ORIENTATION**

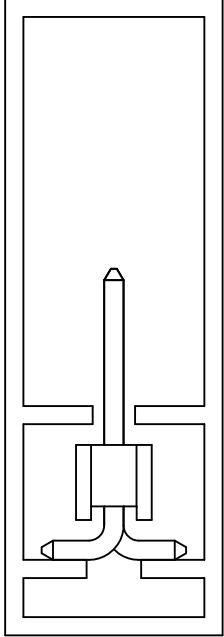

**PART WITH CAP
IN TUBE ORIENTATION**

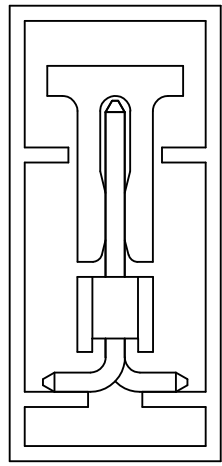

EWR#1228, +0209 IEC NO: S2010-0966 DRWN:ATSEE 2010/05/20 CHYKD:PTLIM 2005/03/29 APPR:MLONG 2010/06/08	B3	DESCRIPTION REV	QUALITY SYMBOLS	GENERAL TOLERANCES (UNLESS SPECIFIED)	DIMENSION STYLE	SCALE	DESIGN UNITS	THIRD ANGLE PROJECTION		
			$\nabla_F = 0$ $\nabla_{F_1} = 0$ $\nabla_{F_2} = 0$	mm INCH 4 PLACES ± --- ± --- 3 PLACES ± --- ± --- 2 PLACES ± 0.2 ± --- 1 PLACE ± --- ± --- ANGULAR ± 3 °	MM ONLY	NTS	METRIC	DRAWN BY: YLQ1AO DATE: 2005/03/14 CHECKED BY: PTLIM DATE: 2005/03/29 APPROVED BY: MLONG DATE: 2010/03/10	TITLE	CUSTOM HEADER 2.54MM PITCH SINGLE ROW SINGLE WAFER SMT HEADER
			DRAFT WHERE APPLICABLE MUST REMAIN WITHIN DIMENSIONS			SEE TABLE	MATERIAL NO. SD-87898-001	MOLEX INCORPORATED DOCUMENT NO.	SHEET NO.	16 OF 20
						THIS DRAWING CONTAINS INFORMATION THAT IS PROPRIETARY TO MOLEX INCORPORATED AND SHOULD NOT BE USED WITHOUT WRITTEN PERMISSION				

CKT	DIMENSION				
	Bo	Ao	Ko	F	W
2	8.02	5.20	13.60	11.50	24.00
4	10.55	5.20	11.30	11.50	24.00

EMBOSSED CARRIER TYPE 'A'

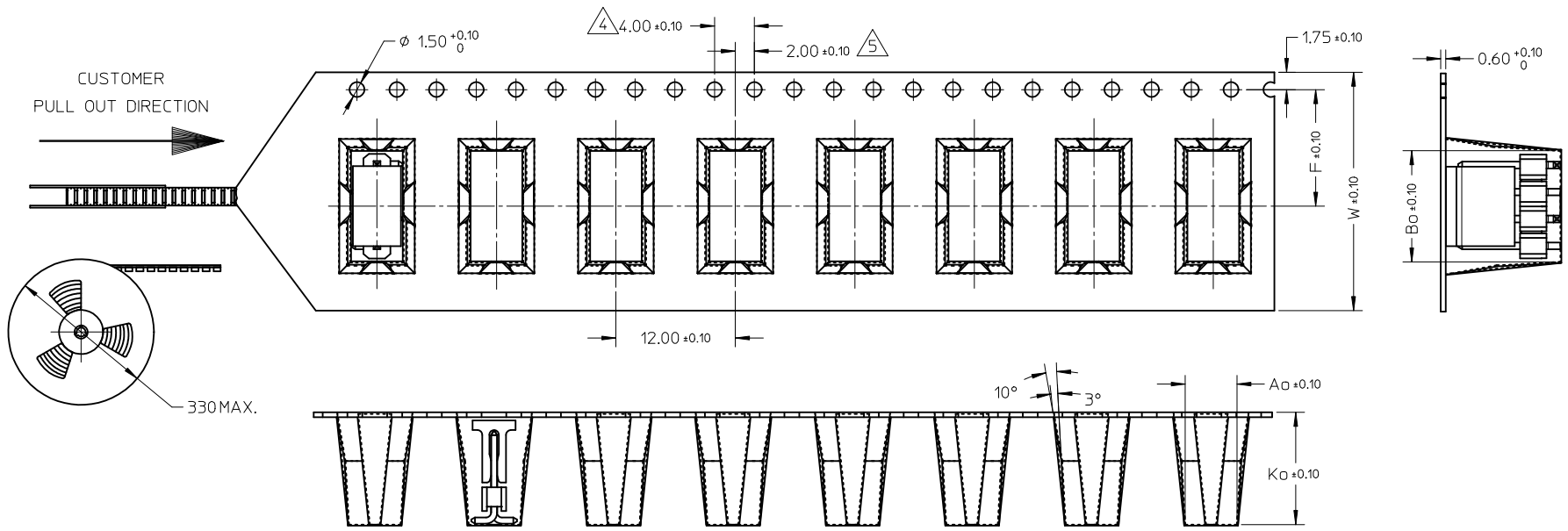

NOTES:

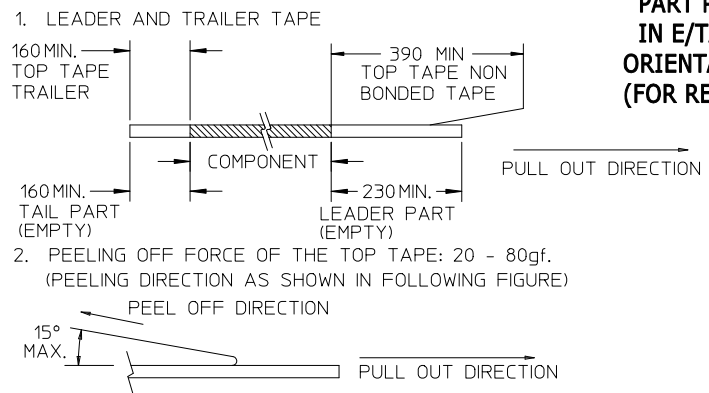

**PART PACK
IN E/TAPE
ORIENTATION
(FOR REF USE)**

- 4. MEASURED FROM CENTRELINE OF SPROCKET HOLE TO CENTRELINE OF SPOCKET
- 5. CUMULATIVE TOLERANCE OF 10 SPROCKET HOLE IS ±0.20mm
- 6. A0 AND B0 ARE MEASURED FROM ABOVE POCKET BASE 0.30mm
- 7. TAPE AND REEL SPECIFICATION IS AS PER EIA-481.
- 8. TAPE AND REEL QUANTITY : 440PCS/REEL
- 9. THE TAPE IS TREATED FOR ANTI-STATIC.
- 10. ALL RADIUS ARE 0.30MM UNLESS SPECIFY
- 11. SURFACE RESISTIVITY 10³ TO 10 OHMS.

EWR#1228, +0209 EC NO: S2010-0966 DRW:NATSEE 2010/05/20 CHK:DPTLIM 2005/03/29 APPR:MLONG 2010/06/08	QUALITY SYMBOLS $\nabla_A = 0$ $\nabla_C = 0$ $\nabla_B = 0$	GENERAL TOLERANCES (UNLESS SPECIFIED)		DIMENSION STYLE MM ONLY		SCALE NTS	DESIGN UNITS METRIC	THIRD ANGLE PROJECTION		
			mm	INCH	DRAWN BY YLQ1A0	DATE 2005/03/14	TITLE CUSTOM HEADER 2.54MM PITCH SINGLE ROW SINGLE WAFER SMT HEADER			
			4 PLACES ± --- ± ---	3 PLACES ± --- ± ---	2 PLACES ± 0.2 ± ---	1 PLACE ± --- ± ---	CHECKED BY PTLIM	DATE 2005/03/29	MOLEX INCORPORATED	
			ANGULAR ± 3 °		APPROVED BY MLONG		DATE 2010/03/10	DOCUMENT NO. SD-87898-001		
REV B3	DRAFT WHERE APPLICABLE MUST REMAIN WITHIN DIMENSIONS			MATERIAL NO. SEE TABLE	SHEET NO. 17 OF 20			SIZE A3		
THIS DRAWING CONTAINS INFORMATION THAT IS PROPRIETARY TO MOLEX INCORPORATED AND SHOULD NOT BE USED WITHOUT WRITTEN PERMISSION										

10 9 8 7 6 5 4 3 2 1

CKT	DIMENSION				
	Bo	Ao	Ko	F	W
5	13.10	5.20	11.30	11.50	24.00

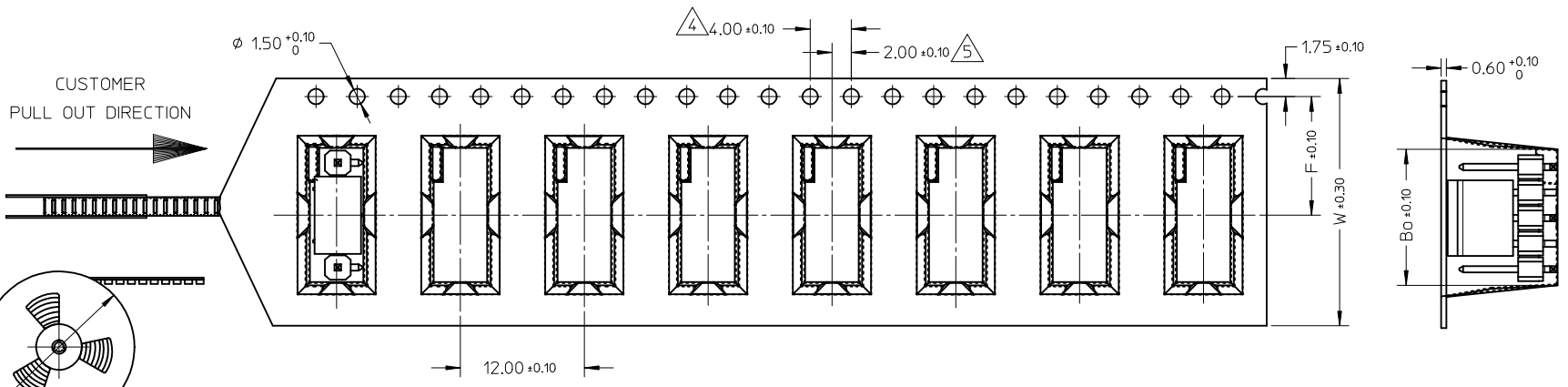

NOTES:

1. LEADER AND TRAILER TAPE

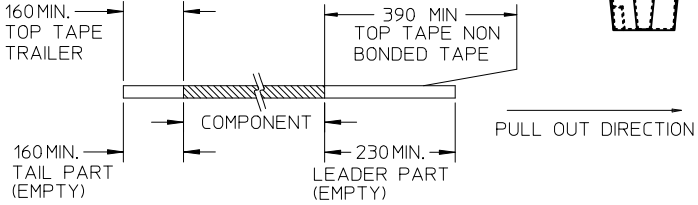

2. PEELING OFF FORCE OF THE TOP TAPE: 20 - 80gf.
(PEELING DIRECTION AS SHOWN IN FOLLOWING FIGURE)

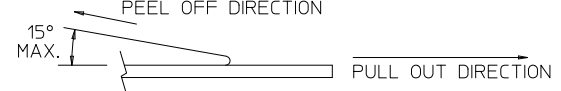

- 3. MATERIAL: BLACK P.S CONDUCTIVE, BLACK
- 4. MEASURED FROM CENTRELINE OF SPROCKET HOLE TO CENTRELINE OF SPOCKET
- 5. CUMULATIVE TOLERANCE OF 10 SPROCKET HOLE IS +0.20mm
- 6. A0 AND B0 ARE MEASURED FROM ABOVE POCKET BASE 0.30mm
- 7. TAPE AND REEL SPECIFICATION IS AS PER EIA-481.
- 8. TAPE AND REEL QUANTITY : 440PCS/REEL
- 9. THE TAPE IS TREATED FOR ANTI-STATIC.
- 10. ALL RADIUS ARE 0.30MM UNLESS SPECIFY
- 11. SURFACE RESISTIVITY 10³ TO 10 OHMS.

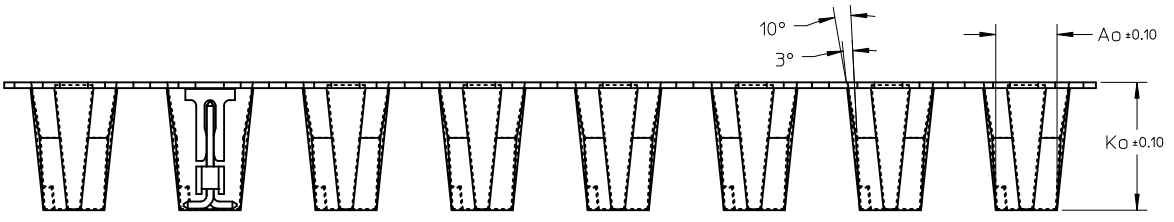

**PART PACK
IN E/TAPE
ORIENTATION
(FOR REF USE)**

EWR#1228, +0209 EC NO: S2010-0966 DRWN:ATSEE 2010/05/20 CHKD:PTLIM 2005/03/29 APPR:MLONG 2010/06/08	REV	DESCRIPTION
	B3	

QUALITY SYMBOLS	$\nabla F=0$
	$\nabla F=0$
	$\nabla F=0$

GENERAL TOLERANCES (UNLESS SPECIFIED)	mm	INCH
	4 PLACES ± ---	± ---
	3 PLACES ± ---	± ---
	2 PLACES ± 0.2	± ---
	1 PLACE ± ---	± ---
	ANGULAR ± 3 °	
DRAFT WHERE APPLICABLE MUST REMAIN WITHIN DIMENSIONS		

DIMENSION STYLE		SCALE	DESIGN UNITS	THIRD ANGLE PROJECTION
MM ONLY		NTS	METRIC	
DRAWN BY	DATE	TITLE		
YLO1A0	2005/03/14	CUSTOM HEADER		
CHECKED BY	DATE	2.54MM PITCH SINGLE ROW		
PTLIM	2005/03/29	SINGLE WAFER SMT HEADER		
APPROVED BY	DATE	MOLEX INCORPORATED		
MLONG	2010/03/10			
MATERIAL NO.	DOCUMENT NO.	SHEET NO.		
SEE TABLE	SD-87898-001	18 OF 20		

THIS DRAWING CONTAINS INFORMATION THAT IS PROPRIETARY TO MOLEX INCORPORATED AND SHOULD NOT BE USED WITHOUT WRITTEN PERMISSION	
---	--

9 8 7 6 5 4 3 2 1

10 9 8 7 6 5 4 3 2 1

CKT	DIMENSION					
	Bo	So	Ao	Ko	F	W
6	15.65	28.40	5.20	11.30	14.20	32.00
8	20.70	40.40	5.20	11.30	20.20	44.00
10	25.80	40.40	5.20	11.30	20.20	44.00
12	30.90	52.40	5.20	11.30	26.20	56.00
14	35.95	52.40	5.20	11.30	26.20	56.00
16	41.05	52.40	5.20	11.30	26.20	56.00
18	46.20	68.40	5.20	11.30	34.20	72.00
20	51.20	68.40	5.20	11.30	34.20	72.00

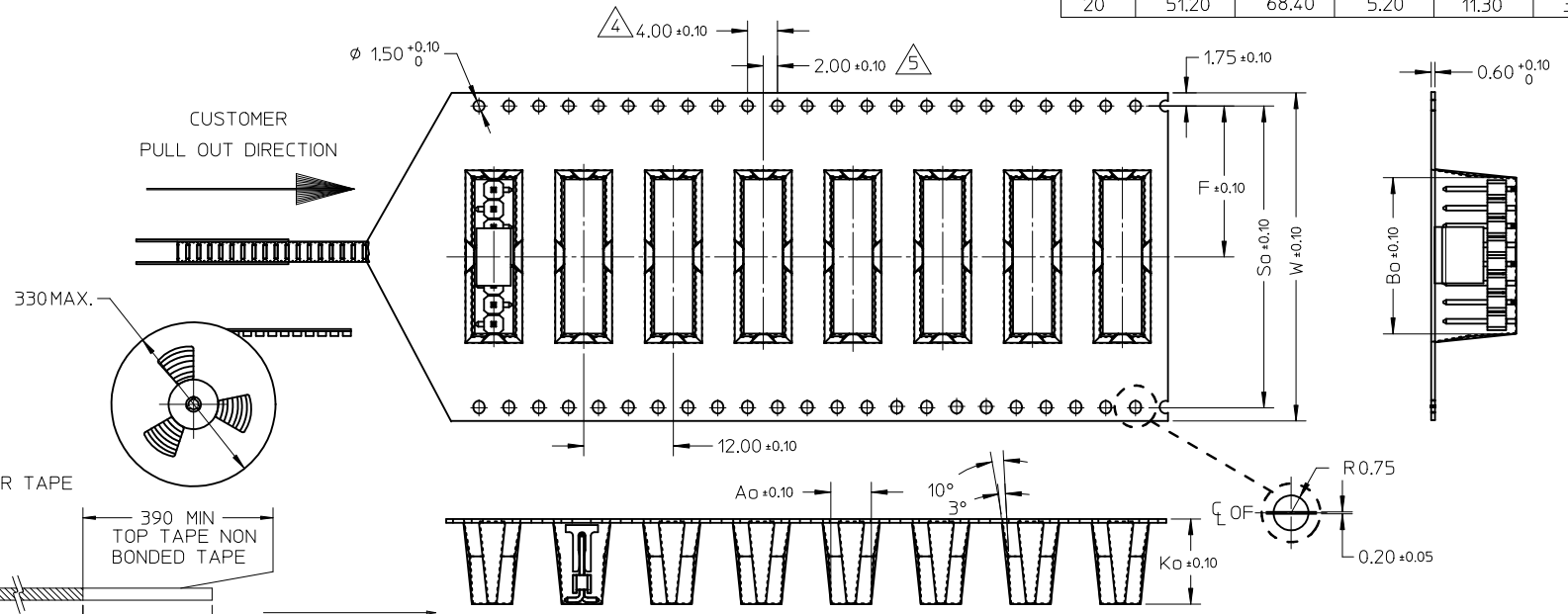

- NOTES:
- LEADER AND TRAILER TAPE
 160 MIN. TOP TAPE TRAILER
 390 MIN. TOP TAPE NON BONDED TAPE
 160 MIN. TAIL PART (EMPTY)
 230 MIN. LEADER PART (EMPTY)
 PEEL OFF DIRECTION
 15° MAX.
 - PEELING OFF FORCE OF THE TOP TAPE: 20 - 80gf.
 (PEELING DIRECTION AS SHOWN IN FOLLOWING FIGURE)
 - MATERIAL: BLACK P.S CONDUCTIVE, BLACK

**PART PACK
IN E/TAPE
ORIENTATION
(FOR REF USE)**

EWR#1228, +0209 EC NO: S2010-0966 DRWNA:SEE 2010/05/20 CHKD:PTLM 2005/03/29 APPR:MLONG 2010/06/08	QUALITY SYMBOLS $\nabla F=0$ $\nabla F=0$ $\nabla F=0$	GENERAL TOLERANCES (UNLESS SPECIFIED)		DIMENSION STYLE		SCALE	DESIGN UNITS	THIRD ANGLE PROJECTION			
				MM ONLY		NTS	METRIC				
				mm	INCH	DRAWN BY	DATE	TITLE			
						YLOQIAO	2005/03/14	CUSTOM HEADER			
B3	DESCRIPTION REV	4 PLACES ± --- ± ---		CHECKED BY		2.54MM PITCH SINGLE ROW					
		3 PLACES ± --- ± ---		DATE		SINGLE WAFER SMT HEADER					
		2 PLACES ± 0.2 ± ---		PTL IM		MOLEX INCORPORATED					
		1 PLACE ± --- ± ---		2005/03/29		MATERIAL NO. DOCUMENT NO. SHEET NO.					
		ANGULAR ± 3°		APPROVED BY		MLONG		2010/03/10			
		DRAFT WHERE APPLICABLE MUST REMAIN WITHIN DIMENSIONS		SEE TABLE		SD-87898-001		19 OF 20			
				SIZE A3		THIS DRAWING CONTAINS INFORMATION THAT IS PROPRIETARY TO MOLEX INCORPORATED AND SHOULD NOT BE USED WITHOUT WRITTEN PERMISSION					

9 8 7 6 5 4 3 2 1

10 9 8 7 6 5 4 3 2 1

CKT	DIMENSION					
	Bo	So	Ao	Ko	F	W
7	18.20	40.40	5.20	11.30	20.20	44.00
9	23.25	40.40	5.20	11.30	20.20	44.00
11	28.35	40.40	5.20	11.30	20.20	44.00
13	33.40	52.40	5.20	11.30	26.20	56.00
15	38.50	52.40	5.20	11.30	26.20	56.00
17	43.60	68.40	5.20	11.30	34.20	72.00
19	48.70	68.40	5.20	11.30	34.20	72.00
21	53.80	68.40	5.20	11.30	34.20	72.00

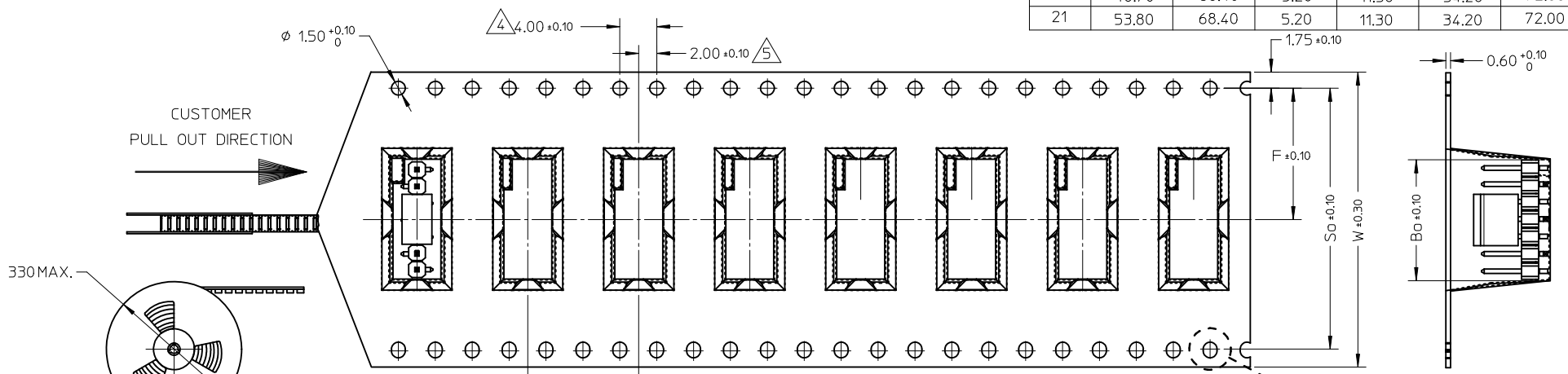

NOTES:

- LEADER AND TRAILER TAPE
 160MIN. TOP TAPE TRAILER
 160MIN. TAIL PART (EMPTY)
 390 MIN TOP TAPE NON BONDED TAPE
 230MIN. LEADER PART (EMPTY)
 PULL OUT DIRECTION
- PEELING OFF FORCE OF THE TOP TAPE: 20 - 80gf.
 (PEELING DIRECTION AS SHOWN IN FOLLOWING FIGURE)
 15° MAX.
 PEEL OFF DIRECTION
 PULL OUT DIRECTION

**PART PACK
 IN E/TAPE
 ORIENTATION
 (FOR REF USE)**

- MATERIAL: BLACK P.S CONDUCTIVE, BLACK MEASURED FROM CENTRELINE OF SPROCKET HOLE TO CENTRELINE OF SPOCKET
- CUMULATIVE TOLERANCE OF 10 SPROCKET HOLE IS ±0.20mm
- A0 AND B0 ARE MEASURE FROM ABOVE POCKET BASE 0.30mm
- TAPE AND REEL SPECIFICATION IS AS PER EIA-481.
- TAPE AND REEL QUANTITY : 440PCS/REEL
- THE TAPE IS TREATED FOR ANTI-STATIC.
- ALL RADIUS ARE 0.30MM UNLESS SPECIFY
- SURFACE RESISTIVITY 10³ TO 10 OHMS.

EWR#1228, +0209 EC NO: S2010-0966 DRW/DATE: 2010/05/20 CHKD/PTL/IM: 2005/03/29 APPR./MLONG: 2010/06/08	QUALITY SYMBOLS F=0 E=0 E=0	GENERAL TOLERANCES (UNLESS SPECIFIED)		DIMENSION STYLE		SCALE	DESIGN UNITS	THIRD ANGLE PROJECTION CUSTOM HEADER 2.54MM PITCH SINGLE ROW SINGLE WAFER SMT HEADER MOLEX INCORPORATED SD-87898-001 SHEET NO. 20 OF 20		
				MM ONLY		NTS	METRIC			
				DRAWN BY: YLQIAO		DATE: 2005/03/14			TITLE	
				CHECKED BY: PTLIM		DATE: 2005/03/29				
		APPROVED BY: MLONG		DATE: 2010/03/10						
		ANGULAR ± 3°		MATERIAL NO.		DOCUMENT NO.				
		DRAFT WHERE APPLICABLE MUST REMAIN WITHIN DIMENSIONS		SEE TABLE						
		SIZE A3		THIS DRAWING CONTAINS INFORMATION THAT IS PROPRIETARY TO MOLEX INCORPORATED AND SHOULD NOT BE USED WITHOUT WRITTEN PERMISSION						

9 8 7 6 5 4 3 2 1