

MDT0700J-RPI4MODBP-4GB KIT	1024 x 600	HDMI Interface	TFT Module
Specification			
Version: 1		Date: 12/11/2021	
Revision			
1	10/11/2021	First issue	

Display Features		
Display Size	7.0"	
Resolution	1024 x 600	
Orientation	Landscape	
Appearance	RGB	
Logic Voltage	5V	
Interface	HDMI	
Brightness	450 cd/m ²	
Touchscreen	CTP	
Module Size	192.96 x 114.76 x 26.50mm	
Operating Temperature	-20°C ~ +70°C	
Pinout	40 way pinout	
Pitch	---	Weight / Display

* - For full design functionality, please use this specification in conjunction with the TFP401 specification.(Provided Separately)

Kit Content	
Part Number	Description
MDIB-HDMI/MHDMI-RP4	Male-A To Male-B HDMI Connector
MCIC-USB	USB-to-Micro USB interconnect cable.
Raspberry Pi 4 Model B 4GB	Raspberry Pi 4 is a dual-display port desktop computer.
MDT0700JISC-HDMIC	7" Capacitive touch display with cover glass

Optional Variants	
Appearances	Voltage

Note: Responsibility of assembly lies with the customer.



Summary

TFT 7.0" is a IPS transmissive type color active matrix TFT liquid crystal display that use amorphous silicon TFT as switching devices. This module is a composed of a TFT LCD module, It is usually designed for industrial application and this module follows RoHs.

General Specification

- Size: 7.0 inch
- Dot Matrix: 1024 x RGBx600(TFT) dots
- Module dimension: 192.96(W) x 114.76(H) x 26.5MAX (D) mm
- Active area: 154.2144 x 85.92 mm
- Pixel pitch: 0.1506 x 0.1432 mm
- LCD type: TFT, Normally Black, Transmissive
- Viewing Angle: 85/85/85/85
- Aspect Ratio: 16:9
- Controller IC: TFP401 or equivalent
- Backlight Type: LED, Normally White
- TFT Interface: HDMI(only for DVI)
- CTP IC: ILI2130 or Equivalent
- CTP Interface: USB
- CTP FW Version: 0x07.0x00.0x00.0x00.0x68.0x03.0x0A.0x01
- CTP Resolution:16384*16384
- With /Without TP: With CTP
- Surface: Glare

*Color tone slight changed by temperature and driving voltage.



Pictures Of Display

Front of display



Display assembled.



Display unassembled.



Interface

1. LCM PIN Definition(CON6)

Pin	Symbol	Function	Remark
1	NC	No connection	
2	5V	Raspberry Pi:Power 5V	
3	GPIO02	Raspberry Pi:GPIO02	
4	5V	Raspberry Pi:Power 5V	
5	GPIO03	Raspberry Pi:GPIO03	
6	GND	Raspberry Pi:GND	
7	GPIO04	Raspberry Pi:GPIO04	
8	GPIO14	Raspberry Pi:GPIO14	
9	GND	Raspberry Pi:GND	
10	GPIO15	Raspberry Pi:GPIO15	
11	GPIO17	Raspberry Pi:GPIO17	
12	BL- PWM(GPIO18)	Raspberry Pi:GPIO18 (Backlight PWM)	
13	GPIO27	Raspberry Pi:GPIO27	
14	GND	Raspberry Pi:GND	
15	GPIO22	Raspberry Pi:GPIO22	
16	GPIO23	Raspberry Pi:GPIO23	
17	NC	No connection	
18	GPIO24	Raspberry Pi:GPIO24	
19	GPIO10	Raspberry Pi:GPIO10	
20	GND	Raspberry Pi:GND	
21	GPIO09	Raspberry Pi:GPIO09	
22	GPIO25	Raspberry Pi:GPIO25	
23	GPIO11	Raspberry Pi:GPIO11	
24	GPIO08	Raspberry Pi:GPIO08	
25	GND	Raspberry Pi:GND	
26	GPIO07	Raspberry Pi:GPIO07	
27	ID_SD	Raspberry Pi:ID_SD	
28	ID_SC	Raspberry Pi:ID_SC	
29	GPIO05	Raspberry Pi:GPIO05	
30	GND	Raspberry Pi:GND	
31	GPIO06	Raspberry Pi:GPIO06	



32	GPIO12	Raspberry Pi:GPIO12	
33	GPIO13	Raspberry Pi:GPIO13	
34	GND	Raspberry Pi:GND	
35	GPIO19	Raspberry Pi:GPIO19	
36	GPIO16	Raspberry Pi:GPIO16	
37	GPIO26	Raspberry Pi:GPIO26	
38	GPIO20	Raspberry Pi:GPIO20	
39	GND	Raspberry Pi:GND	
40	GPIO21	Raspberry Pi:GPIO21	

2. LCM PIN Definition (CON5)

Pin	Symbol	Function	Remark
1	3.3V	TFT Module Power limit can only output 3.3V,100mA	Note1
2	5V	Raspberry Pi:Power 5V	
3	GPIO02	Raspberry Pi:GPIO02	
4	5V	Raspberry Pi:Power 5V	
5	GPIO03	Raspberry Pi:GPIO03	
6	GND	Raspberry Pi:GND	
7	GPIO04	Raspberry Pi:GPIO04	
8	GPIO14	Raspberry Pi:GPIO14	
9	GND	Raspberry Pi:GND	
10	GPIO15	Raspberry Pi:GPIO15	
11	GPIO17	Raspberry Pi:GPIO17	
12	BL-PWM (GPIO18)	Raspberry Pi:GPIO18 (Backlight PWM)	
13	GPIO27	Raspberry Pi:GPIO27	
14	GND	Raspberry Pi:GND	
15	GPIO22	Raspberry Pi:GPIO22	
16	GPIO23	Raspberry Pi:GPIO23	
17	3.3V	TFT Module Power limit can only output 3.3V,100mA	Note1
18	GPIO24	Raspberry Pi:GPIO24	
19	GPIO10	Raspberry Pi:GPIO10	
20	GND	Raspberry Pi:GND	
21	GPIO09	Raspberry Pi:GPIO09	
22	GPIO25	Raspberry Pi:GPIO25	



23	GPIO11	Raspberry Pi:GPIO11	
24	GPIO08	Raspberry Pi:GPIO08	
25	GND	Raspberry Pi:GND	
26	GPIO07	Raspberry Pi:GPIO07	
27	ID_SD	Raspberry Pi:ID_SD	
28	ID_SC	Raspberry Pi:ID_SC	
29	GPIO05	Raspberry Pi:GPIO05	
30	GND	Raspberry Pi:GND	
31	GPIO06	Raspberry Pi:GPIO06	
32	GPIO12	Raspberry Pi:GPIO12	
33	GPIO13	Raspberry Pi:GPIO13	
34	GND	Raspberry Pi:GND	
35	GPIO19	Raspberry Pi:GPIO19	
36	GPIO16	Raspberry Pi:GPIO16	
37	GPIO26	Raspberry Pi:GPIO26	
38	GPIO20	Raspberry Pi:GPIO20	
39	GND	Raspberry Pi:GND	
40	GPIO21	Raspberry Pi:GPIO21	

Note1: The 3.3V supply current is limited; please pay special attention to use

3. USB

Pin	Symbol	Function	Remark
1	5V	Power Supply (5V)	
2	D-	Data line -	
3	D+	Data line +	
4	NC	No connection	
5	GND	Power Ground	



4. POWER JACK

Pin No.	Symbol	I/O	Function	Remark
1	5V	P	Power Supply (5V)	
2	GND	P	Ground	
3	NC		No connection	

5. DVI

Pin No.	Symbol	I/O	Function	Remark
1	Rx2+	I	+LVDS Differential Data Input	
2	GND	P	Ground	
3	Rx2-	I	-LVDS Differential Data Input	
4	Rx1+	I	+LVDS Differential Data Input	
5	GND	P	Ground	
6	Rx1-	I	-LVDS Differential Data Input	
7	Rx0+	I	+LVDS Differential Data Input	
8	GND	P	Ground	
9	Rx0-	I	-LVDS Differential Data Input	
10	RxC+	I	+LVDS Differential Clock Input	
11	GND	P	Ground	
12	RxC-	I	-LVDS Differential Clock Input	
13-14	NC	-	No connection	
15	SCL	I/O	DDC(Data Display Channel) Clock	
16	SDA	I/O	DDC(Data Display Channel) Data	
17	GND	P	Ground	
18	5V	P	Power Supply	
19	Detect	I/O	Hot plug detect	

I: input, O: output, P: Power



Contour Drawing

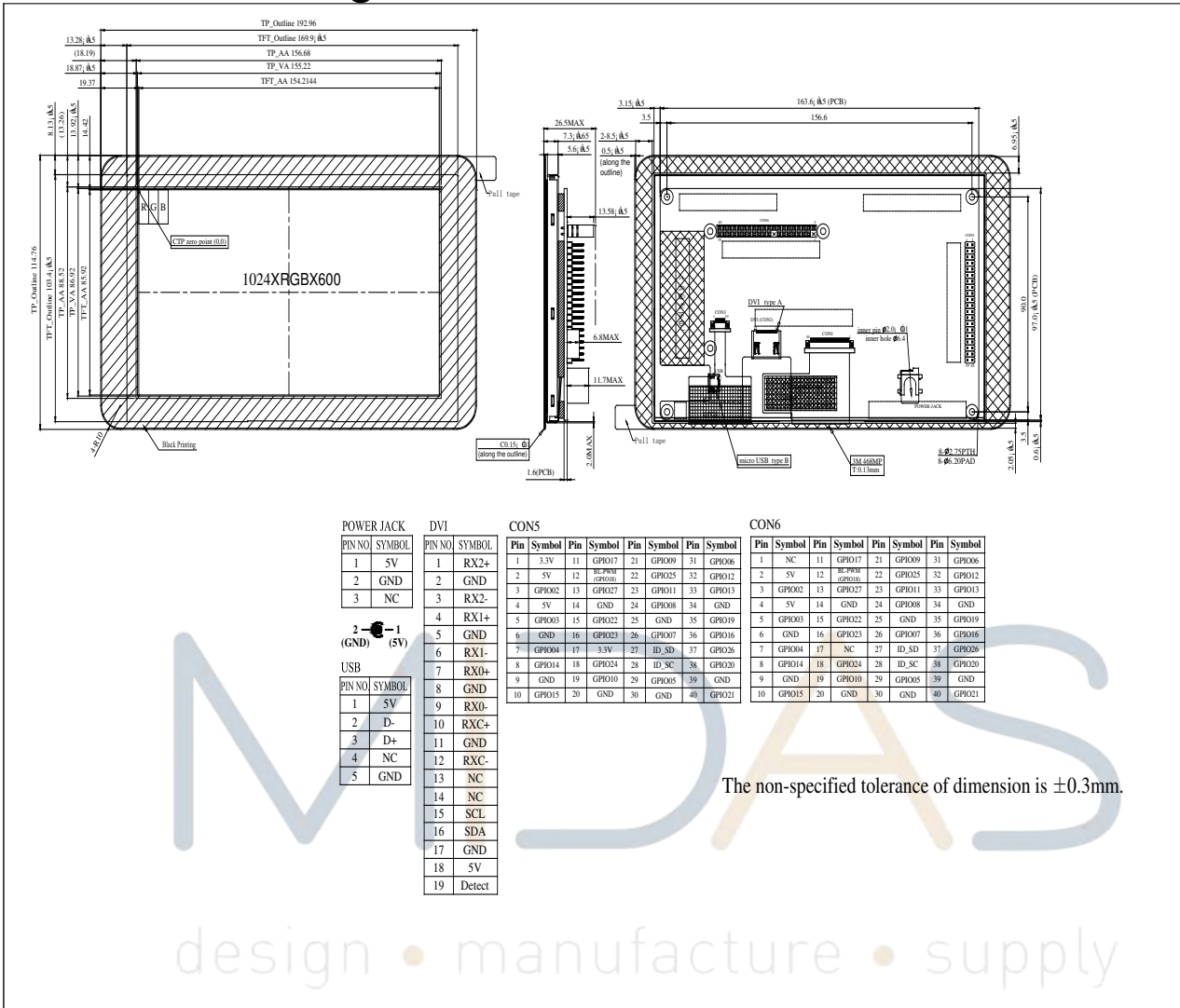

POWER JACK		DVI		CON5				CON6					
PIN NO	SYMBOL	PIN NO	SYMBOL	Pin	Symbol	Pin	Symbol	Pin	Symbol	Pin	Symbol	Pin	Symbol
1	5V	1	RX2+	1	3.3V	11	GPIO17	21	GPIO09	31	GPIO06	1	NC
2	GND	2	GND	2	5V	12	GPIO00	22	GPIO25	32	GPIO12	2	5V
3	NC	3	RX2-	3	GPIO02	13	GPIO27	23	GPIO11	33	GPIO13	3	GPIO02
		4	RX1+	4	5V	14	GND	24	GPIO08	34	GND	4	5V
		5	GND	5	GPIO03	15	GPIO22	25	GND	35	GPIO19	5	GPIO03
		6	RX1-	6	GND	16	GPIO23	26	GPIO07	36	GPIO16	6	GND
		7	RX0+	7	GPIO04	17	3.3V	27	ID_SD	37	GPIO26	7	GPIO04
		8	GND	8	GPIO14	18	GPIO24	28	ID_SC	38	GPIO20	8	GPIO14
		9	RX0-	9	GND	19	GPIO10	29	GPIO05	39	GND	9	GND
		10	RXC+	10	GPIO15	20	GND	30	GND	40	GPIO21	10	GPIO15
		11	RXC-										
		12	NC										
		13	NC										
		14	NC										
		15	SCL										
		16	SDA										
		17	GND										
		18	5V										
		19	Detect										

Absolute Maximum Ratings

Item	Symbol	Min	Typ	Max	Unit
Operating Temperature	TOP	-20	—	+70	°C
Storage Temperature	TST	-30	—	+80	°C

Note: Device is subject to be damaged permanently if stresses beyond those absolute maximum ratings listed above

- Temp. $\leq 60^\circ\text{C}$, 90% RH MAX. Temp. $> 60^\circ\text{C}$, Absolute humidity shall be less than 90% RH at 60°C

Electrical Characteristics

1. Operating conditions:

Item	Symbol	Condition	Min	Typ	Max	Unit	Remark
Supply Voltage For LCM	VDD	—	4.9	5	5.1	V	-
Supply Current For LCM	IDD	—	—	1453	2180	mA	Note 1
LED life time	—	—	—	50,000	—	Hr	Note 4

2. Backlight conditions:

Parameter	Symbol	Min.	Typ.	Max.	Unit	Remark
PWM Control Level (Backlight PWM)	High Level	-	3.3	-	V	
	Low Level	-	0	-	V	
PWM Control Frequency	-	-	1K	-	Hz	

Note 1 : This value is test for VDD =5.0V , Ta=25°C only

Note 2 : Please make sure to support enough current.

Note3 : Touch panel driver is base on the mouse driver program and through USB port connect to PC or embedded board.Can only support the single touch.

Note 4: The “LED life time” is defined as the module brightness decrease to 50% original brightness at Ta=25°C and IL =240mA. The LED lifetime could be decreased if operating IL is lager than 240mA.

Note5: The PWM control circuit is able to adjust the duty ratio linearly from 0 to 95%.



Optical Characteristics

Item	Symbol	Condition.	Min	Typ.	Max.	Unit	Remark	
Response time	Tr	$\theta=0^\circ, \Phi=0^\circ$	-	13	20	.ms	Note 3	
	Tf		-	15	25			
Contrast ratio	CR	At optimized viewing angle	600	800	-	-	Note 4	
Color Chromaticity	White	Wx	$\theta=0^\circ, \Phi=0^\circ$	0.269	0.319	0.369	-	Note 2,5,6
		Wy		0.291	0.341	0.391	-	
Viewing angle	Hor.	Θ_R	$CR \geq 10$	80	85	-	Deg.	Note 1
		Θ_L		80	85	-		
	Ver.	Φ_T		80	85	-		
		Φ_B		80	85	-		
Brightness	-	-	400	450	-	cd/m ²	Center of display	
Uniformity	(U)	-	75	-	-	%	Note 5	

Ta=25±2°C,

Note 1: Definition of viewing angle range

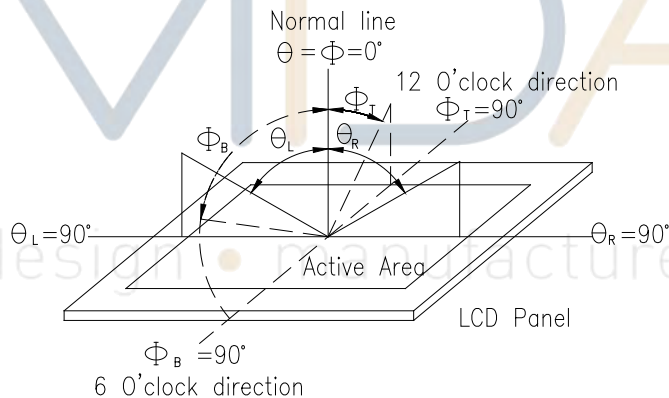

Fig. 8.1. Definition of viewing angle

Note 2: Test equipment setup:

After stabilizing and leaving the panel alone at a driven temperature for 10 minutes, the measurement should be executed. Measurement should be executed in a stable, windless, and dark room. Optical specifications are measured by Topcon BM-7orBM-5 luminance meter 1.0° field of view at a distance of 50cm and normal direction.

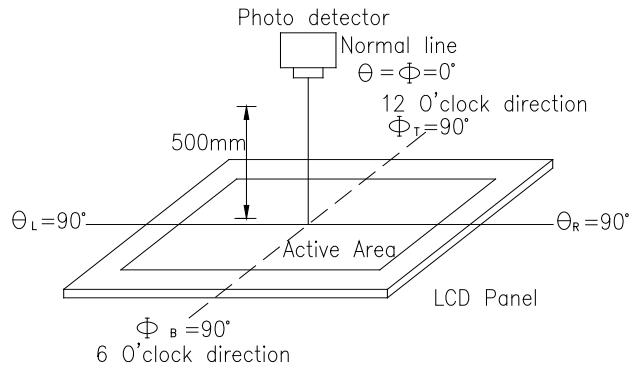
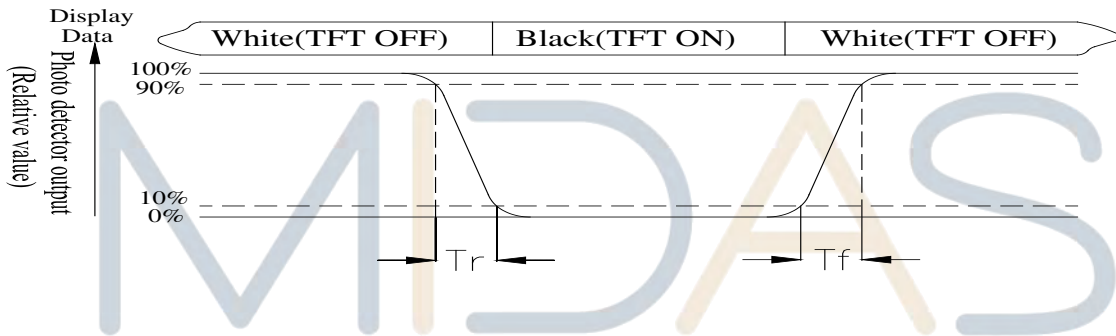

Fig. 8.2. Optical measurement system setup

Note 3: Definition of Response time:

The response time is defined as the LCD optical switching time interval between “White” state and “Black” state. Rise time, T_r , is the time between photo detector output intensity changed from 90% to 10%. And fall time, T_f , is the time between photo detector output intensity changed from 10% to 90%



Note 4: Definition of contrast ratio:

The contrast ratio is defined as the following expression.

$$\text{Contrast ratio (CR)} = \frac{\text{Luminance measured when LCD on the "White" state}}{\text{Luminance measured when LCD on the "Black" state}}$$



Note 5: Definition of Luminance Uniformity

Active area is divided into 9 measuring areas (reference the picture in below). Every measuring point is placed at the center of each measuring area.

Luminance Uniformity (U) = $L_{min}/L_{max} \times 100\%$

L = Active area length

W = Active area width

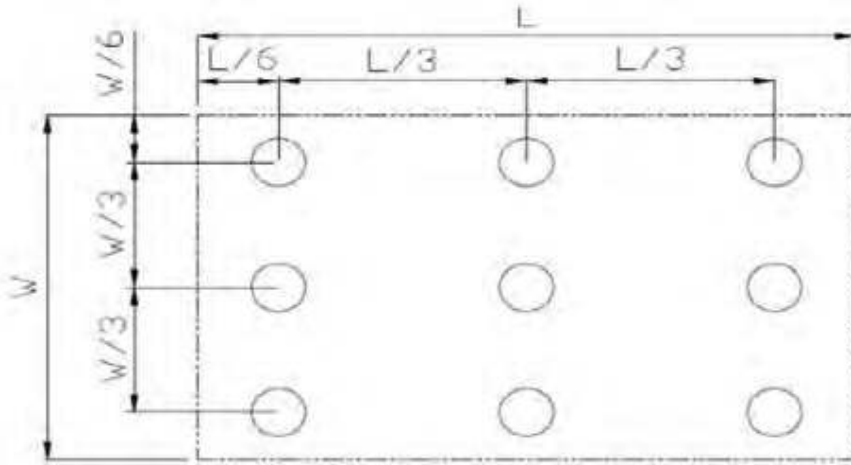

Fig 8.3. Definition of uniformity

Note 6: Definition of color chromaticity (CIE 1931)

Color coordinates measured at the center point of LCD

Note 7: Measured at the center area of the panel when all the input terminals of LCD panel are electrically opened.

design • manufacture • supply



Reliability

Content of Reliability Test (Wide temperature, -20°C~70°C)

Environmental Test			
Test Item	Content of Test	Test Condition	Note
High Temperature storage	Endurance test applying the high storage temperature for a long time.	80°C 200hrs	2
Low Temperature storage	Endurance test applying the low storage temperature for a long time.	-30°C 200hrs	1,2
High Temperature Operation	Endurance test applying the electric stress (Voltage & Current) and the thermal stress to the element for a long time.	70°C 200hrs	—
Low Temperature Operation	Endurance test applying the electric stress under low temperature for a long time.	-20°C 200hrs	1
High Temperature/ Humidity Operation	The module should be allowed to stand at 60°C,90%RH max	60°C,90%RH 96hrs	1,2
Thermal shock resistance	The sample should be allowed stand the following 10 cycles of operation <div style="text-align: center;"> <p style="margin: 0;">-20°C 25°C 70°C</p> <p style="margin: 0;">30min 5min 30min</p> <p style="margin: 0;">1 cycle</p> </div>	-20°C/70°C 10 cycles	—
Vibration test	Endurance test applying the vibration during transportation and using.	Total fixed amplitude : 1.5mm Vibration Frequency : 10~55Hz One cycle 60 seconds to 3 directions of X,Y,Z for Each 15 minutes	3
Static electricity test	Endurance test applying the electric stress to the terminal.	VS=±600V(contact) ,±800v(air), RS=330Ω CS=150pF 10 times	—

Note1: No dew condensation to be observed.

Note2: The function test shall be conducted after 4 hours storage at the normal Temperature and humidity after remove from the test chamber.

Note3: The packing have to including into the vibration testing.



Summary

The MDIB-HDMI/MHDMI-RP4 is a HDMI interconnect board With a male HDMI connector to male micro HDMI connector

Contour Drawing

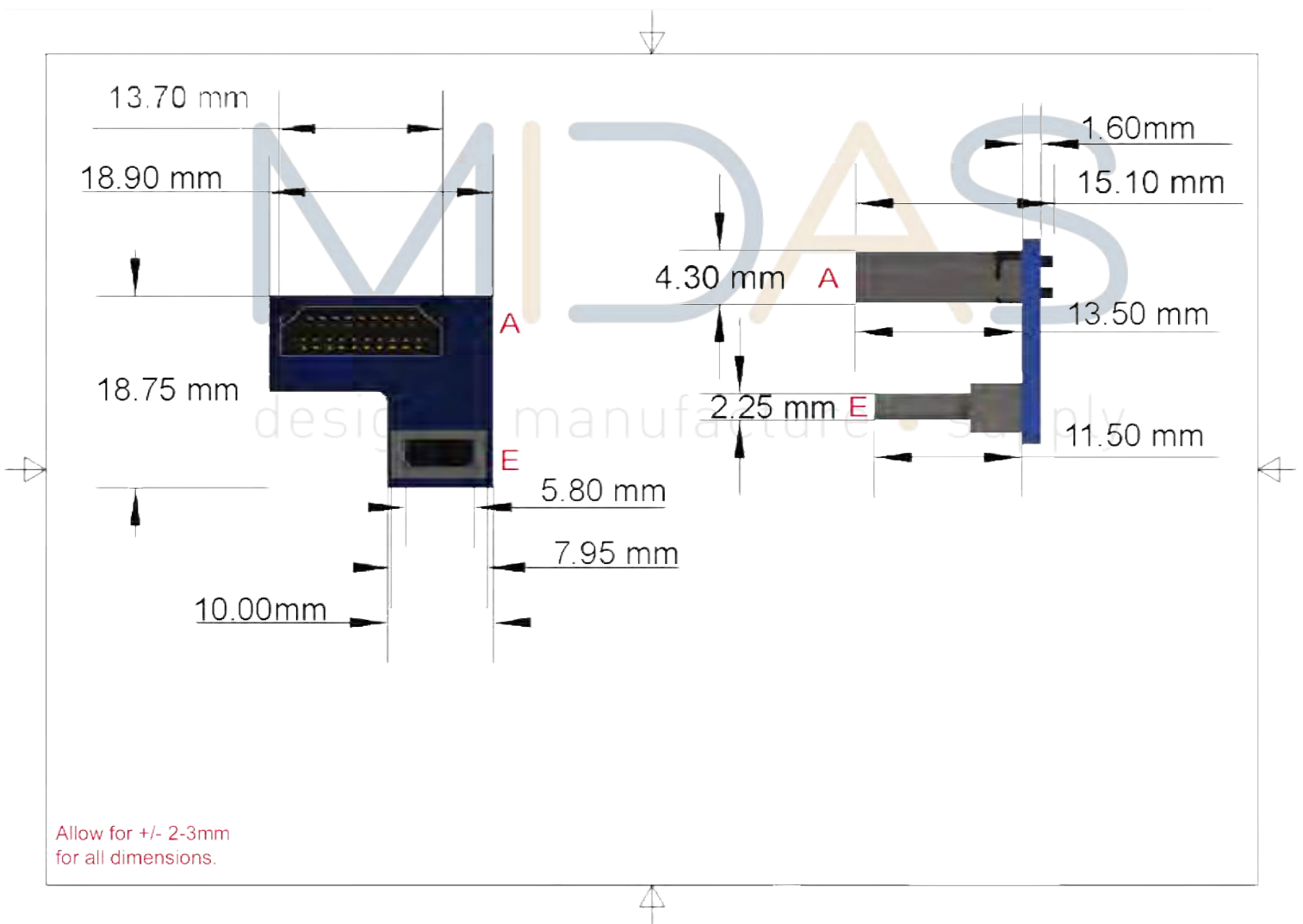

Summary

The MCIC-USB is a HDMI interconnect cable With a type-A USB connector to micro-B USB connector.

Contour Drawing

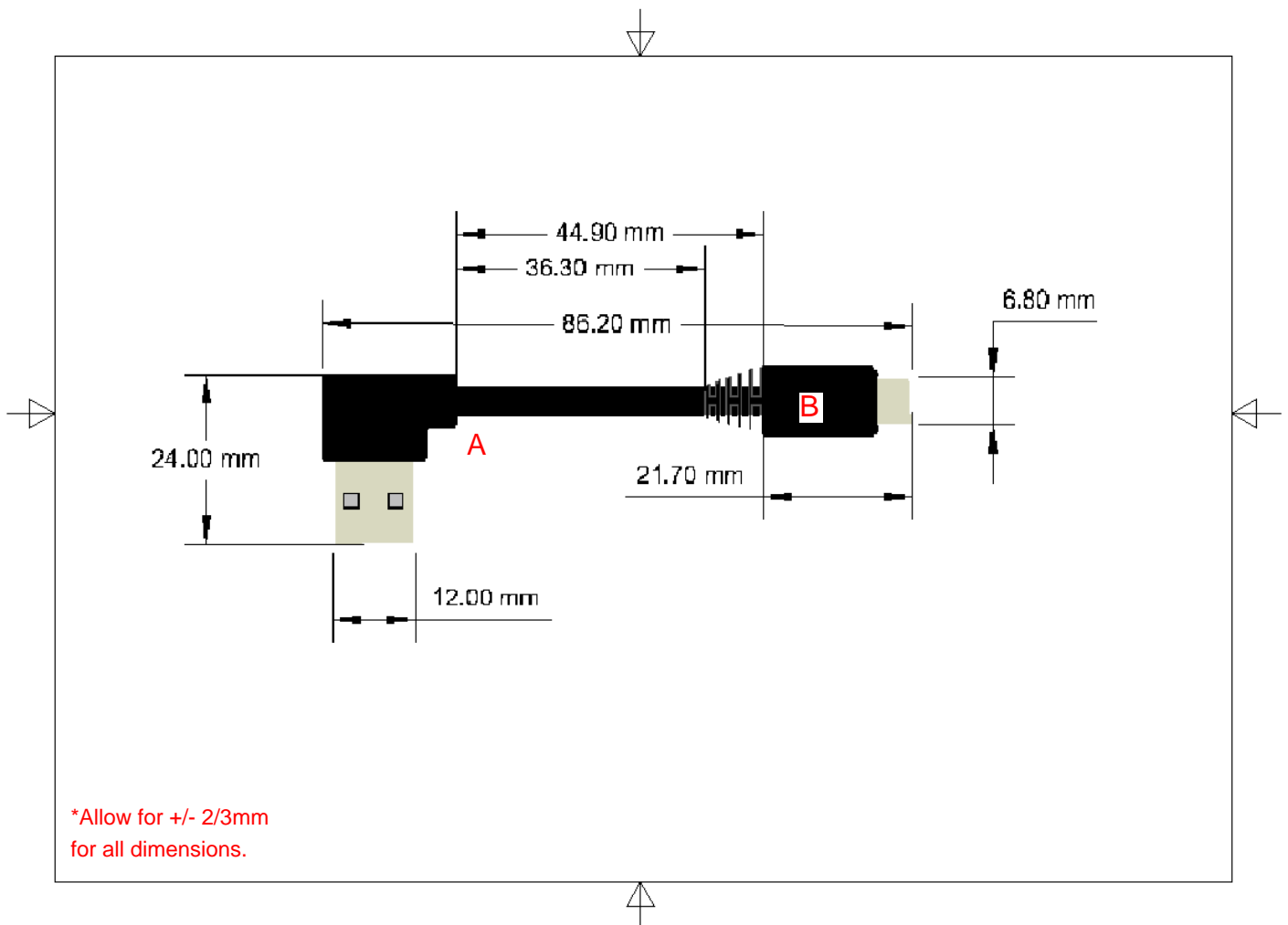

Summary

The Raspberry Pi 4 Model B (Pi4B) is the first of a new generation of Raspberry Pi computers supporting more RAM and with significantly enhanced CPU, GPU and I/O performance; all within a similar form factor, power envelope and cost as the previous generation Raspberry Pi 3B+.

The Pi4B is available with either 1, 2 and 4 Gigabytes of LPDDR4 SDRAM.

Features

1. Hardware

- Quad core 64-bit ARM-Cortex A72 running at 1.5GHz
- 1, 2 and 4 Gigabyte LPDDR4 RAM options
- H.265 (HEVC) hardware decode (up to 4Kp60)
- H.264 hardware decode (up to 1080p60)
- VideoCore VI 3D Graphics
- Supports dual HDMI display output up to 4Kp60

2. Interfaces

- 802.11 b/g/n/ac Wireless LAN
- Bluetooth 5.0 with BLE
- 1x SD Card
- 2x micro-HDMI ports supporting dual displays up to 4Kp60 resolution
- 2x USB2 ports
- 2x USB3 ports
- 1x Gigabit Ethernet port (supports PoE with add-on PoE HAT)
- 1x Raspberry Pi camera port (2-lane MIPI CSI)
- 1x Raspberry Pi display port (2-lane MIPI DSI)
- 28x user GPIO supporting various interface options:
 - Up to 6x UART
 - Up to 6x I2C
 - Up to 5x SPI
 - 1x SDIO interface
 - 1x DPI (Parallel RGB Display)
 - 1x PCM
 - Up to 2x PWM channels
 - Up to 3x GPCLK outputs



3. Software

- ARMv8 Instruction Set
- Mature Linux software stack
- Actively developed and maintained
 - Recent Linux kernel support
 - Many drivers upstreamed
 - Stable and well supported userland
 - Availability of GPU functions using standard APIs

Mechanical Specification

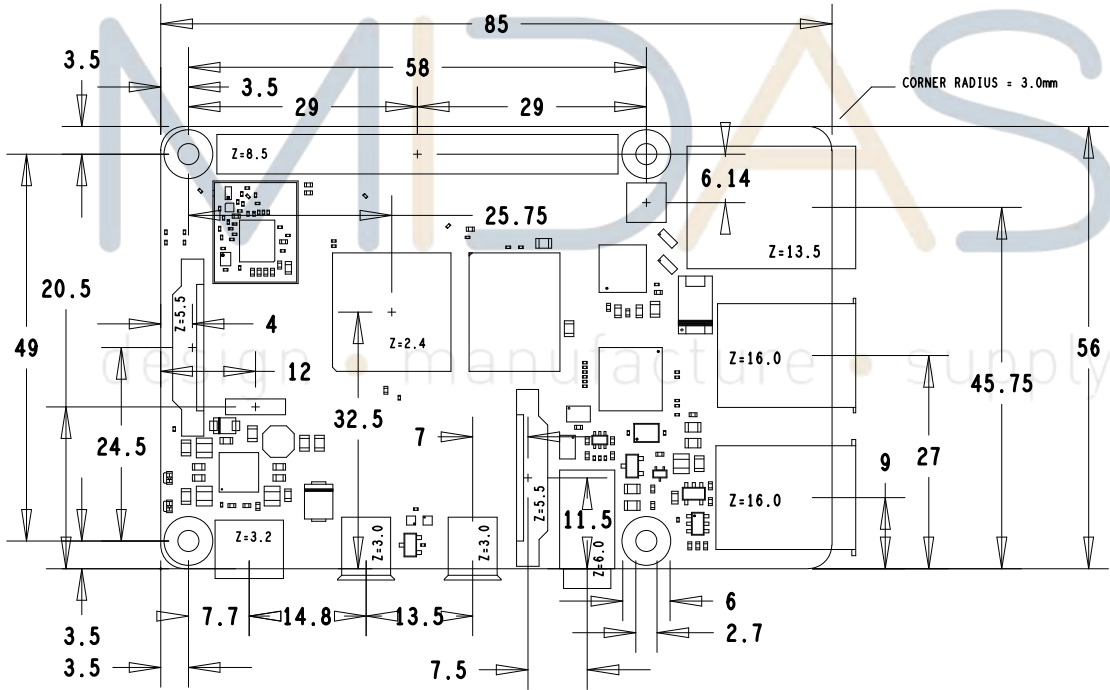

Figure 1: Mechanical Dimensions

Electrical Specification

Caution! Stresses above those listed in Table 2 may cause permanent damage to the device. This is a stress rating only; functional operation of the device under these or any other conditions above those listed in the operational sections of this specification is not implied. Exposure to absolute maximum rating conditions for extended periods may affect device reliability.



Symbol	Parameter	Minimum	Maximum	Unit
V _{IN}	5V Input Voltage	-0.5	6.0	V

Table 2: Absolute Maximum Ratings

Please note that VDD IO is the GPIO bank voltage which is tied to the on-board
- 3.3V supply rail.

Symbol	Parameter	Conditions	Minimum	Typical	Maximum	Unit
V _{IL}	Input low voltage ^a	VDD IO = 3.3V	-	-	TBD	V
V _{IH}	Input high voltage ^a	VDD IO = 3.3V	TBD	-	-	V
I _{IL}	Input leakage current	TA = +85°C	-	-	TBD	µA
C _{IN}	Input capacitance	-	-	TBD	-	pF
V _{OL}	Output low voltage ^b	VDD IO = 3.3V, IOL = -2mA	-	-	TBD	V
V _{OH}	Output high voltage ^b	VDD IO = 3.3V, IOH = 2mA	TBD	-	-	V
I _{OL}	Output low current ^c	VDD IO = 3.3V, VO = 0.4V	TBD	-	-	mA
I _{OH}	Output high current ^c	VDD IO = 3.3V, VO = 2.3V	TBD	-	-	mA
R _{PU}	Pullup resistor	-	TBD	-	TBD	kΩ
R _{PD}	Pulldown resistor	-	TBD	-	TBD	kΩ

^a Hysteresis enabled

^b Default drive strength (8mA)

^c Maximum drive strength (16mA)

Table 3: DC Characteristics

Pin Name	Symbol	Parameter	Minimum	Typical	Maximum	Unit
Digital outputs	t _{rise}	10-90% rise time ^a	-	TBD	-	ns
Digital outputs	t _{fall}	90-10% fall time ^a	-	TBD	-	ns

^a Default drive strength, CL = 5pF, VDD IO = 3.3V

Table 4: Digital I/O Pin AC Characteristics

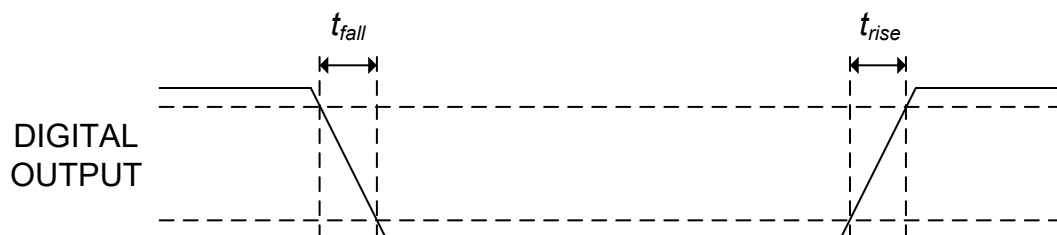

Figure 2: Digital IO Characteristics

1. Power Requirements

The Pi4B requires a good quality USB-C power supply capable of delivering 5V at 3A. If attached downstream USB devices consume less than 500mA, a 5V, 2.5A supply may be used.

Peripherals

1. GPIO Interface

The Pi4B makes 28 BCM2711 GPIOs available via a standard Raspberry Pi 40-pin header. This header is backwards compatible with all previous Raspberry Pi boards with a 40-way header.

1.1 GPIO Pin Assignments

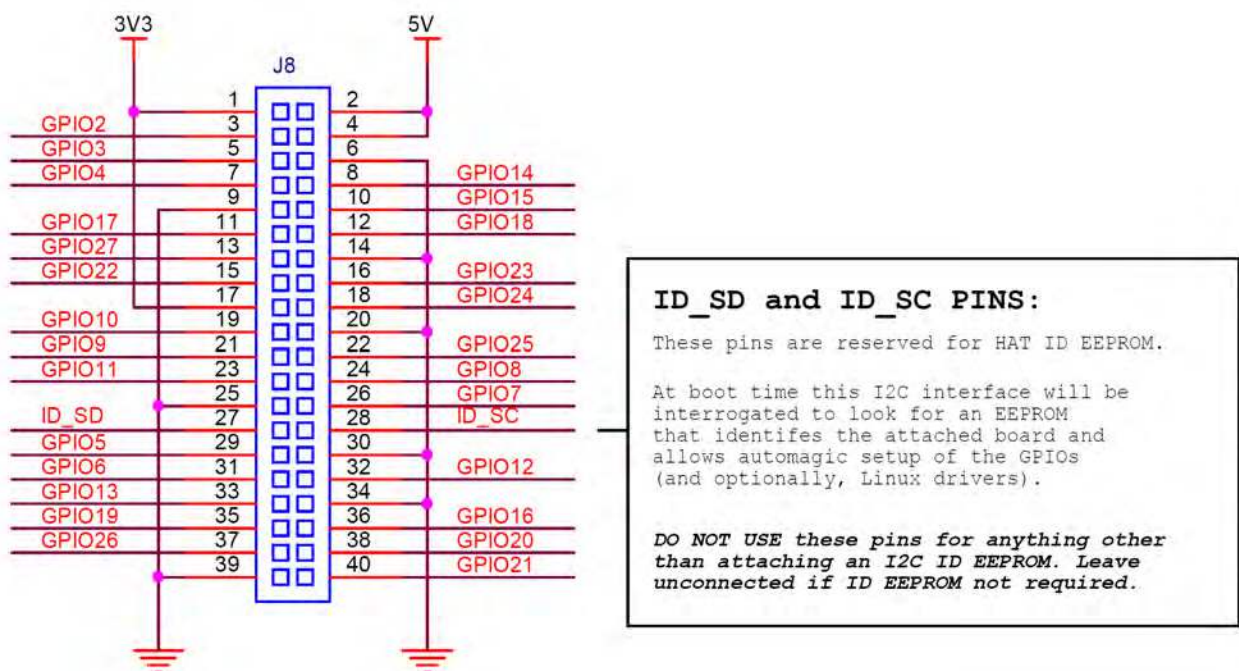

Figure 3: GPIO Connector Pinout

As well as being able to be used as straightforward software controlled input and output (with programmable pulls), GPIO pins can be switched (multiplexed) into various other modes backed by dedicated peripheral blocks such as I2C, UART and SPI.

In addition to the standard peripheral options found on legacy Pis, extra I2C, UART and SPI peripherals have been added to the BCM2711 chip and are available as further mux options on the Pi4. This gives users much more flexibility when attaching add-on hardware as compared to older models.

1.2 GPIO Alternate Functions

GPIO	Default Pull	ALT0	ALT1	ALT2	ALT3	ALT4	ALT5
0	High	SDA0	SA5	PCLK	SPI3.CE0.N	TXD2	SDA6
1	High	SCL0	SA4	DE	SPI3.MISO	RXD2	SCL6
2	High	SDA1	SA3	LCD.VSYNC	SPI3.MOSI	CTS2	SDA3
3	High	SCL1	SA2	LCD.HSYNC	SPI3.SCLK	RTS2	SCL3
4	High	GPCLK0	SA1	DPI.D0	SPI4.CE0.N	TXD3	SDA3
5	High	GPCLK1	SA0	DPI.D1	SPI4.MISO	RXD3	SCL3
6	High	GPCLK2	SOE.N	DPI.D2	SPI4.MOSI	CTS3	SDA4
7	High	SPI0.CE1.N	SWE.N	DPI.D3	SPI4.SCLK	RTS3	SCL4
8	High	SPI0.CE0.N	SD0	DPI.D4	- TXD4		SDA4
9	Low	SPI0.MISO	SD1	DPI.D5	- RXD4		SCL4
10	Low	SPI0.MOSI	SD2	DPI.D6	- CTS4		SDA5
11	Low	SPI0.SCLK	SD3	DPI.D7	- RTS4		SCL5
12	Low	PWM0	SD4	DPI.D8	SPI5.CE0.N	TXD5	SDA5
13	Low	PWM1	SD5	DPI.D9	SPI5.MISO	RXD5	SCL5
14	Low	TXD0	SD6	DPI.D10	SPI5.MOSI	CTS5	TXD1
15	Low	RXD0	SD7	DPI.D11	SPI5.SCLK	RTS5	RXD1
16	Low	FL0	SD8	DPI.D12	CTS0	SPI1.CE2.N	CTS1
17	Low	FL1	SD9	DPI.D13	RTS0	SPI1.CE1.N	RTS1
18	Low	PCM.CLK	SD10	DPI.D14	SPI6.CE0.N	SPI1.CE0.N	PWM0
19	Low	PCM.FS	SD11	DPI.D15	SPI6.MISO	SPI1.MISO	PWM1
20	Low	PCM.DIN	SD12	DPI.D16	SPI6.MOSI	SPI1.MOSI	GPCLK0
21	Low	PCM.DOUT	SD13	DPI.D17	SPI6.SCLK	SPI1.SCLK	GPCLK1
22	Low	SD0.CLK	SD14	DPI.D18	SD1.CLK	ARM.TRST	SDA6
23	Low	SD0.CMD	SD15	DPI.D19	SD1.CMD	ARM.RTCK	SCL6
24	Low	SD0.DAT0	SD16	DPI.D20	SD1.DAT0	ARM.TDO	SPI3.CE1.N
25	Low	SD0.DAT1	SD17	DPI.D21	SD1.DAT1	ARM.TCK	SPI4.CE1.N
26	Low	SD0.DAT2	TE0	DPI.D22	SD1.DAT2	ARM.TDI	SPI5.CE1.N
27	Low	SD0.DAT3	TE1	DPI.D23	SD1.DAT3	ARM.TMS	SPI6.CE1.N

Table 5: Raspberry Pi 4 GPIO Alternate Functions

Table 5 details the default pin pull state and available alternate GPIO functions. Most of these alternate peripheral functions are described in detail in the BCM2711 Peripherals Specification document which can be downloaded from the hardware documentation section of the website.



1.3 Display Parallel Interface (DPI)

A standard parallel RGB (DPI) interface is available the GPIOs. This up-to-24-bit parallel interface can support a secondary display.

1.4 SD/SDIO Interface

The Pi4B has a dedicated SD card socket which supports 1.8V, DDR50 mode (at a peak bandwidth of 50 Megabytes / sec). In addition, a legacy SDIO interface is available on the GPIO pins.

2. Camera and Display Interfaces

The Pi4B has 1x Raspberry Pi 2-lane MIPI CSI Camera and 1x Raspberry Pi 2-lane MIPI DSI Display connector. These connectors are backwards compatible with legacy Raspberry Pi boards, and support all of the available Raspberry Pi camera and display peripherals.

3. USB

The Pi4B has 2x USB2 and 2x USB3 type-A sockets. Downstream USB current is limited to approximately 1.1A in aggregate over the four sockets.

4. HDMI

The Pi4B has 2x micro-HDMI ports, both of which support CEC and HDMI 2.0 with resolutions up to 4Kp60.

5. Audio and Composite (TV Out)

The Pi4B supports near-CD-quality analogue audio output and composite TV-output via a 4-ring TRS 'A/V' jack.

The analog audio output can drive 32 Ohm headphones directly.

6. Temperature Range and Thermals

The recommended ambient operating temperature range is 0 to 50 degrees Celcius. To reduce thermal output when idling or under light load, the Pi4B reduces the CPU clock speed and voltage. During heavier load the speed and voltage (and hence thermal output) are increased. The internal governor will throttle back both the CPU speed and voltage to make sure the CPU temperature never exceeds 85 degrees C.

The Pi4B will operate perfectly well without any extra cooling and is designed for sprint performance -expecting a light use case on average and ramping up the CPU speed when needed (e.g. when loading a webpage). If a user wishes to load the system continually or operate it at a high temperature at full performance, further cooling may be needed.

