

6

5

4

3

2

1

E

E

D

D

C

C

B

B

A

A

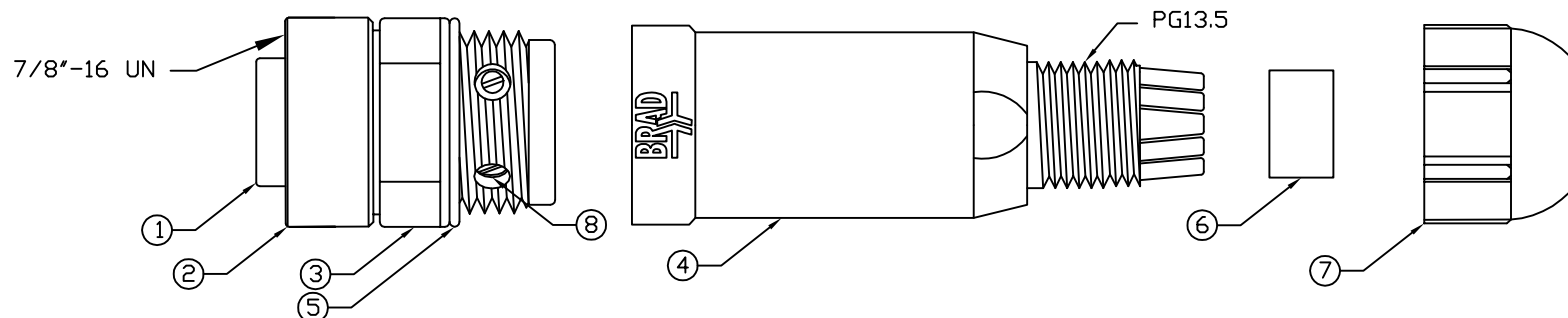

NOTES:

MATERIALS:

MOLDED BODY: BLACK POLYAMIDE
 COUPLING NUT: STAINLESS STEEL OR NI PLATED BRASS
 COMPRESSION NUT: BLACK POLYAMIDE
 GROMMET: NITRILE RUBBER
 CONTACTS: GOLD/NICKEL OVER COPPER ALLOY
 INSERT: BLACK PVC
 INSERT HOUSING: BLACK POLYAMIDE
 SET SCREWS: NI PLATED BRASS

ELECTRICAL:

CURRENT RATING: 8AMP MAX
 VOLTAGE RATING: 300V

MECHANICAL:

TEMPERATURE RANGE: -20° TO 80°C
 INGRESS PROTECTION: IP 67

AGENCY CERTIFICATIONS:

AGENCY: CSA PENDING

TABLE 1 - PART NUMBER REFERENCE

MATERIAL NUMBER	ENGINEERING NUMBER	COULPER STYLE
1300440001	1A4000-34FF8	HEX - 316 STAINLESS STEEL
1300440009	1A4000-34FF	KNURLED - NI PLATED BRASS

TABLE 2 - COMPONENT INFORMATION

ITEM	QTY	DESCRIPTION
1	1	INSULATOR
2	1	COUPLNG NUT
3	1	INSERT BODY
4	1	CONNECTOR BODY
5	1	O-RING
6	1	GROMMET
7	1	COMPRESSION NUT
8	4	SCREW, M3 x 5

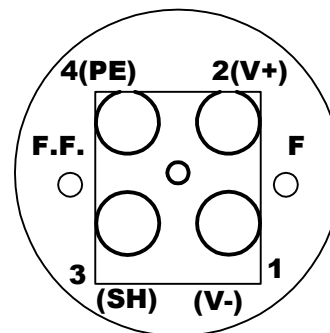

FEMALE INSERT-BACK VIEW

UPDATE PER JM EC NO: WNA2009-0313 DRWN: LHARTMAN 2008/10/27 CHKD: YOU 2008/11/07 APPR: JFMURPHY 2008/11/10	QUALITY SYMBOLS ▽=0 ▽C=0	GENERAL TOLERANCES (UNLESS SPECIFIED)		DIMENSION STYLE		SCALE	DESIGN UNITS	THIRD ANGLE PROJECTION	
			mm	INCH	----		1:1		INCH
		4 PLACES	±---	±---	DRAWN BY DATE		TITLE MINI-CHANGE FIELD ATTACH 4 POLE FEMALE ST FF PG13.5 FITTING SCREW		
		3 PLACES	±---	±.005	LHARTMAN 2008/10/27 CHECKED BY DATE YOU 2008/10/27				
2 PLACES	±---	±.010	APPROVED BY DATE		MOLEX INCORPORATED				
1 PLACE	±---	±.020	JFMURPHY 2008/10/27 MATERIAL NO.				DOCUMENT NO.	SHEET NO.	
ANGULAR ±1°			DRAFT WHERE APPLICABLE MUST REMAIN WITHIN DIMENSIONS		SEE TABLE		SD-130044-001	1 OF 1	
THIS DRAWING CONTAINS INFORMATION THAT IS PROPRIETARY TO MOLEX INCORPORATED AND SHOULD NOT BE USED WITHOUT WRITTEN PERMISSION									

6

5

4

3

2

1