

THIS DRAWING IS UNPUBLISHED.

RELEASED FOR PUBLICATION

© COPYRIGHT 2002

ALL RIGHTS RESERVED.

LOC IR DIST -

REVISIONS

P	LTR	DESCRIPTION	DATE	DWN	APVD
	A1	Text hinzu	29JUL2003	Ba.	PL.
	A2	RELEASED TO GENERAL SALES	18JUL2011	PKS	RRP
	A3	COPPER WIRE RANGE UPDATED	08MAR2018	SV	PKS

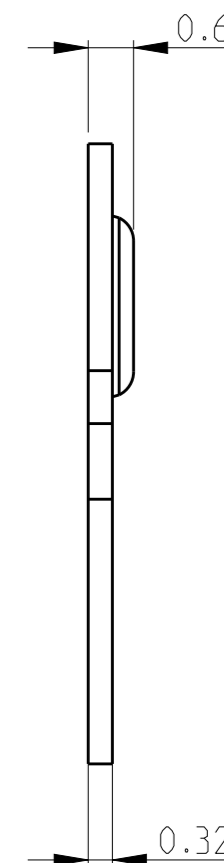
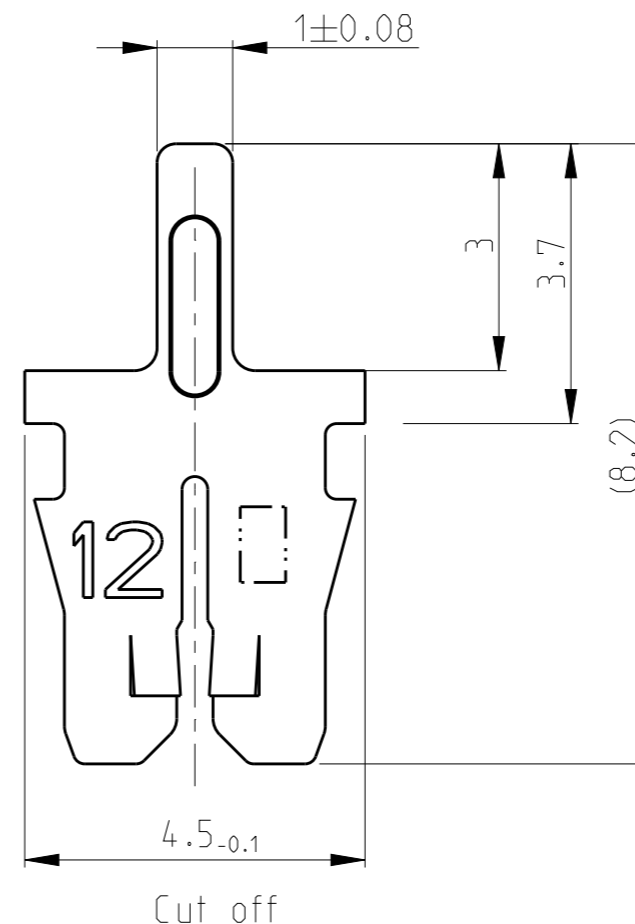
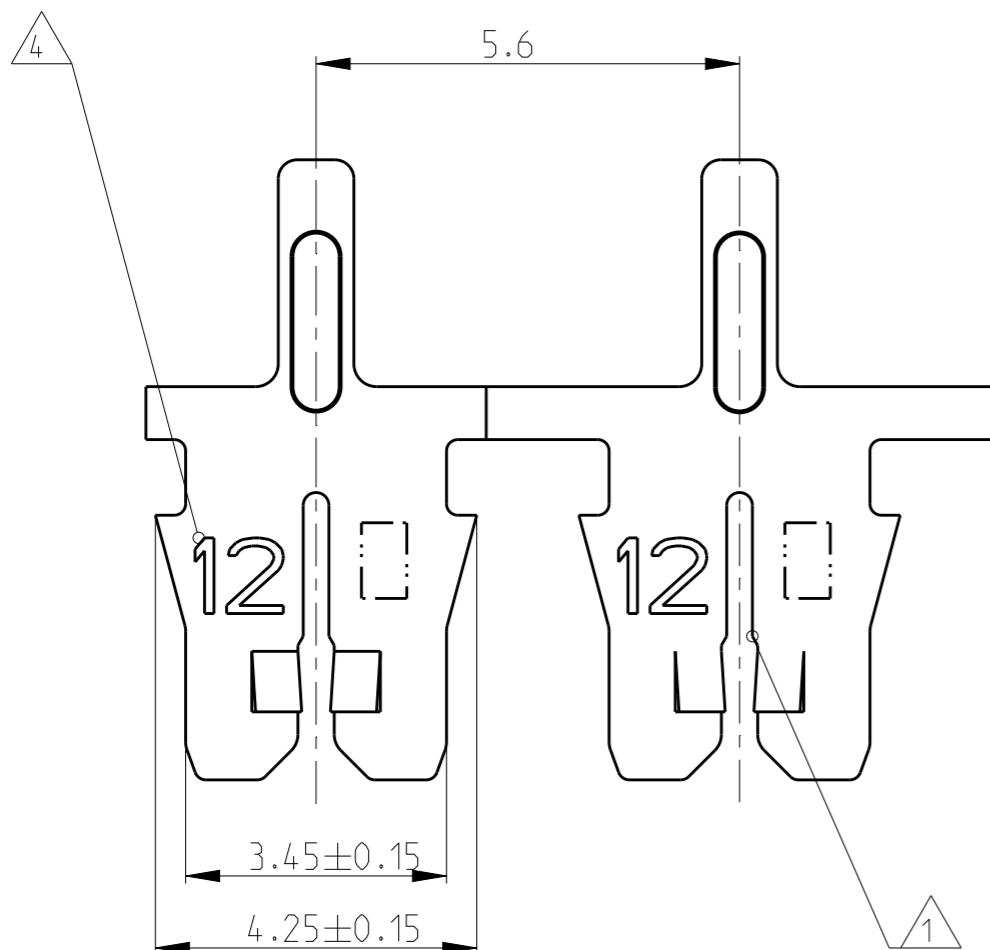

THIS DRAWING IS A CONTROLLED DOCUMENT.

DWN M. Neitzel 08JAN2002

DIMENSIONS: mm

TOLERANCES UNLESS OTHERWISE SPECIFIED:

- 0 PLC ±0.2
- 1 PLC ±0.2
- 2 PLC ±0.2
- 3 PLC ±0.2
- 4 PLC ±0.2
- ANGLES ±1°

MATERIAL SEE TABLE

FINISH SEE TABLE

CHK H. Ploesser

APVD -

PRODUCT SPEC -

APPLICATION SPEC -

WEIGHT -

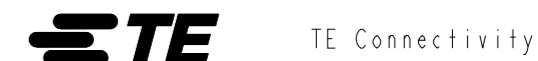

NAME MAG-MATE Kontakt mit Loetpin Baugroesse .300 mod.

SIZE A3 CAGE CODE 00779 DRAWING NO. C-1534686 RESTRICTED TO

CUSTOMER DRAWING SCALE 10:1 SHEET 1 OF 2 REV A3

4

3

2

1

THIS DRAWING IS UNPUBLISHED.

RELEASED FOR PUBLICATION

© COPYRIGHT 2002

ALL RIGHTS RESERVED.

LOC	DIST	REVISIONS			
P	LTR	DESCRIPTION	DATE	DWN	APVD
	-	SEE SHEET 1	-	-	-

DIRECTION OFF TOP OF REEL

Bemerkungen:
NOTES:

1 Geeignet fuer Kupferlackdraht
Einzel- $\varnothing 0.45 \dots 0.63 \text{mm}$ oder Doppeldraht $\varnothing 0.45 \dots 0.56 \text{mm}$
SLOT ACCEPTS:
COPPER SINGLE MAGNET WIRE $\varnothing 0.45 \dots 0.63 \text{mm}$ DIA
OR COPPER DOUBLE MAGNET WIRE $\varnothing 0.45 \dots 0.56 \text{mm}$ DIA

2 Anlieferungszustand: Kontakte fortlaufend mit
Papierzwiseilage auf Kunststoffspule aufgewickelt
Max. 5 Splice Stellen pro Spule
Splice Stellen nicht miteinander verbunden
DELIVERY STATE: CONTACTS CONTINUOUS REELED WITH
PAPER INTERLAYER ON PLASTIC-REEL.
MAX. 5 SPLICES PER REEL
SPLICES BE NOT BONDED TOGETHER.

3 Kontaktkammer nach Zeichnung } 411-18516
CAVITY ACCORDING DWG.

4 Kennziffer fuer Drahtgroessenbereich (12)
IDENTIFICATION NO. FOR MAGNET WIRE RANGE (12)

5 Materialdicke } 0.32 ± 0.02
STOCK THICKNESS

	10	A	CuNiSi	Ag OVER Ni	1-1534686-8
	10	A	CuNiSi	Au OVER Ni	1-1534686-7
	10	A	CuNiSi	BLANK	1-1534686-2
	10	A	CuSn	PRETINNED	1-1534686-1
OBSOLETE	9	B	CuNiSi	Ag OVER Ni	1534686-8
	9	B	CuNiSi	Au OVER Ni	1534686-7
	9	B	CuNiSi	BLANK	1534686-2
	9	B	CuSn	PRETINNED	1534686-1
REELING	REV.	5	MATERIAL	SURFACE COLOR	TE PART NO

THIS DRAWING IS A CONTROLLED DOCUMENT.		DWN	08JAN2002		
DIMENSIONS: mm		CHK	M. Neitzel		
TOLERANCES UNLESS OTHERWISE SPECIFIED:		APVD	H. Ploesser		
		PRODUCT SPEC	-		
MATERIAL SEE TABLE		FINISH	SEE TABLE		NAME
		WEIGHT	-		MAG-MATE Kontakt mit Loetpin Baugroesse .300 mod.
		CUSTOMER DRAWING	SCALE	10:1	SHEET 2 OF 2
			SIZE	A3	CAGE CODE
			DRAWING NO	00779	RESTRICTED TO
				©=1534686	REV
					A3

1470-19 (3/11)