

SS345PT/SS445P

Unipolar Hall-Effect Digital Position Sensors with Built-in Pull-up Resistor

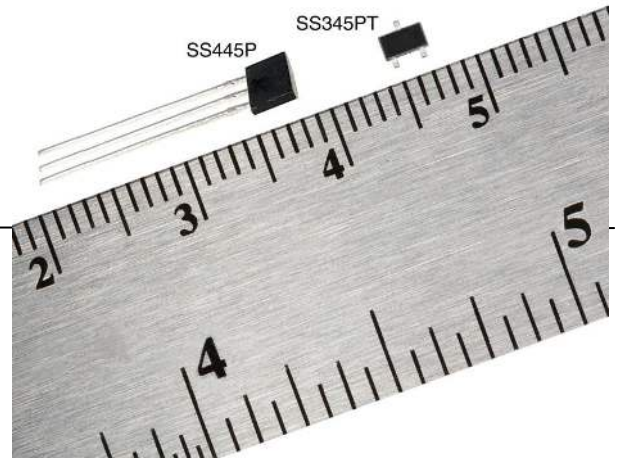

DESCRIPTION

The SS345PT/SS445P sensors are small, versatile digital Hall-effect devices that are operated by the magnetic field from a permanent magnet or an electromagnet, designed to respond to a single North pole (SS345PT) or South pole (SS445P).

These unipolar sensors are designed to meet the requirements of a wide range of potential applications. The internal pull-up resistor often eliminates the need for external components, further helping to reduce the system cost. These economical unipolar sensors are well suited for simple, high-volume, cost-sensitive position and motion sensing applications.

FEATURES

- Subminiature package size (SS345PT) uses less space on the PCB than standard Hall-effect sensor packages such as TO-92 or SOT-89, allowing for use in smaller assemblies
- Tape and reel packaging (SS345PT) allows for automated component placement, helping to reduce manufacturing costs
- Small, flat TO-92-style package (SS445P) is also available
- Simple activation from a North pole (SS345PT) or a South pole (SS445P) makes these products suitable in a variety of potential applications such as motion control, lid closure detection, and displacement sensing
- Built-in pull-up resistor can easily interface with common electronic circuits without adding external components, helping to reduce total system cost
- RoHS-compliant materials meet Directive 2002/95/EC

The 2.7 Vdc to 7 Vdc supply voltage range allows this device to be used in low voltage applications. The SS345PT's very small size requires less PCB (printed circuit board) space, allowing it to be used in smaller assemblies.

These sensors are available in two package styles: the SS345PT in the subminiature SOT-23 surface mount package; the SS445P is available in the leaded, flat TO-92-style package.

The SS345PT is available on tape and reel (3000 units per reel); the SS445P is available in a bulk package (1000 units per bag).

POTENTIAL APPLICATIONS

Commercial:

- Door or lid closure detection in appliances
- Speed and RPM sensing in fitness equipment
- Flow rate sensing in appliances and water softeners
- Damper or valve position control in HVAC equipment
- Printer head position sensing

Industrial

- Flow rate sensing in industrial processes
- Robotic control (cylinder position monitoring)
- Float-based fluid level sensing

Medical

- Displacement sensor in hospital beds and medical equipment
- Medication bin monitor on portable drug carts

SS345PT/SS445P

Table 1. SS345PT/SS445P Specifications (At 2.7 to 7 Vdc supply, 4 mA load, T_A = -40 °C to 150 °C [-40 °F to 302 °F])

Characteristic	Condition	Minimum	Typical	Maximum	Unit
Supply voltage	-40 °C to 150 °C [-40 °F to 302 °F]	2.7	5.0	7.0	Vdc
Supply current	G < 25 , V _s = 5 V, 25 °C [77°F] -40 °C to 150 °C [-40 °F to 302 °F]	–	5.5	–	mA
Output current	–	–	–	4.0	mA
V _{sat}	G > 260	–	–	0.4	Vdc
Output leakage current	G < 25	–	–	10	µA
Output rise time	25 °C [77 °F]	–	–	1.5	µs
Output fall time	25 °C [77 °F]	–	–	1.5	µs
Thermal resistance: SS345PT SS445P	–	–	303 233	–	°C/W
Operate	-40 °C to 150 °C [-40 °F to 302 °F]	55	180	280	G
Release	-40 °C to 150 °C [-40 °F to 302 °F]	25	105	240	G
Differential	-40 °C to 150 °C [-40 °F to 302 °F]	10	75	140	G
Operating temperature	–	-40 [-40]	–	150 [302]	°C [°F]
Storage temperature	–	-55 [-67]	–	165 [329]	°C [°F]

NOTICE

The magnetic field strength required to cause the switch to change state (operate and release) will be as specified in the magnetic characteristics. To test the switch against the specified magnetic characteristics, the switch must be placed in a uniform magnetic field.



Table 2. SS345PT/SS445P Absolute Maximum Ratings¹

Characteristic	Minimum	Typical	Maximum	Unit
Supply voltage	-0.5	–	7.0	V
Applied output voltage	-0.5	–	7.0	V
Output current	–	–	8.0	mA
Magnetic flux	–	–	no limit	G

Note 1: Absolute maximum ratings are the extreme limits that the device will withstand without damage to the device. However, the electrical and mechanical characteristics are not guaranteed as the maximum limits (above recommended operating conditions) are approached, nor will the device necessarily operate at absolute maximum ratings.

Figure 1. SS345PT/SS445P Current Sinking Output Block Diagram

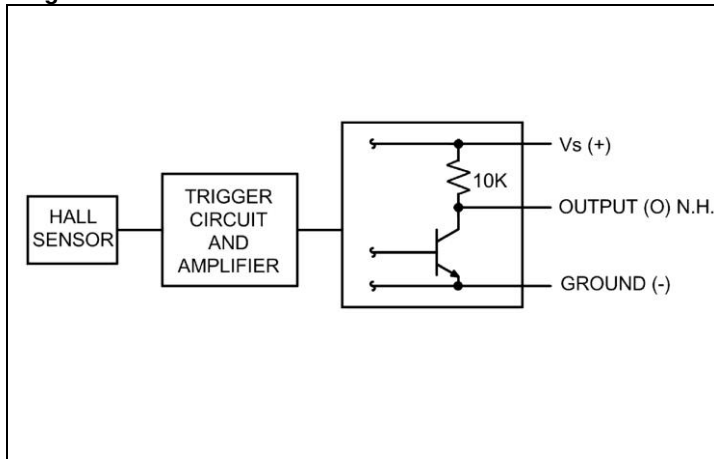
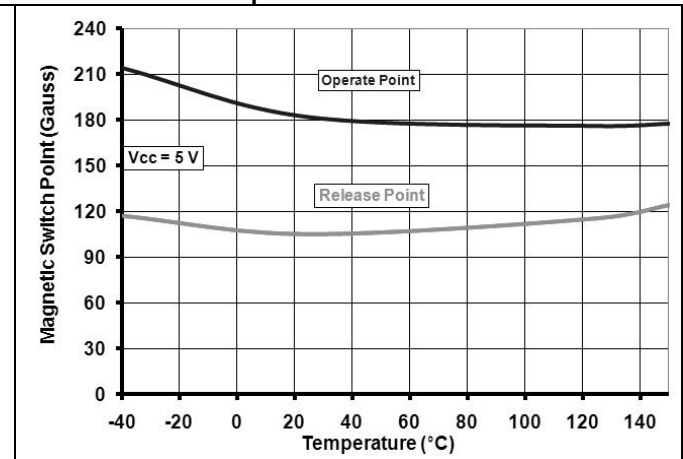

Figure 2. Typical SS345PT/SS445P Magnetic Performance vs Temperature



Unipolar Hall-Effect Digital Position Sensors

Figure 3. SS345PT Mounting/Tape and Reel Dimensions (for reference only. mm/[in])

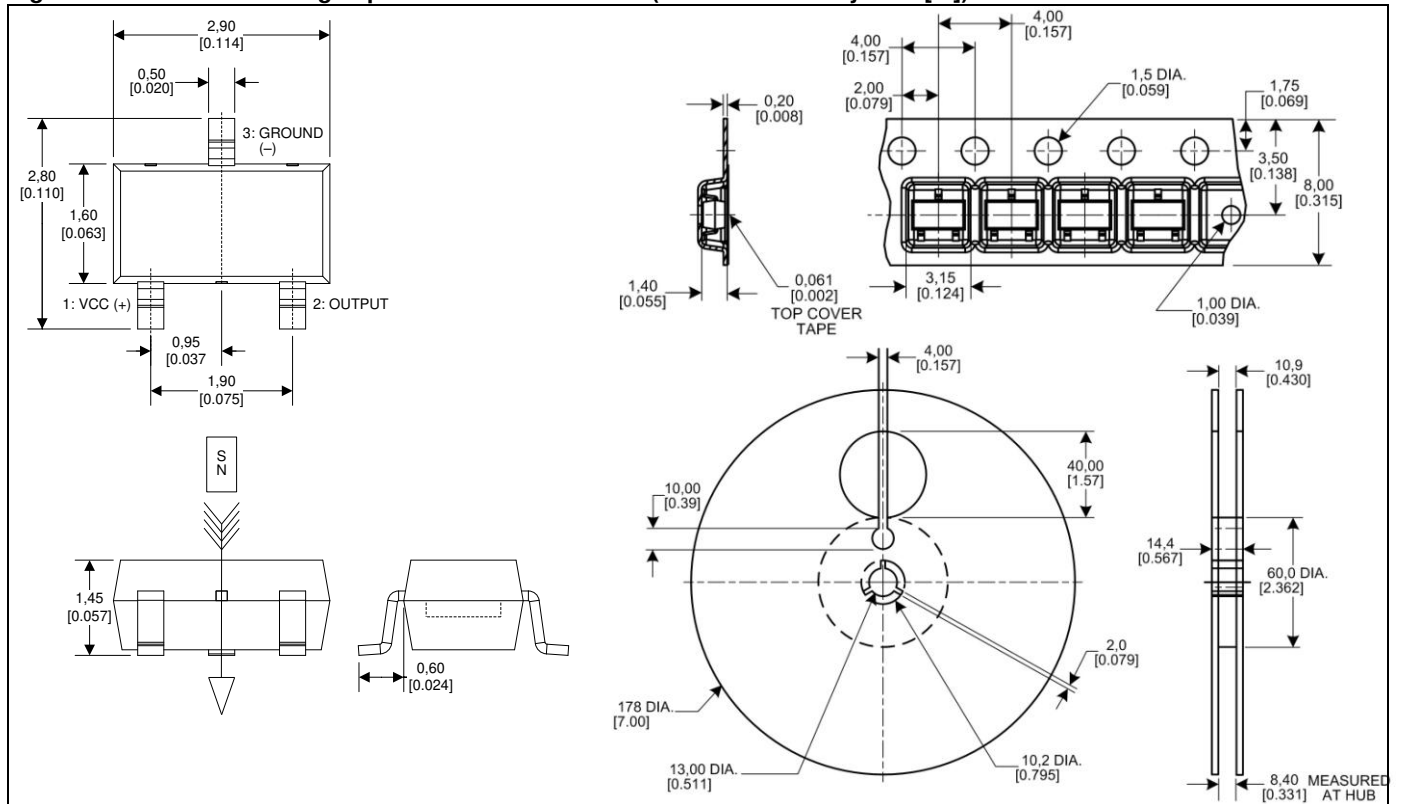
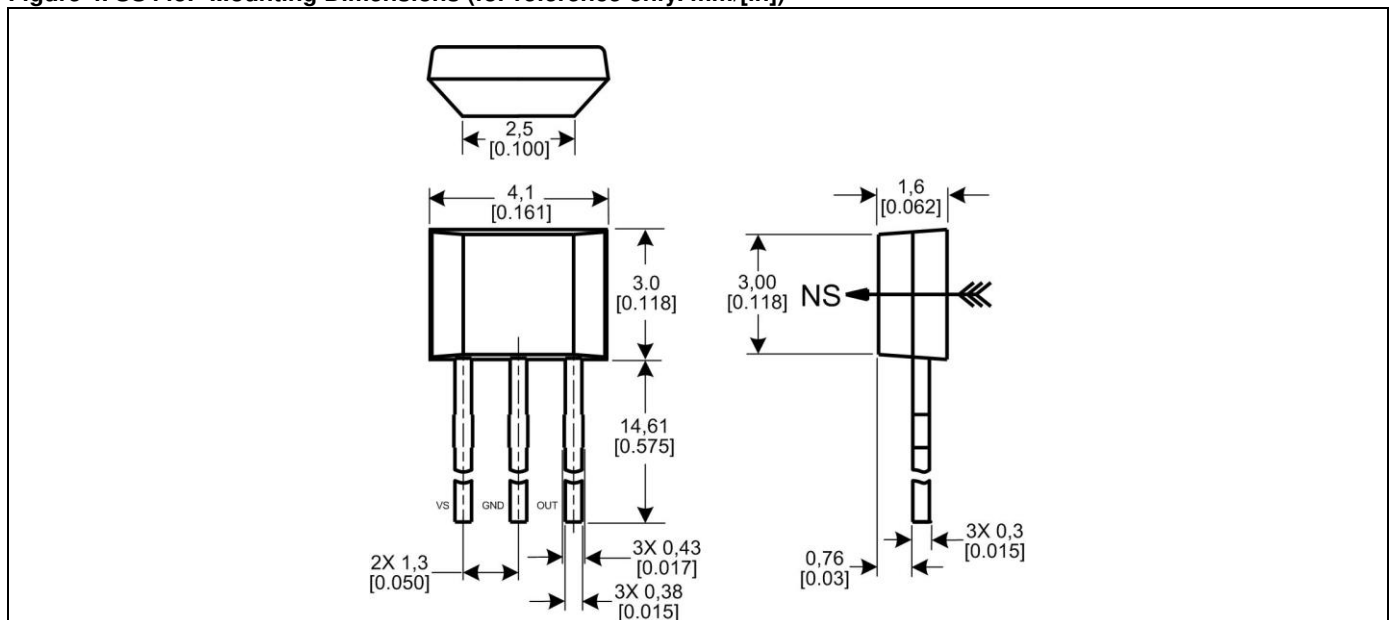

Figure 4. SS445P Mounting Dimensions (for reference only. mm/[in])



Order Guide

Catalog Listing	Description
SS345PT	Unipolar, Hall-effect digital position sensor with built-in pull-up resistor, SOT-23 package, tape and reel packaging (3000 units per reel)
SS445P	Unipolar, Hall-effect digital position sensor with built-in pull-up resistor, flat TO-92 package, bulk packaging (1000 units per bag)

WARNING

PERSONAL INJURY

DO NOT USE these products as safety or emergency stop devices or in any other application where failure of the product could result in personal injury.

Failure to comply with these instructions could result in death or serious injury.

WARRANTY/REMEDY

Honeywell warrants goods of its manufacture as being free of defective materials and faulty workmanship. Honeywell's standard product warranty applies unless agreed to otherwise by Honeywell in writing; please refer to your order acknowledgement or consult your local sales office for specific warranty details. If warranted goods are returned to Honeywell during the period of coverage, Honeywell will repair or replace, at its option, without charge those items it finds defective. **The foregoing is buyer's sole remedy and is in lieu of all other warranties, expressed or implied, including those of merchantability and fitness for a particular purpose. In no event shall Honeywell be liable for consequential, special, or indirect damages.**

While we provide application assistance personally, through our literature and the Honeywell web site, it is up to the customer to determine the suitability of the product in the application.

Specifications may change without notice. The information we supply is believed to be accurate and reliable as of this printing. However, we assume no responsibility for its use.

WARNING

MISUSE OF DOCUMENTATION

- The information presented in this product sheet is for reference only. DO NOT USE this document as a product installation guide.
- Complete installation, operation, and maintenance information is provided in the instructions supplied with each product.

Failure to comply with these instructions could result in death or serious injury.

SALES AND SERVICE

Honeywell serves its customers through a worldwide network of sales offices, representatives and distributors. For application assistance, current specifications, pricing or name of the nearest Authorized Distributor, contact your local sales office or:

E-mail: info.sc@honeywell.com

Internet: www.honeywell.com/sensing

Phone and Fax:

Asia Pacific	+65 6355-2828 +65 6445-3033 Fax
Europe	+44 (0) 1698 481481 +44 (0) 1698 481676 Fax
Latin America	+1-305-805-8188 +1-305-883-8257 Fax
USA/Canada	+1-800-537-6945 +1-815-235-6847 +1-815-235-6545 Fax

Sensing and Control
Honeywell
1985 Douglas Drive North
Golden Valley, MN 55422
www.honeywell.com/sensing

005921-2-EN
November 2011
© 2011 Honeywell International Inc. All rights reserved.

Honeywell