

Product Manual

Vandal-proof latching action switch MSM LA

CONTENTS

1	PRODUCT DESCRIPTION	2
2	TECHNICAL DATA AND DIMENSIONAL DRAWINGS	2
2.1	Technical Data	2
2.2	Dimensional Drawings	5
2.3	Hole Dimensions	7
2.4	Starting Torque.....	7
2.5	Switching Symbols.....	8
2.6	Contact Layout	9
3	ORDER NUMBERS	10
3.1	Order Numbers MSM LA	10
3.2	Lettering.....	11
4	ASSEMBLY	13
4.1	Installation	13
5	PACKAGING	14
6	QUALIFICATION TEST	15
6.1	IP Protection Class	15
6.2	IK Protection Class	15
6.3	ESD Protection.....	15
6.4	Salt Spray Test.....	15
7	APPROVALS.....	16
8	COMPLIANTS.....	16

Changes that contribute to technical improvement are subject to alternations							
page	issue date:	created by:	amendment date:	released by:	amendment no.:	datasheet no.:	index
1 of 16	04.08.2007	Mangold	30.11.2011	Seiler	10518	105.9526.200	j

1 PRODUCT DESCRIPTION

- housing and actuator are made of high-quality stainless steel
- switch is particularly suitable for use in equipment in harsh environments or for vandal-protected applications
- available with mounting diameters of 19 and 22 mm
- suitable for use in temperatures ranging from -20 °C to +85 °C
- permissible switching voltages up to 125 VDC / 250 VAC
- switching status (ON/OFF) is easy to discern by looking at, or feeling, the resting position of the actuator; in the off state, the actuator position protrudes from the housing; in the ON state, it is depressed into the housing
- with quick connect terminals to allow for fast connections
- point and ring illuminated versions in red, green and blue are available for indicating the switching status or for providing visibility during night-time use
- available in single-pole and double-pole versions

2 TECHNICAL DATA AND DIMENSIONAL DRAWINGS

2.1 Technical Data

Electrical Data		
Switching Voltage max.	[V _{DC}]	30 (125VDC/0,5A) ¹⁾
Switching Voltage max.	[V _{AC}]	250
Switching Current max.	[A _{AC}]	12
Rated Braking Capacity	[W _{AC}]	3000
Lifetime (at 8A / 250 VAC)	[Actuations]	50.000
Lifetime ¹⁾ (at 0,5A / 125 VDC)	[Actuations]	100.000
Initial Contact Resistance (at 12V / 1 ADC)	[mΩ]	< 100
Insulation Resistance (500 VDC)	[MΩ]	> 100

1) Direct current Lifetime testing accomplished for switch element 1682.1101 with an actuation frequency of 1 Hz and an actuation velocity of 100 mm/s.

Ring Illumination (RI)	MSM 19 LA RI and MSM 22 LA RI
Supply Voltage U_{LED} [V _{DC}]	24

Point Illumination (PI)	Attention: Parts are delivered without series resistor.
Characteristics LED red Point Illumination	Forward Current max. 30 mA Forward Voltage at 10 mA = 1.9 VDC Forward Voltage max. = 3.0 VDC
Characteristics LED green Point Illumination	Forward Current max. 30 mA Forward Voltage at 10 mA = 2.1 VDC Forward Voltage max. = 3.0 VDC
Characteristics LED blue Point Illumination	Forward Current max. 20 mA Forward Voltage at 8 mA = 3.7 VDC Forward Voltage max. = 4.5 VDC

Recommendation of series resistors for Point Illumination:

LED-Color	I_D [mA]	I_{DMax} [mA]	$U_V = 5$				$U_V = 12$				$U_V = 24$			
			U_V [V]	R_V [Ω]	R_V^{E24} [Ω]	P_V [W]**	U_V [V]	R_V [Ω]	R_V^{E24} [Ω]	P_V [W]**	U_V [V]	R_V [Ω]	R_V^{E24} [Ω]	P_V [W]
red	10	---	310	330	0,03	1010	1000	0,10	2210	2200	0,22			
	---	30	67	68	0,06	300	300	0,27	700	750	0,63			
green	10	---	290	300	0,03	990	1000	0,10	2190	2200	0,22			
	---	30	67	68	0,06	300	300	0,27	700	750	0,63			
blue	8	---	163	160	0,01	1038	1100	0,07	2538	2700	0,16			
	---	20	25	27	0,01	375	390	0,15	975	1000	0,39			

- I_D LED-Forward Current [8mA/10mA]
- I_{DMax} LED-Forward Current max. [20mA/30mA]
- R_V Series Resistor (calculated)
- R_V^{E24} Series Resistor (regarding E24-Resistor series)
- P_V Power dissipation concerning R_V (calculated)

Mechanical Data		
Actuating Force typ.	[N]	10
Actuating Travel typ.	[mm]	5.2
Lifetime mechanical	[Actuations]	100.000
Contact Gap	[mm]	3
Shock Resistance (DIN EN 50102)	[IK]	07

Starting Torque		MSM 19 LA	MSM 22 LA
Plastic Nut max.	[Nm]	4.5	3.5
Stainless Steel Nut* max.	[Nm]	12	16

* on request

Climatic Data		
Operating Temperature	[°C]	-20 to +85
Storage Temperature	[°C]	-20 to +85
Degree of Protection (DIN EN 60529)	[IP]	IP 64 Front Side IP 00 Rear Side

Material	
Component	Material with flammability rating
Push button holder	PA66 (UL94-V0 related to d ≥ 1.6 mm)
Intermediate Connector	PA66 (UL94-V0 related to d ≥ 1.6 mm)
Contact Pin Adapter	PA66 (UL94-V0 related to d ≥ 1.6 mm)
Component	Material without flammability rating
Housing	Stainless Steel 1.4305
Actuator (disc, outside housing)	Stainless Steel 1.4305
Illuminated Ring (die-casting, inside housing)	PC
Sealing Ring	NBR70

2.2 Dimensional Drawings

2.2.1 Component Dimensions M19

**MSM 19 LA ST double-pole /
MSM 19 LA LE double-pole**

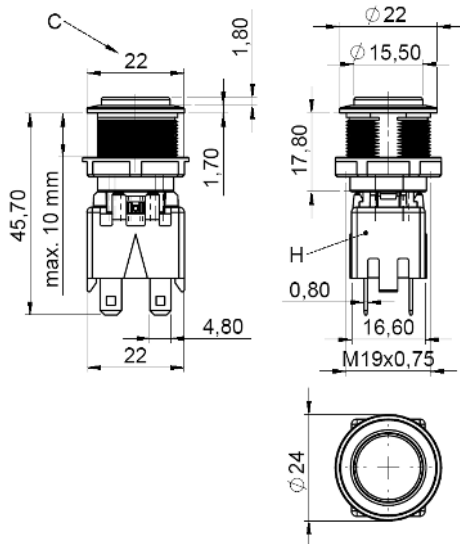

MSM 19 LA PI double-pole

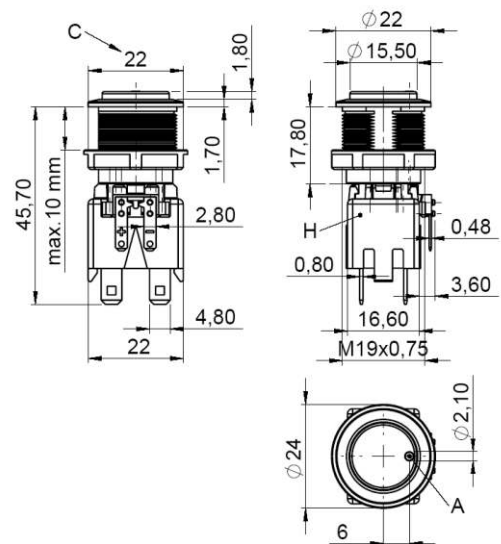

MSM 19 LA RI double-pole

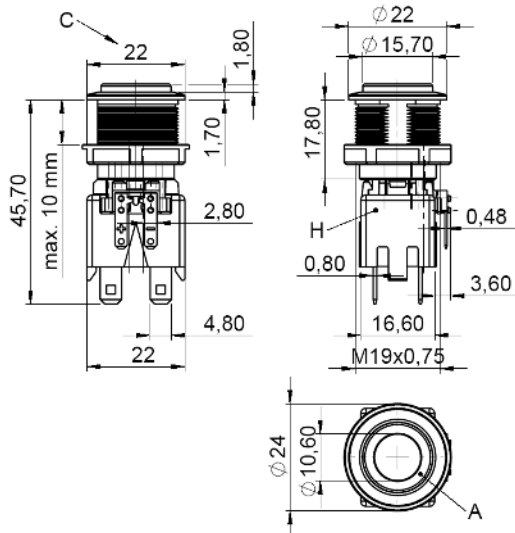

Switching Element single-pole

consists of: switch single-pole + push button holder

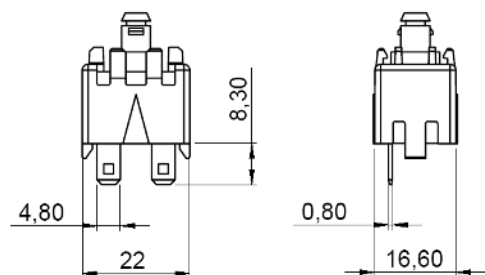

Legend

- A = Illumination Area
- C = Width Across Flats
- H = Switching Element

Changes that contribute to technical improvement are subject to alternations							
page	issue date:	created by:	amendment date:	released by:	amendment no.:	datasheet no.:	index
5 of 16	04.08.2007	Mangold	30.11.2011	Seiler	10518	105.9526.200	j

2.2.2 Component Dimensions M22

**MSM 22 LA ST double-pole /
MSM 22 LA LE double-pole**

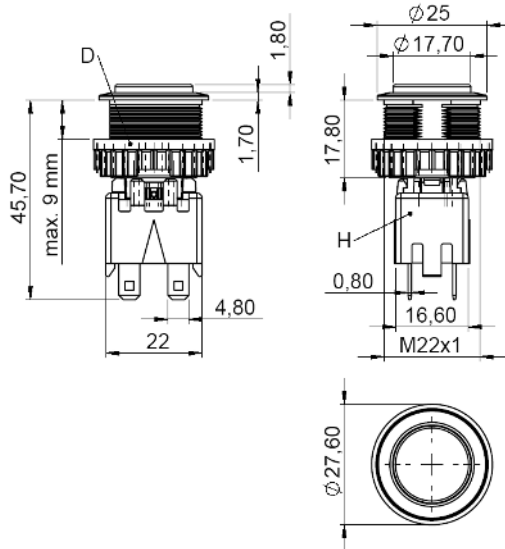

MSM 22 LA PI double-pole

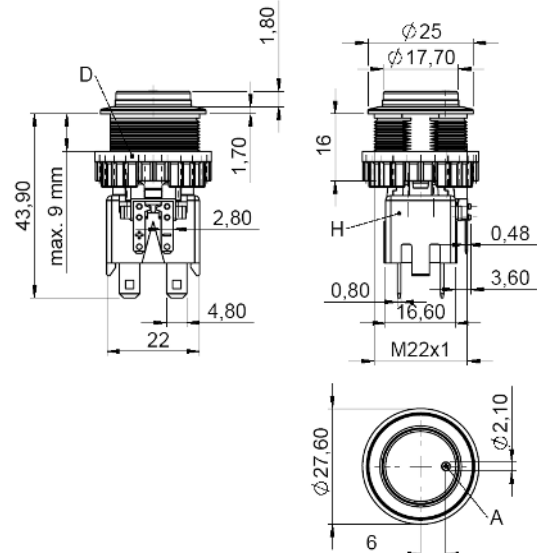

MSM 22 LA RI double-pole

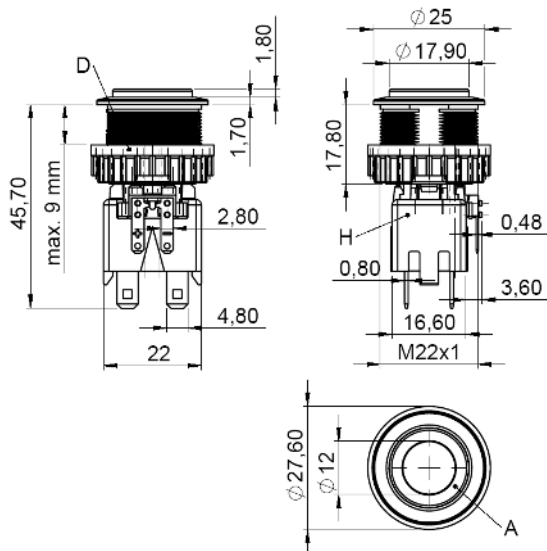

Switching Element single-pole

consists of: switch single-pole + push button holder

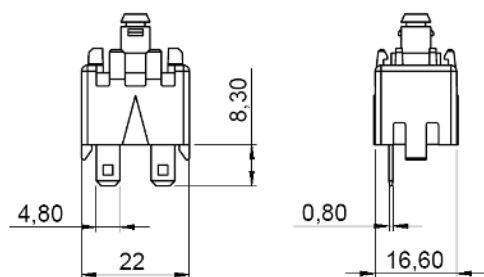

Legend

- A = Illumination Area
- D = Knurled Nut
- H = Switching Element

Changes that contribute to technical improvement are subject to alternations							
page	issue date:	created by:	amendment date:	released by:	amendment no.:	datasheet no.:	index
6 of 16	04.08.2007	Mangold	30.11.2011	Seiler	10518	105.9526.200	j

2.3 Hole Dimensions

MSM 19 LA (without torsion protection)

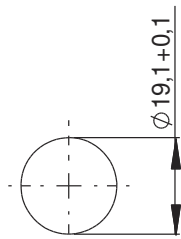

MSM 19 LA (with torsion protection)

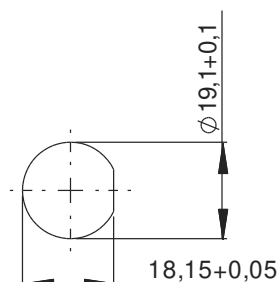

MSM 22 LA (without torsion protection)

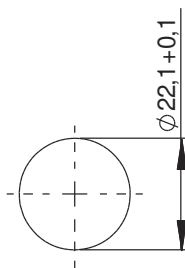

MSM 22 LA (with torsion protection)*

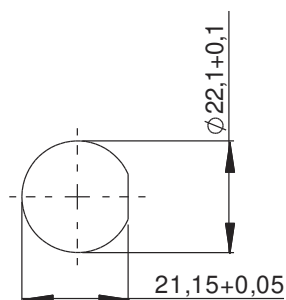

* **Hole Dimensions with torsion protection:**

- recommended for version „Ring Illumination“
- required for version „Point Illumination“ and „Lettered“

2.4 Starting Torque

	Plastic Nut max. (Nm)	Stainless Steel Nut * max. (Nm)
MSM 19	4.5	12
MSM 22	3.5	16

➤ * on request

Changes that contribute to technical improvement are subject to alternations							
page	issue date:	created by:	amendment date:	released by:	amendment no.:	datasheet no.:	index
7 of 16	04.08.2007	Mangold	30.11.2011	Seiler	10518	105.9526.200	j

2.5 Switching Symbols

**MSM LA ST single-pole /
MSM LA LE single-pole**

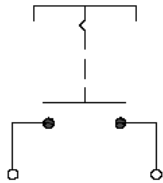

**MSM LA ST double-pole /
MSM LA LE double-pole**

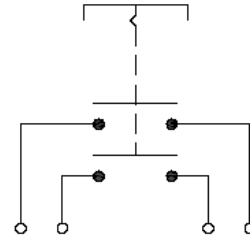

MSM LA PI single-pole

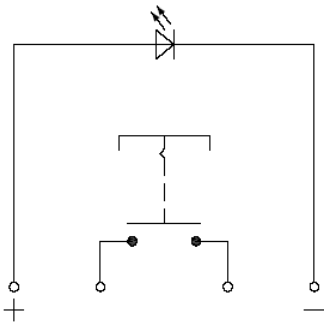

MSM LA PI double-pole

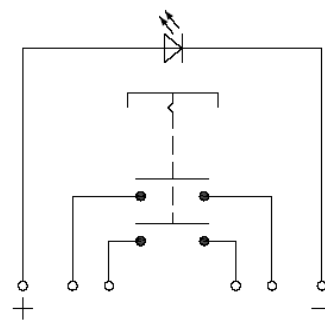

MSM LA RI single-pole

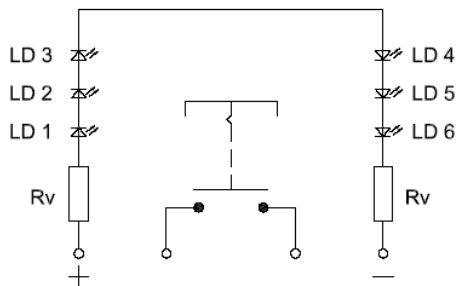

MSM LA RI double-pole

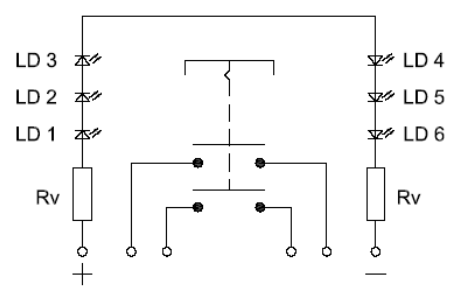

Changes that contribute to technical improvement are subject to alternations

page	issue date:	created by:	amendment date:	released by:	amendment no.:	datasheet no.:	index
8 of 16	04.08.2007	Mangold	30.11.2011	Seiler	10518	105.9526.200	j

2.6 Contact Layout

Contact Layout single-pole

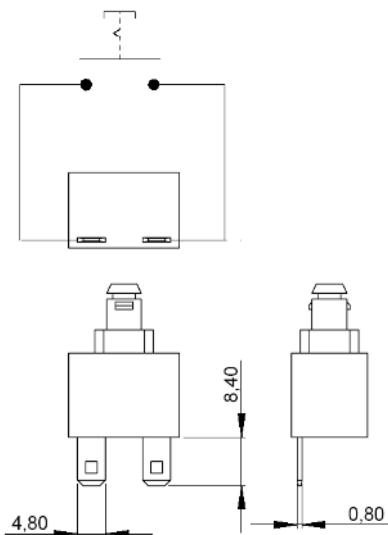

Contact Layout double-pole

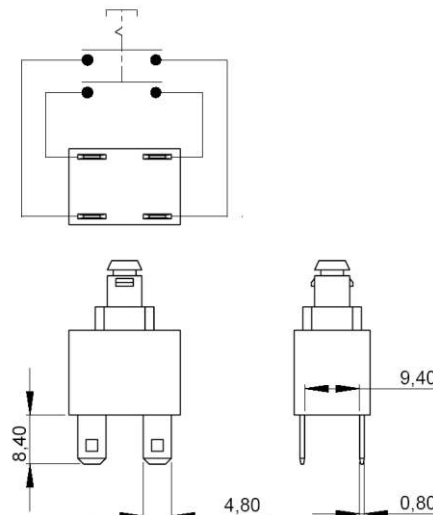

Changes that contribute to technical improvement are subject to alternations							
page	issue date:	created by:	amendment date:	released by:	amendment no.:	datasheet no.:	index
9 of 16	04.08.2007	Mangold	30.11.2011	Seiler	10518	105.9526.200	j

3 ORDER NUMBERS

3.1 Order Numbers MSM LA

Mounting Diameter (mm)	Ø 19	Ø 22
Latching Action Switch, single-pole		
ST (Standard)	1241.6821.1110000	1241.6831.1110000
LE (Lettering) *	1241.6822.1110XXX	1241.6832.1110XXX
PI (Point Illumination) red	1241.6823.1111000	1241.6833.1111000
PI (Point Illumination) green	1241.6823.1112000	1241.6833.1112000
PI (Point Illumination) blue	1241.6823.1114000	1241.6833.1114000
RI (Ring Illumination) red	1241.6824.1111000	1241.6834.1111000
RI (Ring Illumination) green	1241.6824.1112000	1241.6834.1112000
RI (Ring Illumination) blue	1241.6824.1114000	1241.6834.1114000
Latching Action Switch, double-pole		
ST (Standard)	1241.6821.1120000	1241.6831.1120000
LE (Lettering) *	1241.6822.1120XXX	1241.6832.1120XXX
PI (Point Illumination) red	1241.6823.1121000	1241.6833.1121000
PI (Point Illumination) green	1241.6823.1122000	1241.6833.1122000
PI (Point Illumination) blue	1241.6823.1124000	1241.6833.1124000
RI (Ring Illumination) red	1241.6824.1121000	1241.6834.1121000
RI (Ring Illumination) green	1241.6824.1122000	1241.6834.1122000
RI (Ring Illumination) blue	1241.6824.1124000	1241.6834.1124000

* Lettering Index see under [chapter 3.2](#)

3.2 Lettering

The last three digits in the order number define the lettering.

000	No Lettering
001-074	Standard Lettering
101-	Customized Lettering

Example for ordering with lettering

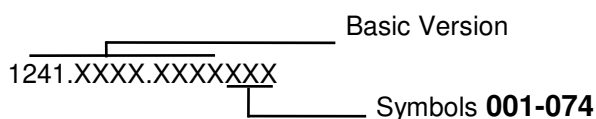

Ordering Indices for Lettering

001= A	016= P	031= 4	046= ↕	061= EIN
002= B	017= Q	032= 5	047= →	062= AUS
003= C	018= R	033= 6	048= ←	063= AUF
004= D	019= S	034= 7	049= ↓	064= AB
005= E	020= T	035= 8	050= ↑	065= ON
006= F	021= U	036= 9	051= %	066= OFF
007= G	022= V	037= +	052= √	067= UP
008= H	023= W	038= –	053= CTRL	068= DOWN
009= I	024= X	039= .	054= RETURN	069= HIGH
010= J	025= Y	040= ×	055= SHIFT	070= LOW
011= K	026= Z	041= ÷	056= LOCK	071= ON/OFF
012= L	027= 0	042= *	057= STOP	072= START
013= M	028= 1	043= =	058= ENTER	073= RESET
014= N	029= 2	044= #	059= BACK	074=
015= O	030= 3	045= ↔	060= LINE	

Lettering Colour of Laser Lettering

<u>Material</u>	<u>Lettering Colour</u>
Stainless Steel	black Filled letters

Changes that contribute to technical improvement are subject to alternations							
page	issue date:	created by:	amendment date:	released by:	amendment no.:	datasheet no.:	index
11 of 16	04.08.2007	Mangold	30.11.2011	Seiler	10518	105.9526.200	j

Font Size

MSM 19 LA LE / MSM 19 LA PI :

Single characters:

Text, max. 3 characters

Text, max. 6 characters:

Symbols (indices 037-052):

height 8 mm, font: Helvetica normal DIN1451-1E

height 3 mm, font: Helvetica normal DIN1451-1E

height 2.5 mm, font: Helvetica condensed DIN1451-3E

capitals height 8 mm, font: True Type, Symbol

MSM 22 LA LE / MSM 22 LA PI :

Single characters:

Text, max. 3 characters

Text, max. 6 characters:

Symbols (indices 037-052):

height 8 mm, font: Helvetica normal DIN1451-1E

height 5 mm, font: Helvetica normal DIN1451-1E

height 2.5 mm, font: Helvetica condensed DIN1451-3E

capitals height 8 mm, font: True Type, Symbol

MSM 19 LA RI * / MSM 22 LA RI

***.**

Single characters:

Text, max. 3 characters

Symbols (indices 037-052):

height 5 mm, font: Helvetica normal DIN1451-1E

height 3 mm, font: Helvetica normal DIN1451-1E

capitals height 5 mm, font: True Type, Symbol

- ** At a minimum order quantity of 100 pieces the ring illuminated version with lettering is available on request.*

Changes that contribute to technical improvement are subject to alternations							
page	issue date:	created by:	amendment date:	released by:	amendment no.:	datasheet no.:	index
12 of 16	04.08.2007	Mangold	30.11.2011	Seiler	10518	105.9526.200	j

4 ASSEMBLY

4.1 Installation

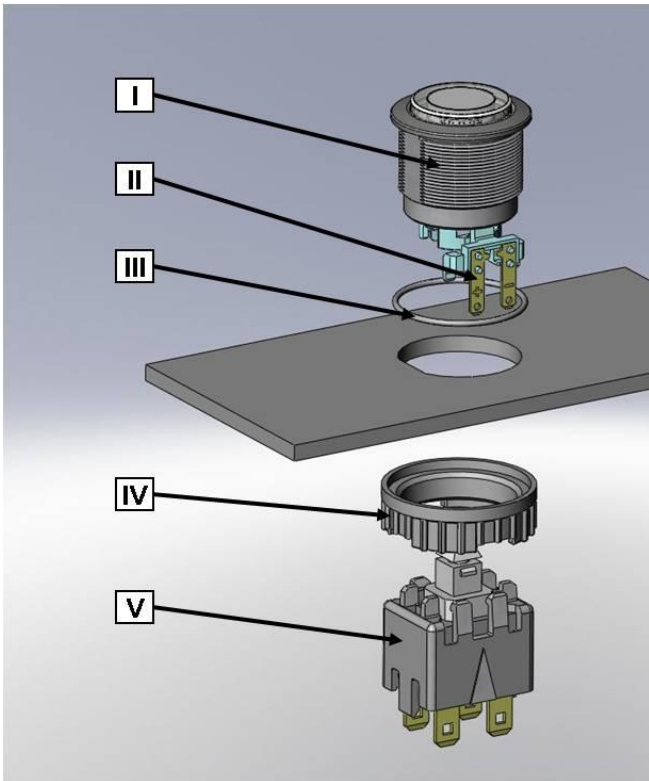

Installation instruction

1. Place the gasket accurately on the actuator housing. Then mount the actuator housing assembly into the panel.
2. Tighten the screw nut with the torque instructions according to [Chapter 2.4](#)
3. Clasp the module switching contact into the actuator housing.

Installation information:

1. The power supply and the configuration of the flat pin terminals has to be installed correctly for the illumination and push button switch function.
2. Insulate the terminals as required. Fully insulated plug-in sleeves are recommended.
3. Installation instructions according to VDE-standard DIN VDE 0100-100 or alternatively IEC 60354 standard. During assembly please mind that there is no tensile or pressure load on the connection of the MSM LA through the cable connection. A corresponding wire lead, running of cables and strain relief has to be arranged.

Legend

- I = Housing Assembly
- II = Flat Pin Terminals (illumination)
- III = Gasket
- IV = Screw Nut
- V = Module Switching Contact

Changes that contribute to technical improvement are subject to alternations							
page	issue date:	created by:	amendment date:	released by:	amendment no.:	datasheet no.:	index
13 of 16	04.08.2007	Mangold	30.11.2011	Seiler	10518	105.9526.200	j

5 PACKAGING

MSM LA

MSM 19 LA	10 pieces per box with inlay
MSM 22 LA	10 pieces per box with inlay

The screw nuts with sealing rings and corresponding switching elements are packed separately and enclosed in the box.



Changes that contribute to technical improvement are subject to alternations							
page	issue date:	created by:	amendment date:	released by:	amendment no.:	datasheet no.:	index
14 of 16	04.08.2007	Mangold	30.11.2011	Seiler	10518	105.9526.200	j

6 QUALIFICATION TEST

6.1 IP Protection Class

IP Protection Class IEC/DIN/EN/60529	IP 64 Front Side IP 00 Rear Side
--------------------------------------	-------------------------------------

6.2 IK Protection Class

Tested centrally

IK Protection Class DIN EN 50102	IK 07
----------------------------------	-------

6.3 ESD Protection

ESD test according to DIN 61000-4-2:

4kV Contact Discharge	MSM LA ST MSM LA LE	Ø 19; 22 mm
-----------------------	------------------------	-------------

6.4 Salt Spray Test

Salt spray test according to DIN 50021- SS
24h, 48h and 96h residence time

The surface of the stainless steel material is covered with a molecular-passive layer. Only under very unfavourable conditions it is possible, that iron and rust molecules as well as base metals penetrate the passive layer as foreign substances (pollutions) and initiate the rust process.

The smoothness of the actuator was not affected. After the residence time the tested samples were cleaned under running water and all rust spots could be removed.

Changes that contribute to technical improvement are subject to alternations							
page	issue date:	created by:	amendment date:	released by:	amendment no.:	datasheet no.:	index
15 of 16	04.08.2007	Mangold	30.11.2011	Seiler	10518	105.9526.200	j

7 APPROVALS

The listed approvals only refer to the push button switch and not to the complete switch.

Push button switch:

Number of Poles of Switch	Push Button Switch Type	Manufacturer	Testing Laboratory	Licence Number
1-pole	1681.1101	Marquardt GmbH	KEMA	2106068.01
			UL / CSA	E41791
2-pole	1682.1101	Marquardt GmbH	KEMA	2106068.01
			UL / CSA	E41791
	for all types		DIN EN	61058-1
			UL	10154

8 COMPLIANTS

All articles are ROHS-compliant and in compliance to the Low Voltage Directive (2006/95/EC).



Changes that contribute to technical improvement are subject to alternations							
page	issue date:	created by:	amendment date:	released by:	amendment no.:	datasheet no.:	index
16 of 16	04.08.2007	Mangold	30.11.2011	Seiler	10518	105.9526.200	j