

PART NO.	ENGINEERING NO.	FINISHED LENGTH
1300061275	105000A07M020	2M [6FT 7 IN]
1300061283	105000A07M050	5M [16FT 5 IN]
1300061296	105000A07M100	10M [32FT 10 IN]
1300061299	105000A07M150	15M [49FT 3 IN]

PART NUMBER LEGEND
105000A07M020

CABLE LENGTH
M050 = 5 METER
M100 = 10 METER
M500 = 50 METER

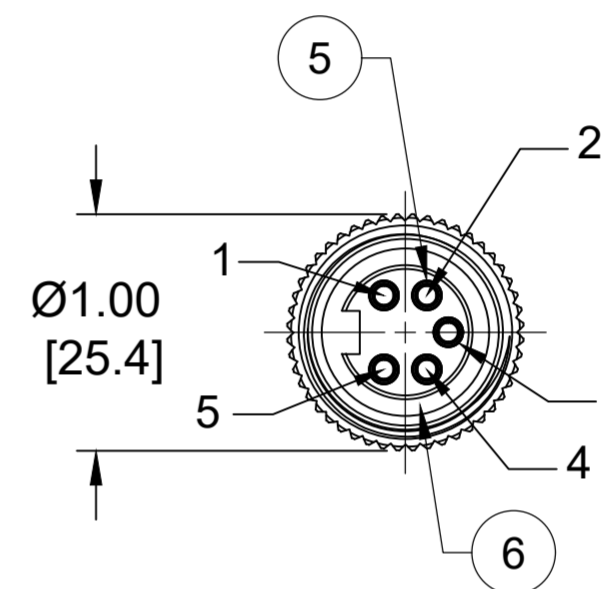
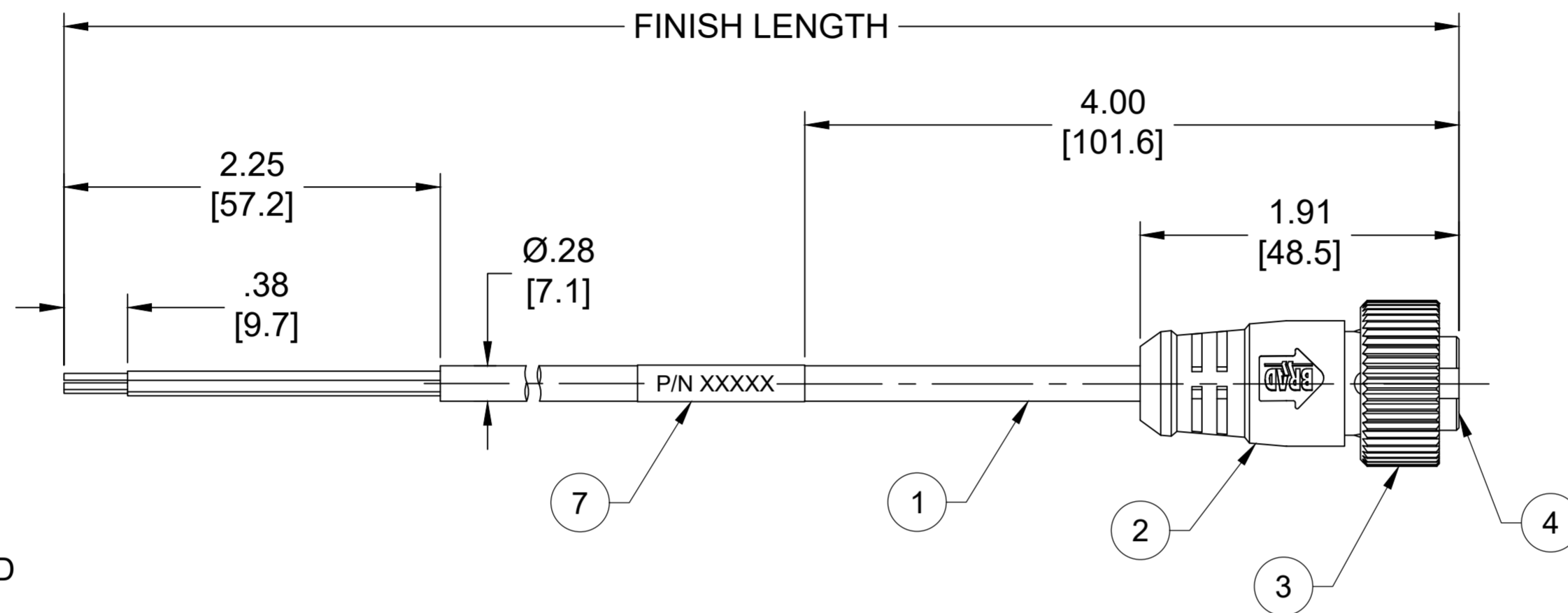
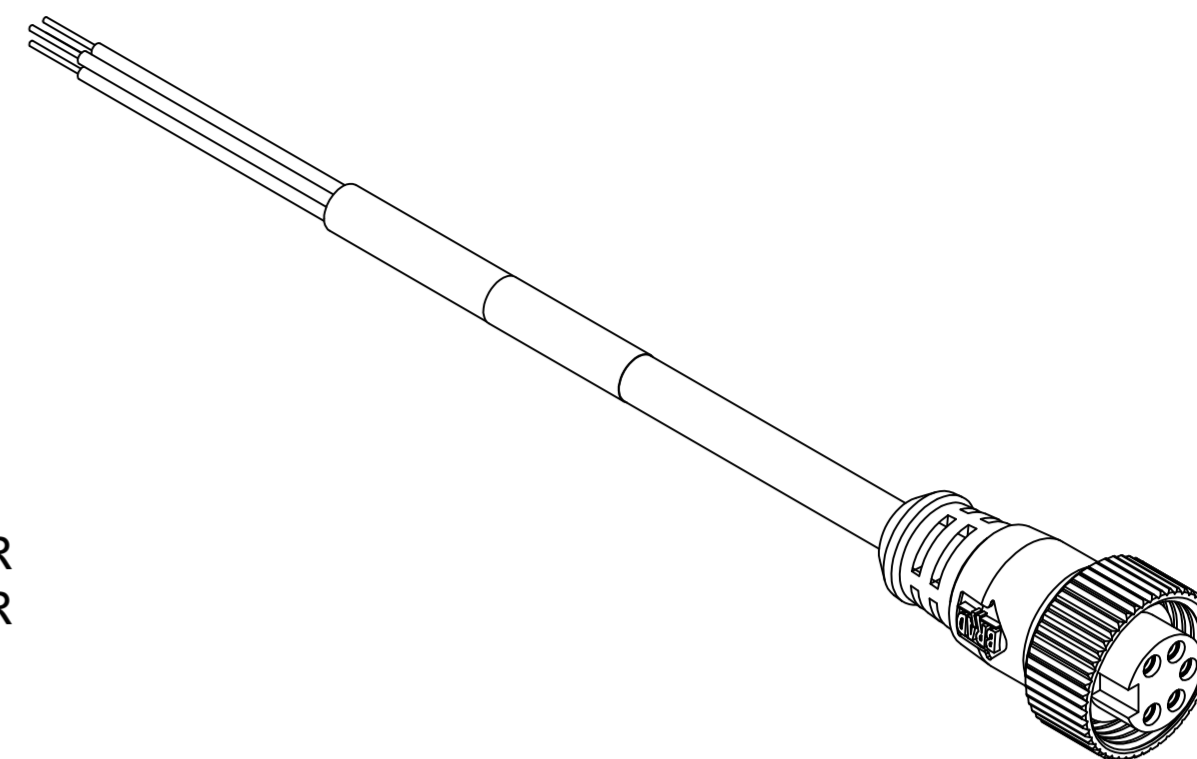

FEMALE FACE VIEW

NOTES:

1. MATERIAL: AS NOTED
2. FINISH: AS NOTED
3. ELECTRICAL:
VOLTAGE : 300V
CURRENT: 4A
4. TEMP RATING: -20° TO +105°C
5. PROTECTION: IP67 (WHEN MATED)
6. COUPLING THREAD: 7/8"-16UN
7. CSA CERTIFIED FILE: LR6837
8. ALL DIMENSIONS ARE FOR REFERENCE UNLESS TOLERANCED OR NOTED OTHERWISE

P1

1	BLACK
2	BLUE
3	GREEN/YELLOW-GND
4	BROWN
5	WHITE

WIRING DIAGRAM

C CABLE LENGTH TOLERANCES

<.3M [1FT]:	+19mm-0 [+.75in-0]
.3 - .9M [1 - 3FT]:	+44.5mm-0 [+1.75in-0]
.9 - 1.8M [3 - 6FT]:	+55.6mm-0 [+2.19in-0]
1.8 - 3.7M [6 - 12FT]:	+88.9mm-0 [+3.50in-0]
3.7 - 7.3M [12 - 24FT]:	+165.1mm-0 [+6.50in-0]
7.3-14.6M [24 - 48FT]:	+317.5mm-0 [+12.50in-0]
14.6 - 30.5M [48-100FT]:	+622.3mm-0 [+24.50in-0]
OVER 30M [100FT]	+2% OF FINISHED LENGTH

ITEM	COMPONENT	MATERIAL	FINISH
7	WRAP LABEL	VINYL	BLACK/YELLOW
6	FRICITION RING	NYLON	WHITE
5	CONTACT SOCKET	COPPER ALLOY	GOLD OVER NICKEL
4	INSERT	TPE	YELLOW
3	COUPLING NUT	ZINC DIE CAST	BLACK-E-COAT
2	OVERMOLD	TPE	YELLOW
1	CABLE, 20 AWG	PVC	YELLOW

FUNCTIONAL SYMBOLS FA=0 FC=0 FP=0	DIMENSION UNITS INCH/MM	SCALE NTS	CURRENT REV DESC: ITEM# 2 & 4 WERE PVC.ITEM #7 WAS PLASTIC FILM. ADDED FRICTION RING, PN LEGEND & TOL CHART. MODIFIED PN CHART.	
	GENERAL TOLERANCES (UNLESS SPECIFIED)		EC NO: 698297	DRWN: ABENJAMINLW 2021/05/17
DIVISIONAL SYMBOLS	4 PLACES ±----	±----	CHK'D: RSTONE 2022/03/16	APPR: BWOODMAN 2022/03/26
	3 PLACES ±----	±----	INITIAL REVISION:	
	2 PLACES ±----	±----	DRWN: TWOLDEGE 2009/07/22	APPR: JFMURPHY 2009/08/10
	1 PLACE ±----	±----	THIRD ANGLE PROJECTION	
	0 PLACES ±----	±----	DRAWING C-SIZE	SERIES 130006
	ANGULAR TOL ± ---- °		MATERIAL NUMBER SEE CHART	CUSTOMER GENERAL MARKET
	DRAFT WHERE APPLICABLE MUST REMAIN WITHIN DIMENSIONS		DOCUMENT NUMBER SD-130006-013	DOC TYPE/DOC PART/REVISION PSD 001 C
			SHEET NUMBER 1 OF 1	