

APPROVED: _____
 DATE: _____ TITLE: _____

Rev	AWO #	Description	Date	Appr
-		RELEASED	11/1/22	
A		UPDATE SPEC.	11/30/22	WX/RC

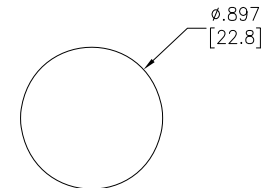
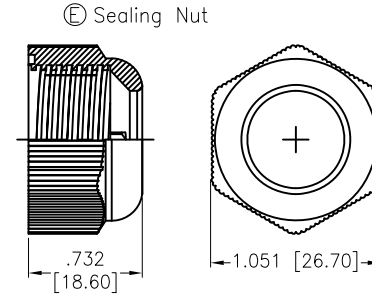
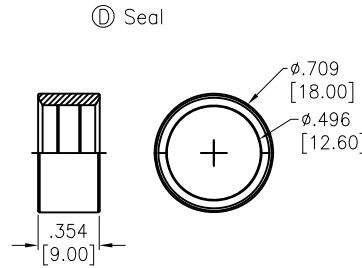
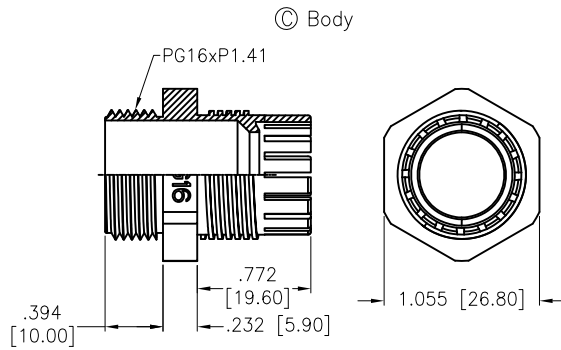
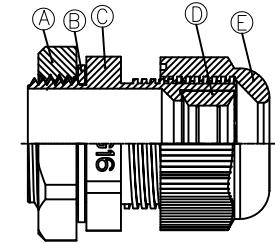
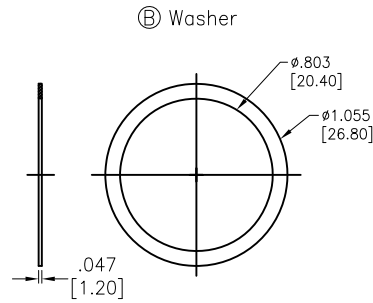
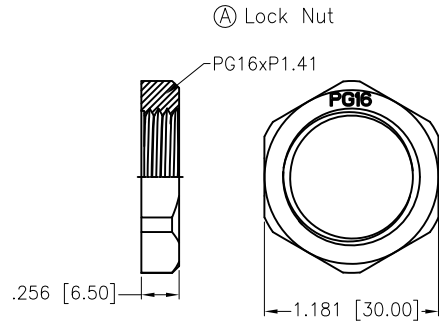

RECOMMENDED
 PANEL CUT-OUT
 (.090 [2.3] MAX PANEL THICKNESS)

SPECIFICATIONS:
 Material:
 Lock Nut: PA66, rated UL 94V-2
 Body: PA66, rated UL 94V-2
 Sealing Nut: PA66, rated UL 94V-2
 Washer: Nitrile Butylene
 Seal: Nitrile Butylene
 Mechanical:
 Cable Range O.D.: 8-13 mm
 Thread O.D. L2: 22.5mm
 Thread Length L2: 10 mm
 Spanner Size A&E: 30/27mm
 Nut Torque: 2.5Nm Max.
 Temperature Rating:
 -40°C to +100°C
 Environmental:
 Waterproof: IP68
 Lead free, RoHS compliant.



UNLESS OTHERWISE SPECIFIED ALL DIMENSIONS ARE INCHES [MM]. TOLERANCES: EXCEPT AS NOTED		
INCHES	HOLES	
.X ± .10	ØX	± .10
.XX ± .020	ØXX	± .015
.XXX ± .015	ØXXX	± .010
DRAWN	JJ	11/1/22
CHECKED	RC	11/1/22
APPROVED		
THIS DRAWING CONTAINS INFORMATION THAT IS PROPRIETARY AND SHOULD NOT BE USED WITHOUT PRIOR WRITTEN PERMISSION FROM ADAM TECH		

ADAM TECH 909 Rahway Avenue,
 Union, NJ 07083
 Phone: 908-687-5000
 Fax: 908-687-5710

TITLE		REV.
WATERPROOF CONNECTOR, PG16, 1 HOLE, CABLE GLAND, WATERPROOF: IP68		
SIZE	PART NO.	A
X	CG-P-16	
REF: S00211C	SCALE: NTS	SHEET 1 OF 1