

AWR1642 Evaluation Module (AWR1642BOOST) Single-Chip mmWave Sensing Solution

The AWR1642 BoosterPack™ from Texas Instruments™ is an easy-to-use evaluation board for the AWR1642 mmWave sensing device, with direct connectivity to the microcontroller (MCU) LaunchPad™ Development Kit. The BoosterPack contains everything required to start developing software for on-chip C67x DSP core and low-power Arm® R4F controllers, including onboard emulation for programming and debugging as well as onboard buttons and LEDs for quick integration of a simple user interface.

Contents

1	Getting Started	2
1.1	Introduction	2
1.2	Key Features	2
1.3	Kit Contents.....	2
2	Hardware.....	3
2.1	Block Diagram.....	5
2.2	Power Connections.....	6
2.3	Connectors	6
2.4	PC Connection.....	10
2.5	Connecting the BoosterPack to the LaunchPad or the MMWAVE-DEVPACK.....	10
2.6	Antenna.....	12
2.7	Jumpers, Switches, and LEDs.....	14
3	Design Files and Software Tools.....	17
3.1	Hardware	17
3.2	Software, Development Tools, and Example Code.....	17
4	Design Revision History	18
5	Mechanical Mounting of PCB.....	18
6	PCB Storage and Handling Recommendations	18
7	Regulatory Information	19
8	Troubleshooting	19
9	References	19

Trademarks

BoosterPack, Texas Instruments, LaunchPad, Code Composer Studio are trademarks of Texas Instruments.

Arm is a registered trademark of Arm Limited.

Windows is a registered trademark of Microsoft Corporation.

All other trademarks are the property of their respective owners.

1 Getting Started

1.1 Introduction

The AWR1642 BoosterPack from Texas Instruments is an easy-to-use evaluation board for the AWR1642 mmWave sensing device, with direct connectivity to the microcontroller (MCU) LaunchPad Development Kit. The BoosterPack contains everything required to start developing software for on-chip C67x DSP core and low-power ARM R4F controllers, including onboard emulation for programming and debugging as well as onboard buttons and LEDs for quick integration of a simple user interface.

The standard 20-pin BoosterPack headers make the device compatible with a wide variety of TI MCU LaunchPads and enables easy prototyping.

1.2 Key Features

- Two 20-pin LaunchPad connectors that leverages the ecosystem of the TI LaunchPad
- XDS110 based JTAG emulation with a serial port for onboard QSPI flash programming
- Back-channel UART through USB-to-PC for logging purposes
- Onboard antenna
- 60-pin, high-density (HD) connector for raw analog-to-digital converter (ADC) data over LVDS and trace-data capability
- Onboard CAN-FD transceiver
- One button and two LEDs for basic user interface
- 5-V power jack to power the board

1.3 Kit Contents

The following items are included with the AWR1642BOOST kit.

- AWR1642BOOST evaluation board
- Mounting brackets, screws, and nuts to place the printed-circuit board (PCB) vertical
- Micro USB cable to connect to PC

NOTE: A 5-V, > 2.5-A supply brick with a 2.1-mm barrel jack (center positive) is not included. TI recommends using an external power supply that complies with applicable regional safety standards, such as UL, CSA, VDE, CCC, PSE, and more. The length of the power cable should be < 3 m.

1.3.1 mmWave Proximity Demo

TI provides sample demo codes to easily get started with the AWR1642 evaluation module (EVM) and to experience the functionality of the AWR1642 radar sensor. For details on getting started with these demos, see www.ti.com/tool/mmwave-sdk.

2 Hardware

Figure 1 and Figure 2 show the front and rear view of the EVM, respectively.

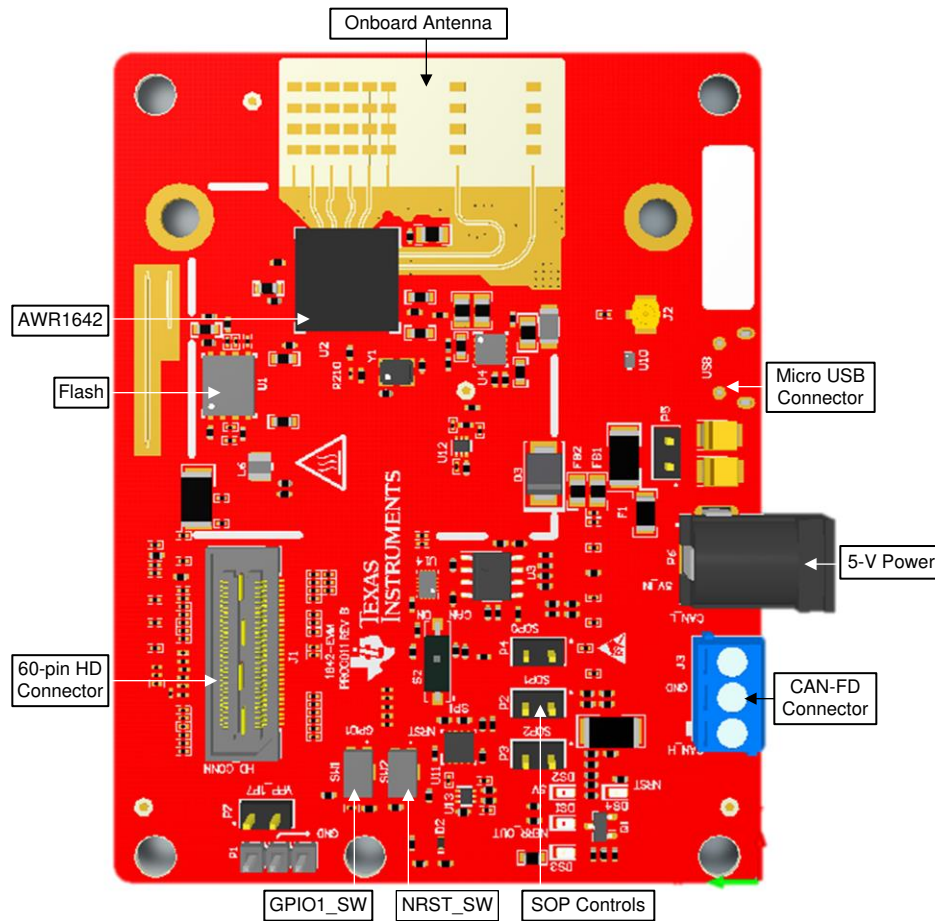

Figure 1. EVM (Front)

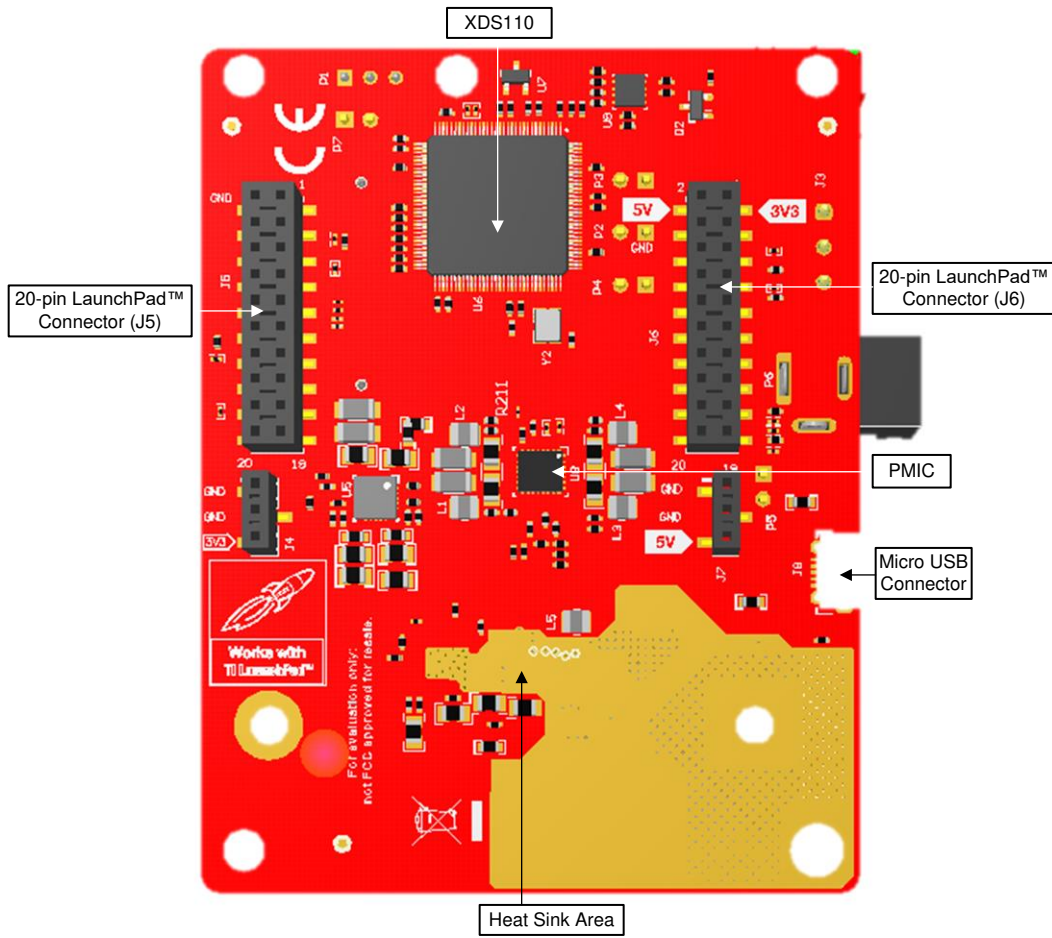
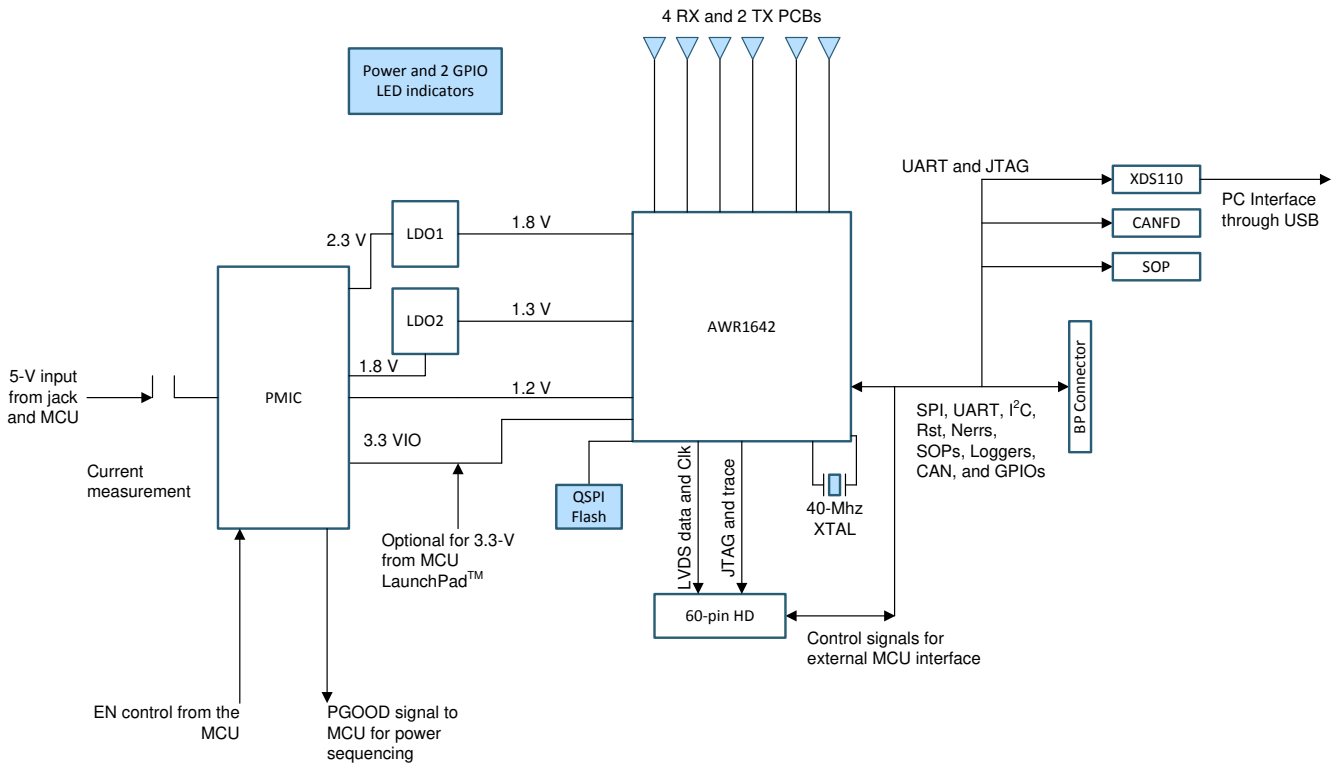

Figure 2. EVM (Rear)

2.1 Block Diagram

Figure 3 shows the block diagram.



Copyright © 2017, Texas Instruments Incorporated

Figure 3. Block Diagram

Figure 4. Block Diagram

2.2 Power Connections

The BoosterPack is powered by the 5-V power jack (5-A current limit), shown in [Figure 5](#). As soon as the power is provided, the NRST and 5-V LEDs should glow, indicating that the board is powered on.

NOTE: After the 5-V power supply is provided to the EVM, it is recommended to press the NRST switch (SW2) one time to ensure a reliable boot-up state.



Figure 5. Power Connector

2.3 Connectors

2.3.1 20-Pin BoosterPack Connectors

The BoosterPack has the standard LaunchPad connectors (J5 and J6, shown in [Figure 6](#)) that enable it to be directly connected to all TI MCU LaunchPads. While connecting the BoosterPack to other LaunchPads, ensure the pin-1 orientation is correct by matching the 3V3 and 5-V signal marking on the boards.



Figure 6. 20-Pin BoosterPack Connectors

Table 1 and Table 2 provide the connector-pin information.

Table 1. J5 Connector Pin

Pin Number	Description	Pin Number	Description
1	NERROUT	2	GND
3	NERRIN	4	DSS_LOGGER
5	MCUCLK_OUT	6	SPI_CS
7	NC	8	GPIO01
9	MSS_LOGGER	10	nRESET
11	WARMRST	12	SPI_MOSI
13	BSS_LOGGER	14	SPI_MISO
15	SOP2	16	HOSTINT
17	SOP1	18	GPIO02
19	SOP0	20	NC

Table 2. J6 Connector Pin

Pin Number	Description	Pin Number	Description
1	3V3	2	5 V
3	NC	4	GND
5	RS232RX (Tx from AWR device)	6	ANA1 ⁽¹⁾
7	RS232RX (Rx into AWR device)	8	ANA2 ⁽¹⁾
9	SYNC_IN	10	ANA3 ⁽¹⁾
11	NC	12	ANA4 ⁽¹⁾
13	SPI_CLK	14	PGOOD (onboard VIO) ⁽²⁾
15	GPIO0	16	PMIC Enable ⁽³⁾
17	SCL	18	SYNC_OUT
19	SDA	20	PMIC CLK_OUT

⁽¹⁾ Voltage input to the GPADC available on the AWR1642.

⁽²⁾ Indicates the state of the onboard VIO supply for the AWR device coming from the onboard PMIC. A HIGH on the PGOOD signal (3.3 V) indicates the supply is stable. Because the I/Os are not failsafe, the MCU must not drive any I/O signals to the AWR device before this I/O supply is stable to avoid leakage current into the I/Os.

⁽³⁾ Controls the onboard PMIC enable. The MCU can use this to shut down the PMIC and AWR device during the periods it does not use the AWR device and save power. The power up of the PMIC takes approximately 5 ms once the enable signal is made high.

2.3.2 60-Pin HD Connector

The 60-pin HD connector provides the high speed LVDS data, control signals (SPI, UART, I²C, NRST, NERR, SOPs) and JTAG debug signals. The connector can be connected to the MMWAVE-DEVPACK board to further get to the standard TSW1400 EVM. [Figure 7](#) shows the HD connector, and [Table 3](#) provides the connector information.



Figure 7. HD Connector

Table 3. J1 Connector Pin

Pin Number	Description	Pin Number	Description
1	5V	2	5V
3	5V	4	TDO
5	TDI	6	TCK
7	SPI_CS	8	TMS
9	SPI_CLK	10	HOSTINT
11	SPI_MOSI	12	SPI_MISO
13	PGOOD (onboard VIO) ⁽¹⁾	14	NERROUT
15	DMM_CLK	16	SYNC_IN
17	DMM_SYNC	18	GND
19	TRACE_DATA0	20	NC
21	TRACE_DATA1	22	NC
23	TRACE_DATA2	24	GND
25	TRACE_DATA3	26	LVDS_FRCLKP
27	TRACE_DATA4	28	LVDS_FRCLKM
29	TRACE_DATA5	30	GND
31	TRACE_DATA6	32	NC
33	TRACE_DATA7	34	NC
35	TRACE_DATA8	36	GND
37	TRACE_DATA9	38	NC
39	TRACE_DATA10	40	NC
41	TRACE_DATA11	42	GND
43	TRACE_DATA12	44	LVDS_CLKP
45	TRACE_DATA13	46	LVDS_CLKM
47	TRACE_DATA14	48	GND
49	TRACE_DATA15	50	LVDS_1P
51	I2C_SDA	52	LVDS_1M
53	I2C_SCL	54	GND
55	RS232RX (Rx into AWR device)	56	LVDS_0P
57	RS232TX (Tx from AWR device)	58	LVDS_0M
59	nRESET	60	GND

⁽¹⁾ Indicates the state of the onboard VIO supply for the AWR device coming from the onboard PMIC. A HIGH on the PGOOD signal (3.3 V) indicates the supply is stable. Because the I/Os are not failsafe, the MCU must not drive any I/O signals to the AWR device before this I/O supply is stable to avoid leakage current into the I/Os.

2.3.3 CAN Interface Connector

The J3 connector provides the CAN_L and CAN_H signals from the onboard CAND-FD transceiver (TCAN1042HGVDRQ1). These signals can be directly wired to the CAN bus.

Because the digital CAN signals (Tx and Rx) are muxed with the SPI interface signals on the AWR device, one of the two paths must be selected. In the Rev A of the board, to enable the CAN interface, R11 and R12 resistors must be populated with 0 Ω ; R4, R6, R28, and R63 resistors must be removed to disconnect the SPI path. In the Rev B board, this is done by placing the switch S2 on the "CAN" position.

Figure 8 shows the CAN connector.

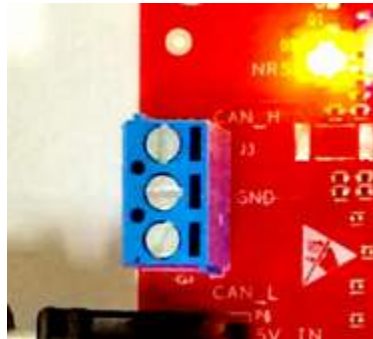

Figure 8. CAN Connector

2.4 PC Connection

The connectivity is provided through the micro USB connector over the onboard XDS110 (TM4C1294NCPDT) emulator. This connection provides the following interfaces to the PC:

- JTAG for Code Composer Studio™ (CCS) connectivity
- UART1 for flashing the onboard serial flash, downloading FW through Radar Studio, and getting application data sent through the UART
- MSS logger UART (can be used to get MSS code logs on the PC)

When the USB is connected to the PC, the device manager should recognize the following COM ports, shown in Figure 9:

- XDS110 Class Application/User UART – UART1 port
- XDS110 Class Auxiliary Data Port – MSS logger port

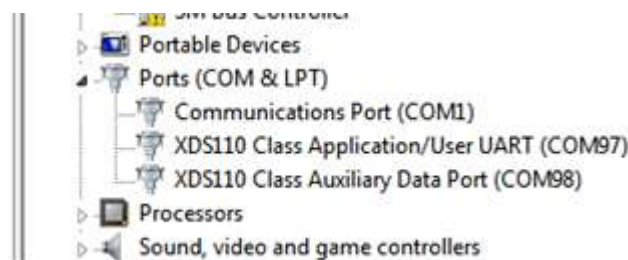

Figure 9. COM Ports

If Windows® is unable to recognize the COM ports, users must install the EMU pack available at [XDS Emulation Software Package](#).

2.5 Connecting the BoosterPack to the LaunchPad or the MMWAVE-DEVPACK

The development pack may be required with the BoosterPack for the following use cases:

- Connecting to Radar Studio
Radar Studio TSW1400+Devpack, mmwave Studio TSW1400+Devpack/DCA1000 tool is a tool that

provides capability to configure the mmWave front end from the PC. This tool is available in the [DFP package](#) and refers to single dfp landing page for both pieces of software.

- Capturing high-speed LVDS data using the SW1400, TSW1400 or DCA1000 FPGA platform from TI (see [High Speed Data Capture and Pattern Generation Platform](#)).

The TSW1400 FPGA platform allows users to capture the raw ADC data over the high-speed debug interface and post process it in the PC.

- Getting DSP trace data through the MIPI 60-pin interface
- Use the DMM interface

This BoosterPack can be stacked on top of the Launchpad or the [MMWAVE-DEVPACK](#) by using the two 20-pin connectors. The connectors do not have a key to prevent the misalignment of the pins or reverse connection. Hence, care must be taken to ensure reverse mounting does not take place.

On the AWR1642 BoosterPack, TI has provided 3V3 markings near pin 1, shown in [Figure 10](#). The same marking is provided on compatible LaunchPads (must be aligned before powering up the boards).

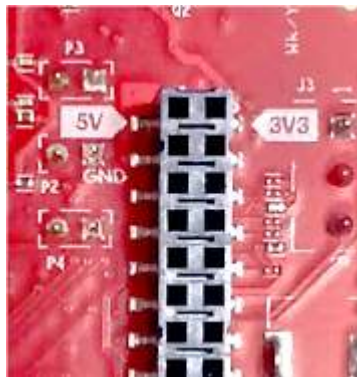

Figure 10. 3V3 and 5V Marking on BoosterPack

For details on these use cases, see the [MMWAVE-DEVPACK User's Guide](#).

NOTE: The DCA1000 EVM has internal DEVPACK functionality. For more information, see the [DCA1000EVM Data Capture Card User's Guide](#).

2.6 Antenna

The BoosterPack includes onboard-etched antennas for the four receivers and two transmitters that enable tracking multiple objects with their distance and angle information. This antenna design enables estimation of distance and elevation angle that enables object detection in a two-dimensional plane. [Figure 11](#) shows the PCB antennas.

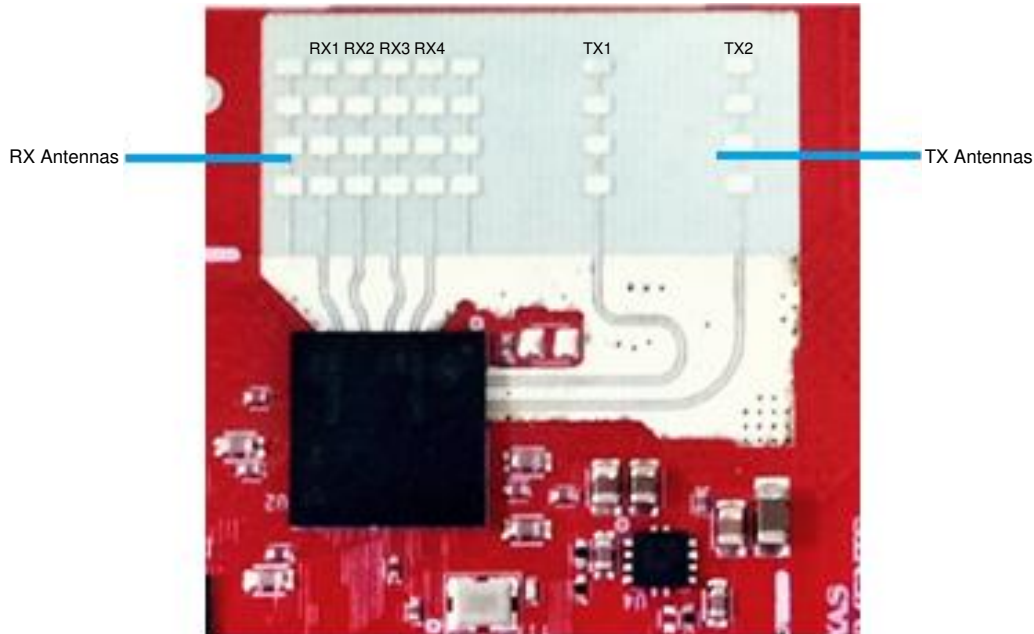

Figure 11. RX and TX Antennas

The antenna peak gain is > 9 dBi across the operating frequency band of 76 to 81 GHz. The peak output power with the antenna gain is < 55 dBm EIRP, as required by the European regulations. The radiation pattern of the antenna in the horizontal plane (H-plane $\Phi = 0$ degrees) and elevation plane (E-plane $\Phi = 90$ degrees) is shown by [Figure 11](#).

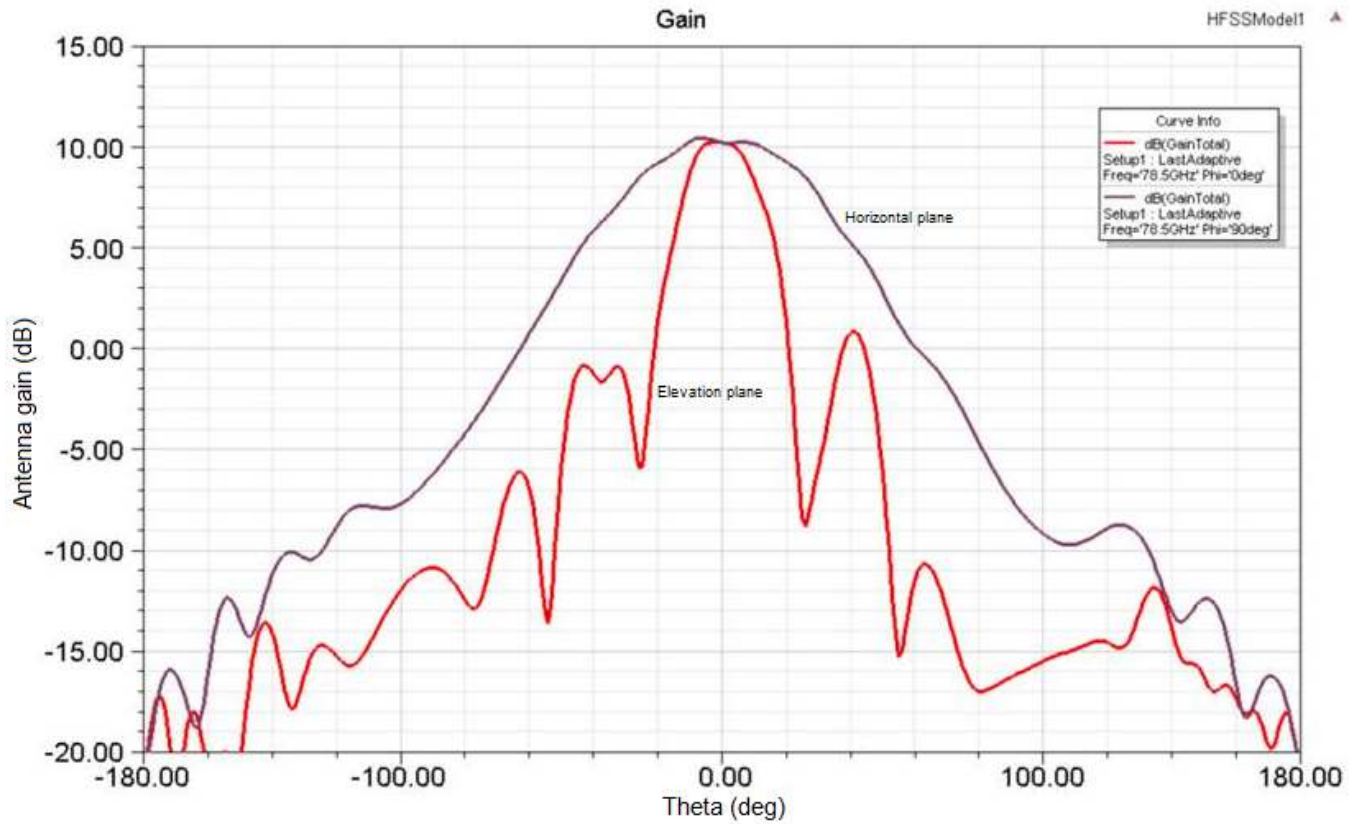

Figure 12. Antenna Pattern

2.7 Jumpers, Switches, and LEDs

2.7.1 Sense-on-Power (SOP) Jumpers

The AWR1642 device can be set to operate in three different modes based on the state of the SOP lines. These lines are sensed only during boot up of the AWR device. The state of the device is detailed by [Table 4](#).

A closed jumpers refers to a 1, and an open jumper refers to a 0 state of the SOP signal going to the AWR device.

Table 4. SOP Jumper Information

Reference		Usage	Comments
P3	SOP 2	SOP[2:0]	101 (SOP mode 5) = flash programming
P2	SOP 1		001 (SOP mode 4) = functional mode
P4	SOP 0		011 (SOP mode 2) = debug mode

Figure 13 shows the SOP jumpers.



Figure 13. SOP Jumpers

2.7.2 Current Measurement

The P5 jumper enables the measurement of the current being consumed by the reference design (AWR device, PMIC, and LDOs) at a 5-V level.

To measure the current, resistor R118 must be removed and a series ammeter can be put across the P5 pins (shown in [Figure 14](#)).



Figure 14. P5 Pins

2.7.3 Push Buttons and LEDs

[Table 5](#) provides the switch and LED information.

Table 5. Switch and LED Information

Reference	Usage	Comments
SW2	RESET	Used to RESET the AWR1642 device. This signal is also brought out on the 20-pin connector and 60-pin HD connector so an external processor can control the AWR device. The onboard XDS110 can also use this reset.
SW1	GPIO_1	When pushed, the GPIO_1 is pulled to V _{CC} .
DS2	5-V supply indication	This LED indicates the presence of the 5-V supply.
DS4	nRESET	This LED is used to indicate the state of nRESET pin. If this LED is glowing, the device is out of reset. This LED will glow only after the 5-V supply is provided.
DS1	Nerr_OUT	Glow if there is any HW error in the AWR device
DS3	GPIO_1	Glow when the GPIO is logic-1

Figure 15 through Figure 20 show the location of switches and LEDs.



Figure 15. SW1



Figure 16. SW2

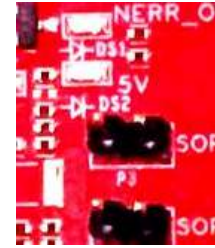

Figure 17. DS2



Figure 18. DS4



Figure 19. DS1



Figure 20. DS3

2.7.4 Selection Between SPI and CAN Interface

The SPI and CAN interface are muxed on the same lines on the AWR1642 device. Based on the configuration, the user can select if the pins E14 and D13 must be connected to the 20-pin/HD connectors to provide the SPI interface OR to the onboard CANFD PHY (U3). This selection is done by the S2 switch. This switch is available on the board from Rev B onwards.

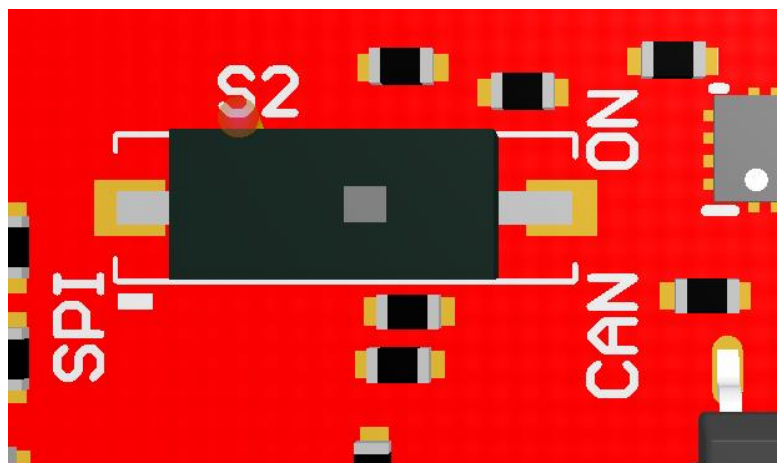

Figure 21. S2 Switch to Select Between SPI or CAN Interface

3 Design Files and Software Tools

3.1 Hardware

To view the schematics, assembly drawings, and BOM, see [AWR1642BOOST Schematic, Assembly Files, and BOM](#).

To view the design database and layout details, see [AWR1642BOOST Hardware Files](#).

NOTE: Boards with a Rev 'C' sticker have had capacitor C56 (VBGAP decoupling capacitor) changed from 0.22 μ F to 0.047 μ F (part number CGA2B3X7R1H473K050BB). TI recommends that customers incorporate this change with an equivalent capacitor in their designs.

3.2 Software, Development Tools, and Example Code

To enable quick development of end applications on the C67x DSP and R4F core in the AWR1642, TI provides a software development kit (SDK) that includes demo codes, software drivers, emulation packages for debug, and more. These can be found at [mmwave-sdk](#).

4 Design Revision History

Table 6. Design Revision History

PCB revision	Change Description
Rev B	Added switch control to move between SPI and CAN interface
	Enabled by default the 5-V supply from the 60-pin HD connector.
	Enabled by default the SYNC_IN signal connection to J6 connector
	Serial flash part number updated to MX25V1635FZNQ
	Added series resistors on I2C lines.
	Removed the series diode on the NRST signal.

5 Mechanical Mounting of PCB

The field of view of the radar sensor is orthogonal to the PCB. To enable easy measurements on the sensing objects on the horizontal plane, the PCB can be mounted vertically. The L-brackets provided with the AWR1642 EVM kit, along with the screws and nuts help in the vertical mounting of the EVM. [Figure 22](#) shows how the L-brackets can be assembled.

Figure 22. Vertical Assembly of EVM

6 PCB Storage and Handling Recommendations

The immersion silver finish of the PCB provides a better high-frequency performance, but is also prone to oxidation in open environments. This oxidation causes the surface around the antenna region to blacken. To avoid oxidation, the PCB should be stored in an ESD cover and kept at a controlled room temperature with low humidity conditions. All ESD precautions must be taken while using and handling the EVM.

7 Regulatory Information

The AWR1642 evaluation module (AWR1642BOOST) is in compliance with Directive 2014/53/EU. The full text of TI's EU Declaration of Conformity is available at the following link:

<http://www.ti.com/tool/awr1642boost>. The compliance has been verified in the operating bands of 76- to 77-GHz and 77- to 81-GHz. Should the user choose to configure the AWR1642BOOST to operate outside of the test conditions it should be operated inside a protected and controlled environment, such as a shielded chamber. This evaluation board is intended only for development and not as an end product or part of an end product. Developers and integrators that incorporate the chipset in any end products are responsible for obtaining applicable regulatory approvals for such end product.

The European RF exposure radiation limit is fulfilled if a minimum distance of 5 cm between the user and the radio transmitter is respected.

NOTE: The AWR1642BOOST has been tested in the 76- to 77-GHz band (2 Tx at a time) at a maximum peak power of 26 dBm EIRP, and in the 77- to 81-GHz band (1 Tx at a time) with maximum peak power of 21 dBm EIRP across the temperature range of -20°C to $+60^{\circ}\text{C}$.

8 Troubleshooting

EVM Board Power-up Failure

See [Section 2.2](#) for desired power connections. Please ensure NRST and 5-V LEDs glow brightly. When a nonfunctional or insufficient current capacity power supply is used with the EVM, the EVM LEDs will not turn on. See [Section 2.7.3](#) for LED information.

9 References

[DCA1000EVM Data Capture Card User's Guide](#)

Revision History

NOTE: Page numbers for previous revisions may differ from page numbers in the current version.

Changes from B Revision (February 2018) to C Revision	Page
• Added Note.	17

IMPORTANT NOTICE AND DISCLAIMER

TI PROVIDES TECHNICAL AND RELIABILITY DATA (INCLUDING DATASHEETS), DESIGN RESOURCES (INCLUDING REFERENCE DESIGNS), APPLICATION OR OTHER DESIGN ADVICE, WEB TOOLS, SAFETY INFORMATION, AND OTHER RESOURCES "AS IS" AND WITH ALL FAULTS, AND DISCLAIMS ALL WARRANTIES, EXPRESS AND IMPLIED, INCLUDING WITHOUT LIMITATION ANY IMPLIED WARRANTIES OF MERCHANTABILITY, FITNESS FOR A PARTICULAR PURPOSE OR NON-INFRINGEMENT OF THIRD PARTY INTELLECTUAL PROPERTY RIGHTS.

These resources are intended for skilled developers designing with TI products. You are solely responsible for (1) selecting the appropriate TI products for your application, (2) designing, validating and testing your application, and (3) ensuring your application meets applicable standards, and any other safety, security, or other requirements. These resources are subject to change without notice. TI grants you permission to use these resources only for development of an application that uses the TI products described in the resource. Other reproduction and display of these resources is prohibited. No license is granted to any other TI intellectual property right or to any third party intellectual property right. TI disclaims responsibility for, and you will fully indemnify TI and its representatives against, any claims, damages, costs, losses, and liabilities arising out of your use of these resources.

TI's products are provided subject to TI's Terms of Sale (www.ti.com/legal/termsofsale.html) or other applicable terms available either on ti.com or provided in conjunction with such TI products. TI's provision of these resources does not expand or otherwise alter TI's applicable warranties or warranty disclaimers for TI products.

Mailing Address: Texas Instruments, Post Office Box 655303, Dallas, Texas 75265
Copyright © 2020, Texas Instruments Incorporated