

4 CIRCUIT SHOWN

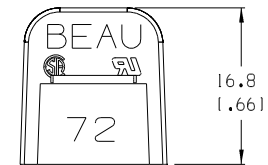
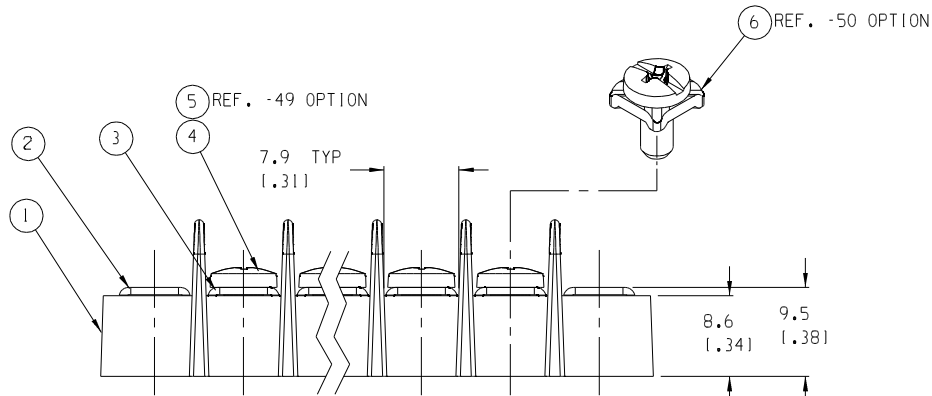

NOTES:

1. MATERIAL: SEE TABLE
2. FINISHES: SEE TABLE
3. PRODUCT SPECIFICATION: NOT REQUIRED
4. PACKAGING: NOT REQUIRED
5. MATES WITH: NONE
6. "XX" REFERS TO THE QUANTITY OF CIRCUITS.
7. REFER TO SD-38120-001 FOR OPTIONAL IMPRINTING (-10A).

ITEM	QTY.	DESCRIPTION	MATERIAL	FINISH
6	XX	SCREW W/WASHER, #6-32X.250 PAN, PHIL-SLOT(-50)	STEEL	ZN, CLEAR CHROMATE
5	XX	SCREW, #6-32 X .250 BHD, PHIL-SLOT (-49)	BRASS	NICKEL PLATE
4	XX	SCREW, #6-32 X .250 BHD, PHIL-SLOT	STEEL	ZN, CLEAR CHROMATE
3	XX	TERMINAL, CB	BRASS	TIN PLATE
2	2	PLATE, MOUNTING	BRASS	NICKEL PLATE
1	1	INSULATOR, SR, CB	THERMOPLASTIC	BLACK

EC NO. RELEASED DRWN: CLY CH: K1 APPR:	DESCRIPTION	QUALITY SYMBOLS
	MAJOR	▲
	CRITICAL	▽
	SPC	△
REV	A1	

GENERAL TOLERANCES: (UNLESS SPECIFIED)	
mm	INCH
4 PLACES	±.0015
3 PLACES	±.038 ±.005
2 PLACES	±.13 ±.01
1 PLACE	±.3
ANGULAR: ±2°	
DRAFT WHERE APPLICABLE MUST REMAIN WITHIN DIMENSIONS	

SCALE: 2:1	DESIGN UNITS: <input type="checkbox"/> mm <input checked="" type="checkbox"/> INCH
DRAWN BY & DATE: C. YORK 09-14-05	
CHECKED BY & DATE:	
APPROVED BY & DATE:	
CAD FILENAME: 721XX	MATERIAL NO.: SEE SHT. 2

THIRD ANGLE PROJECTION
TITLE: 9.53mm (.375") SR BTS, CB ASSY
MOLEX INCORPORATED

PROJECT NO.:	-	-
DIMENSIONS:	SHT	REV
<input checked="" type="checkbox"/> mm <input type="checkbox"/> INCH	<input type="checkbox"/> mm ONLY	REVISE ON CAD ONLY
DRAWING NO.: SD-38720-008	SHEET NO.: 1 OF 2	SIZE: B

NUMBER OF CIRCUITS "XX"	DIM. "A"		DIM. "B"		DIM. "C"		DIM. "D"		ASSEMBLY MATERIAL NO. (STD)	ASSEMBLY MATERIAL NO. (OPT -10A)	ASSEMBLY MATERIAL NO. (OPT -49)	ASSEMBLY MATERIAL NO. (OPT -50)
02	40.2	11.581	9.53	1.3751	28.58	11.1251	21.1	1.831	387200202	387290743	387200802	387201402
03	49.7	11.961	19.05	1.7501	38.10	11.5001	30.7	1.211	387200203		387200803	387201403
04	59.2	12.331	28.58	1.1251	47.63	11.8751	40.2	1.1581	387200204		387200804	387201404
05	68.7	12.711	38.10	11.5001	57.15	12.2501	49.7	11.961	387200205		387200805	387201405
06	78.3	13.081	47.63	11.8751	66.68	12.6251	59.2	12.331	387200206	387290389	387200806	387201406
07	87.8	13.461	57.15	12.2501	76.20	13.0001	68.8	12.711	387200207		387200807	387201407
08	97.3	13.831	66.68	12.6251	85.73	13.3751	78.3	13.081	387200208		387200808	387201408
09	106.8	14.211	76.20	13.0001	95.25	13.7501	87.8	13.461	387200209		387200809	387201409
10	116.4	14.581	85.73	13.3751	104.78	14.1251	97.3	13.831	387200210		387200810	387201410
11	125.9	14.961	95.25	13.7501	114.30	14.5001	106.9	14.211	387200211		387200811	387201411
12	135.4	15.331	104.78	14.1251	123.83	14.8751	116.4	14.581	387200212	387290695	387200812	387201412
13	144.9	15.711	114.30	14.5001	133.35	15.2501	125.9	14.961	387200213		387200813	387201413
14	154.5	16.081	123.83	14.8751	142.88	15.6251	135.4	15.331	387200214		387200814	387201414
15	164.0	16.461	133.35	15.2501	152.40	16.0001	145.0	15.711	387200215		387200815	387201415
16	173.5	16.831	142.88	15.6251	161.93	16.3751	154.5	16.081	387200216		387200816	387201416
17	183.0	17.211	152.40	16.0001	171.45	16.7501	164.0	16.461	387200217		387200817	387201417
18	192.6	17.581	161.93	16.3751	180.98	17.1251	173.5	16.831	387200218		387200818	387201418
19	202.1	17.961	171.45	16.7501	190.50	17.5001	183.1	17.211	387200219		387200819	387201419
20	211.6	18.331	180.98	17.1251	200.03	17.8751	192.6	17.581	387200220		387200820	387201420
21	221.1	18.711	190.50	17.5001	209.55	18.2501	202.1	17.961	387200221		387200821	387201421
22	230.7	19.081	200.03	17.8751	219.08	18.6251	211.6	18.331	387200222		387200822	387201422
23	240.2	19.461	209.55	18.2501	228.60	19.0001	221.2	18.711	387200223		387200823	387201423
24	249.7	19.831	219.08	18.6251	238.13	19.3751	230.7	19.081	387200224		387200824	387201424
25	259.2	110.211	228.60	19.0001	247.65	19.7501	240.2	19.461	387200225		387200825	387201425
26	268.8	110.581	238.13	19.3751	257.18	110.1251	249.7	19.831	387200226		387200826	387201426

EC NO. SEE SHEET 1 DRAWN: CH 'K': APPR: A1	DESCRIPTION MAJOR CRITICAL SPC	QUALITY SYMBOLS		GENERAL TOLERANCES: (UNLESS SPECIFIED)		SCALE: --	DESIGN UNITS: <input type="checkbox"/> mm <input checked="" type="checkbox"/> INCH	THIRD ANGLE PROJECTION	DIMENSIONS: <input checked="" type="checkbox"/> mm <input type="checkbox"/> INCH <input type="checkbox"/> mm ONLY	SHT: REV:	REVISE ON CAD ONLY	
		DRAWN BY & DATE: C. YORK 09-14-05	TITILE: 9.53mm (.375") SR BTS, CB ASSY		APPROVED BY & DATE:			CAD FILENAME: 721XX	MATERIAL NO. SEE CHART	DRAWING NO. SD-38720-008	SHEET NO. 2 OF 2	SIZE B
		CHECKED BY & DATE:	ANGULAR: ±2°		DRAFT WHERE APPLICABLE MUST REMAIN WITHIN DIMENSIONS			THIS DRAWING CONTAINS INFORMATION THAT IS PROPRIETARY TO MOLEX INCORPORATED AND SHOULD NOT BE USED WITHOUT WRITTEN PERMISSION.				
		4 PLACES ±.0015 3 PLACES ±.03B ±.005 2 PLACES ±.13 ±.01 1 PLACE ±.3										