

Surface Mount RF Transformer

50Ω 0.6 to 160 MHz

TC16-161TG2+



Generic photo used for illustration purposes only

CASE STYLE: AT224-3

+RoHS Compliant

The +Suffix identifies RoHS Compliance. See our web site for RoHS Compliance methodologies and qualifications



Available Tape and Reel
at no extra cost

Reel Size	Devices/Reel
7"	20, 50, 100, 200, 500
13"	1000, 2000

Features

- suitable for tin/lead and RoHS solder systems
- excellent amplitude unbalance, 0.1dB typ. and phase unbalance, 0.5 deg. typ.
- aqueous washable

Applications

- impedance matching
- balanced amplifier

Electrical Specifications at 25°C

Parameter	Frequency (MHz)	Min.	Typ.	Max.	Unit
Impedance Ratio (Secondary/Primary)			16		Ohm
Frequency Range		0.6		160	MHz
Insertion Loss*	0.6-160		3		dB
	1.5-120		2		
	3-80		1		

*Insertion Loss is referenced to mid-band loss, 0.6 dB typ.

Maximum Ratings

Parameter	Ratings
Operating Temperature	-40°C to 85°C
Storage Temperature	-55°C to 100°C
RF Power	0.25W
DC Current	30mA

Permanent damage may occur if any of these limits are exceeded.

Pin Connections

Function	Pin Number
PRIMARY DOT	6
PRIMARY	4
SECONDARY DOT	1
SECONDARY CT	2
SECONDARY	3
NOT USED	5

Config. A

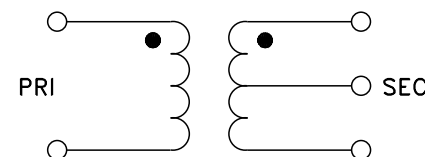

TC16-161TG2+

Outline Drawing

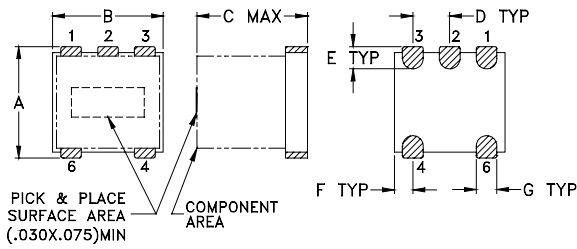

Outline Dimensions (inch/mm)

A	B	C	D	E	F
.150	.150	.150	.050	.030	.025
3.81	3.81	3.81	1.27	0.76	0.64
G	H	J	K	wt	
.028	.065	.190	.030	grams	
0.71	1.65	4.83	0.76	0.10	

PCB Land Pattern

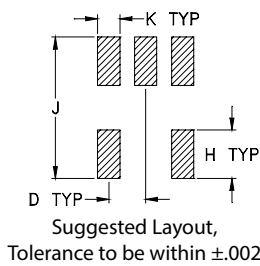

Demo Board MCL P/N: TB-145 Suggested PCB Layout (PL-244)

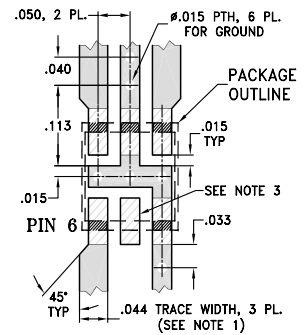

NOTES:

1. THICKNESS .020" ± .0015"; COPPER: 1/2 OZ. ON EACH SIDE. FOR OTHER MATERIALS TRACE WIDTH MAY NEED TO BE MODIFIED.
2. BOTTOM SIDE OF THE PCB IS CONTINUOUS GROUND PLANE.
3. THIS PAD IS NOT REQUIRED FOR AT224 CASE STYLE.
- DENOTES PCB COPPER LAYOUT WITH SMOBC (SOLDER MASK OVER BARE COPPER)
- ▨ DENOTES COPPER LAND PATTERN FREE OF SOLDER MASK

FREQUENCY (MHz)	INSERTION LOSS (dB)	INPUT R. LOSS (dB)
0.60	1.40	14.15
1.00	1.16	17.14
1.50	0.99	19.51
5.00	0.64	29.93
10.00	0.59	36.06
50.00	0.74	16.77
80.00	0.94	12.74
100.00	1.10	10.87
120.00	1.31	9.38
160.00	1.83	7.18

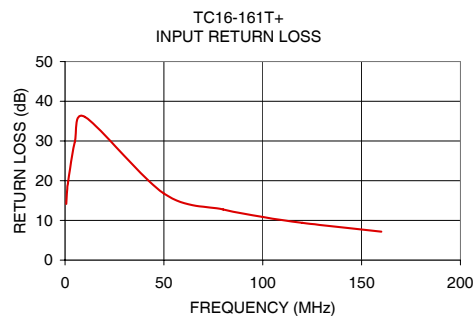
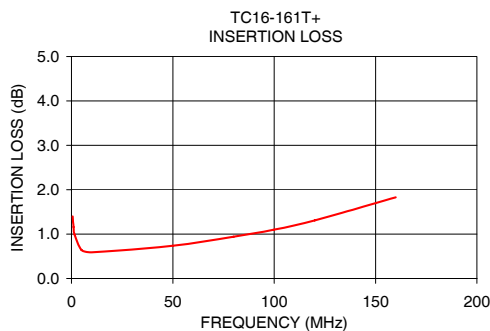

Additional Notes

- A. Performance and quality attributes and conditions not expressly stated in this specification document are intended to be excluded and do not form a part of this specification document.
- B. Electrical specifications and performance data contained in this specification document are based on Mini-Circuit's applicable established test performance criteria and measurement instructions.
- C. The parts covered by this specification document are subject to Mini-Circuits standard limited warranty and terms and conditions (collectively, "Standard Terms"); Purchasers of this part are entitled to the rights and benefits contained therein. For a full statement of the Standard Terms and the exclusive rights and remedies thereunder, please visit Mini-Circuits' website at www.minicircuits.com/MCLStore/terms.jsp