

FEATURES

- RS-232 Bus-Pin ESD Protection Exceeds ±15 kV Using Human-Body Model (HBM)
- Meet or Exceed the Requirements of TIA/EIA-232-F and ITU v.28 Standards
- Operate With 3-V to 5.5-V V_{CC} Supply
- Operate up to 1000 kbit/s
- Five Drivers and Three Receivers
- Auto-Powerdown Plus Feature Enables Flexible Power-Down Mode
- Low Standby Current . . . 1 µA Typical
- External Capacitors . . . 4 × 0.1 µF
- Accept 5-V Logic Input With 3.3-V Supply
- Always-Active Noninverting Receiver Output (ROUT1B)
- ESD Protection for RS-232 Interface Pins
 - ±15 kV – Human-Body Model (HBM)
 - ±8 kV – IEC61000-4-2, Contact Discharge
 - ±15 kV – IEC61000-4-2, Air-Gap Discharge

APPLICATIONS

- Battery-Powered Systems
- PDAs
- Notebooks
- Subnotebooks
- Laptops
- Palmtop PCs
- Hand-Held Equipment
- Modems
- Printers

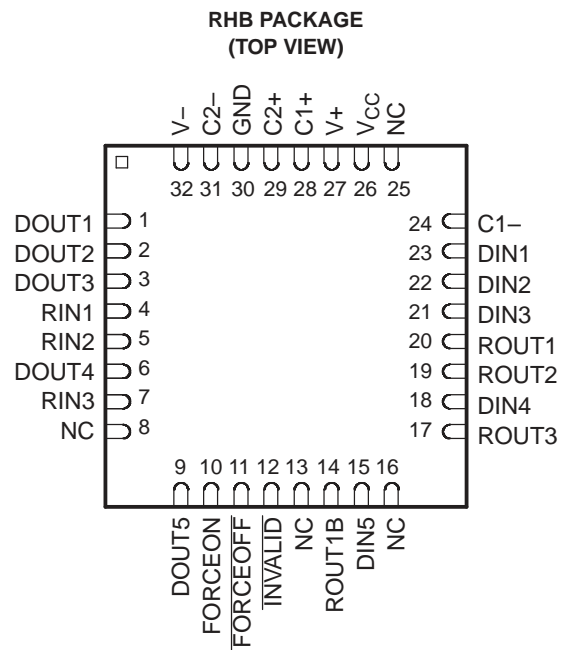
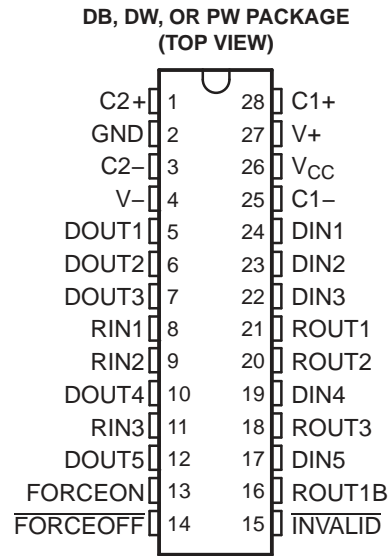

PRODUCT PREVIEW

DESCRIPTION/ORDERING INFORMATION

The SN65C3238E and SN75C3238E consist of five line drivers, three line receivers, and a dual charge-pump circuit with ±15-kV ESD (HBM) protection on the driver output (DOUT) and receiver input (RIN) terminals. The devices meet the requirements of TIA/EIA-232-F and provide the electrical interface between notebook and subnotebook computer applications. The charge pump and four small external capacitors allow operation from a single 3-V to 5.5-V supply. In addition, the devices include an always-active noninverting output (ROUT1B), which allows applications using the ring indicator to transmit data while the device is powered down. These devices operate at data signaling rates up to 1000 kbit/s.



Please be aware that an important notice concerning availability, standard warranty, and use in critical applications of Texas Instruments semiconductor products and disclaimers thereto appears at the end of this data sheet.

DESCRIPTION/ORDERING INFORMATION (CONTINUED)

Flexible control options for power management are featured when the serial port and driver inputs are inactive. The auto-powerdown plus feature functions when FORCEON is low and FORCEOFF is high. During this mode of operation, if the devices do not sense valid signal transitions on all receiver and driver inputs for approximately 30 s, the built-in charge pump and drivers are powered down, reducing the supply current to 1 μ A. By disconnecting the serial port or placing the peripheral drivers off, auto-powerdown plus occurs if there is no activity in the logic levels for the driver inputs. Auto-powerdown plus can be disabled when FORCEON and FORCEOFF are high. With auto-powerdown plus enabled, the devices activate automatically when a valid signal is applied to any receiver or driver input. INVALID is high (valid data) if any receiver input voltage is greater than 2.7 V or less than -2.7 V, or has been between -0.3 V and 0.3 V for less than 30 μ s. INVALID is low (invalid data) if all receiver input voltages are between -0.3 V and 0.3 V for more than 30 μ s. Refer to Figure 5 for receiver input levels.

ORDERING INFORMATION

T _A	PACKAGE ⁽¹⁾		ORDERABLE PART NUMBER	TOP-SIDE MARKING
0°C to 70°C	SSOP – DB	Tube of 50	SN75C3238EDB	75C3238E
		Reel of 2000	SN75C3238EDBR	
	TSSOP – PW	Tube of 50	SN75C3238EPW	Preview
		Reel of 2000	SN75C3238EPWR	
	SOIC – DW	Tube of 50	SN75C3238EDW	75C3238E
		Reel of 2000	SN75C3238EDWR	
	QFN – RHB	Reel of 2000	SN75C3238ECRHBR	Preview
	-40°C to 85°C	SSOP – DB	Tube of 50	SN65C3238EDB
Reel of 2000			SN65C3238EDBR	
TSSOP – PW		Tube of 50	SN65C3238EPW	Preview
		Reel of 2000	SN65C3238EPWR	
SOIC – DW		Tube of 50	SN65C3238EDW	65C3238E
		Reel of 2000	SN65C3238EDWR	
QFN – RHB		Reel of 2000	SN65C3238EIRHBR	Preview

(1) Package drawings, standard packing quantities, thermal data, symbolization, and PCB design guidelines are available at www.ti.com/sc/package.

PRODUCT PREVIEW

FUNCTION TABLES

Each Driver⁽¹⁾

INPUTS				OUTPUT DOUT	DRIVER STATUS
DIN	FORCEON	FORCEOFF	TIME ELAPSED SINCE LAST RIN OR DIN TRANSITION		
X	X	L	X	Z	Powered off
L	H	H	X	H	Normal operation with auto-powerdown plus disabled
H	H	H	X	L	
L	L	H	<30 s	H	Normal operation with auto-powerdown plus enabled
H	L	H	<30 s	L	
L	L	H	>30 s	Z	Powered off by auto-powerdown plus feature
H	L	H	>30 s	Z	

(1) H = high level, L = low level, X = irrelevant, Z = high impedance

Each Receiver⁽¹⁾

INPUTS				OUTPUTS		RECEIVER STATUS
RIN1	RIN2–RIN3	FORCEOFF	TIME ELAPSED SINCE LAST RIN OR DIN TRANSITION	ROUT1B	ROUT2 AND ROUT3	
L	X	L	X	L	Z	Powered off while ROUT1B is active
H	X	L	X	H	Z	
L	L	H	<30 s	L	H	Normal operation with auto-powerdown plus disabled/enabled
L	H	H	<30 s	L	L	
H	L	H	<30 s	H	H	
H	H	H	<30 s	H	L	
Open	Open	H	<30 s	L	H	

(1) H = high level, L = low level, X = irrelevant, Z = high impedance (off), Open = input disconnected or connected driver off

SN65C3238E, SN75C3238E
3-V TO 5.5-V MULTICHANNEL RS-232 LINE DRIVERS/RECEIVERS
WITH ± 15 -kV ESD (HBM) PROTECTION

SLLS726-MAY 2006

LOGIC DIAGRAM (POSITIVE LOGIC)

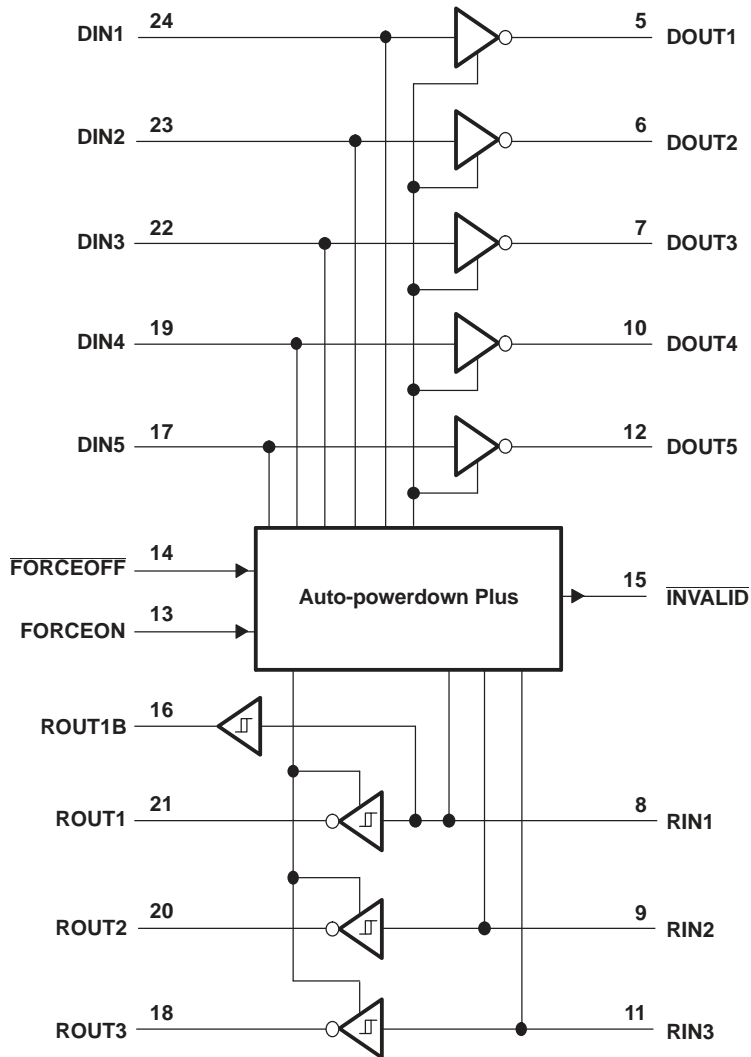

PRODUCT PREVIEW

Absolute Maximum Ratings⁽¹⁾

over operating free-air temperature range (unless otherwise noted)

		MIN	MAX	UNIT	
V _{CC}	Supply voltage range ⁽²⁾	–0.3	6	V	
V+	Positive-output supply voltage range ⁽²⁾	–0.3	7	V	
V–	Negative-output supply voltage range ⁽²⁾	0.3	–7	V	
V+ – V–	Supply voltage difference ⁽²⁾		13	V	
V _I	Input voltage range	Driver (FORCEOFF, FORCEON)	–0.3	6	V
		Receiver	–25	25	
V _O	Output voltage range	Driver	–13.2	13.2	V
		Receiver (INVALID)	–0.3	V _{CC} + 0.3	
θ_{JA}	Package thermal impedance ⁽³⁾⁽⁴⁾	DB package		62	°C/W
		DW package		46	
		PW package		62	
		RHB package		TBD	
T _J	Operating virtual junction temperature		150	°C	
T _{stg}	Storage temperature range	–65	150	°C	

- Stresses beyond those listed under "absolute maximum ratings" may cause permanent damage to the device. These are stress ratings only, and functional operation of the device at these or any other conditions beyond those indicated under "recommended operating conditions" is not implied. Exposure to absolute-maximum-rated conditions for extended periods may affect device reliability.
- All voltages are with respect to network GND.
- Maximum power dissipation is a function of T_J(max), θ_{JA} , and T_A. The maximum allowable power dissipation at any allowable ambient temperature is P_D = (T_J(max) – T_A)/ θ_{JA} . Operating at the absolute maximum T_J of 150°C can affect reliability.
- The package thermal impedance is calculated in accordance with JESD 51-7.

Recommended Operating Conditions⁽¹⁾

See Figure 6

		MIN	NOM	MAX	UNIT
Supply voltage	V _{CC} = 3.3 V	3	3.3	3.6	V
	V _{CC} = 5 V	4.5	5	5.5	
V _{IH} Driver and control high-level input voltage	DIN, FORCEOFF, FORCEON	V _{CC} = 3.3 V	2	5.5	V
		V _{CC} = 5 V	2.4	5.5	
V _{IL} Driver and control low-level input voltage	DIN, FORCEOFF, FORCEON	0		0.8	V
V _I Receiver input voltage		–25		25	V
T _A Operating free-air temperature	SN75C3238E	0		70	°C
	SN65C3238E	–40		85	

- Testing supply conditions are C1–C4 = 0.1 μ F at V_{CC} = 3.3 V \pm 0.15 V; C1–C4 = 0.22 μ F at V_{CC} = 3.3 V \pm 0.3 V; and C1 = 0.047 μ F and C2–C4 = 0.33 μ F at V_{CC} = 5 V \pm 0.5 V.

Electrical Characteristics⁽¹⁾

over recommended ranges of supply voltage and operating free-air temperature (unless otherwise noted) (see Figure 6)

PARAMETER		TEST CONDITIONS	MIN	TYP ⁽²⁾	MAX	UNIT
I _I	Input leakage current	FORCEOFF, FORCEON		± 0.01	± 1	μ A
I _{CC}	Supply current (T _A = 25°C)	Auto-powerdown plus disabled	No load, FORCEOFF and FORCEON at V _{CC}	0.5	2	mA
		Powered off	No load, FORCEOFF at GND	1	10	
		Auto-powerdown plus enabled	No load, FORCEOFF at V _{CC} , FORCEON at GND, All RIN are open or grounded	1	10	μ A

- Testing supply conditions are C1–C4 = 0.1 μ F at V_{CC} = 3.3 V \pm 0.15 V; C1–C4 = 0.22 μ F at V_{CC} = 3.3 V \pm 0.3 V; and C1 = 0.047 μ F and C2–C4 = 0.33 μ F at V_{CC} = 5 V \pm 0.5 V.
- All typical values are at V_{CC} = 3.3 V or V_{CC} = 5 V, and T_A = 25°C.

SN65C3238E, SN75C3238E
3-V TO 5.5-V MULTICHANNEL RS-232 LINE DRIVERS/RECEIVERS
WITH ±15-kV ESD (HBM) PROTECTION

SLLS726–MAY 2006

DRIVER SECTION

Electrical Characteristics⁽¹⁾

over recommended ranges of supply voltage and operating free-air temperature (unless otherwise noted) (see [Figure 6](#))

PARAMETER	TEST CONDITIONS	MIN	TYP ⁽²⁾	MAX	UNIT
V _{OH}	High-level output voltage All DOUT at R _L = 3 kΩ to GND	5	5.4		V
V _{OL}	Low-level output voltage All DOUT at R _L = 3 kΩ to GND	–5	–5.4		V
I _{IH}	High-level input current V _I = V _{CC}		±0.01	±1	μA
I _{IL}	Low-level input current V _I at GND		±0.01	±1	μA
I _{OS}	Short-circuit output current ⁽³⁾ V _{CC} = 3.6 V, V _O = 0 V V _{CC} = 5.5 V, V _O = 0 V		±35	±60	mA
			±40	±100	
r _o	Output resistance V _{CC} , V+, and V– = 0 V, V _O = ±2 V	300	10M		Ω
I _{OZ}	Output leakage current FORCEOFF = GND	V _O = ±12 V, V _{CC} = 3 V to 3.6 V		±25	μA
		V _O = ±10 V, V _{CC} = 4.5 V to 5.5 V		±25	

- (1) Testing supply conditions are C1–C4 = 0.1 μF at V_{CC} = 3.3 V ± 0.15 V; C1–C4 = 0.22 μF at V_{CC} = 3.3 V ± 0.3 V; and C1 = 0.047 μF and C2–C4 = 0.33 μF at V_{CC} = 5 V ± 0.5 V.
- (2) All typical values are at V_{CC} = 3.3 V or V_{CC} = 5 V, and T_A = 25°C.
- (3) Short-circuit durations should be controlled to prevent exceeding the device absolute power dissipation ratings, and not more than one output should be shorted at a time.

Switching Characteristics⁽¹⁾

over recommended ranges of supply voltage and operating free-air temperature (unless otherwise noted) (see [Figure 6](#))

PARAMETER	TEST CONDITIONS	MIN	TYP ⁽²⁾	MAX	UNIT
Maximum data rate (see Figure 1)	R _L = 3 kΩ, One DOUT switching	C _L = 1000 pF		250	kbit/s
		C _L = 250 pF, V _{CC} = 3 V to 4.5 V		1000	
		C _L = 1000 pF, V _{CC} = 4.5 V to 5.5 V		1000	
t _{sk(p)}	Pulse skew ⁽³⁾ C _L = 150 pF to 2500 pF, R _L = 3 kΩ to 7 kΩ, See Figure 2		25		ns
SR(tr)	Slew rate, transition region (see Figure 1) C _L = 150 pF to 1000 pF, R _L = 3 kΩ to 7 kΩ, V _{CC} = 3.3 V		18	150	V/μs

- (1) Testing supply conditions are C1–C4 = 0.1 μF at V_{CC} = 3.3 V ± 0.15 V; C1–C4 = 0.22 μF at V_{CC} = 3.3 V ± 0.3 V; and C1 = 0.047 μF and C2–C4 = 0.33 μF at V_{CC} = 5 V ± 0.5 V.
- (2) All typical values are at V_{CC} = 3.3 V or V_{CC} = 5 V, and T_A = 25°C.
- (3) Pulse skew is defined as |t_{PLH} – t_{PHL}| of each channel of the same device.

ESD Protection

PARAMETER	TEST CONDITIONS	TYP	UNIT
DOUT	HBM	±15	kV
	IEC 61000-4-2, Air-Gap Discharge	±15	
	IEC 61000-4-2, Contact Discharge	±8	

PRODUCT PREVIEW

RECEIVER SECTION

Electrical Characteristics⁽¹⁾

over recommended ranges of supply voltage and operating free-air temperature (unless otherwise noted) (see [Figure 6](#))

PARAMETER		TEST CONDITIONS	MIN	TYP ⁽²⁾	MAX	UNIT
V _{OH}	High-level output voltage	I _{OH} = -1 mA	V _{CC} - 0.6	V _{CC} - 0.1		V
V _{OL}	Low-level output voltage	I _{OL} = 1.6 mA			0.4	V
V _{IT+}	Positive-going input threshold voltage	V _{CC} = 3.3 V		1.5	2.4	V
		V _{CC} = 5 V		1.8	2.4	
V _{IT-}	Negative-going input threshold voltage	V _{CC} = 3.3 V	0.6	1.2		V
		V _{CC} = 5 V	0.8	1.5		
V _{hys}	Input hysteresis (V _{IT+} - V _{IT-})			0.3		V
I _{OZ}	Output leakage current (except ROUT1B)	FORCEOFF = 0 V		±0.05	±10	µA
r _i	Input resistance	V _i = ±3 V to ±25 V	3	5	7	kΩ

(1) Testing supply conditions are C1–C4 = 0.1 µF at V_{CC} = 3.3 V ± 0.15 V; C1–C4 = 0.22 µF at V_{CC} = 3.3 V ± 0.3 V; and C1 = 0.047 µF and C2–C4 = 0.33 µF at V_{CC} = 5 V ± 0.5 V.

(2) All typical values are at V_{CC} = 3.3 V or V_{CC} = 5 V, and T_A = 25°C.

Switching Characteristics⁽¹⁾

over recommended ranges of supply voltage and operating free-air temperature (unless otherwise noted)

PARAMETER		TEST CONDITIONS	TYP ⁽²⁾	UNIT
t _{PLH}	Propagation delay time, low- to high-level output	C _L = 150 pF, See Figure 3	150	ns
t _{PHL}	Propagation delay time, high- to low-level output	C _L = 150 pF, See Figure 3	150	ns
t _{en}	Output enable time	C _L = 150 pF, R _L = 3 kΩ, See Figure 4	200	ns
t _{dis}	Output disable time	C _L = 150 pF, R _L = 3 kΩ, See Figure 4	200	ns
t _{sk(p)}	Pulse skew ⁽³⁾	See Figure 3	50	ns

(1) Testing supply conditions are C1–C4 = 0.1 µF at V_{CC} = 3.3 V ± 0.15 V; C1–C4 = 0.22 µF at V_{CC} = 3.3 V ± 0.3 V; and C1 = 0.047 µF and C2–C4 = 0.33 µF at V_{CC} = 5 V ± 0.5 V.

(2) All typical values are at V_{CC} = 3.3 V or V_{CC} = 5 V, and T_A = 25°C.

(3) Pulse skew is defined as |t_{PLH} - t_{PHL}| of each channel of the same device.

ESD Protection

PARAMETER	TEST CONDITIONS	TYP	UNIT
RIN	HBM	±15	kV
	IEC 61000-4-2, Air-Gap Discharge	±15	
	IEC 61000-4-2, Contact Discharge	±8	

SN65C3238E, SN75C3238E
3-V TO 5.5-V MULTICHANNEL RS-232 LINE DRIVERS/RECEIVERS
WITH ± 15 -kV ESD (HBM) PROTECTION

SLLS726–MAY 2006

AUTO-POWERDOWN PLUS SECTION

Electrical Characteristics

over recommended ranges of supply voltage and operating free-air temperature (unless otherwise noted) (see [Figure 5](#))

PARAMETER		TEST CONDITIONS	MIN	MAX	UNIT
$V_{T+(valid)}$	Receiver input threshold for $\overline{INVALID}$ high-level output voltage	FORCEON = GND, FORCEOFF = V_{CC}		2.7	V
$V_{T-(valid)}$	Receiver input threshold for $\overline{INVALID}$ high-level output voltage	FORCEON = GND, FORCEOFF = V_{CC}	-2.7		V
$V_{T(invalid)}$	Receiver input threshold for $\overline{INVALID}$ low-level output voltage	FORCEON = GND, FORCEOFF = V_{CC}	-0.3	0.3	V
V_{OH}	$\overline{INVALID}$ high-level output voltage	$I_{OH} = -1$ mA, FORCEON = GND, FORCEOFF = V_{CC}	$V_{CC} - 0.6$		V
V_{OL}	$\overline{INVALID}$ low-level output voltage	$I_{OL} = 1.6$ mA, FORCEON = GND, FORCEOFF = V_{CC}		0.4	V

Switching Characteristics

over recommended ranges of supply voltage and operating free-air temperature (unless otherwise noted) (see [Figure 5](#))

PARAMETER		MIN	TYP ⁽¹⁾	MAX	UNIT
t_{valid}	Propagation delay time, low- to high-level output		0.1		μ s
$t_{invalid}$	Propagation delay time, high- to low-level output		50		μ s
t_{en}	Supply enable time		25		μ s
t_{dis}	Receiver or driver edge to auto-powerdown plus	15	30	60	s

(1) All typical values are at $V_{CC} = 3.3$ V or $V_{CC} = 5$ V, and $T_A = 25^\circ\text{C}$.

PARAMETER MEASUREMENT INFORMATION

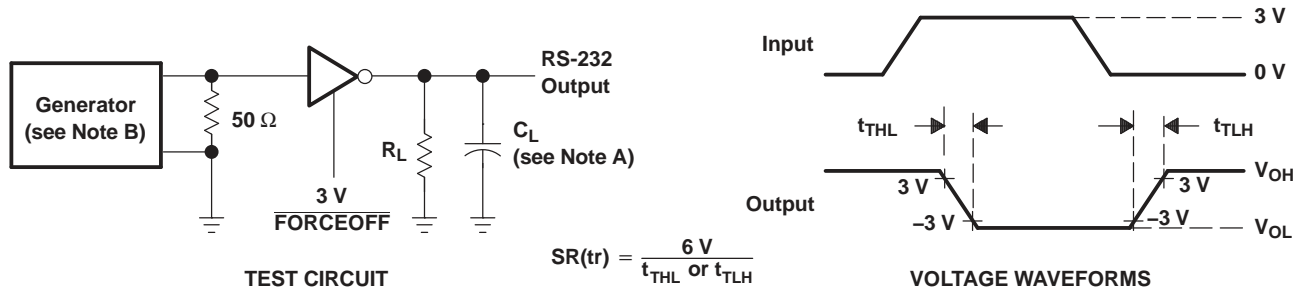

- A. C_L includes probe and jig capacitance.
- B. The pulse generator has the following characteristics: PRR = 250 kbit/s, $Z_O = 50 \Omega$, 50% duty cycle, $t_r \leq 10$ ns, $t_f \leq 10$ ns.

Figure 1. Driver Slew Rate

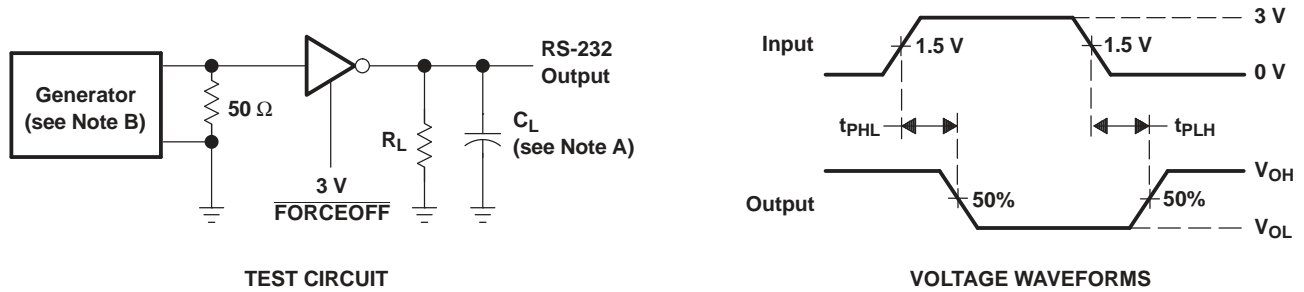

- A. C_L includes probe and jig capacitance.
- B. The pulse generator has the following characteristics: PRR = 250 kbit/s, $Z_O = 50 \Omega$, 50% duty cycle, $t_r \leq 10$ ns, $t_f \leq 10$ ns.

Figure 2. Driver Pulse Skew

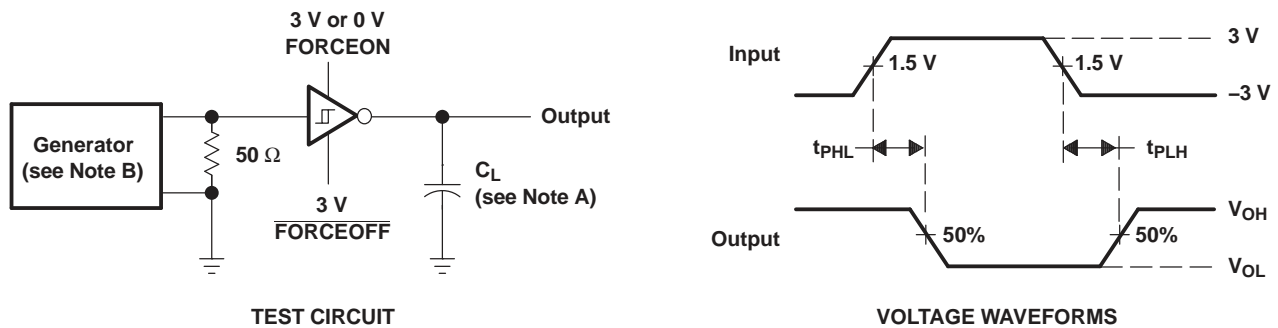

- A. C_L includes probe and jig capacitance.
- B. The pulse generator has the following characteristics: $Z_O = 50 \Omega$, 50% duty cycle, $t_r \leq 10$ ns, $t_f \leq 10$ ns.

Figure 3. Receiver Propagation Delay Times

PARAMETER MEASUREMENT INFORMATION (continued)

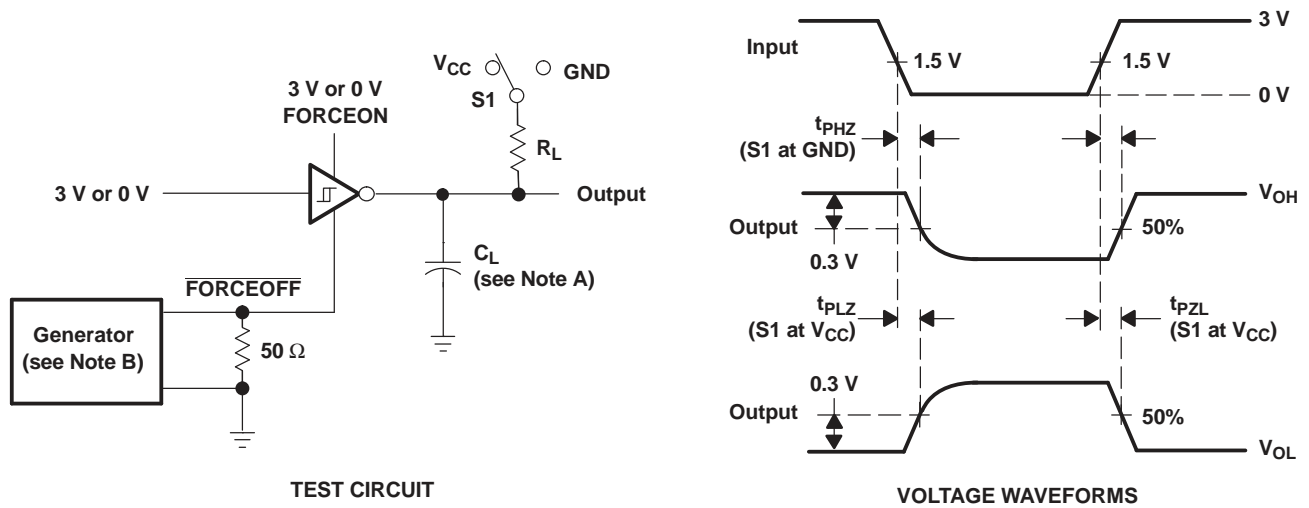

- A. C_L includes probe and jig capacitance.
- B. The pulse generator has the following characteristics: $Z_O = 50 \Omega$, 50% duty cycle, $t_r \leq 10$ ns, $t_f \leq 10$ ns.
- C. t_{PLZ} and t_{PHZ} are the same as t_{dis} .
- D. t_{PZL} and t_{PZH} are the same as t_{en} .

Figure 4. Receiver Enable and Disable Times

PARAMETER MEASUREMENT INFORMATION (continued)

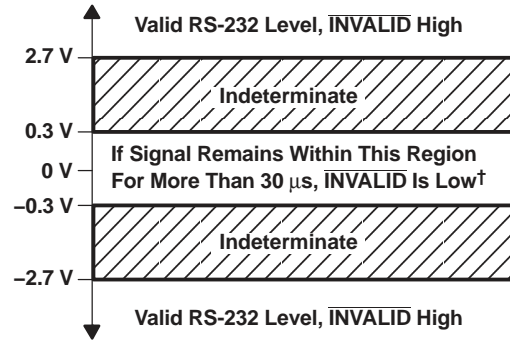
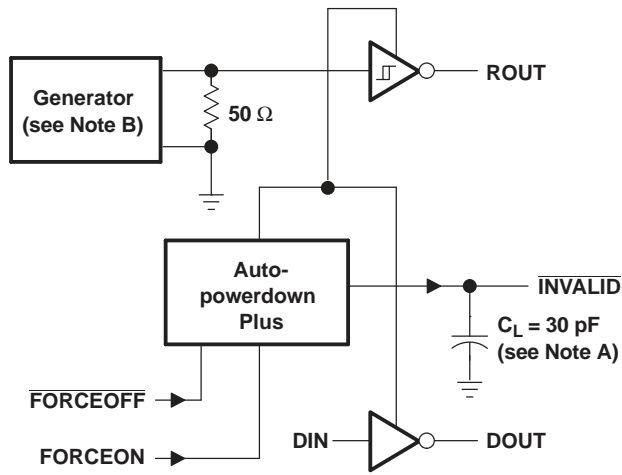

† Auto-powerdown plus disables drivers and reduces supply current to 1 μ A.

TEST CIRCUIT

- NOTES: A. C_L includes probe and jig capacitance.
B. The pulse generator has the following characteristics: PRR = 5 kbit/s, $Z_O = 50 \Omega$, 50% duty cycle, $t_r \leq 10$ ns, $t_f \leq 10$ ns.

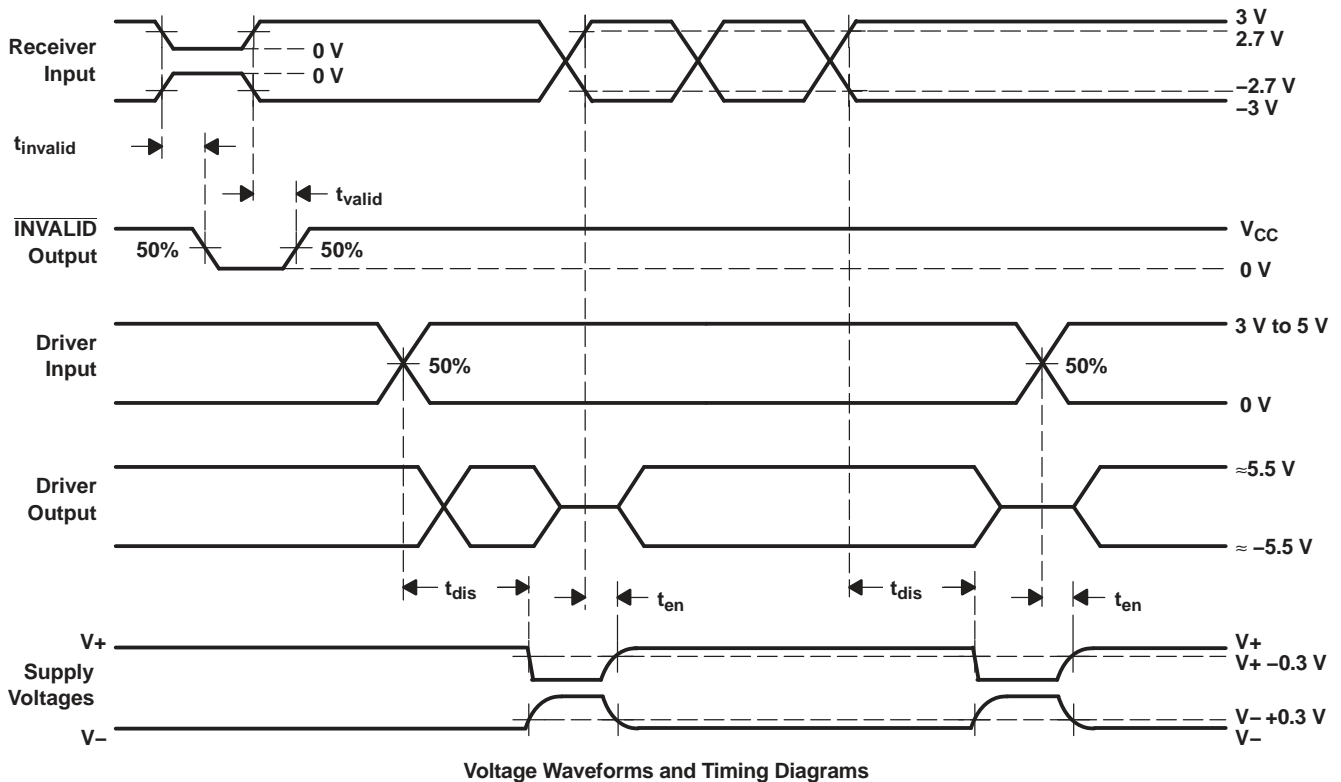
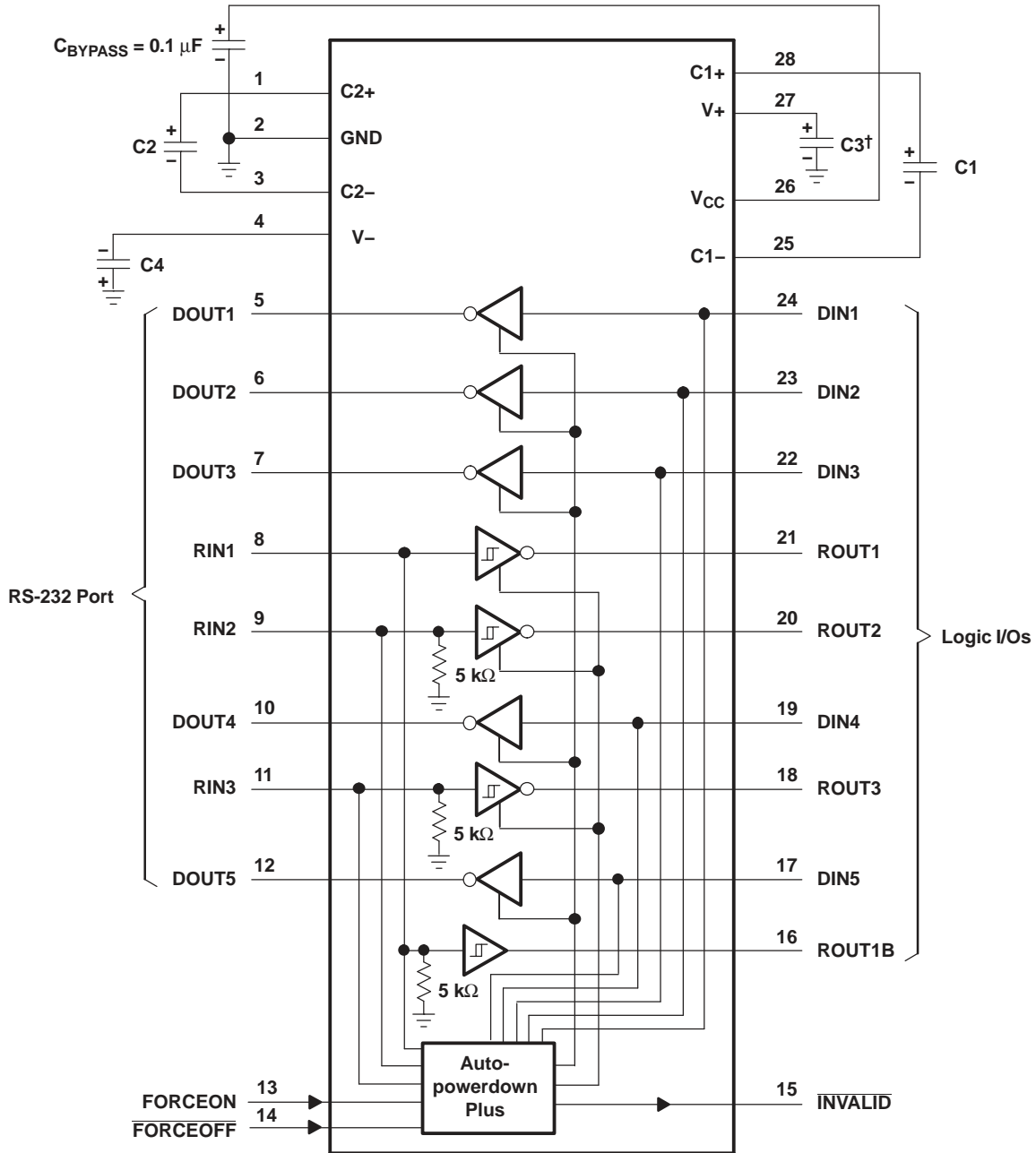

Figure 5. $\overline{\text{INVALID}}$ Propagation-Delay Times and Supply-Enabling Time

PRODUCT PREVIEW

APPLICATION INFORMATION



V_{CC} vs CAPACITOR VALUES

V _{CC}	C1	C2, C3, and C4
3.3 V ± 0.15 V	0.1 μF	0.1 μF
3.3 V ± 0.3 V	0.22 μF	0.22 μF
5 V ± 0.5 V	0.047 μF	0.33 μF
3 V to 5.5 V	0.22 μF	1 μF

† C3 can be connected to V_{CC} or GND.

NOTES: A. Resistor values shown are nominal.

B. Nonpolarized ceramic capacitors are acceptable. If polarized tantalum or electrolytic capacitors are used, they should be connected as shown.

Figure 6. Typical Operating Circuit and Capacitor Values

PRODUCT PREVIEW

TAPE AND REEL INFORMATION

QUADRANT ASSIGNMENTS FOR PIN 1 ORIENTATION IN TAPE

*All dimensions are nominal

Device	Package Type	Package Drawing	Pins	SPQ	Reel Diameter (mm)	Reel Width W1 (mm)	A0 (mm)	B0 (mm)	K0 (mm)	P1 (mm)	W (mm)	Pin1 Quadrant
SN65C3238EDBR	SSOP	DB	28	2000	330.0	16.4	8.2	10.5	2.5	12.0	16.0	Q1
SN65C3238EDWR	SOIC	DW	28	1000	330.0	32.4	11.35	18.67	3.1	16.0	32.0	Q1
SN75C3238EDBR	SSOP	DB	28	2000	330.0	16.4	8.2	10.5	2.5	12.0	16.0	Q1
SN75C3238EDWR	SOIC	DW	28	1000	330.0	32.4	11.35	18.67	3.1	16.0	32.0	Q1

TAPE AND REEL BOX DIMENSIONS



*All dimensions are nominal

Device	Package Type	Package Drawing	Pins	SPQ	Length (mm)	Width (mm)	Height (mm)
SN65C3238EDBR	SSOP	DB	28	2000	356.0	356.0	35.0
SN65C3238EDWR	SOIC	DW	28	1000	350.0	350.0	66.0
SN75C3238EDBR	SSOP	DB	28	2000	356.0	356.0	35.0
SN75C3238EDWR	SOIC	DW	28	1000	350.0	350.0	66.0

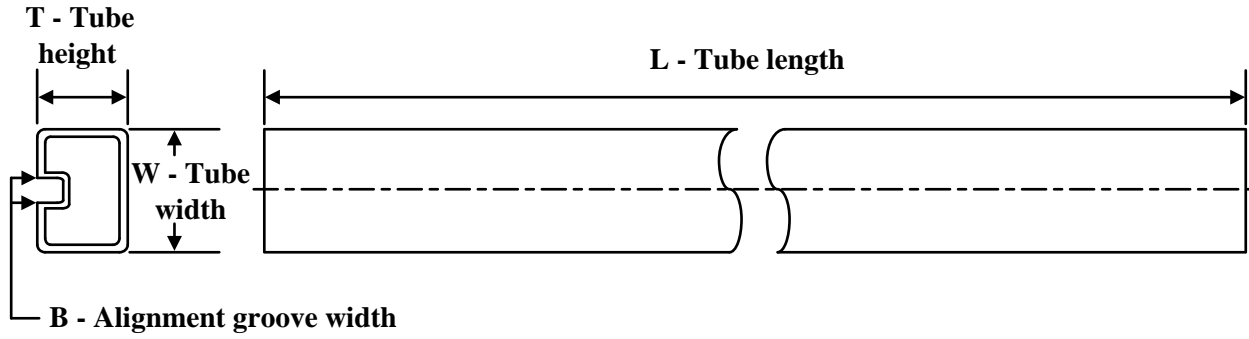
TUBE

*All dimensions are nominal

Device	Package Name	Package Type	Pins	SPQ	L (mm)	W (mm)	T (μm)	B (mm)
SN65C3238EDB	DB	SSOP	28	50	530	10.5	4000	4.1
SN75C3238EDB	DB	SSOP	28	50	530	10.5	4000	4.1

DB0028A



PACKAGE OUTLINE

SSOP - 2 mm max height

SMALL OUTLINE PACKAGE

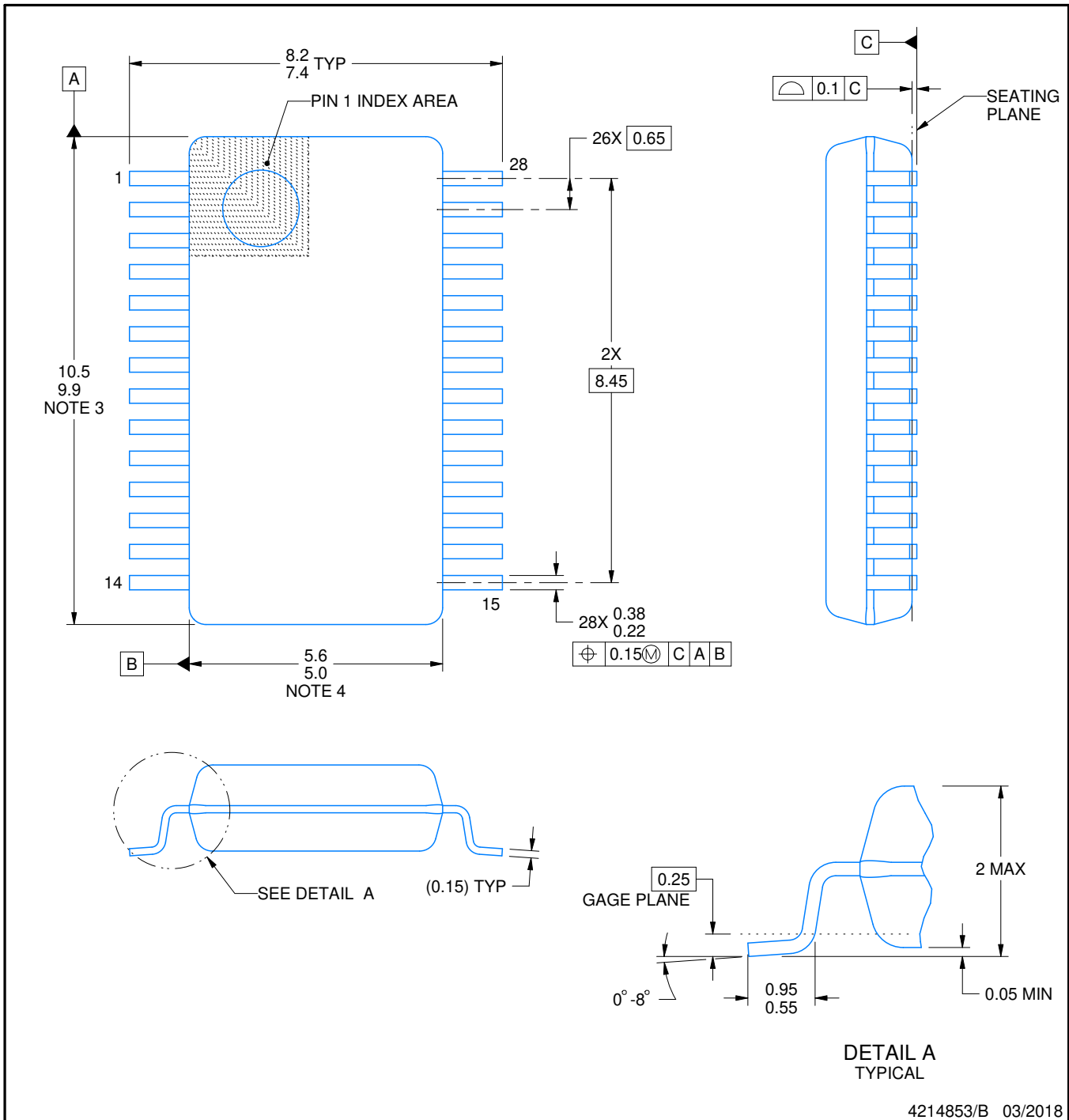

4214853/B 03/2018

NOTES:

1. All linear dimensions are in millimeters. Any dimensions in parenthesis are for reference only. Dimensioning and tolerancing per ASME Y14.5M.
2. This drawing is subject to change without notice.
3. This dimension does not include mold flash, protrusions, or gate burrs. Mold flash, protrusions, or gate burrs shall not exceed 0.15 mm per side.
4. This dimension does not include interlead flash. Interlead flash shall not exceed 0.25 mm per side.
5. Reference JEDEC registration MO-150.

EXAMPLE BOARD LAYOUT

DB0028A

SSOP - 2 mm max height

SMALL OUTLINE PACKAGE

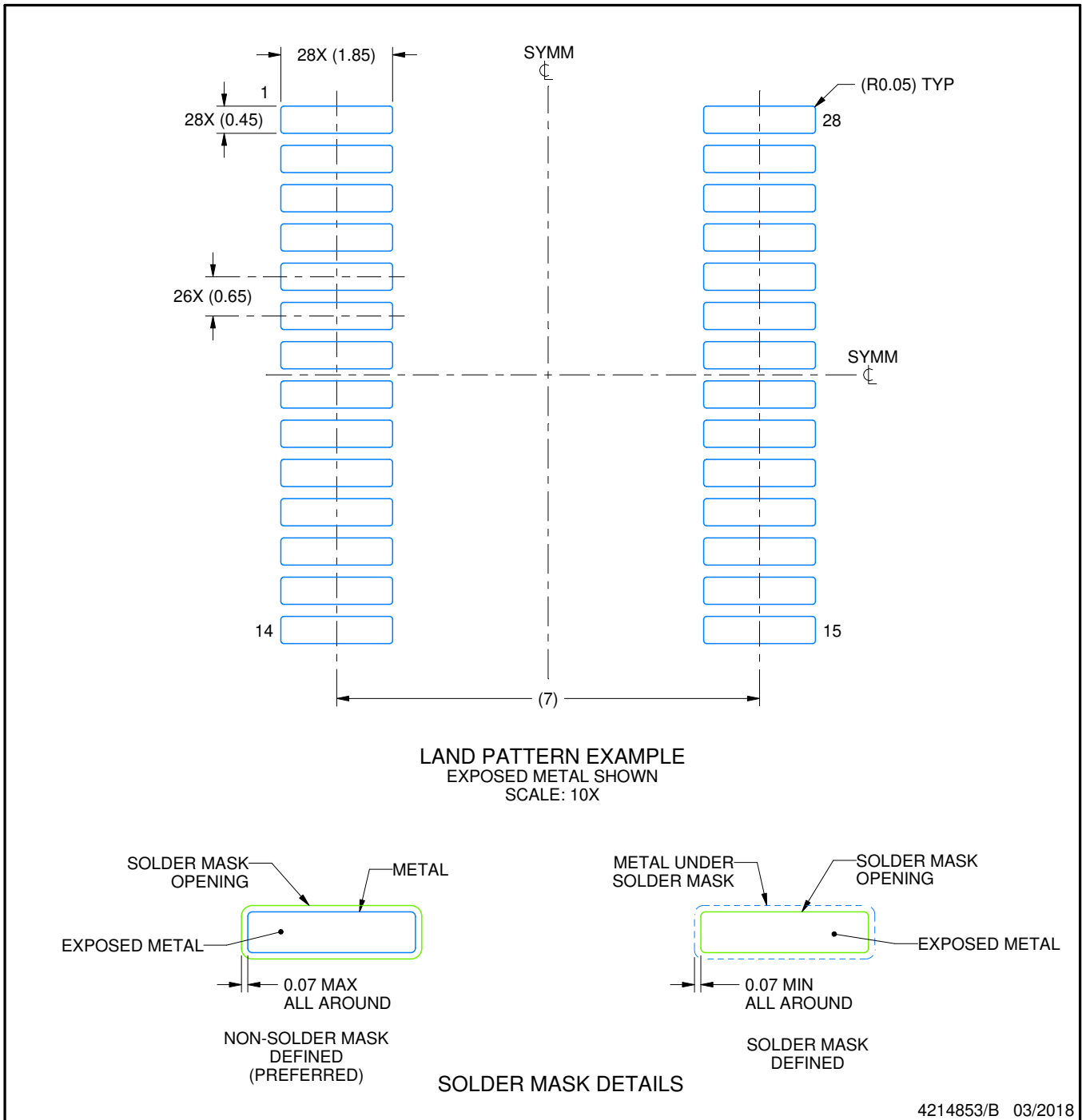

NOTES: (continued)

6. Publication IPC-7351 may have alternate designs.
7. Solder mask tolerances between and around signal pads can vary based on board fabrication site.

EXAMPLE STENCIL DESIGN

DB0028A

SSOP - 2 mm max height

SMALL OUTLINE PACKAGE

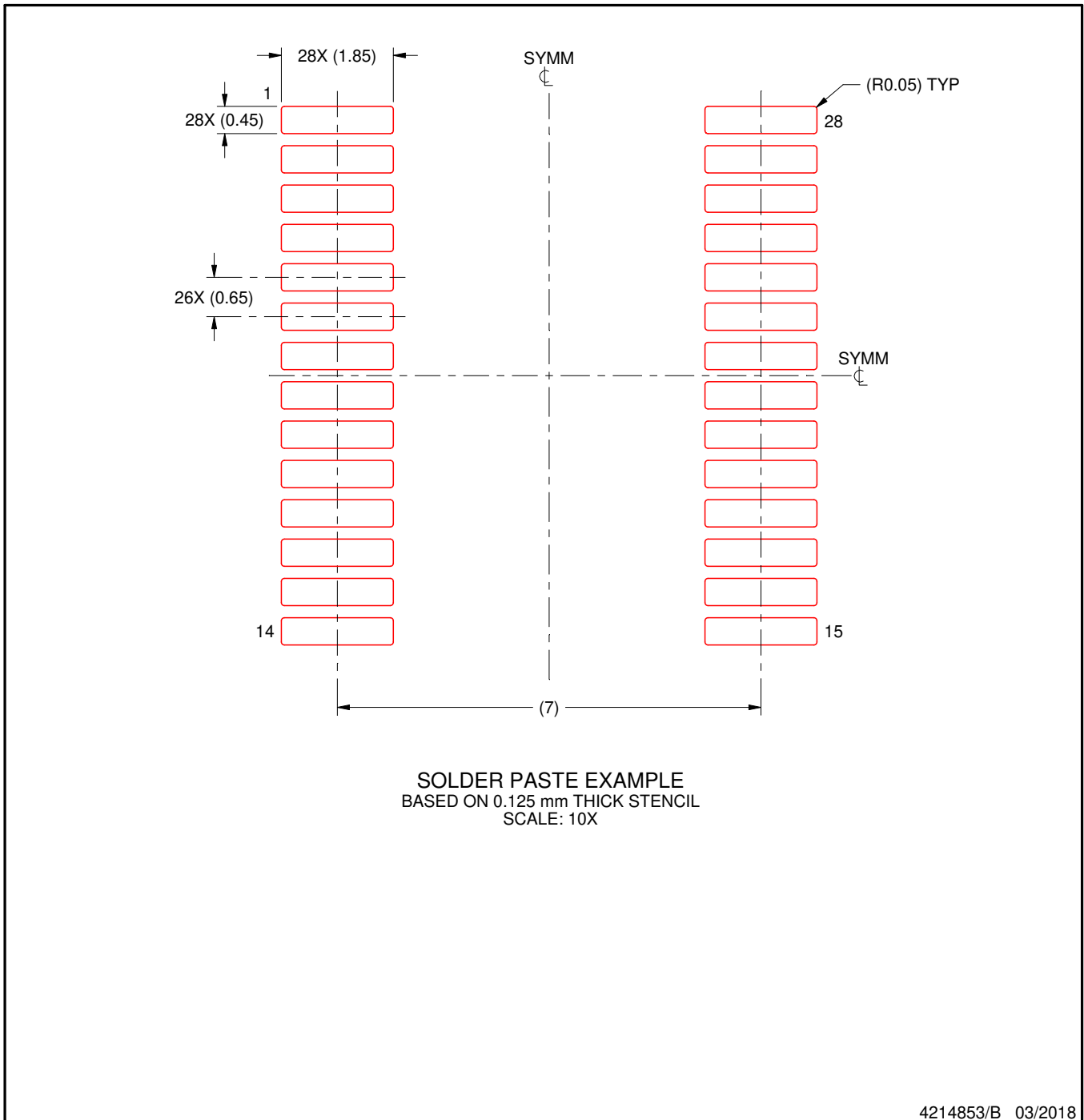

NOTES: (continued)

8. Laser cutting apertures with trapezoidal walls and rounded corners may offer better paste release. IPC-7525 may have alternate design recommendations.
9. Board assembly site may have different recommendations for stencil design.

DW (R-PDSO-G28)

PLASTIC SMALL OUTLINE

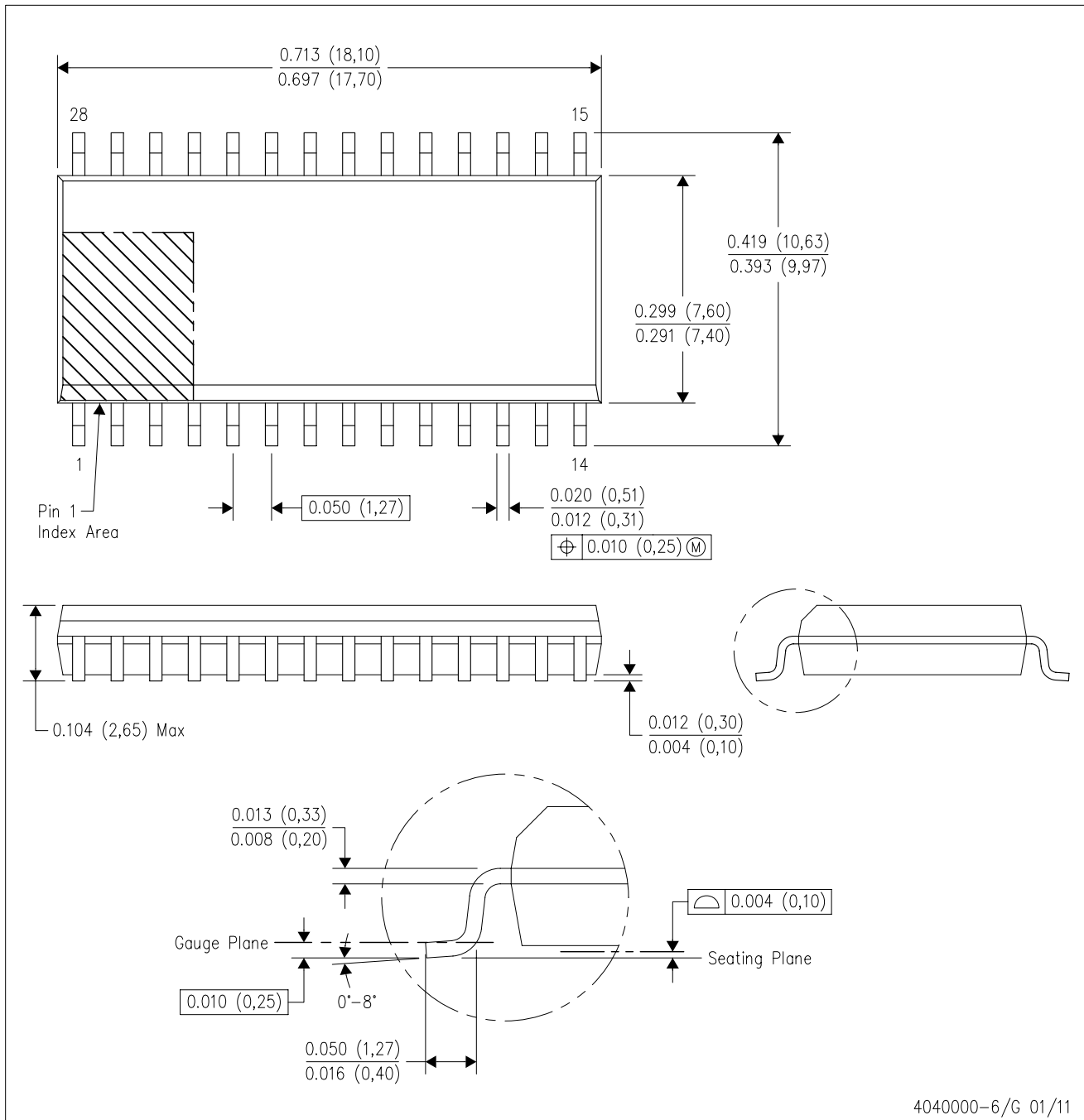

- NOTES:
- All linear dimensions are in inches (millimeters). Dimensioning and tolerancing per ASME Y14.5M-1994.
 - This drawing is subject to change without notice.
 - Body dimensions do not include mold flash or protrusion not to exceed 0.006 (0,15).
 - Falls within JEDEC MS-013 variation AE.

DW (R-PDSO-G28)

PLASTIC SMALL OUTLINE

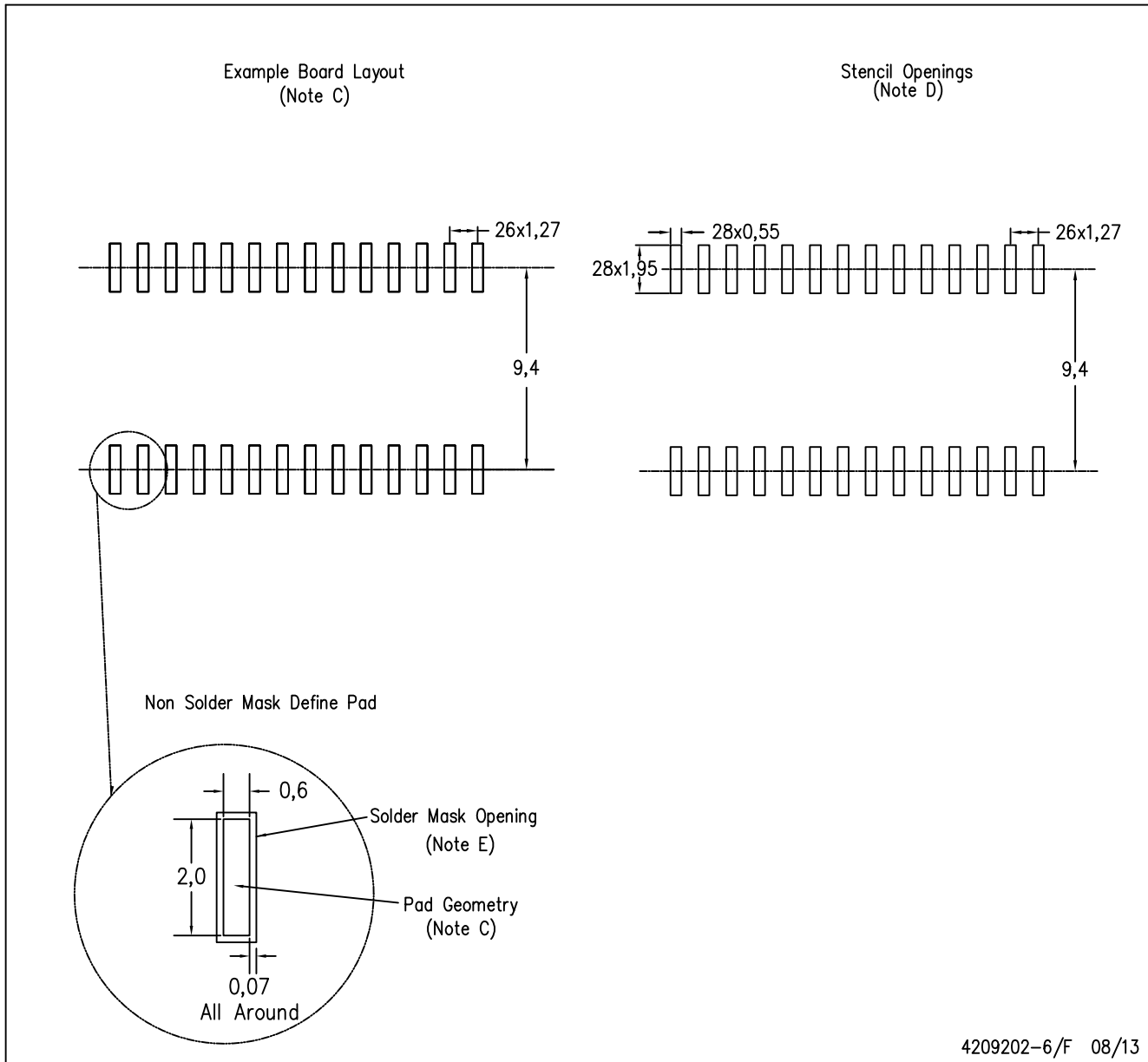

4209202-6/F 08/13

- NOTES:
- A. All linear dimensions are in millimeters.
 - B. This drawing is subject to change without notice.
 - C. Refer to IPC7351 for alternate board design.
 - D. Laser cutting apertures with trapezoidal walls and also rounding corners will offer better paste release. Customers should contact their board assembly site for stencil design recommendations. Refer to IPC-7525
 - E. Customers should contact their board fabrication site for solder mask tolerances between and around signal pads.

IMPORTANT NOTICE AND DISCLAIMER

TI PROVIDES TECHNICAL AND RELIABILITY DATA (INCLUDING DATA SHEETS), DESIGN RESOURCES (INCLUDING REFERENCE DESIGNS), APPLICATION OR OTHER DESIGN ADVICE, WEB TOOLS, SAFETY INFORMATION, AND OTHER RESOURCES "AS IS" AND WITH ALL FAULTS, AND DISCLAIMS ALL WARRANTIES, EXPRESS AND IMPLIED, INCLUDING WITHOUT LIMITATION ANY IMPLIED WARRANTIES OF MERCHANTABILITY, FITNESS FOR A PARTICULAR PURPOSE OR NON-INFRINGEMENT OF THIRD PARTY INTELLECTUAL PROPERTY RIGHTS.

These resources are intended for skilled developers designing with TI products. You are solely responsible for (1) selecting the appropriate TI products for your application, (2) designing, validating and testing your application, and (3) ensuring your application meets applicable standards, and any other safety, security, regulatory or other requirements.

These resources are subject to change without notice. TI grants you permission to use these resources only for development of an application that uses the TI products described in the resource. Other reproduction and display of these resources is prohibited. No license is granted to any other TI intellectual property right or to any third party intellectual property right. TI disclaims responsibility for, and you will fully indemnify TI and its representatives against, any claims, damages, costs, losses, and liabilities arising out of your use of these resources.

TI's products are provided subject to [TI's Terms of Sale](#) or other applicable terms available either on ti.com or provided in conjunction with such TI products. TI's provision of these resources does not expand or otherwise alter TI's applicable warranties or warranty disclaimers for TI products.

TI objects to and rejects any additional or different terms you may have proposed.

Mailing Address: Texas Instruments, Post Office Box 655303, Dallas, Texas 75265
Copyright © 2022, Texas Instruments Incorporated