

Features

- Enables Atmel Legacy platforms to use newer ZigBit[®] Extensions.
- Supports RF-only ZigBits, SoC ZigBits and RF Extensions.
- On board current measurement header.
- Minimal jumper configuration.

Table of Contents

1. Introduction	3
1.1 Summary.....	3
1.2 Supported kits containing 10 pin Headers.....	3
2. Specifications.....	3
2.1 Pin Configuration.....	3
2.2 Jumper Settings	4
2.3 Current Measurement	5
2.4 Schematics	5
3. Revision History	6

1. Introduction

1.1 Summary

ATXPRO-10PIN is a 10- to 20-pin adaptor that facilitates to connect new 20-pin Zigbits extensions and RF extensions to legacy 10-pin headers on SAM-EKs, STK[®]600, Xplained kits. The 10-pin header on legacy kits refers to the RF header where RZ600 fits. The supported 20-pin extensions includes RF only ZigBit extension, SoC ZigBit extension and REB233-XPRO.

1.2 Supported Kits Containing 10 Pin Headers

- | | | | |
|-------------|--------------|-------------------------------------|------------------------|
| 1. SAM4E-EK | 4. SAM4L-EK | 7. XMEGA [®] A3BU Xplained | 10. SAM4S-XPLD |
| 2. SAM3X-EK | 5. SAM4S-EK2 | 8. XMEGA B1 Xplained | 11. Mega1284P Xplained |
| 3. SAM3S-EK | 6. SAM3N-EK | 9. XMEGA A1 Xplained | 12. STK600 |

2. Specifications

2.1 Pin Configuration

Pin No.	20-pin Connector (J3)
1	ID_DATA
2	GND
3	ADC(+)
4	ADC(-)
5	GPIO
6	GPIO
7	PWM(+)
8	PWM(-)
9	IRQ/GPIO
10	SPI_SS_B/GPIO
11	TWI_SDA
12	TWI_SCL
13	UART_RX
14	UART_TX
15	SPI_SS_A
16	SPI_MOSI
17	SPI_MISO
18	SPI_SCK
19	GND
20	VCC_TARGET

Pin No.	10-pin Connector (J1)
1	RST
2	MISC IO
3	IRQ
4	SLP_TR
5	SEL/SPI_CS
6	MOSI
7	MISO
8	SCLK/SPCK
9	GND
10	VCC

Note: Refer datasheets of the selected evaluation board or XPRO extension for details on the signal names mentioned in above tables.

2.2 Jumper Settings

For REB233-XPRO and RF only Zigbits, jumper settings for J4 and J2 are as shown in [Figure 2-1](#).

Figure 2-1. ATXPRO-10PIN for REB233-XPRO and RF only ZigBits

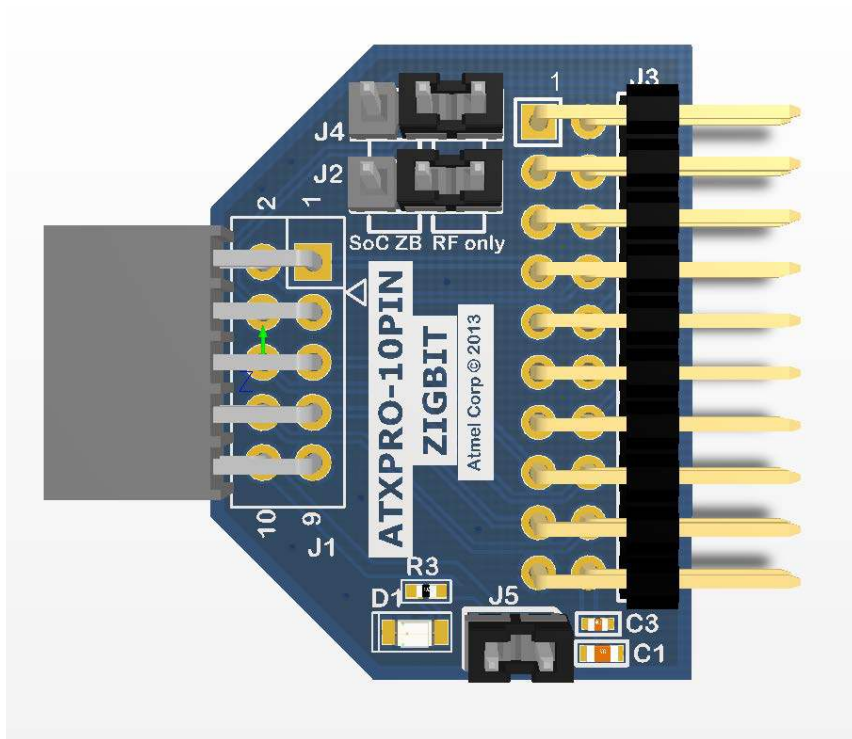

For SoC Zigbits, jumper settings for J4 and J2 are as shown in [Figure 2-2](#).

Figure 2-2. ATXPRO-10PIN for SoC ZigBits

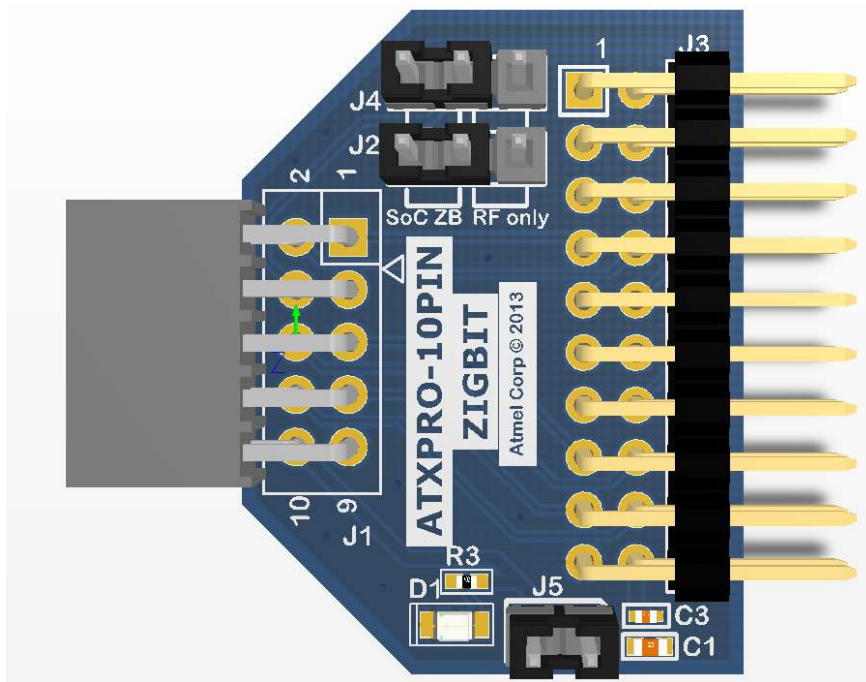

2.3 Current Measurement

Header J5 is the current measurement header which enables user to measure current consumed by the extension modules. When 'J5' is not used for current measurement, the jumper should be placed on it.

2.4 Schematics

The schematic of the 10-pin to 20-pin Adaptor is shown below.

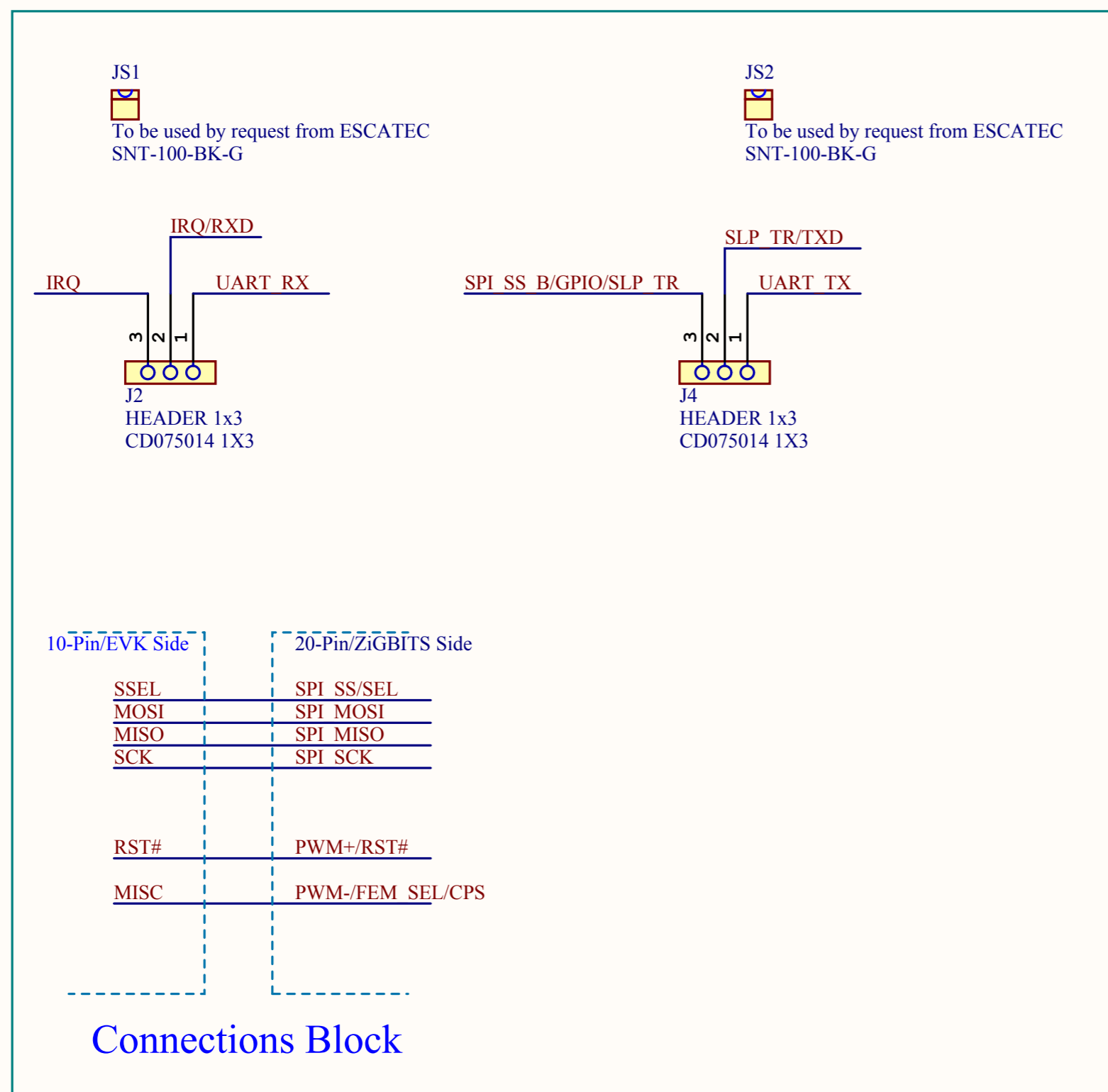

Note:
 For some of these kits pin3 and pin4 of 10pin Connector has UART interface connected.
 for those kits SoCZigbits Can be directly interfaced.
 1.Xmega A3BU Xplained
 2.Xmega B1 Xplained
 3.Xmega A1 Xplained
 4.SAM4S-XPLD
 5.Mega1284P Xplained
 6.STK600(mapping)

Note:
 1. ID_DATA has no connection to 10-pin Connector
 2. ADC+/NC/DIG1, ADC-/DIG2, TWI_SDA, TWI_SCL, UART_RX and UART_TX have no connection to 10-pin connector, except(UART_RX and UART_TX were used for some kits)
 3. CSD has Pull down on RF-only Zigbits.

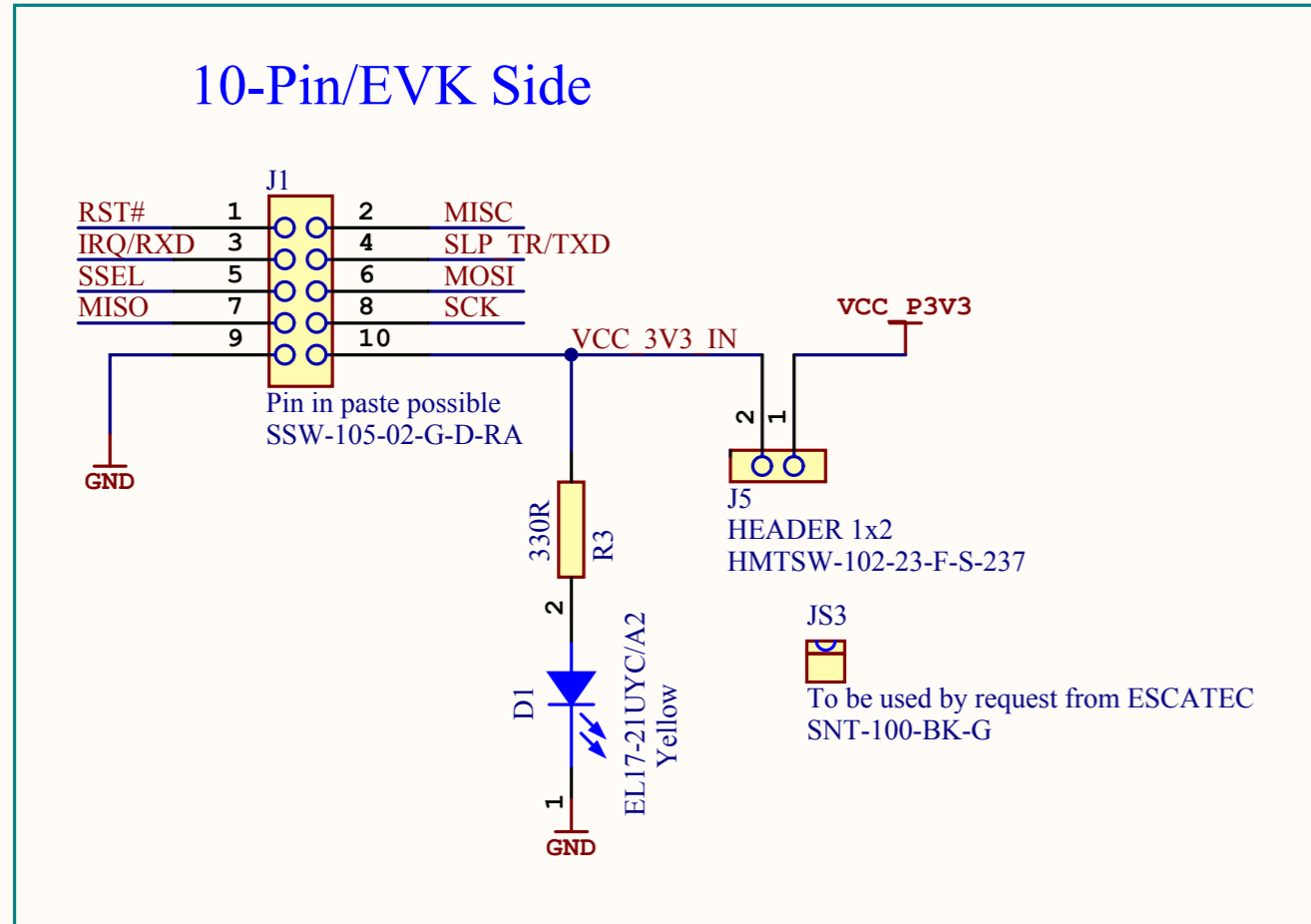
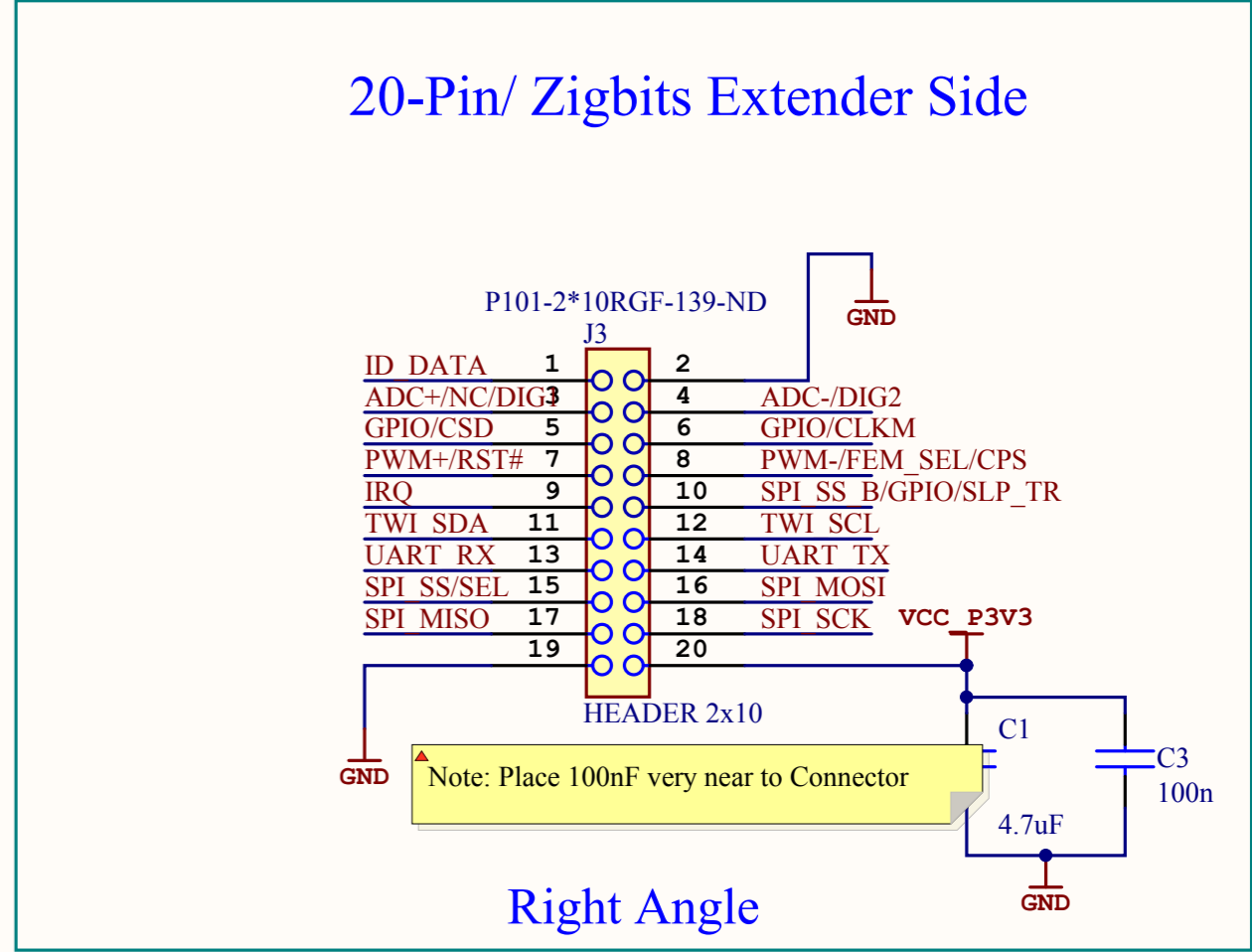

Supported Zigbits
 1. RF212B RF-only Zigbits
 2. RF233 RF-only Zigbits
 3. mega256RFR2 SoC Zigbits(Optional - only listed kits will be supported)

Note:
 As this is an adapto doesn't require Rubber Feet

ATMEL R&D INDIA	Mallikarjun	
RMZ Millenia	Narayana Karthik	
Chennai	*	
INDIA		
Date:	7/16/2013 1:59:52 PM	PAGE: 1 of 1
Document number:	*	Revision 1
TITLE: 10-pin to 20-pin XPRO adaptor		
ATXPRO-10PIN.SchDoc		

3. Revision History

Doc. Rev.	Date	Comments
42207A	10/2013	Initial document release

**Atmel Corporation**

1600 Technology Drive
San Jose, CA 95110
USA

Tel: (+1)(408) 441-0311

Fax: (+1)(408) 487-2600

www.atmel.com

Atmel Asia Limited

Unit 01-5 & 16, 19F
BEA Tower, Millennium City 5
418 Kwun Tong Road

Kwun Tong, Kowloon

HONG KONG

Tel: (+852) 2245-6100

Fax: (+852) 2722-1369

Atmel Munich GmbH

Business Campus
Parkring 4
D-85748 Garching b. Munich

GERMANY

Tel: (+49) 89-31970-0

Fax: (+49) 89-3194621

Atmel Japan G.K.

16F Shin-Osaki Kangyo Bldg.
1-6-4 Osaki, Shinagawa-ku
Tokyo 141-0032

JAPAN

Tel: (+81)(3) 6417-0300

Fax: (+81)(3) 6417-0370

© 2013 Atmel Corporation. All rights reserved. / Rev.: 42207A-WIRELESS-10/2013

Atmel®, Atmel logo and combinations thereof, Enabling Unlimited Possibilities®, STK®, XMEGA®, ZigBit® and others are registered trademarks or trademarks of Atmel Corporation or its subsidiaries. Other terms and product names may be trademarks of others.

Disclaimer: The information in this document is provided in connection with Atmel products. No license, express or implied, by estoppel or otherwise, to any intellectual property right is granted by this document or in connection with the sale of Atmel products. EXCEPT AS SET FORTH IN THE ATMEL TERMS AND CONDITIONS OF SALES LOCATED ON THE ATMEL WEBSITE, ATMEL ASSUMES NO LIABILITY WHATSOEVER AND DISCLAIMS ANY EXPRESS, IMPLIED OR STATUTORY WARRANTY RELATING TO ITS PRODUCTS INCLUDING, BUT NOT LIMITED TO, THE IMPLIED WARRANTY OF MERCHANTABILITY, FITNESS FOR A PARTICULAR PURPOSE, OR NON-INFRINGEMENT. IN NO EVENT SHALL ATMEL BE LIABLE FOR ANY DIRECT, INDIRECT, CONSEQUENTIAL, PUNITIVE, SPECIAL OR INCIDENTAL DAMAGES (INCLUDING, WITHOUT LIMITATION, DAMAGES FOR LOSS AND PROFITS, BUSINESS INTERRUPTION, OR LOSS OF INFORMATION) ARISING OUT OF THE USE OR INABILITY TO USE THIS DOCUMENT, EVEN IF ATMEL HAS BEEN ADVISED OF THE POSSIBILITY OF SUCH DAMAGES. Atmel makes no representations or warranties with respect to the accuracy or completeness of the contents of this document and reserves the right to make changes to specifications and products descriptions at any time without notice. Atmel does not make any commitment to update the information contained herein. Unless specifically provided otherwise, Atmel products are not suitable for, and shall not be used in, automotive applications. Atmel products are not intended, authorized, or warranted for use as components in applications intended to support or sustain life.