

PART NUMBER	REV	FIRST USED
680732-1	B	122500-1
680732-2	B	565435-5
680732-3	B	354500-1

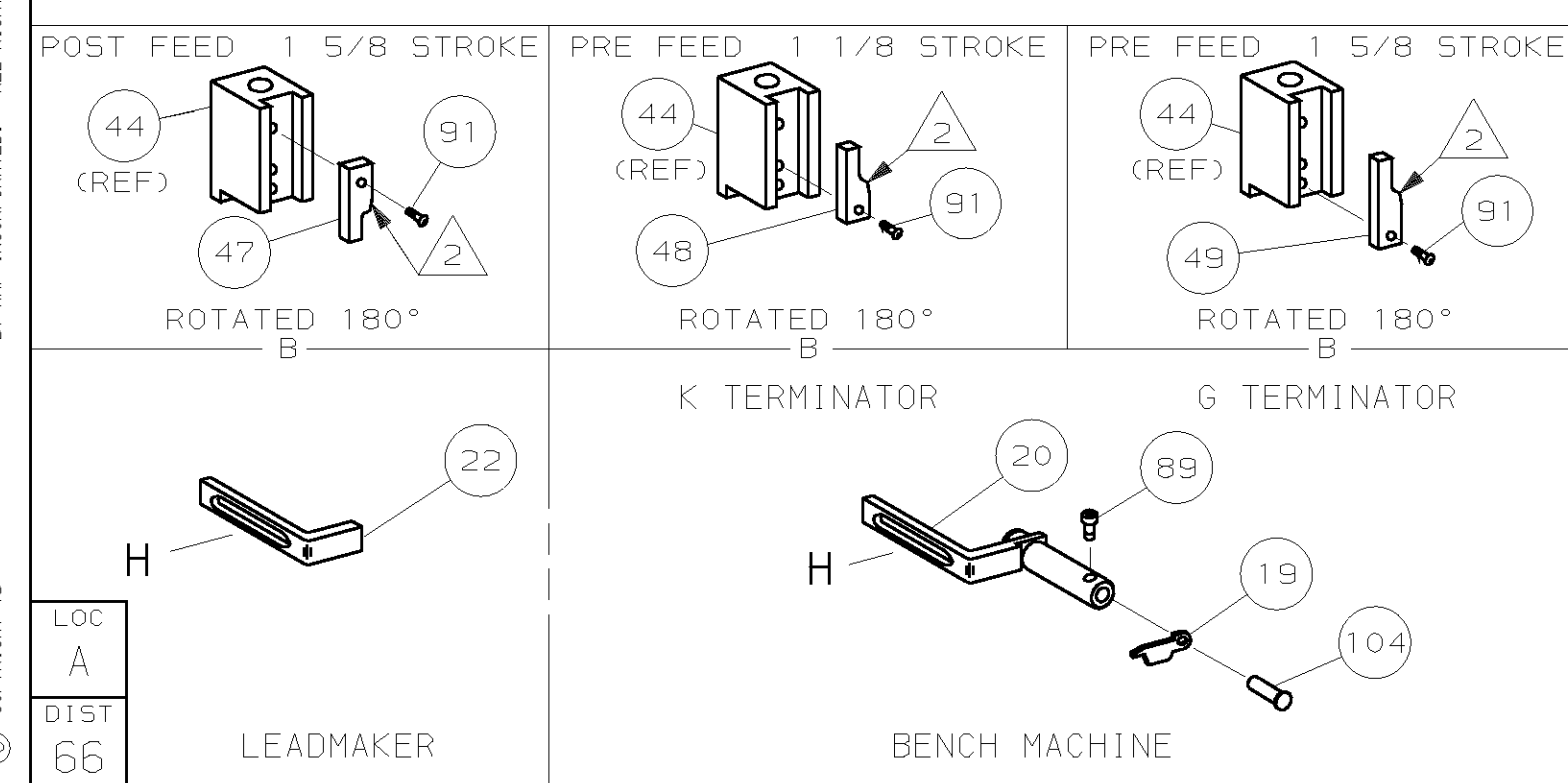
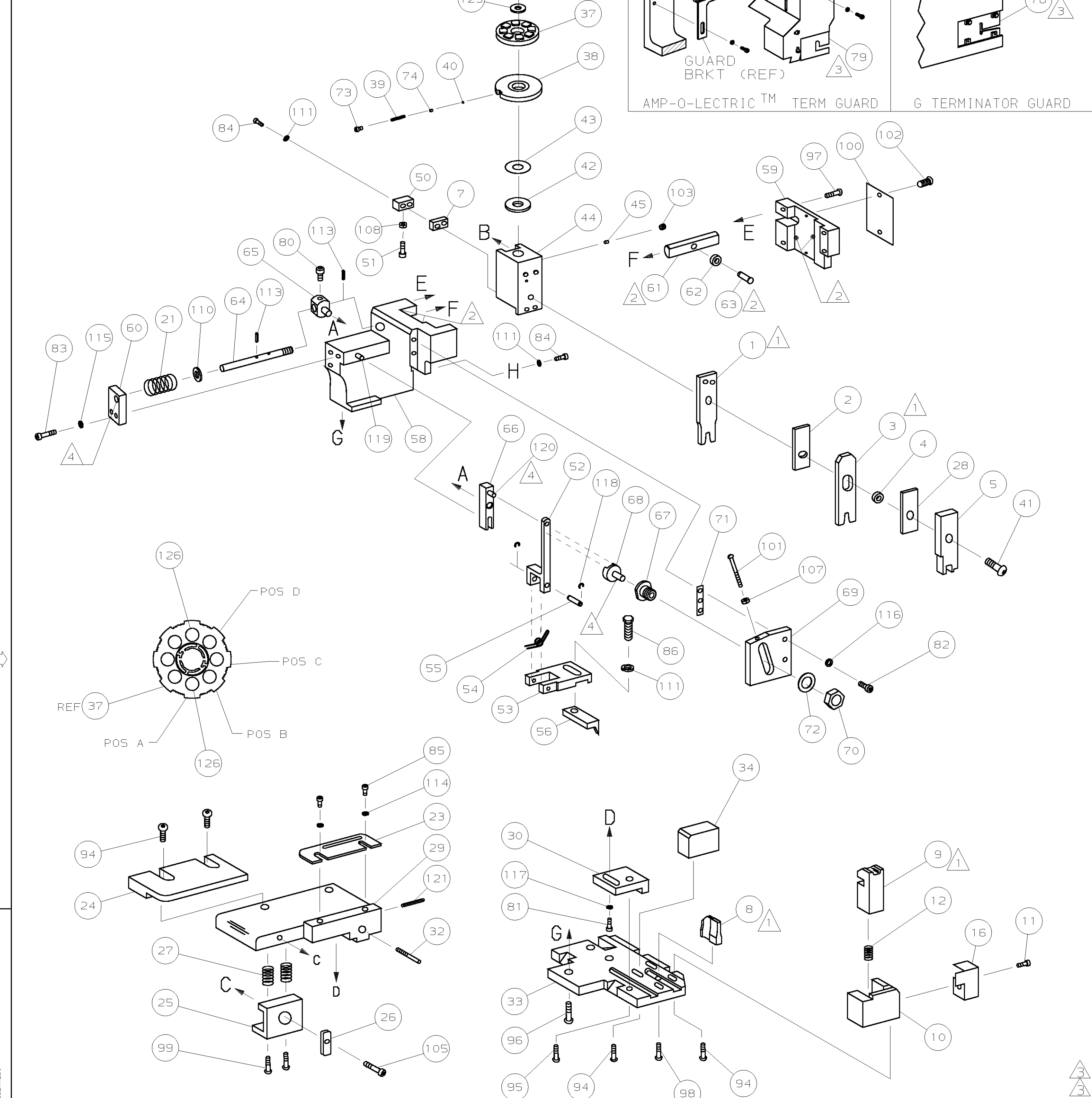

- 1 RECOMMENDED SPARE PARTS.
- 2 GREASE LIGHTLY.
- 3 GUARD MUST BE IN PLACE WHEN OPERATING APPLICATOR IN A BENCH MACHINE.
- 4 LUBRICATE DAILY USING NO. 20 MACHINE OIL.
- 5. ITEMS WITH QTY OF REF SPECIFIED (EXCEPT ITEMS 78 AND 79) ARE USED ON ITEM 46.

AMP P/N		MFG P/N		CRIMP DATA (NON-AMP TERMINAL-AMP SPEC)		
286767		471410	GJ02	PAD LTR	CRIMP HEIGHT	WIRE SIZE
286769		451411	GJ02	A	.068 ±.002 [1.72 ±0.05mm]	16
				B	NOT	USED
				C	NOT	USED
				D	NOT	USED
				CRIMP SIZE TYPE RANGE		
				WIRE	.080 [2.03mm]	F 16
				INSUL	.130 [3.30mm]	F ϕ.130 MAX
WIRE STRIP LENGTH .188-.219		TERM APPL SPEC NONE		FEED .522		APPL INSTRUCTION 408-8040
				SET UP GAGE 458637-1		LAYOUT L2156

QTY	REF	P/N	DESCRIPTION	ITEM NO
1	1	1		129
2	2	2		128
1	1	1	8-354778-9 PIN, WIRE DISC (.2940)A	126
1	1	1	986950-1 WASHER, FLAT PRECISION	125
1	1	1	217238-1 GENERAL INSTRUCTION PACKAGE	124
1	1	1	4088040 SF APPL INST 408-8040	123
				122
1	1	1	4-21028-0 PIN, SLT SPR (ϕ.093x.75) ST GDE PL	121
REF	REF	REF	1-21030-1 PIN, DOWEL (ϕ.187x.50) LEVER	120
REF	REF	REF	1-21030-6 PIN, DOWEL (ϕ.187x1.25) HOUSING	119
REF	REF	REF	21045-3 RING, RET "C" (ϕ.187) FD FING PIN	118
1	1	1	21024-5 WASHER, LOCK (#10) ADJ BLOCK	117
REF	REF	REF	21024-5 WASHER, LOCK (#10) ADJ PLATE	116
REF	REF	REF	21024-5 WASHER, LOCK (#10) FEED GDE ROD	115
2	2	2	21024-2 WASHER, LOCK (#4) FRONT STP GUIDE	114
REF	REF	REF	5-21028-1 PIN, SLT SPR (ϕ.125x.50) ADJ ROD	113
				112
4	4	4	21024-4 WASHER, LOCK (#8) STRIPPER	111
REF	REF	REF	21899-4 WASHER, FLAT (ϕ5/16) SCREW ADJ	110
				109
1	1	1	21018-5 NUT, HEX (NO. 6) HOLDDOWN	108
REF	REF	REF	21068-5 NUT, HEX (6-32) FEED ADJ	107
				106
1	1	1	22353-8 SCR, SHLD (ϕ.187x.25) DRAG LEVER	105
1	1	-	992031-1 PIN, CLEVIS	104
1	1	1	21009-2 SCR, SKT SET (1/4-20x.25 LW) RAM	103
2	2	2	21017-2 SCR, DRIVE (#2x.19) ID PLATE	102
REF	REF	REF	6-23715-5 SCR, PAN HD (6-32x1.50) FEED ADJ	101
1	1	1	461264-1 PLATE, IDENTIFICATION	100
2	2	2	3-21002-0 SCR, BHC (10-32x.88) DRAG	99
1	1	1	22733-8 SCR, BHC (8-32x.38 LW) ANVIL	98
REF	REF	REF	2-21002-9 SCR, BHC (10-32x.75) CAP	97
REF	REF	REF	2-22733-8 SCR, BHC (1/4-20x.62) HOUSING	96
REF	REF	REF	2-21002-7 SCR, BHC (10-32x.50) SG ADJ BLOCK	95
6	6	6	2-21002-2 SCR, BHC (8-32x.50) TERM H DWN	94
				93
				92
				91
1	1	1	1-21002-7 SCR, BHC (6-32x.38) CAM	90
				89
				88
				87
1	1	1	2-22603-0 SCR, HEX HD (8-32x.31) FEED FINGER	86
2	2	2	1-21000-3 SCR, SHC (4-40x.25) F ST GUIDE	85
3	3	3	2-21000-7 SCR, SHC (8-32x.50) STRIPPER	84
REF	REF	REF	3-21000-7 SCR, SHC (10-32x.75) FEED ROD GD	83
REF	REF	REF	3-21000-6 SCR, SHC (10-32x.62) FD ADJ BLK	82
1	1	1	3-21000-4 SCR, SHC (10-32x.38) SG ADJ BL	81
REF	REF	REF	3-21000-4 SCR, SHC (10-32x.38) PIVOT BLK	80
-	REF	-	455749-1 GUARD, WINDOW	79
REF	-	-	679532-1 INSERT, GUARD	78
				77
				76
				75
1	1	1	690603-1 SPRING, ASSIST	74
1	1	1	23030-1 SCR, SHC (6-32x.25 SL) INS DISC	73
REF	REF	REF	458109-1 WASHER, SPECIAL	72
REF	REF	REF	690517-1 SPACER	71
				70
				69
				68
				67
				66
				65
				64
				63
				62
				61
				60
				59
				58
				57
				56
				55
				54
				53
				52
				51
				50
				49
				48
				47
				46
				45
				44
				43
				42
				41
				40
				39
				38
				37
				36
				35
				34
				33
				32
				31
				30
				29
				28
				27
				26
				25
				24
				23
				22
				21
				20
				19
				18
				17
				16
				15
				14
				13
				12
				11
				10
				9
				8
				7
				6
				5
				4
				3
				2
				1

QTY	REF	P/N	DESCRIPTION	ITEM NO
1	1	1		70
REF	REF	REF		69
REF	REF	REF		68
REF	REF	REF		67
REF	REF	REF		66
REF	REF	REF		65
REF	REF	REF		64
REF	REF	REF		63
REF	REF	REF		62
REF	REF	REF		61
REF	REF	REF		60
REF	REF	REF		59
REF	REF	REF		58
				57
1	1	1	690542-2 PAWL, FEED	56
REF	REF	REF	240624-1 PIN, FEED FINGER	55
REF	REF	REF	691499-1 SPRING, FEED FINGER	54
REF	REF	REF	690541-1 HOLDER, FEED FINGER	53
REF	REF	REF	455679-2 LEVER, TERMINAL FEED ARM	52
1	1	1	811242-2 BUMPER, HOLDDOWN	51
1	1	1	690753-1 SPACER, TONKER	50
1	-	-	690602-6 CAM, PRE-FEED 1 5/8 ST	49
-	1	-	690602-5 CAM, PRE-FEED 1 1/8 ST	48
-	-	-	690501-4 CAM, POST-FEED 1 5/8 ST	47
1	1	1	459456-2 APPLICATOR, BASIC (SUBASSY)	46
1	1	1	690191-1 PLUG, NYLON	45
1	1	1	455673-1 RAM	44
1	1	1	690125-1 WASHER, LAMINATED	43
1	1	1	690124-1 WASHER, RAM	42
1	1	1	7-21002-9 BOLT, CRIMPER (5/16x1.00)	41
1	1	1	23241-6 BALL, STEEL	40
1	1	1	690170-1 SPRING, COMPRESSION	39
1	1	1	690142-1 DISC, INSULATION	38
1	1	1	354777-1 WIRE DISC, PLASTIC	37
1	1	1	22480-5 WASHER, SPRING	36
1	1	1	690212-1 POST, RAM	35
1	1	1	690786-1 SUPPORT, TERMINAL	34
REF	REF	REF	455675-1 PLATE, BASE	33
1	1	1	690432-3 SCREW, ADJUSTMENT	32
				31
REF	REF	REF	455689-1 BLOCK, STRIP GUIDE ADJ	30
1	1	1	458144-1 PLATE, STRIP GUIDE	29
1	1	1	2-455888-3 SPACER, FRONT SHEAR DEP	28
2	2	2	1-22284-0 SPRING, DRAG	27
1	1	1	240793-1 LEVER, DRAG RELEASE	26
1	1	1	240792-1 DRAG, TERMINAL	25
1	1	1	1-90765-8 GUIDE, STRIP (REAR)	24
1	1	1	690438-1 GUIDE, STRIP (FRONT)	23
-	-	-	690472-2 STRIPPER	22
REF	REF	REF	4-22284-9 SPRING, FEED RETURN	21
1	1	-	679218-1 STRIPPER WIRE STOP ASSY	20
1	1	-	458949-1 STRIPPER	19
				18
				17
1	1	1	318563-1 GUARD, CHIP, FRONT	16
				15
				14
				13
1	1	1	5-22280-0 SPRING, SHEAR	12
1	1	1	690461-1 STOP, SHEAR	11
1	1	1	690459-1 HOLDER, SHEAR (FRONT)	10
1	1	1	1-454276-9 SHEAR, FLOAT (FRONT)	9
1	1	1	1-662186-9 ANVIL	8
1	1	1	3-240641-9 SPACER, DEPRESSOR (REAR)	7
				6
1	1	1	1-455889-4 DEPRESSOR, SHEAR (FRONT)	5
1	1	1	238011-7 SPACER, BLOCK CRIMPER	4
1	1	1	456134-5 CRIMPER, INSULATION	3
1	1	1	1-455888-4 SPACER, CRIMPER	2
1	1	1	1-456405-3 CRIMPER, WIRE	1

QTY REOD PER ASSY	PARTS LIST					
	MATL	HT TR		FIN		
DIMENSIONS IN INCHES. DO NOT SCALE PRINT. TOLERANCES UNLESS OTHERWISE SPECIFIED:						
DR 160CT98 APP 160CT98						
P.Mothios T.ELBIN						
2 PLC DEC ±						
3 PLC DEC ±						
4 PLC DEC ±						
ANGLES ±						
SURF TEXTURE: ✓						
REMOVE BURRS, BREAK SHARP EDGES R.015 MAX						
	NAME	SCALE			DWG NO	REV
		D			680732	1 OF 1
		CUSTOMER AND ASSEMBLY DRAWING				

THIS DRAWING IS A CONTROLLED DOCUMENT.

THIS DRAWING IS UNRELEASED. RELEASE FOR PUBLICATION BY AMP INCORPORATED. ALL RIGHTS RESERVED. AMP 1756 REV 3-92

680732

D

C

B

A