

Single Chip Power Solution for Battery Powered Systems

Check for Samples: [TPS65070-Q1](#), [TPS65072-Q1](#), [TPS65073-Q1](#), [TPS650732-Q1](#)

FEATURES

- Qualified for Automotive Applications
- Charger/Power Path Management:
 - 2A Output Current on the Power Path
 - Linear Charger; 1.5A Maximum Charge Current
 - 100mA/500mA/ 800mA/1300mA Current Limit From USB Input
 - Thermal Regulation, Safety Timers
 - Temperature Sense Input
- 3 Step-Down Converters:
 - 2.35MHz Fixed Frequency Operation
 - Up to 1.5A of Output Current
 - Adjustable or Fixed Output Voltage
 - V_{IN} Range From 2.8V to 6.3V
 - Power Save Mode at Light Load Current
 - Output Voltage Accuracy in PWM Mode $\pm 1.5\%$
 - Typical 19 μ A Quiescent Current per Converter
 - 100% Duty Cycle for Lowest Dropout
- LDOs:
 - Fixed Output Voltage
 - Dynamic Voltage Scaling on LDO2
 - 20 μ A Quiescent Current
 - 200mA Maximum Output Current
 - V_{IN} Range From 1.8V to 6.3V
- wLED Boost Converter:
 - Internal Dimming Using I²C
 - Up to 2 × 10 LEDs
 - Up to 25mA per String With Internal Current Sink
- I²C Interface

- 10 Bit A/D Converter
- Touch Screen Interface
- Undervoltage Lockout and Battery Fault Comparator

APPLICATIONS

- Portable Navigation Systems
- Low-Power DSP Supply

DESCRIPTION

The TPS6507x are single chip Power Management ICs for portable applications consisting of a battery charger with power path management for a single Li-Ion or Li-Polymer cell. The charger can either be supplied by a USB port on pin *USB* or by a dc voltage from a wall adapter connected to pin *AC*. Three highly efficient 2.25MHz step-down converters are targeted at providing the core voltage, memory and I/O voltage in a processor based system. The step-down converters enter a low power mode at light load for maximum efficiency across the widest possible range of load currents. For low noise applications the devices can be forced into fixed frequency PWM using the I²C interface. The step-down converters allow the use of small inductors and capacitors to achieve a small solution size. The TPS6507x also integrate two general purpose LDOs for an output current of 200mA. These LDOs can be used to power an SD-card interface and an *always-on* rail, but can be used for other purposes as well. Each LDO operates with an input voltage range between 1.8V and 6.3V allowing them to be supplied from one of the step-down converters or directly from the main battery. An inductive boost converter with two programmable current sinks power two strings of white LEDs.

The TPS6507x come in a 48-pin leadless package (6mm × 6mm QFN) with a 0.4mm pitch.



Please be aware that an important notice concerning availability, standard warranty, and use in critical applications of Texas Instruments semiconductor products and disclaimers thereto appears at the end of this data sheet.

PowerPAD is a trademark of Texas Instruments.

PRODUCTION DATA information is current as of publication date. Products conform to specifications per the terms of the Texas Instruments standard warranty. Production processing does not necessarily include testing of all parameters.

Copyright © 2011, Texas Instruments Incorporated



These devices have limited built-in ESD protection. The leads should be shorted together or the device placed in conductive foam during storage or handling to prevent electrostatic damage to the MOS gates.

ORDERING INFORMATION

T _A	OUTPUT VOLTAGE AT DCDC3	OUTPUT VOLTAGE AT DCDC1/DCDC2	OUTPUT VOLTAGE AT LDO1/LDO2	OUTPUT CURRENT AT DCDC1/DCDC2/DCDC3	PACKAGE		PART NUMBER ⁽¹⁾	TOP-SIDE MARKING
-40°C to 105°C	1.0V / 1.2V (OMAP-L1x8)	3.3V / 1.8V / 3.3V	1.8V / 1.2V	0.6A / 1.5A / 1.5A	VQFN-48 RSL	Reel of 2500	TPS65070TRSLRQ1	Preview
	1.2V / 1.4V (Atlas IV)	3.3V / 1.8V / 2.5V	1.2V / 1.2V	3 x 600 mA	VQFN-48 RSL	Reel of 2500	TPS65072TRSLRQ1	Preview
	1.2V / 1.35V (OMAP35xx)	1.8V / 1.2V / 1.8V	1.8V / 1.8V	0.6A / 0.6A / 1.5A External sequencing	VQFN-48 RSL	Reel of 2500	TPS65073TRSLRQ1	Preview
	1.2V / 1.35V (OMAP35xx)	1.8V / 1.2V / 1.8V	1.8V / 1.8V	0.6A / 0.6A / 1.5A Internal sequencing	VQFN-48 RSL	Reel of 2500	TPS650731TRSLRQ1	Preview
	1.2V / 1.35V (AM3505)	1.8V / 1.8V / 3.3V	1.8V / 1.8V	0.6A / 0.6A / 1.5A Internal sequencing	VQFN-48 RSL	Reel of 2500	TPS650732TRSLRQ1	TPS650732T

(1) Package drawings, thermal data, and symbolization are available at www.ti.com/packaging.

ABSOLUTE MAXIMUM RATINGS⁽¹⁾

over operating free-air temperature range (unless otherwise noted)

	VALUE / UNIT
Voltage range on all pins except the pins listed below with respect to AGND	-0.3 to 7V
Voltage range on pins \overline{INT} , \overline{RESET} , PGOOD, PB_OUT with respect to AGND	-0.3 to V(AVDD6)
Voltage range on pins VINDCDC1/2, VINDCDC3, VINLDO respect to AGND	-0.3 to V(SYS)
Voltage range on pins AD_IN1, AD_IN2, AD_IN3, AD_IN4 with respect to AGND	-0.3 to 3.3 V
Voltage range on pins ISINK1, ISINK2, AC, USB	-0.3 to 20 V
Voltage range on pin L4 (output voltage of boost converter), FB_wLED	-0.3 to 40 V
Current at SYS, AC, USB, BAT, L3	3000 mA
Current at all other pins	1000 mA
Continuous total power dissipation	See Dissipation Rating Table
Operating free-air temperature, T _A	40°C to 105°C
Maximum junction temperature, T _J	125°C
Storage temperature, T _{st}	-65°C to 150°C

(1) Stresses beyond those listed under *absolute maximum ratings* may cause permanent damage to the device. These are stress ratings only and functional operation of the device at these or any other conditions beyond those indicated under *recommended operating conditions* is not implied. Exposure to absolute-maximum-rated conditions for extended periods may affect device reliability.

DISSIPATION RATINGS⁽¹⁾

PACKAGE	R _{θJA}	T _A ≤ 25°C POWER RATING	DERATING FACTOR ABOVE T _A = 25°C	T _A = 70°C POWER RATING	T _A = 85°C POWER RATING	T _A = 105°C POWER RATING
RSL	37 K/W	2.6 W	26 mW/K	1.48 W	1.0 W	520 mW

(1) The thermal resistance R_{θJ-P} junction to PowerPAD of the RSL package is 1.1 K/W. The value for R_{θJA} was measured on a high K board.

RECOMMENDED OPERATING CONDITIONS

		MIN	NOM	MAX	UNIT
BATTERY CHARGER AND POWER PATH					
V _{IN}	Input voltage for power path manager at pins AC or USB	4.30		17	V
	Input voltage for power path manager at pins AC or USB, charger and power path active (no overvoltage lockout)	4.30		5.8	
	Input voltage for power path manager at pins AC or USB in case there is no battery connected at pin BAT	3.6		17	
I _{IN}	Input current at AC pin			2.5	A
	Input current at USB pin			1.3	
I _{BAT}	Current at BAT pin			2	A
DCDC CONVERTERS AND LDOs					
V _{INDCDC}	Input voltage range for step-down converter DCDC1, DCDC2, DCDC3	2.8		6.3 ⁽¹⁾	V
V _{DCDC1}	Output voltage range for VDCDC1 step-down converter	0.6		VINDCDC1	V
V _{DCDC2}	Output voltage range for VDCDC2, DCDC3 step-down converter	0.6		VINDCDC2	V
V _{INLDOx}	Input voltage range for LDO1 and LDO2	1.8		6.3 ⁽¹⁾	V
V _{LDO1}	Output voltage range for LDO1	0.9		3.3	V
V _{LDO2}	Output voltage range for LDO2	0.8		3.3	V
I _{OUTDCDC1}	Output current at L1		600		mA
L1	Inductor at L1 ⁽²⁾	1.5	2.2		μH
C _{INDCDC12}	Input Capacitor at VINDCDC1 and VINDCDC2 ⁽²⁾	22			μF
C _{OUTDCDC1}	Output Capacitor at VDCDC1 ⁽²⁾	10	22		μF
I _{OUTDCDC2}	Output current at L2		1500		mA
L2	Inductor at L2 ⁽²⁾	1.5	2.2		μH
C _{OUTDCDC2}	Output Capacitor at VDCDC2 ⁽²⁾	10	22		μF
I _{OUTDCDC3}	Output current at L3		1500		mA
L3	Inductor at L3 ⁽²⁾	1.5	2.2		μH
C _{INDCDC3}	Input Capacitor at VINDCDC3 ⁽²⁾	10			μF
C _{OUTDCDC3}	Output Capacitor at VDCDC3 ⁽²⁾	10	22		μF
L4	Inductor at L4 ⁽²⁾		22		μH
C _{OUTWLED}	Output Capacitor at wLED boost converter	4.7			μF
C _{INLDO1/2}	Input Capacitor at VINLDO1/2	2.2			μF
C _{OUTLDO1}	Output Capacitor at VLDO1	2.2			μF
I _{OUTLDO1}	Output Current at VLDO1		100		mA
C _{OUTLDO2}	Output Capacitor at VLDO2	2.2			μF
I _{OUTLDO2}	Output Current at VLDO2		100		mA
C _{AC}	Input Capacitor at AC	1			μF
C _{USB}	Input Capacitor at USB	1			μF
C _{BAT}	Capacitor at BAT pin	10			μF
C _{SYS}	Capacitor at SYS pin	22		100 ⁽³⁾	μF
C _{BYPASS}	Capacitor at BYPASS pin	10			μF
C _{INT_LDO}	Capacitor at INT_LDO pin	2.2			μF
C _{AVDD6}	Capacitor at AVDD6 pin	4.7			μF
T _A	Operating ambient temperature	-40		105	°C
T _J	Operating junction temperature	-40		125	°C

(1) 6.3 V or V_{SY} whichever is less

(2) See application section for more details

(3) For proper soft-start

ELECTRICAL CHARACTERISTICS

VSYS = 3.6V, EN_DCDCx = VSYS, L = 2.2μH, C_{OUT} = 10μF, T_A = –40°C to 105°C typical values are at T_A = 25°C (unless otherwise noted)

PARAMETER		TEST CONDITIONS	MIN	TYP	MAX	UNIT
SUPPLY CURRENT						
V _{INDCDC}	Input voltage range for DCDC converters		2.8		6.3	V
I _Q	Operating quiescent current Total current into VSYS, VINDCDCx, VINLDO1/2	Only DCDC2, DCDC3 and LDO1 enabled, device in ON-mode; DCDC converters in PFM		140		μA
		Per DC/DC converter, PFM mode		19	30	
		Per DC/DC converter, PWM mode		2.5		
		For LDO1 or LDO2 (either one enabled)		20	35	
		For LDO1 and LDO2 (both enabled)		34		
		For wLED converter		1.5		mA
I _{SD}	Shutdown current	All converters, LDOs, wLED driver and ADC disabled, no input voltage at AC and USB; SYS voltage turned off		8	12	μA
V _{UVLO}	Undervoltage lockout threshold	Voltage at the output of the power manager detected at pin SYS; falling voltage, voltage defined with <UVLO0>, <UVLO1> DEFAULT: 3.0V	–2%	2.8	2%	V
				3.0 3.1 3.25		
	Undervoltage lockout hysteresis	Rising voltage defined with <UVLO hysteresis>; DEFAULT: 500mV		360 450		mV
	Undervoltage lockout deglitch time	Due to internal delay		4		ms
T _{SD}	Thermal shutdown for DCDC converters, wLED driver and LDOs	Increasing junction temperature		150		°C
	Thermal shutdown hysteresis	Decreasing junction temperature		20		°C
EN_DCDC1, EN_DCDC2, EN_DCDC3, DEFDCDC2, DEFDCDC3, SDAT, SCLK, EN_wLED (optional)						
V _{IH}	High Level Input Voltage, EN_DCDC1, EN_DCDC2, EN_DCDC3, DEFDCDC2, DEFDCDC3, SDAT, SCLK, EN_wLED		1.2		V _{sys}	V
V _{IL}	Low Level Input Voltage, EN_DCDC1, EN_DCDC2, EN_DCDC3, DEFDCDC2, DEFDCDC3, SDAT, SCLK, EN_wLED		0		0.4	V
I _{IN}	Input bias current, EN_DCDC1, EN_DCDC2, EN_DCDC3, DEFDCDC2, DEFDCDC3, SDAT, SCLK			0.01	1.0	μA

DCDC1 CONVERTER

PARAMETER		TEST CONDITIONS	MIN	TYP	MAX	UNIT
V _{VINDCDC1}	Input voltage range	Connected to SYS pin	2.8		6.3	V
I _O	Maximum output		600			mA
R _{DS(ON)}	High side MOSFET on-resistance	VINDCDC1 = 2.8 V		150	300	mΩ
		VINDCDC1 = 3.5 V		120	200	
I _{LH}	High side MOSFET leakage current	VINDCDC1 = 6.3 V			2	μA
R _{DS(ON)}	Low side MOSFET on-resistance	VINDCDC1 = 2.8 V		200	300	mΩ
		VINDCDC1 = 3.5 V		160	180	
I _{LL}	Low side MOSFET leakage current	V _{DS} = 6.3 V			1	μA
I _{LIMF}	Forward current limit	for TPS65072, TPS65073, TPS650731, TPS650732	0.8	1.1	1.5	A
I _{LIMF}	Forward current limit	for TPS65070	1.1	1.6	2.2	A
f _S	Oscillator frequency		1.95	2.35	2.55	MHz
V _{out}	Fixed output voltage range	Internal resistor divider, I ² C selectable	0.725		3.3	V
V _{out}	Default output voltage	For TPS65070, TPS65072		3.3		V
		For TPS65073, TPS650731, TPS650732		1.8		
V _{out}	DC output voltage accuracy; PFM mode ⁽¹⁾	VINDCDC1 = VDCDC1 +0.3 V to 6.3 V; 0 mA ≤ I _O ≤ 0.6 A	-2%		3%	
V _{out}	DC output voltage accuracy; PWM mode ⁽¹⁾	VINDCDC1 = VDCDC1 +0.3 V to 6.3 V; 0 mA ≤ I _O ≤ 0.6 A	-1.5%		1.5%	
ΔV _{OUT}	Power save mode ripple voltage ⁽²⁾	I _{OUT} = 1 mA, PFM mode		40		mV _{pp}
t _{Start}	Start-up time	Time from active EN to Start switching		170		μs
t _{Ramp}	V _{OUT} ramp up time	Time to ramp from 5% to 95% of V _{OUT}		250		μs
	power good threshold	rising voltage		V _O - 5%		
	power good threshold	falling voltage		V _O - 10%		
R _{DIS}	Internal discharge resistor at L1		-35%	250	35%	Ω

(1) Output voltage specification does not include tolerance of external voltage programming resistors. Output voltage in PFM mode is scaled to +1% of nominal value.

(2) Configuration L= 2.2 μH, C_{OUT} = 10 μF

DCDC2 CONVERTER

PARAMETER		TEST CONDITIONS	MIN	TYP	MAX	UNIT	
V _{VINDCDC2}	Input voltage range	Connected to SYS pin	2.8		6.3	V	
I _O	Maximum output current	TPS65072/73/731/732		600		mA	
		TPS65070	V _{in} > 2.8 V	1500			
R _{DS(ON)}	High side MOSFET on-resistance	VINDCDC2 = 2.8 V		150	300	mΩ	
		VINDCDC2 = 3.5 V		120	200		
I _{LH}	High side MOSFET leakage current	VINDCDC2 = 6.3 V			2	μA	
R _{DS(ON)}	Low side MOSFET on-resistance	VINDCDC2 = 2.8 V		200	300	mΩ	
		VINDCDC2 = 3.5 V		160	180		
I _{LL}	Low side MOSFET leakage current	V _{DS} = 6.3 V			1	μA	
I _{LIMF}	Forward current limit	TPS65072/73/731/732	2.8 V < V _{VINDCDC2} < 6.3 V	0.8	1.1	1.5	A
		TPS65070		2.1	2.4	3.5	
f _S	Oscillator frequency		1.95	2.35	2.55	MHz	
V _{out}	Adjustable output voltage range	External resistor divider	0.6		V _{in}	V	
V _{ref}	Reference voltage			600		mV	
V _{out}	Fixed output voltage range	Internal resistor divider, I ² C selectable (Default setting)	0.725		3.3	V	

DCDC2 CONVERTER (continued)

PARAMETER		TEST CONDITIONS	MIN	TYP	MAX	UNIT
V _{out}	Default output voltage for TPS65070, TPS650732	For DEFDCDC2 = LOW		1.8		V
		For DEFDCDC2 = HIGH		3.3		
	Default output voltage for TPS65072	For DEFDCDC2 = LOW		1.8		
		For DEFDCDC2 = HIGH		2.5		
	Default output voltage for TPS65073, TPS650731	For DEFDCDC2 = LOW		1.2		
		For DEFDCDC2 = HIGH		1.8		
V _{out}	DC output voltage accuracy; PFM mode ⁽¹⁾	VINDCDC2 = 2.8 V to 6.3 V; 0 mA ≤ I _O ≤ 1.5 A	-2%		3%	
	DC output voltage accuracy; PWM mode ⁽¹⁾		-1.5%		1.5%	
	DC output voltage accuracy with resistor divider at DEFDCDC2; PFM	VINDCDC2 = VDCDC2 + 0.3 V (min 2.8 V) to 6.3 V; 0 mA ≤ I _O ≤ 1.5A	-2%		3%	
	DC output voltage accuracy with resistor divider at DEFDCDC2; PWM		-1%		1%	
ΔV _{OUT}	Power save mode ripple voltage	I _{OUT} = 1 mA, PFM mode ⁽²⁾		40		mV _{pp}
t _{Start}	Start-up time	Time from active EN to Start switching		170		μs
t _{Ramp}	V _{OUT} ramp up time	Time to ramp from 5% to 95% of V _{OUT}		250		μs
	power good threshold	rising voltage		V _O - 5%		
	power good threshold	falling voltage		V _O - 10%		
R _{DIS}	Internal discharge resistor at L2		-35%	250	35%	Ω

(1) Output voltage specification does not include tolerance of external voltage programming resistors. Output voltage in PFM mode is scaled to +1% of nominal value.

(2) Configuration L = 2.2 μH, C_{OUT} = 10 μF

DCDC3 CONVERTER

PARAMETER		TEST CONDITIONS	MIN	TYP	MAX	UNIT	
V _{VINDCDC3}	Input voltage range	Connected to SYS pin	2.8		6.3	V	
I _O	Maximum output current	Vin > 2.8 V	TPS65072	600		mA	
			TPS65070, TPS65073, TPS650731, TPS650732	1500			
R _{DS(ON)}	High side MOSFET on-resistance	VINDCDC3 = 2.8 V		150	300	mΩ	
		VINDCDC3 = 3.5 V		120	200		
I _{LH}	High side MOSFET leakage current	VINDCDC3 = 6.3 V			2	μA	
R _{DS(ON)}	Low side MOSFET on-resistance	VINDCDC3 = 2.8 V		200	300	mΩ	
		VINDCDC3 = 3.5 V		160	180		
I _{LL}	Low side MOSFET leakage current	V _{DS} = 6.3 V			1	μA	
I _{LIMF}	Forward current limit	2.8 V < V _{INDCDC3} < 6.3 V	TPS65072	0.8	1.1	1.5	A
			TPS65070/73/731/732	2.1	2.4	3.5	
f _S	Oscillator frequency		1.95	2.35	2.55	MHz	
V _{out}	Adjustable output voltage range	External resistor divider	0.6		V _{in}	V	
V _{ref}	Reference voltage			600		mV	
V _{out}	Fixed output voltage range	Internal resistor divider, I ² C selectable (Default setting)	0.725		3.3	V	
V _{out}	Default output voltage for TPS65070	For DEFDCDC3 = LOW		1.0		V	
		For DEFDCDC3 = HIGH		1.2			
	Default output voltage for TPS65072	For DEFDCDC3 = LOW		1.2			
		For DEFDCDC3 = HIGH		1.4			
	Default output voltage for TPS65073, TPS650731, TPS650732	For DEFDCDC3 = LOW		1.2			
		For DEFDCDC3 = HIGH		1.35			
V _{out}	DC output voltage accuracy; PFM mode ⁽¹⁾	VINDCDC3 = 2.8 V to 6.3 V; 0 mA ≤ I _O ≤ 1.5 A	-2%		3%		
	DC output voltage accuracy; PWM mode ⁽¹⁾		-1.5%		1.5%		

(1) Output voltage specification does not include tolerance of external voltage programming resistors. Output voltage in PFM mode is scaled to +1% of nominal value.

DCDC3 CONVERTER (continued)

PARAMETER		TEST CONDITIONS	MIN	TYP	MAX	UNIT
V _{out}	DC output voltage accuracy with resistor divider at DEFDCDC3; PFM	V _{INDCDC3} = V _{DCDC3} + 0.3 V (min 2.8 V) to 6.3 V; 0 mA ≤ I _O ≤ 1.5A	-2%		3%	
V _{out}	DC output voltage accuracy with resistor divider at DEFDCDC3; PWM		-1%		1%	
ΔV _{OUT}	Power save mode ripple voltage	I _{OUT} = 1 mA, PFM mode ⁽²⁾		40		mV _{pp}
t _{Start}	Start-up time	Time from active EN to Start switching		170		μs
t _{Ramp}	V _{OUT} ramp up time	Time to ramp from 5% to 95% of V _{OUT}		250		μs
	power good threshold	rising voltage		V _O - 5%		
	power good threshold	falling voltage		V _O - 10%		
R _{DIS}	Internal discharge resistor at L3		-35%	250	35%	Ω

(2) Configuration L= 2.2 μH, C_{OUT} = 10 μF

VLDO1 and VLDO2 LOW DROPOUT REGULATORS

PARAMETER		TEST CONDITIONS	MIN	TYP	MAX	UNIT
V_{INLDO}	Input voltage range for LDO1, LDO2		1.8		6.3 ⁽¹⁾	V
V_{LDO1}	LDO1 output voltage range		1.0		3.3	V
V_{LDO2}	LDO2 output voltage range	Voltage options available see register description	0.725		3.3	V
I_O	Output current for LDO1				200	mA
V_{LDO1}	LDO1 default output voltage	For TPS65072		1.2		V
		For TPS65070, TPS65073, TPS650731, TPS650732		1.8		
V_{LDO2}	LDO2 default output voltage	For TPS65070		1.2		V
		For TPS65072		1.2		
		For TPS65073, TPS650731, TPS650732		1.8		
I_O	Output current for LDO2				200	mA
I_{SC}	LDO1 short circuit current limit	$V_{LDO1} = GND$			400	mA
I_{SC}	LDO2 short circuit current limit	$V_{LDO2} = GND$			400	mA
	Minimum voltage drop at LDO1	$I_O = 100\text{ mA}$, $V_{INLDO} = 3.3\text{ V}$			150	mV
	Minimum voltage drop at LDO2	$I_O = 100\text{ mA}$, $V_{INLDO} = 3.3\text{ V}$			150	mV
	Output voltage accuracy for LDO1, LDO2	ILDO1 = 100 mA; ILDO2 = 100 mA; $V_{in} \geq V_{out} + 200\text{ mV}$	-1%		1.5%	
	Line regulation for LDO1, LDO2	$V_{INLDO1,2} = V_{LDO1,2} + 0.5\text{ V}$ (min. 2.8 V) to 6.5 V, ILDO1 = 100 mA; ILDO2 = 100 mA	-1%		1%	
	Load regulation for LDO1, LDO2	$I_O = 1\text{ mA}$ to 200 mA	-1%		1%	
	Load regulation for LDO1, LDO2	$I_O < 1\text{ mA}$; $V_o < 1\text{ V}$	-2.5%		2.5%	
R_{DIS}	Internal discharge resistor at VLDO1, VLDO2			400		Ω
t_{Ramp}	V_{OUT} ramp up time	Time to ramp from 5% to 95% of V_{OUT}		250		μs

(1) 6.3 V or VSYS whichever is less

wLED BOOST CONVERTER

PARAMETER		TEST CONDITIONS	MIN	TYP	MAX	UNIT
V _{L4}	voltage at L4 pin		2.8		39	V
V _{sink1,2}	Input voltage at ISINK1, ISINK2 pins				16	V
V _{OUT}	Internal overvoltage protection		35	37	39	V
	Maximum boost factor (Vout/Vin)	I _{sink1} = I _{sink2} = 20 mA, V _{in} = 2.8 V	9	10		
T _{min_off}	Minimum off pulse width			70		ns
R _{DS(ON)}	N-channel MOSFET on-resistance	V _{L4} = 3.6 V		0.6		Ω
	N-channel MOSFET current limit		0.8	1.6	2.0	A
I _{LN_NFET}	N-channel leakage current	V _{DS} = 25 V, T _A = 25°C			1	μA
	Switching frequency			1.125		MHz
V _{sink1} , V _{sink2}	Minimum voltage drop at Isink pin to GND for proper regulation			400		mV
V _{ISET}	ISET pin voltage			1.24		V
K _{ISET}	Current multiple Iout/Iset	Iset current = 15 μA		1000		
		Iset current = 25 μA		1000		
I _{sink1} , I _{sink2}	Minimum current into ISINK1, ISINK2 pins	For proper dimming (string can be disabled also)			4	mA
	Maximum current into ISINK1, ISINK2 pins	V _{in} = 3.3 V		25		mA
	DC current set accuracy	I _{sinkx} = 5 mA to 25 mA; no PWM dimming			±5%	
	Current difference between Isink1 and Isink2	Rset1 = 50k; Isink1 = 25 mA, V _{in} = 3.6 V; no PWM dimming			±5%	
	Current difference between Isink1 and Isink2	Rset2 = 250k; Isink1 = 5 mA, V _{in} = 3.6 V; no PWM dimming			±5%	
f _{PWM}	PWM dimming frequency	PWM dimming Bit = 00	-15%	100	15%	Hz
		PWM dimming Bit = 01 (default)	-15%	200	15%	
		PWM dimming Bit = 10	-15%	500	15%	
		PWM dimming Bit = 11	-15%	1000	15%	
	Rise / fall time of PWM signal	For all PWM frequencies		2		μs
	Dimming PWM DAC resolution			1%		

Reset, PB_IN, PB_OUT, PGood, Power_on, INT, EN_EXTLDO, EN_wLED

PARAMETER		TEST CONDITIONS	MIN	TYP	MAX	UNIT
	Reset delay time and PGOOD delay time	Input voltage at threshold pin rising; time defined with <PGOOD DELAY0>, <PGOOD DELAY1>	-15%	20 100 ⁽¹⁾ 200 400	15%	ms
	PB-IN debounce time		-15%	50	15%	ms
	PB_IN "Reset-detect- time"	Internal timer	-15%	15	15%	s
	PGOOD low time when PB_IN = Low for >15s		-15%	0.5	15%	ms
V _{IH}	High level input voltage on pin POWER_ON		1.2		V _{IN}	V
V _{IH}	High level input voltage on pin PB_IN		1.8		AVDD6	V
V _{IL}	Low Level Input Voltage, PB_IN, Power_on		0		0.4	V
	Internal pull-up resistor from PB_IN to AVDD6			50		kΩ
	Output current at AVDD6				1	mA
I _{IN}	Input bias current at Power_on			0.01	1.0	μA
V _{OL}	Reset, PB_OUT, PGood, INT output low voltage, EN_EXTLDO	I _{OL} = 1 mA, V _{threshold} < 1 V			0.3	V
VOH	EN_EXTLDO HIGH level output voltage	I _{OH} = 0.1 mA; optional push pull output			VSYS	V
I _{OL}	Reset, PB_OUT, PGood, INT sink current			1		mA
	Reset, PB_OUT, PGood, INT output leakage current	Reset, PB_OUT, PGood, INT open drain output in high impedance state			0.25	μA
V _{th}	Threshold voltage at THRESHOLD pin	Input voltage falling	-4%	1	4%	V
V _{th_hyst}	Hysteresis on THRESHOLD pin	Input voltage rising		7		mV
I _{in}	Input bias current at EN_wLED, THRESHOLD				1	μA

(1) Default Reset delay time is set to 100 ms typical

ADC CONVERTER

PARAMETER		TEST CONDITIONS	MIN	TYP	MAX	UNIT
V _{IN}	Input voltage range at AD_IN1 to AD_IN4 pin (channel 0 to channel 3)	For full scale measurement	0		2.25	V
	Input voltage range internal channel 6 to channel 9	For full scale measurement	0		6	
	Input voltage range on channel4 (TS pin) and channel5 (ISET pin)	Unipolar measurement of charge current at pin ISET (voltage at ISET)	0		2.25	
I _{in}	AD_IN1 to AD_IN4 input current			0.1	4	μA
C _{in}	Input capacitance at AD_IN1 to AD_IN4			15		pF
	ADC resolution			10		Bits
	Differential linearity error			±1		LSB
	Offset error			1	5	LSB
	Gain error			±8		LSB
	Sampling time			220		μs
	Conversion time			19		μs
	Wait time after enable	Time needed to stabilize the internal voltages	1.5			ms
	Quiescent current, ADC enabled by I ² C	includes current needed for I2C block		500		μA
	Quiescent current, conversion ongoing				1	mA
	Reference voltage output on pin BYPASS		-1%	2.260	1%	V
	Output current on reference output pin BYPASS				0.1	mA

TOUCH SCREEN INTERFACE

PARAMETER		TEST CONDITIONS	MIN	TYP	MAX	UNIT
V _{TSREF}	Voltage at internal voltage regulator for TSC			2.30		V
TOUCHSCREEN PANEL SPECIFICATIONS						
	Plate resistance X	Specified by design	200	400	1200	Ω
	Plate resistance Y	Specified by design	200	400	1200	Ω
	Resistance between plates contact		180	400	1000	Ω
	Resistance between plates pressure		180	400	1000	Ω
	Settling time	Position measurement; 400 Ω, 100 pF		5.5		μs
	Capacitance between plates			2	10	nF
	Total capacitance at pins TSX1,TSX2,TSY1,TSY2 to GND				100	pF
	internal TSC reference resistance		20.9	22	23.1	kΩ
SWITCH MATRIX SPECIFICATIONS						
	Tgate resistance	Specified by design	111	160	230	Ω
	PMOS resistance	Specified by design			20	Ω
	NMOS resistance	Specified by design			20	Ω
	Quiescent supply current	in TSC standby mode with TSC_M[2..0] = 101		10		μA

POWER PATH

PARAMETER		TEST CONDITIONS	MIN	TYP	MAX	UNIT
QUIESCENT CURRENT						
I _{QSP1}	Quiescent current, AC or USB mode	Current into AC or USB, AC or USB selected, no load at SYS			20	μA
INPUT SUPPLY						
V _{BATMIN}	Minimum battery voltage for BAT SWITCH operation	No input power, BAT_SWITCH on	2.75			V
V _{IN(DT)}	Input voltage detection threshold	AC detected when V(AC)-V(BAT) > V _{IN(DT)} ; USB detected when V(USB)-V(BAT) > V _{IN(DT)}	150			mV
V _{IN(NDT)}	Input Voltage removal threshold	AC not detected when V(AC)-V(BAT) < V _{IN(NDT)} ; USB not detected when V(USB)-V(BAT) < V _{IN(NDT)}			75	mV
I _{DISCH}	Internal discharge current at AC and USB input	Activated based on settings in CHGCONFIG3 Bit 0 and Bit 7		95		μA

POWER PATH (continued)

PARAMETER		TEST CONDITIONS	MIN	TYP	MAX	UNIT
$T_{DGL(DT)}$	Power detected deglitch	AC or USB voltage increasing		22.5		ms
$V_{IN(OVP)}$	Input over voltage detection threshold		5.8	6	6.3	V
POWER PATH TIMING						
$T_{SW(ACBAT)}$	Switching from AC to BAT	No USB, AC power removed			200	μ s
$S_{W(USBAT)}$	T Switching from USB to BAT	No AC, USB power removed			200	μ s
$T_{SW(PSEL)}$	Switching from USB to AC	I2C			150	μ s
$T_{SW(ACUSB)}$	Switching from AC/ USB, USB / AC	AC power removed or USB power removed			200	μ s
T_{SYSOK}	SYS power up delay	Measured from power applied to start of power-up sequence		11		ms
POWER PATH INTEGRATED MOSFETS CHARACTERISTICS						
	AC Input switch dropout voltage	($I_{LIMIT_{AC}}$ set = 2.5 A $I(SYS) = 1$ A)		150		mV
	USB input switch dropout voltage	$I_{LIMIT_{USB}} = 1300$ mA $I(SYS) = 500$ mA $I_{LIMIT_{USB}} = 1300$ mA $I(SYS) = 800$ mA		100 160		mV
	Battery switch dropout voltage	$V(BAT) = 3.0$ V, $I(BAT) = 1$ A		85	100	mV
Input Current Limit						
I_{USB100}	Input current limit; USB pin	USB input current [0,0]	90		100	mA
I_{USB500}	Input current limit; USB pin	USB input current [0,1] (default)	450		500	mA
I_{USB800}	Input current limit; USB pin	USB input current [1,0]	700		800	mA
$I_{USB1300}$	Input current limit; USB pin	USB input current [1,1]	1000		1300	mA
I_{AC100}	Input current limit; AC pin	AC input current [0,0]	90		100	mA
I_{AC500}	Input current limit; AC pin	AC input current [0,1]	450		500	mA
I_{A1300}	Input current limit; AC pin	AC input current [1,0]	1000		1300	mA
I_{AC2500}	Input current limit; AC pin	AC input current [1,1] (default)	2000		2500	mA
POWER PATH SUPPLEMENT DETECTION PROTECTION AND RECOVERY FUNCTIONS						
V_{BSUP1}	Enter battery supplement mode	AC input current set to 10: 1.3A		$V_{OUT} \leq V_{BAT} - 45$ mV		
V_{BSUP2}	Exit battery supplement mode			$V_{OUT} \geq V_{BAT} - 35$ mV		
$V_{SYS(SC1)}$	Sys short-circuit detection threshold, power-on	All power path switches set to OFF if $V_{SYS} < V_{SYS(SC1)}$	1.4	1.8	2.0	V
	Short circuit detection threshold hysteresis			50		mV
$R_{FLT(AC)}$	Sys Short circuit recovery pull-up resistors	Internal resistor connected from AC to SYS; Specified by design		500		Ω
$R_{FLT(USB)}$	Sys Short circuit recovery pull-up resistors	Internal resistor connected from USB to SYS; Specified by design		500		Ω
$V_{SYS(SC2)}$	Output short-circuit detection threshold, supplement mode $V_{BAT} - V_{SYS} > V_{O(SC2)}$ indicates short-circuit		200	250	300	mV
$t_{DGL(SC2)}$	Deglitch time, supplement mode short circuit			120		μ s
$t_{REC(SC2)}$	Recovery time, supplement mode short circuit			60		ms
$V_{BAT(SC)}$	BAT pin short-circuit detection threshold		1.4	1.8	2.0	V
$I_{BAT(SC)}$	Source current for BAT pin short-circuit detection		4	7.5	11	mA
DPPM LOOP⁽¹⁾						
V_{DPM}	Threshold at which DPPM loop is enabled. This is the approximate voltage at SYS pin, when the USB or AC switch reaches current limit and the charging current is reduced; Selectable by I2C	Set with Bits <PowerPath DPPM threshold1>; <PowerPath DPPM threshold0>		3.5 3.75 4.25 4.50		V

(1) If the DPPM threshold is lower than the battery voltage, supplement mode will be engaged first and the SYS voltage will chatter around the battery voltage; during that condition no DPPM mode is available.

BATTERY CHARGER (1)

PARAMETER		TEST CONDITIONS	MIN	TYP	MAX	UNIT
CHARGER SECTION						
	Battery discharge current				2	A
V _{O(BATREG)}	Battery charger voltage	Depending on setting in CHGCONFIG2 And internal EEPROM Default = 4.20V	-1%	4.10	1%	V
			-1%	4.15	1%	
			-1%	4.20	1%	
			-1%	4.25	1%	
V _{LOWV}	Pre-charge to fast-charge transition threshold	default = 2.9 V set with Bit <Precharge Voltage>		2.9 2.5		V
t _{DGL1(L0VV)}	Deglitch time on pre-charge to fast-charge transition			25		ms
t _{DGL2(L0VV)}	Deglitch time on fast-charge to pre-charge transition			25		ms
I _{CHG}	Battery fast charge current range	V _{BAT(REG)} > V _{BAT} > V _{LOWV} , V _{IN} = V _{AC} OR V _{USB} = 5 V	100		1500	mA
I _{CHG}	Battery fast charge current	V _{BAT} > V _{LOWV} , V _{IN} = 5 V, I _{IN-MAX} > I _{CHG} , no load on SYS pin, thermal loop not active, DPPM loop not active		K _{ISET} /R _{ISET}		A
K _{ISET}	Fast charge current factor	for a charge current of 1500 mA	840	900	1000	AΩ
K _{ISET}	Fast charge current factor	for a charge current of 100 mA	930	1100	1200	AΩ
I _{PRECHG}	Pre-charge current		0.08× I _{CHG}	0.1× I _{CHG}	0.12× I _{CHG}	A
I _{TERM}	Charge current value for termination detection threshold (internally set)		0.08× I _{CHG}	0.1× I _{CHG}	0.13× I _{CHG}	A
t _{DGL(TERM)}	Deglitch time, termination detected			25		ms
V _{RCH}	Recharge detection threshold	Voltage below nominal charger voltage	150	100	65	mV
t _{DGL(RCH)}	Deglitch time, recharge threshold detected			125		ms
t _{DGL(NO-IN)}	Delay time, input power loss to charger turn-off	V _{BAT} = 3.6V. Time measured from V _{IN} : 5V → 3.3V 1μs fall-time		20		ms
I _{BAT(DET)}	Sink current for battery detection		3		10	mA
t _{DET}	Battery detection timer			250		ms
T _{CHG}	Charge safety timer	Safety timer range, thermal and DPM not active selectable by I2C with Bits <ChargeSafetyTimerValue1> <ChargeSafetyTimerValue0>	-15%	4 5 6 8	15%	h
T _{PRECHG}	Precharge timer	Pre charge timer range, thermal and DPM/DPPM loops not active scalable with <Precharge Time>	25 50	30 60	35 70	min
T _{PCHGADD}	Pre-charge safety timer "add-on" time range	Maximum value for pre-charge safety timer, thermal, DPM or DPPM loops always active	0		2×T _{CHG}	h
BATTERY-PACK NTC MONITOR						
R _{T1}	Pull-up resistor from thermistor to Internal LDO . I2C selectable	10 k curve 2 NTC	-2%	7.35	2%	kΩ
		100 k curve 1 NTC	-2%	62.5	2%	kΩ
V _{HOT}	High temperature trip point (set to 45°C)	Battery charging		860		mV
V _{HYS(HOT)}	Hysteresis on high trip point (set to 3°C)	Battery charging		50		mV
V _{COLD}	Low temperature trip point (set to 0°C)	Battery charging		1660		mV
V _{HYS(COLD)}	Hysteresis on low trip point (set to 3°C)	Battery charging		50		mV
V _{noNTC}	No NTC detected	NTC error		2000		mV
T _{H_{RMDLY}}	Deglitch time for thermistor detection after thermistor power on		3			ms
t _{DGL(TS)}	Deglitch time, pack temperature fault detection	Battery charging		50		ms

(1) The Battery Charger is DISABLED by default

BATTERY CHARGER (1) (continued)

PARAMETER		TEST CONDITIONS	MIN	TYP	MAX	UNIT
THERMAL REGULATION						
T _{J(REG)}	Temperature regulation limit	If temperature is exceeded, charge current is reduced	115	125	135	°C
T _{J(OFF)}	Charger thermal shutdown			155		°C
T _{J(OFF-HYS)}	Charger thermal shutdown hysteresis			20		°C

DEVICE INFORMATION

PIN ASSIGNMENT (TOP VIEW)

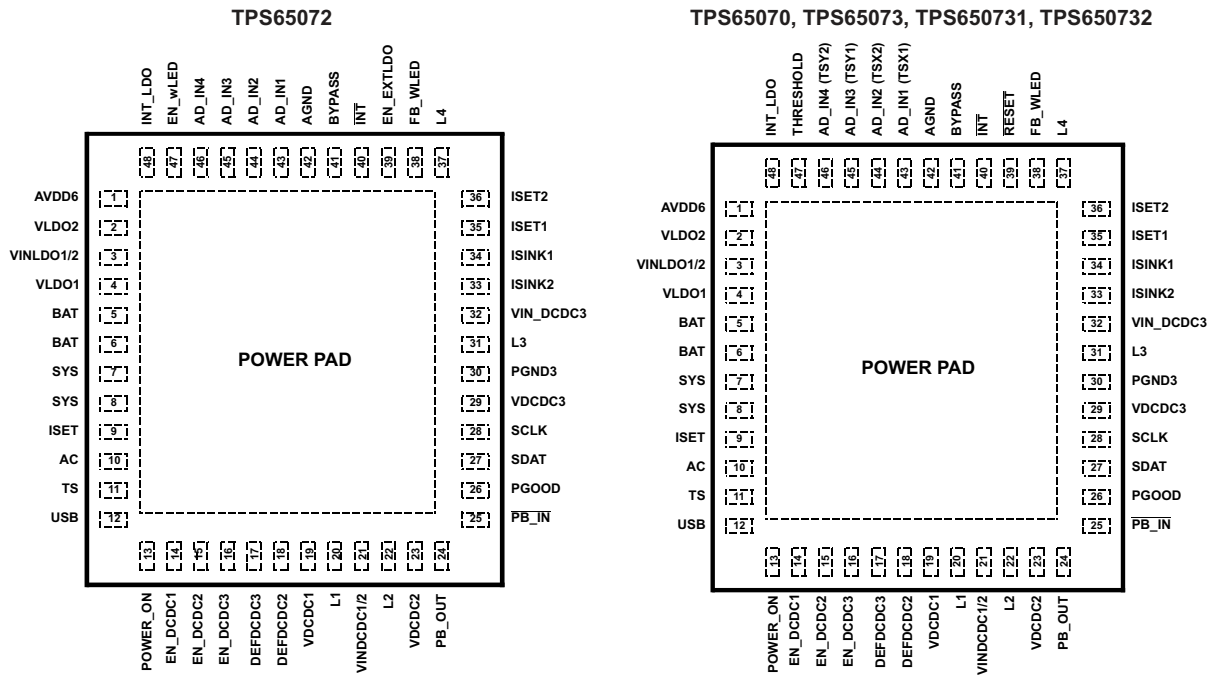

PIN FUNCTIONS

PIN		I/O	DESCRIPTION
NAME	NO.		
CHARGER BLOCK:			
AC	10	I	Input power for power path manager, connect to external DC supply. Connect external 1µF (minimum) to GND
USB	12	I	Input power for power path manager, connect to external voltage from a USB port. Connect external 1µF (minimum) to GND. Default input current limit is 500 mA max
BAT	5,6	O	Charger power stage output, connect to battery. Place a ceramic capacitor of 10µF from these pins to GND
AVDD6	1	O	Internal "always-on"-voltage. Connect a 4.7µF cap from AVDD6 to GND
SYS	7, 8	O	System voltage; output of the power path manager. All voltage regulators are typically powered from this output.
TS	11	I	Temperature sense input. Connect to NTC thermistor to sense battery pack temperature. TPS6507x can be internally programmed to operate with a 10k curve 2 or 100k curve 1 thermistor. To linearize the thermistor response, use a 75k (for the 10k NTC) or a 360k (for the 100k NTC) in parallel with the thermistor. Default setting is 10k NTC
ISET	9	I	Connect a resistor from ISET to GND to set the charge current.
SCLK	28	I	Clock input for the I2C interface.
SDAT	27	I/O	Data line for the I2C interface.
AD_IN1 (TSX1)	43	I	Analog input1 for A/D converter TPS65070, TPS65073, TPS650731, TPS650732 only: Input 1 to the x-plate for the touch screen.

PIN FUNCTIONS (continued)

PIN		I/O	DESCRIPTION
NAME	NO.		
AD_IN2 (TSX2)	44	I	Analog input2 for A/D converter TPS65070, TPS65073, TPS650731, TPS650732 only: Input 2 to the x-plate for the touch screen
AD_IN3 (TSY1)	45	I	Analog input3 for A/D converter TPS65070, TPS65073, TPS650731, TPS650732 only: Input 1 to the y-plate for the touch screen
AD_IN4 (TSY2)	46	I	Analog input4 for A/D converter TPS65070, TPS65073, TPS650731, TPS650732 only: Input 2 to the y-plate for the touch screen
BYPASS	41	O	Connect a 10 μ F bypass cap from this pin to GND. This pin can optionally be used as a reference output (2.26 V). The maximum load on this pin is 0.1mA.
INT_LDO	48	O	Connect a 2.2 μ F bypass cap from this pin to GND. The pin is connected to an internal LDO providing the power for the touch screen controller (TSREF).
$\overline{\text{INT}}$	40	O	Open drain interrupt output. An interrupt can be generated upon: <ul style="list-style-type: none"> • A touch of the touch screen • Voltage applied or removed at pins AC or USB • PB_IN actively pulled low (optionally actively pulled high) The output is actively pulled low if the interrupt is active. The output goes high after the Bit causing the interrupt in register INT has been read. The interrupt sources can be masked in register INT, so no interrupt is generated and pin $\overline{\text{INT}}$ is pulled high with its external pull-up resistor.
CONVERTERS:			
VINDCDC1/2	21	I	Input voltage for DCDC1 and DCDC2 step-down converter. This pin must be connected to the SYS pin.
VDCDC1	19	I	Feedback voltage sense input. For the fixed voltage option, this pin must directly be connected to Vout1, for the adjustable version, this pin is connected to an external resistor divider.
L1	20	O	Switch Pin for DCDC1. Connect to Inductor
EN_DCDC1	14	I	Enable Input for DCDC1, active high
VDCDC2	23	I	Feedback voltage sense input, connect directly to Vout2
DEFDCDC2	18	I	Select Pin of DCDC2 output voltage.
L2	22	O	Switch Pin of DCDC2. Connect to Inductor.
EN_DCDC2	15	I	Enable Input for DCDC2, active high
VINDCDC3	32	I	Input voltage for DCDC3 step-down converter. This pin must be connected to the SYS pin.
VDCDC3	29	I	Feedback voltage sense input, connect directly to Vout3
DEFDCDC3	17	I	Select Pin of DCDC3 output voltage.
L3	31	O	Switch Pin of DCDC3. Connect to Inductor.
EN_DCDC3	16	I	Enable Input for DCDC3, active high
PGND3	30		Power GND for DCDC3. Connect to PGND (PowerPAD)
AGND	42		Analog GND, connect to PGND (PowerPAD)
VINLDO1/2	3	I	Input voltage for LDO1 and LDO2
VLDO1	4	O	Output voltage of LDO1
VLDO2	2	O	Output voltage of LDO2
L4	37	I	Switch Pin of the white LED (wLED) boost converter. Connect to Inductor and rectifier diode.
FB_wLED	38	I	Feedback input for the boost converter's output voltage.
Iset1 (AD_IN6)	35	I	Connect a resistor from this pin to GND to set the full scale current for Isink1 and Isink2 with Bit Current Level in register WLED_CTRL0 set to 1. Analog input6 for the A/D converter.
Iset2 (AD_IN7)	36	I	Connect a resistor from this pin to GND to set the full scale current for Isink1 and Isink2 with Bit Current Level in register WLED_CTRL0 set to 0. Analog input7 for the A/D converter.
Isink1	34	I	Input to the current sink 1. Connect the cathode of the LEDs to this pin.
Isink2	33	I	Input to the current sink 2. Connect the cathode of the LEDs to this pin.
$\overline{\text{PB_IN}}$	25	I	Enable input for TPS6507x. When pulled LOW, the DCDC converters and LDOs start with the sequencing as programmed internally. Internal 50k Ω pull-up resistor to AVDD6

PIN FUNCTIONS (continued)

PIN		I/O	DESCRIPTION
NAME	NO.		
POWER_ON	13	I	Power_ON input for the internal state machine. After $\overline{\text{PB_IN}}$ was pulled LOW to turn on the TPS6507x, the POWER_ON pin needs to be pulled HIGH by the application processor to keep the system in ON-state when $\overline{\text{PB_IN}}$ is released HIGH. If POWER_ON is released LOW, the DCDC converters and LDOs will turn off when $\overline{\text{PB_IN}}$ is HIGH.
PB_OUT	24	O	Open drain output. This pin is driven by the status of the /PB_IN input (after debounce). PB_OUT=LOW if $\overline{\text{PB_IN}}$ =LOW
PGOOD	26	O	Open drain power good output. The delay time equals the setting for $\overline{\text{Reset}}$. The pin will go low depending on the setting in register PGOODMASK. Optionally it is also driven LOW for 0.5ms when PB_IN is pulled LOW for >15s.
THRESHOLD	47	I	TPS65070, TPS65073, TPS650731, TPS650732:Input for the reset comparator. $\overline{\text{RESET}}$ will be LOW if this voltage drops below 1V.
$\overline{\text{RESET}}$	39	O	Open drain active low reset output, reset delay time. The status depends on the voltage applied at THRESHOLD.
PowerPAD™			Power ground connection for the PMU. Connect to GND

Functional Block Diagram

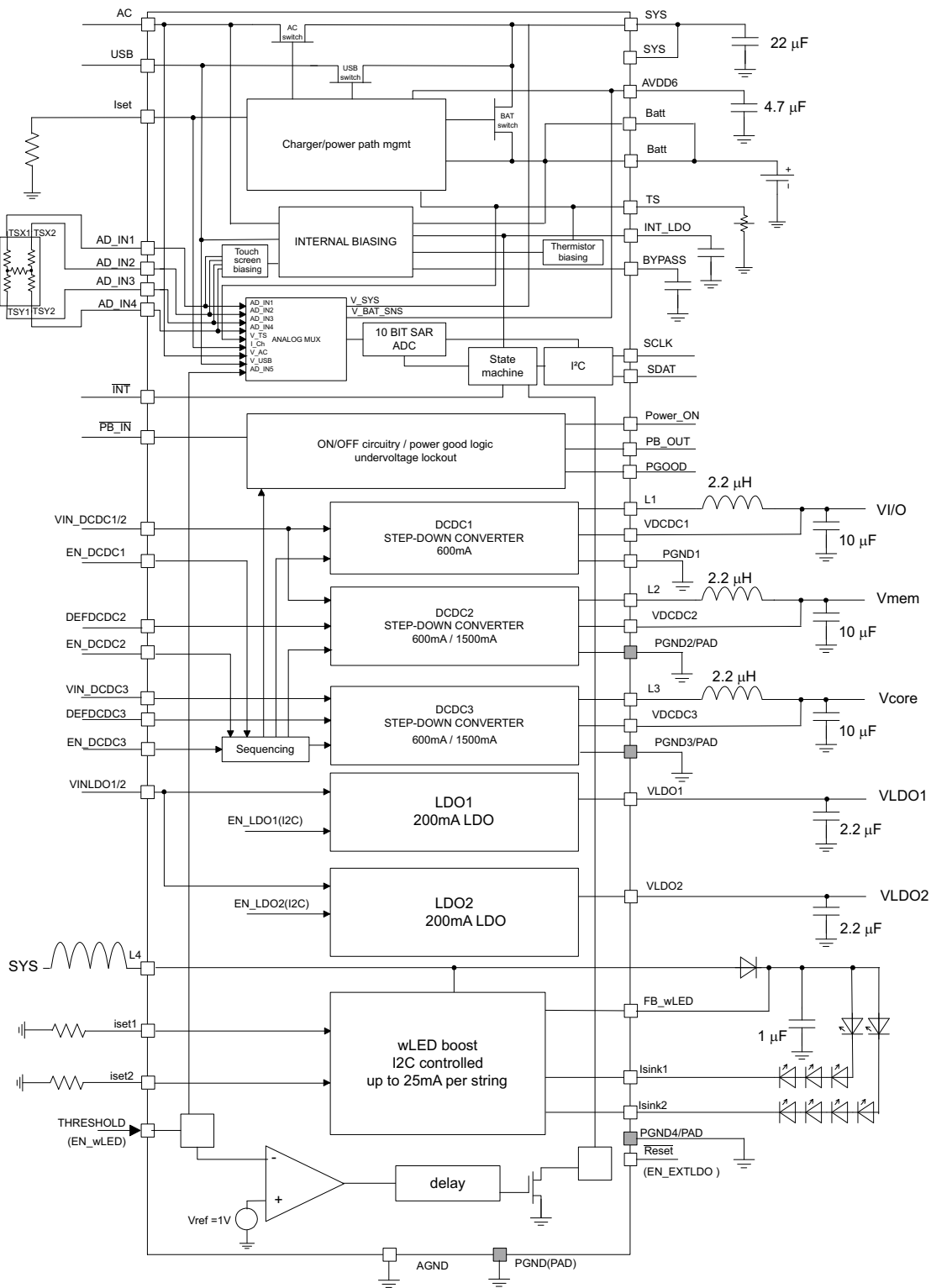

PARAMETER MEASUREMENT INFORMATION

The data sheet graphs were taken on the evaluation module (EVM). Please refer to the EVM user's guide ([SLVU291](#)) for the setup information.

TYPICAL CHARACTERISTICS

TABLE OF GRAPHS

		FIGURE
Efficiency DCDC1 vs Load current / PWM mode	$V_O = 3.3V$; $V_I = 3.0V, 3.6V, 4.2V, 5V$	1
Efficiency DCDC1 vs Load current / PFM mode	$V_O = 3.3V$; $V_I = 3.0V, 3.6V, 4.2V, 5V$	2
Efficiency DCDC2 vs Load current / PWM mode up to 1.5A	$V_O = 2.5V$; $V_I = 3.0V, 3.6V, 4.2V, 5V$	3
Efficiency DCDC2 vs Load current / PFM mode up to 1.5A	$V_O = 2.5V$; $V_I = 3.0V, 3.6V, 4.2V, 5V$	4
Efficiency DCDC2 vs Load current / PWM mode up to 1.5A	$V_O = 1.8V$; $V_I = 3.0V, 3.6V, 4.2V, 5V$	5
Efficiency DCDC2 vs Load current / PFM mode up to 1.5A	$V_O = 1.8V$; $V_I = 3.0V, 3.6V, 4.2V, 5V$	6
Efficiency DCDC3 vs Load current / PWM mode up to 1.5A	$V_O = 1.2V$; $V_I = 3.0V, 3.6V, 4.2V, 5V$	7
Efficiency DCDC3 vs Load current / PFM mode up to 1.5A	$V_O = 1.2V$; $V_I = 3.0V, 3.6V, 4.2V, 5V$	8
Efficiency DCDC3 vs Load current / PWM mode up to 1.5A	$V_O = 1.0V$; $V_I = 3.0V, 3.6V, 4.2V, 5V$	9
Efficiency DCDC3 vs Load current / PFM mode up to 1.5A	$V_O = 1.0V$; $V_I = 3.0V, 3.6V, 4.2V, 5V$	10
Load transient response converter 1	Scope plot; $I_O = 60mA$ to $540mA$; $V_O = 3.3V$; $V_I = 3.6V$	11
Load transient response converter 2	Scope plot; $I_O = 150mA$ to $1350mA$; $V_O = 1.8V$; $V_I = 3.6V$	12
Load transient response converter 3	Scope plot; $I_O = 150mA$ to $1350mA$; $V_O = 1.2V$; $V_I = 3.6V$	13
Line transient response converter 1	Scope plot; $V_O = 3.3$; $V_I = 3.6V$ to $5V$ to $3.6V$; $I_O = 600mA$	14
Line transient response converter 2	Scope plot; $V_O = 1.8$; $V_I = 3.6V$ to $5V$ to $3.6V$; $I_O = 600mA$	15
Line transient response converter 3	Scope plot; $V_O = 1.2V$; $V_I = 3.6V$ to $5V$ to $3.6V$; $I_O = 600mA$	16
Output voltage ripple and inductor current converter 2; PWM Mode	Scope plot; $V_I = 3.6V$; $V_O = 1.8V$; $I_O = 10mA$	17
Output voltage ripple and inductor current converter 2; PFM Mode	Scope plot; $V_I = 3.6V$; $V_O = 1.8V$; $I_O = 10mA$	18
Startup DCDC1, DCDC2 and DCDC3, LDO1, LDO2	Scope plot	19
Load transient response LDO1	Scope plot; $V_O = 1.2V$; $V_I = 3.6V$	20
Line transient response LDO1	Scope plot	21
K_{SET} vs R_{ISET}		22
wLED efficiency vs duty cycle	2 x 6LEDs ($V_{LED} = 19.2V$); $I_O = 2 \times 20mA$	23
wLED efficiency vs input voltage	2 x 6LEDs ($V_{LED} = 19.2V$); $I_O = 2 \times 20mA$	24

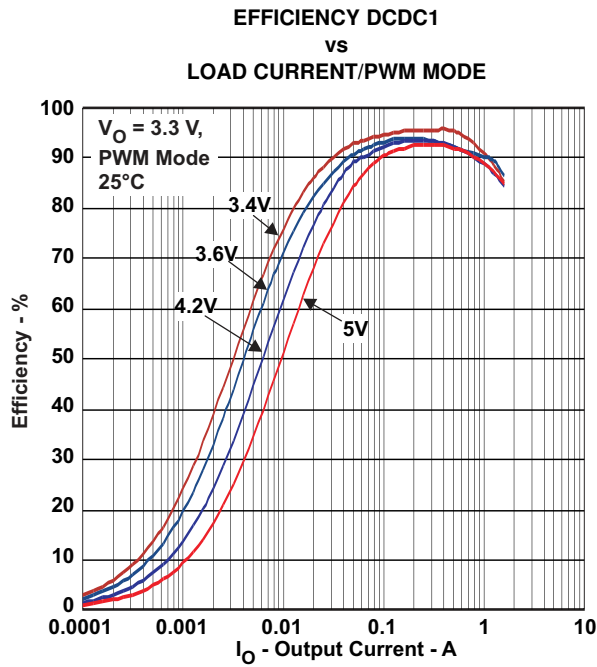

Figure 1.

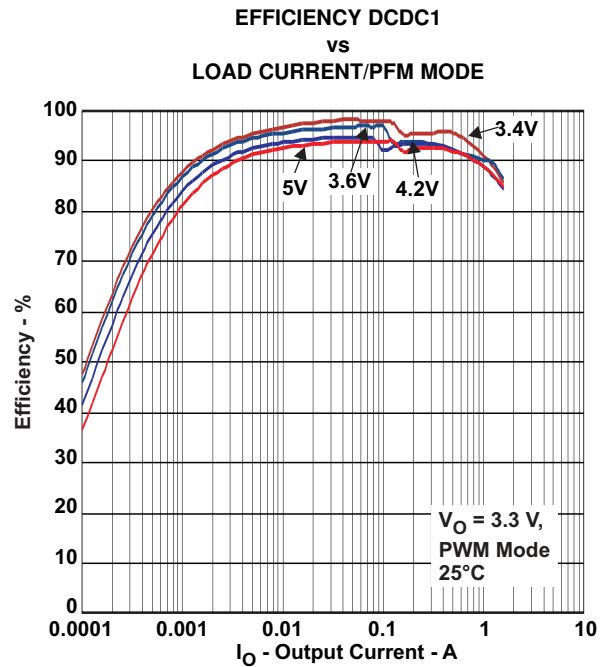

Figure 2.

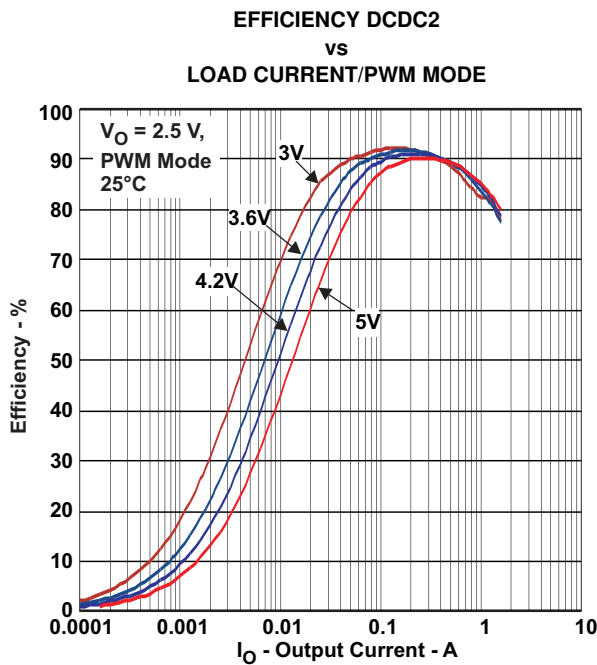

Figure 3.

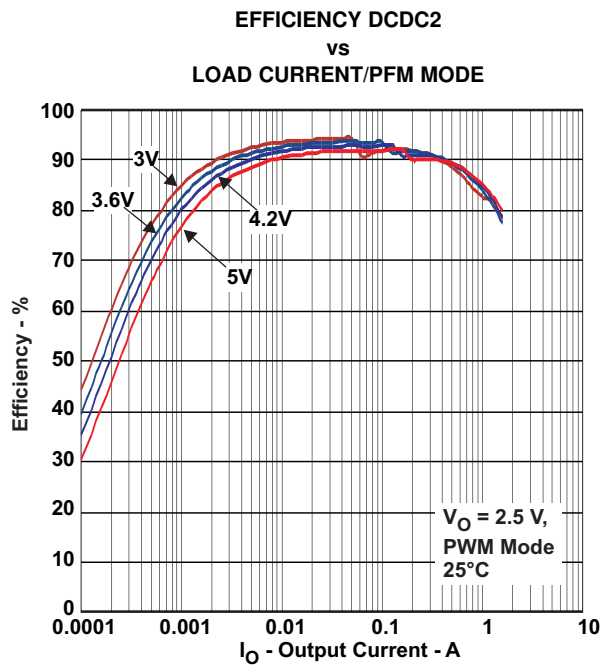

Figure 4.

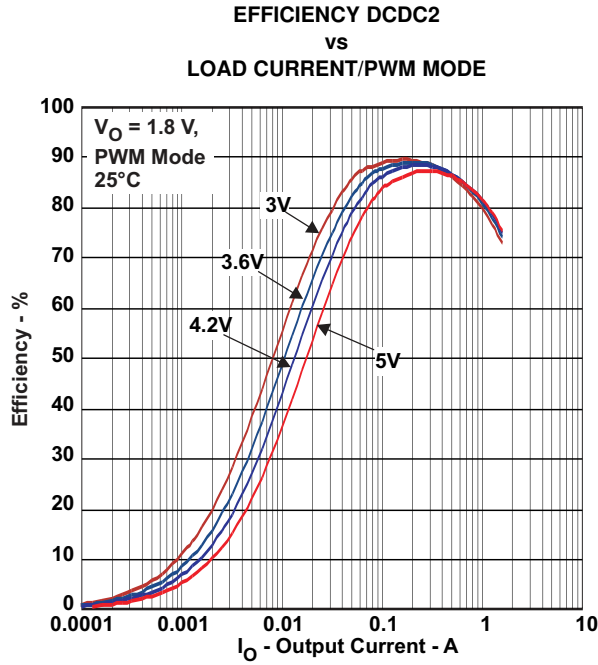

Figure 5.

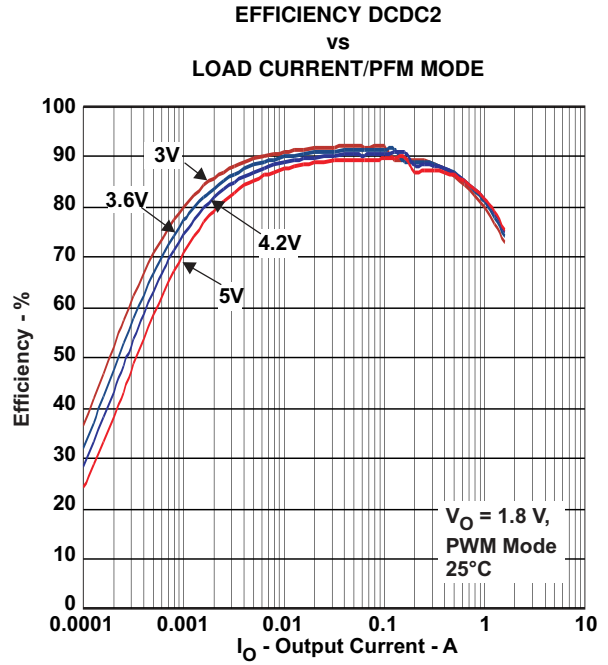

Figure 6.

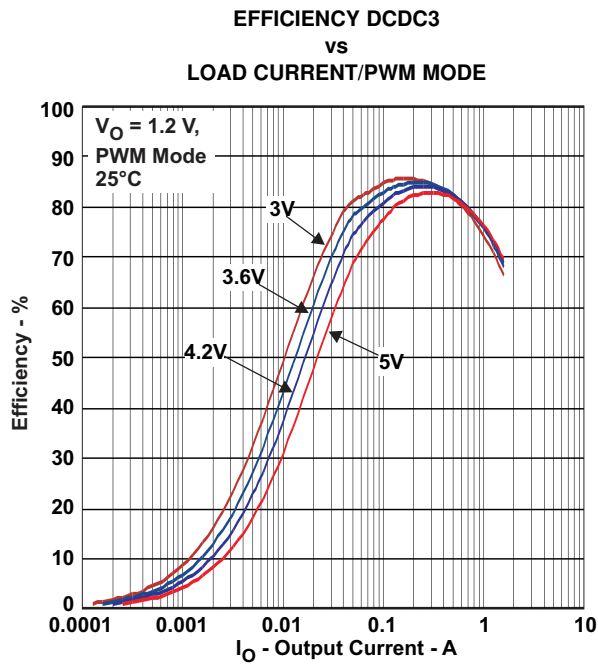

Figure 7.

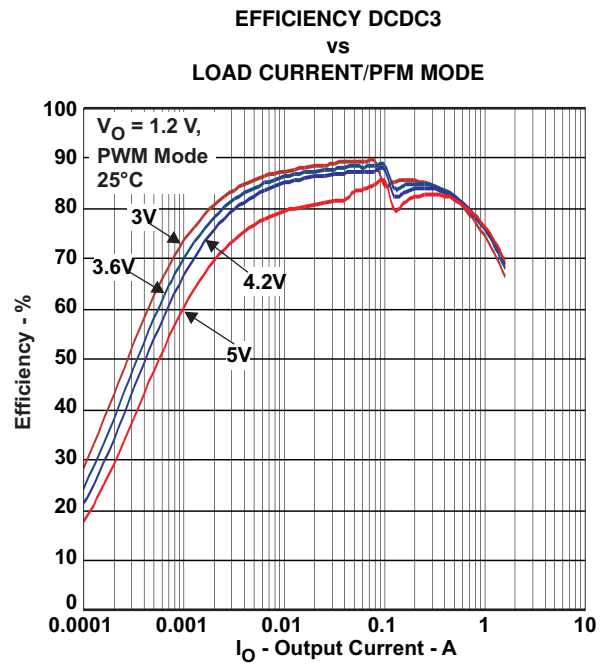

Figure 8.

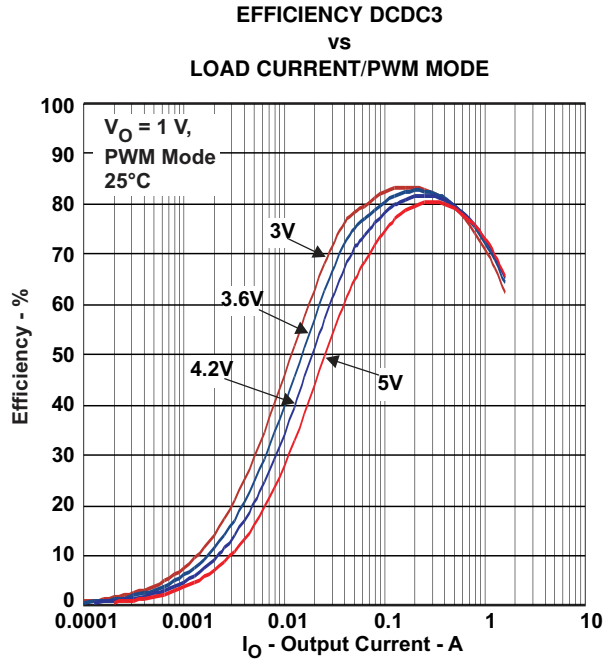

Figure 9.

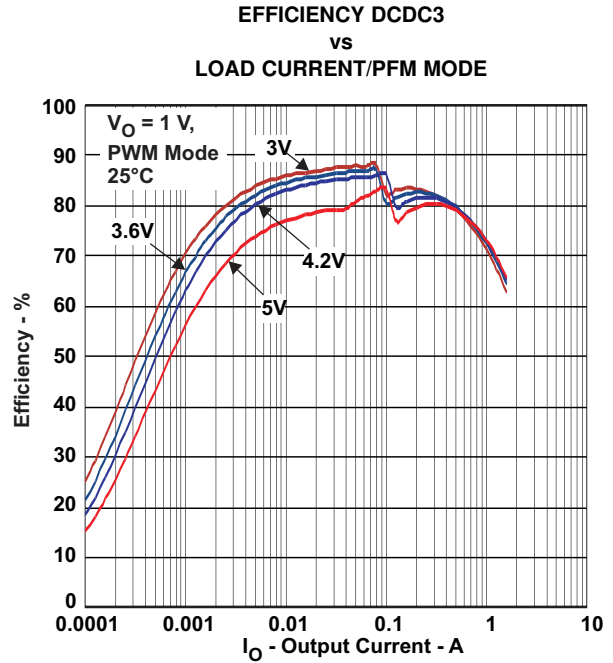

Figure 10.

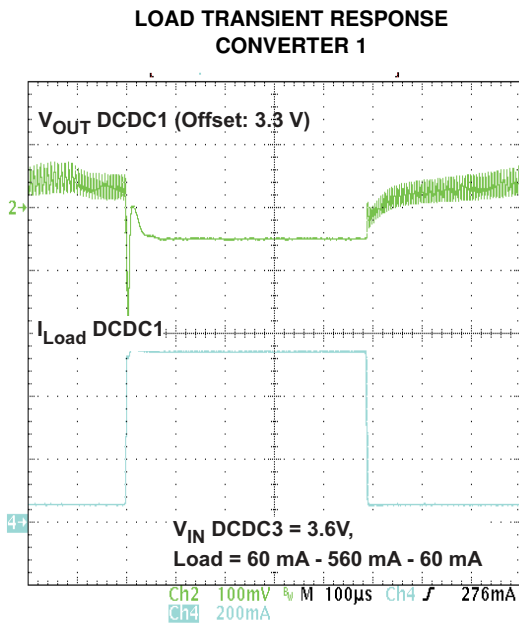

Figure 11.

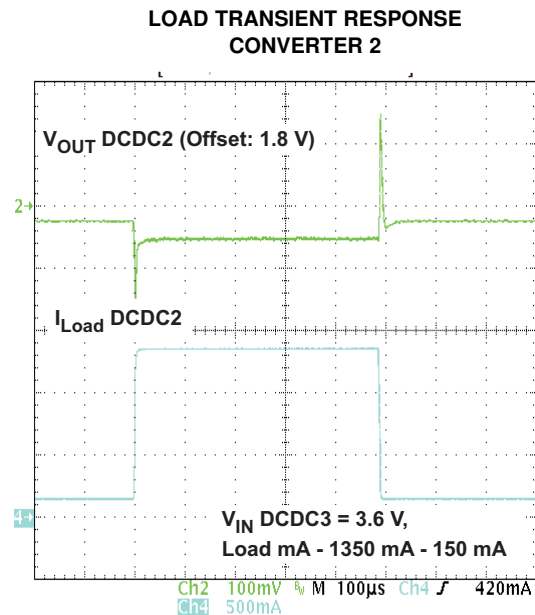

Figure 12.

LOAD TRANSIENT RESPONSE
CONVERTER 3

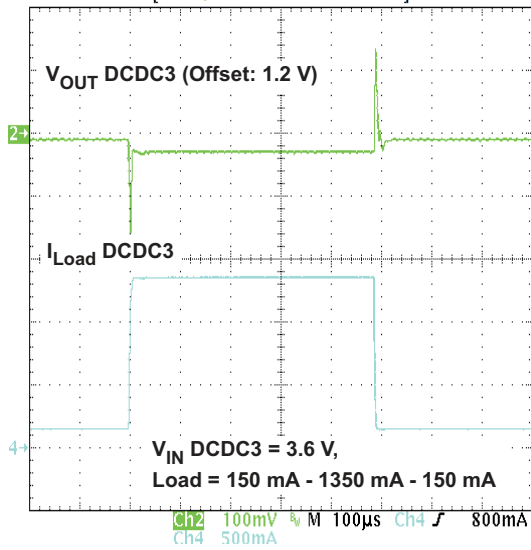

Figure 13.

LINE TRANSIENT RESPONSE
CONVERTER 1

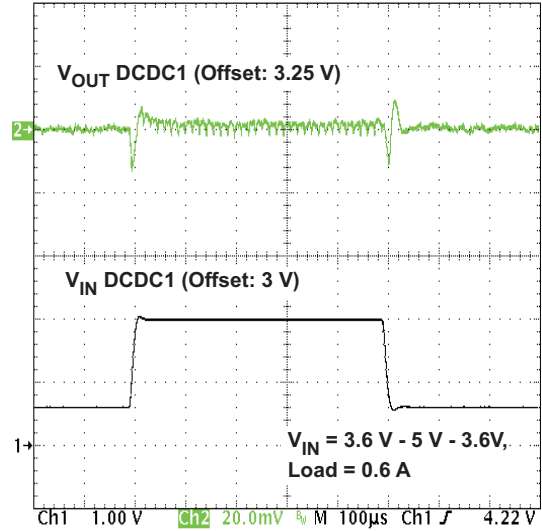

Figure 14.

LINE TRANSIENT RESPONSE
CONVERTER 2

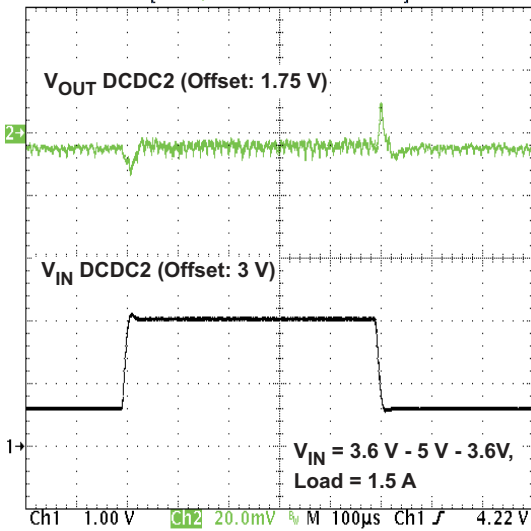

Figure 15.

LINE TRANSIENT RESPONSE
CONVERTER 3

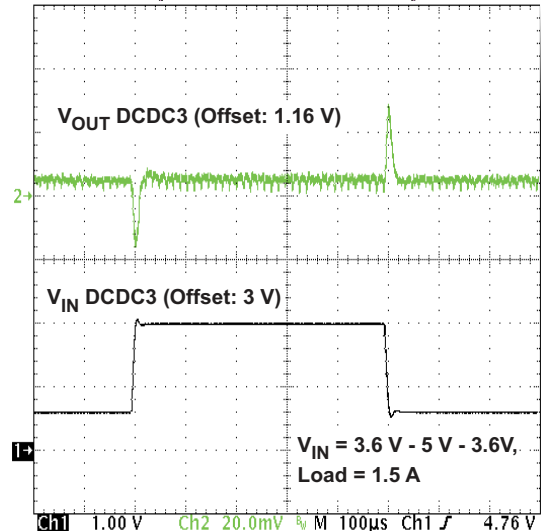

Figure 16.

OUTPUT VOLTAGE RIPPLE AND INDUCTOR CURRENT
CONVERTER 2 – PWM MODE

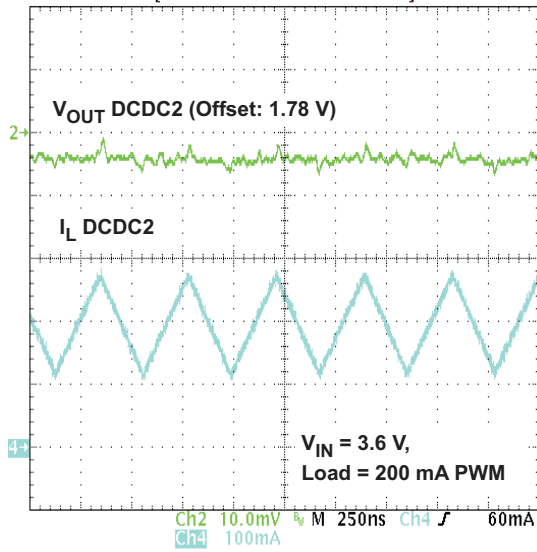

Figure 17.

OUTPUT VOLTAGE RIPPLE AND INDUCTOR CURRENT
CONVERTER 2 – PFM MODE

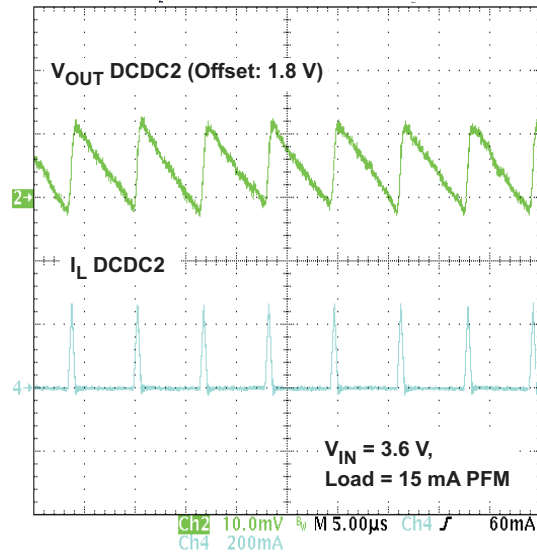

Figure 18.

STARTUP DCDC1, DCDC2, AND DCDC3,
LDO1, LDO2

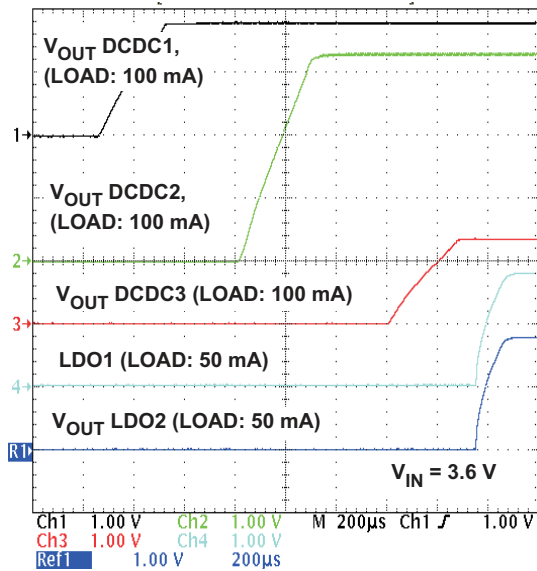

Figure 19.

LOAD TRANSIENT RESPONSE LDO1

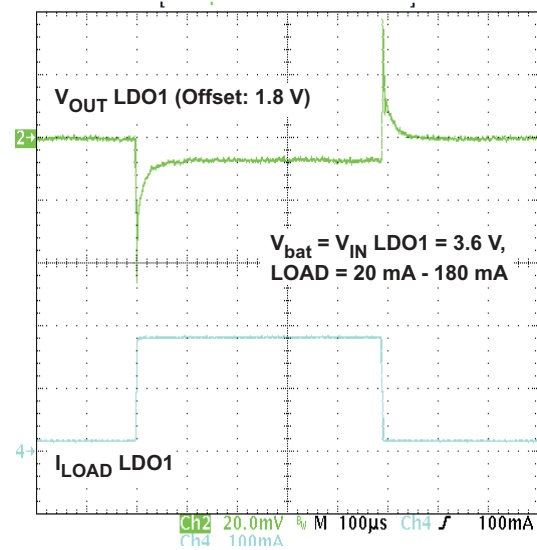

Figure 20.

LINE TRANSIENT RESPONSE LDO1

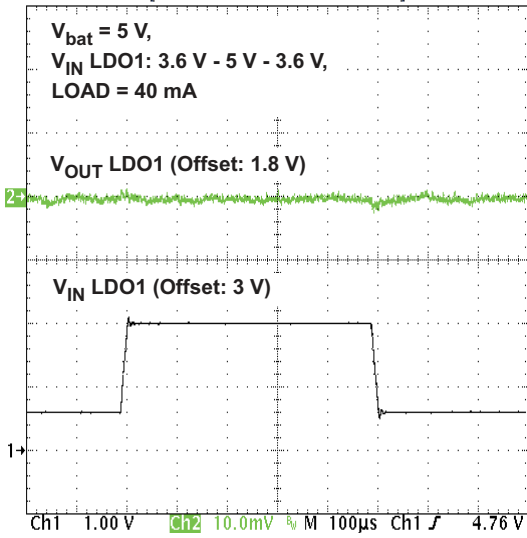

Figure 21.

K_{SET}
vs
 R_{ISET}

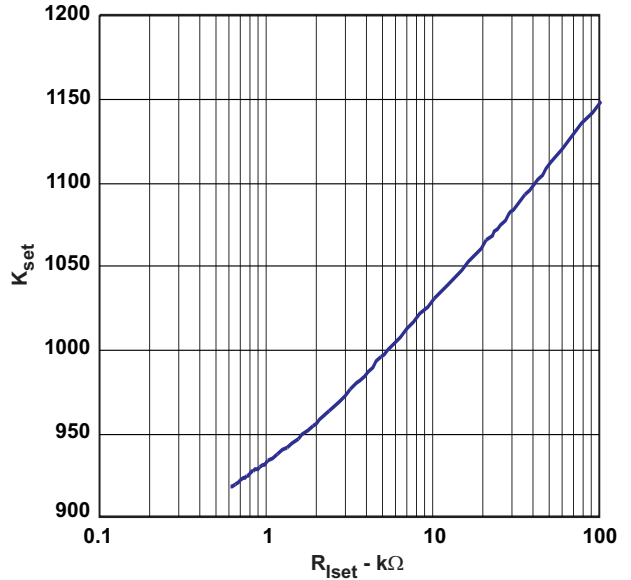

Figure 22.

wLED EFFICIENCY
vs
Duty Cycle

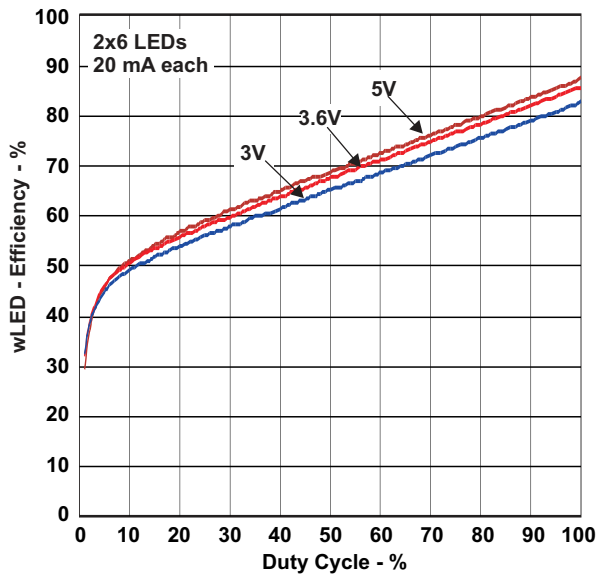

Figure 23.

wLED EFFICIENCY
vs
 V_{IN}

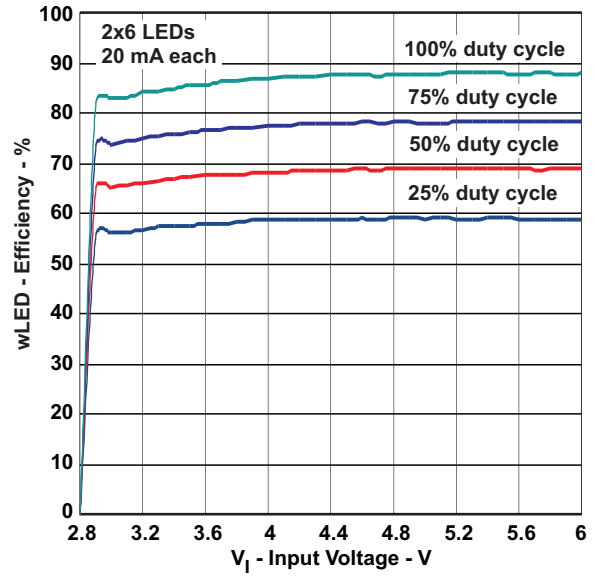

Figure 24.

DETAILED DESCRIPTION

BATTERY CHARGER AND POWER PATH

The integrate a Li-ion linear charger and system power path management targeted at space-limited portable applications. The power the system while simultaneously and independently charging the battery. This feature reduces the number of charge and discharge cycles on the battery, allows for proper charge termination and enables the system to run with a defective or absent battery pack. It also allows instant system turn-on even with a totally discharged battery. The input power source for charging the battery and running the system can be an AC adapter or a USB port. The power-path management feature automatically reduces the charging current if the system load increases. The power-path architecture also permits the battery to supplement the system current requirements when the adapter cannot deliver the peak system currents.

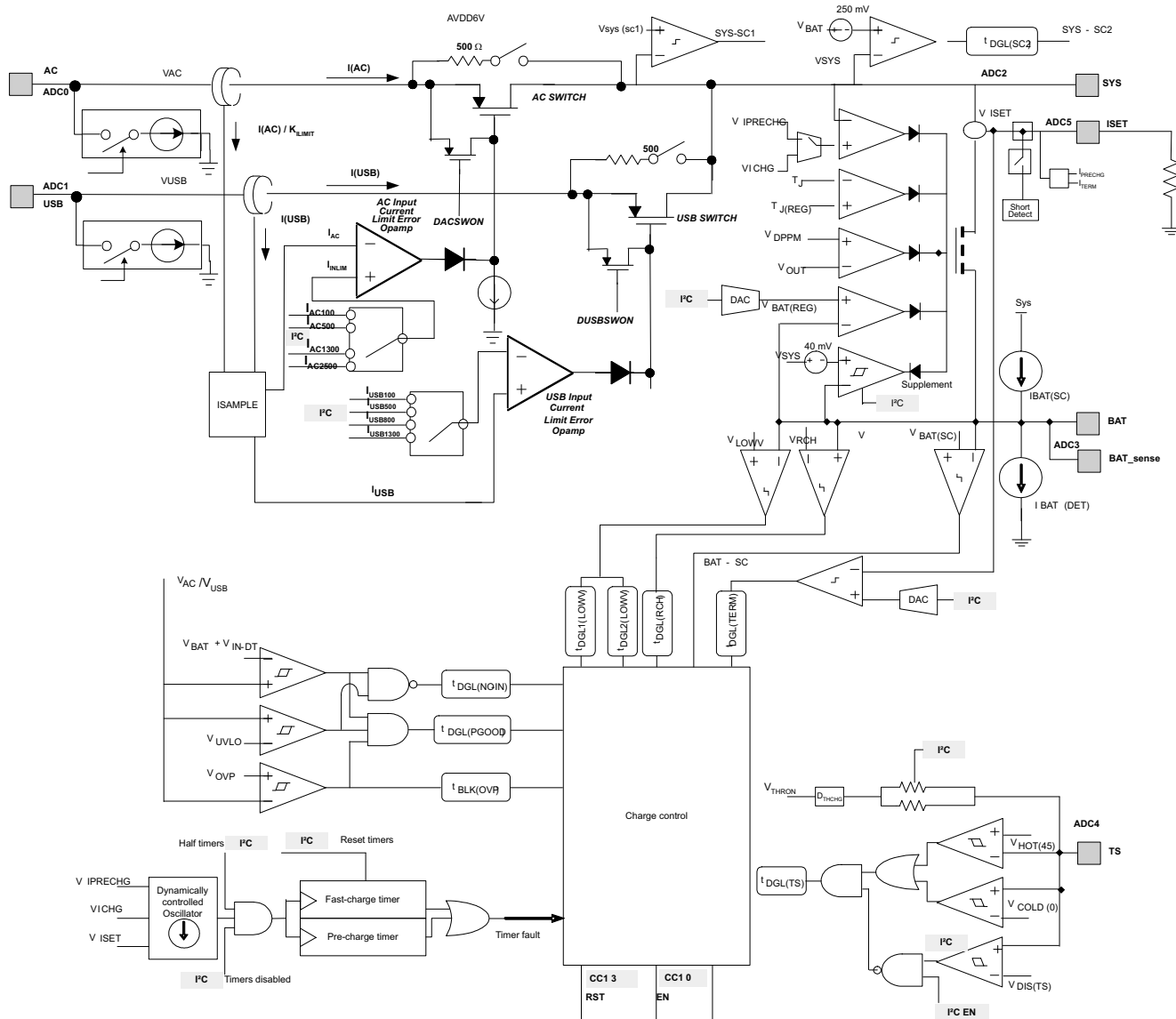

Figure 25. Charger Block Diagram

POWER DOWN

The charger remains in a power down mode when the input voltage at the AC or USB pin is below the under-voltage lockout threshold V_{UVLO} . During the power down mode the host commands at the control pins are not interpreted.

POWER-ON RESET

The charger resets when the input voltage at the AC or USB pin enters the valid range between V_{UVLO} and V_{OVLO} . All internal timers and other circuit blocks are reset. The device then waits for a time period $T_{DGL(PGOOD)}$, after which CHARGER ACTIVE Bit indicates the input power status, and the Iset pin is interpreted.

POWER-PATH MANAGEMENT

There are two inputs to the power path called AC and USB. Both inputs support the same voltage rating but are typically set to a different current limit with AC being at the higher limit and USB at the lower. If voltage is applied at both inputs and both are enabled in register PPATH1 (default setting), AC will be preferred over USB. In this case, the device is only powered from AC and there is no current from USB. If voltage at AC is removed, the USB input will become and is powered from USB. The current at the input pin AC or USB of the power path manager is shared between charging the battery and powering the system load on the SYS pin. Priority is given to the system load. The input current is monitored continuously. If the sum of the charging and system load currents exceeds the preset maximum input current (programmed internally by I2C), the charging current is reduced automatically. See the electrical characteristics or the register description for the default current limit on AC and USB for the different family members.

Figure 26 illustrates what happens in an example case where the battery fast-charge current is set to 500mA, the input current limit is set at 900mA and the system load varies from 0 to 750mA.

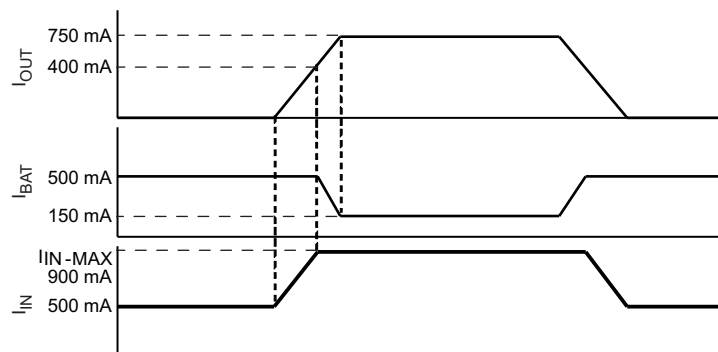

Figure 26. Power Path Functionality

SYS Output

The SYS pin is the output of the power path. When is turned off and there is no voltage at AC or USB, the SYS output is disconnected internally from the battery. When is turned on by pulling $PB_IN = LOW$, the voltage at SYS will ramp with a soft-start. During soft start, the voltage at SYS is ramped with a 30mA current source until the voltage reached 1.8V. During the soft start, the SYS pin must not be loaded by an external load.

BATTERY CHARGING

When Bit CHARGER ENABLE in register CHGCONFIG1 is set to 1, battery charging can begin. First, the device checks for a short-circuit on the BAT pin: $I_{BAT(SC)}$ is turned on till the voltage on the BAT pin rises above $V_{BAT(SC)}$. If conditions are safe, it proceeds to charge the battery.

The battery is charged in three phases: conditioning pre-charge, constant current fast charge (current regulation) and a constant voltage tapering-off (voltage regulation). In all charge phases, an internal control loop monitors the IC junction temperature and reduces the charge current if the internal temperature threshold is exceeded.

Figure 27 shows what happens in each of the three phases:

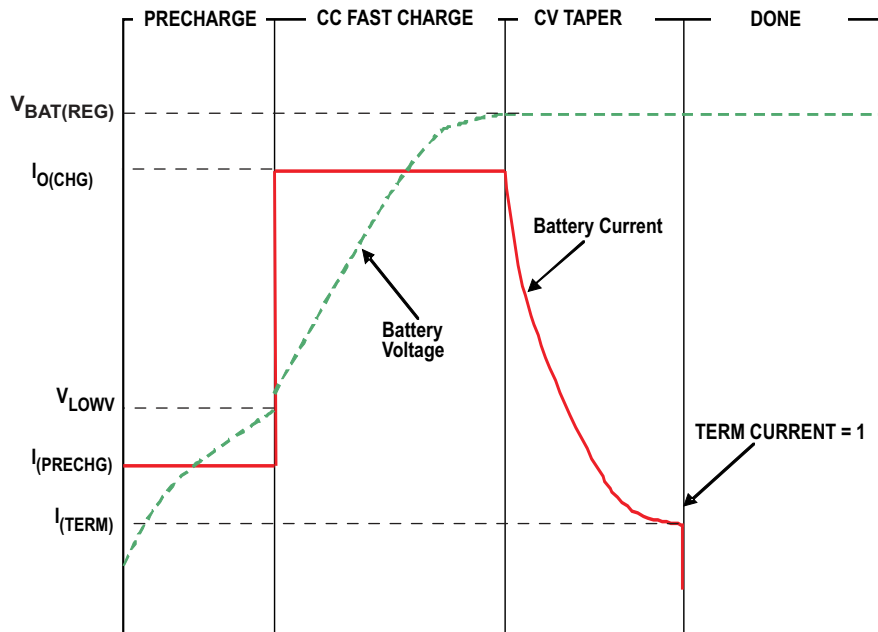
Figure 27. Battery Charge

In the pre-charge phase, the battery is charged at a current of I_{PRECHG} . The battery voltage starts rising. Once the battery voltage crosses the V_{LOWV} threshold, the battery is charged at a current of I_{CHG} . The battery voltage continues to rise. When the battery voltage reaches $V_{BAT(REG)}$, the battery is held at a constant value of $V_{BAT(REG)}$. The battery current now decreases as the battery approaches full charge. When the battery current reaches I_{TERM} , the TERM CURRENT flag in register CHGCONFIG0 indicates charging done by going high.

Note that termination detection is disabled whenever the charge rate is reduced from the set point because of the actions of the thermal loop, the DPM loop or the V_{IN-LOW} loop.

The value of the fast-charge current is set by the resistor connected from the ISET pin to GND, and is given by the equation

$$I_{CHG} = K_{ISET} / R_{ISET} \quad (1)$$

$$R_{ISET} = K_{ISET} / I_{CHG} \quad (2)$$

Note that if I_{CHG} is programmed as greater than the input current limit, the battery will not charge at the rate of I_{CHG} , but at the slower rate of I_{IN-MAX} (minus the load current on the OUT pin, if any). In this case, the charger timers will be slowed down by 2x whenever the thermal loop or DPPM is active.

I-PRECHARGE:

The value for the pre-charge current is fixed to a factor of 0.1 of the fast charge current (full scale current) programmed by the external resistor R_{set}

I_TERM:

The value for the termination current threshold can be set in register CHGCONFIG3 using Bits TERMINATION CURRENT FACTOR 0 and TERMINATION CURRENT FACTOR 1. The termination current is pre-set to a factor of 0.1 of the fast charge current programmed by the external resistor R_{set} .

Battery Detection and Recharge:

Whenever the battery voltage falls below V_{RCH} ($V_{set}-100mV$), a check is performed to see whether the battery has been removed: current $I_{BAT(DET)}$ is pulled from the battery for a duration t_{DET} . If the voltage on the BAT pin remains above V_{LOWV} , it indicates that the battery is still connected. If the charger is enabled by Bit CHARGER ENABLE in register CHGCONFIG1 set to 1, the charger is turned on again to top up the battery.

If the BAT pin voltage falls below V_{LOWV} in the battery detection test, it indicates that the battery has been removed. The device then checks for battery insertion: it turns on FET Q2 and sources I_{PRECHG} out of the BAT pin for duration t_{DET} . If the voltage does not rise above V_{RCH} , it indicates that a battery has been inserted, and a new charge cycle can begin. If, however, the voltage does rise above V_{RCH} , it is possible that a fully charged battery has been inserted. To check for this, $I_{BAT(DET)}$ is pulled from the battery for t_{DET} : if the voltage falls below V_{LOWV} , a battery is not present. The device keeps looking for the presence of a battery.

Charge Termination On/Off:

Charge termination can be disabled by setting the Bit CHARGE TERMINATION ON/OFF in register CHGCONFIG1 to logic high. When termination is disabled, the device goes through the pre-charge, fast-charge and CV phases, then remains in the CV phase – the charger behaves like an LDO with an output voltage equal to $V_{BAT(REG)}$, able to source current up to I_{CHG} or I_{IN-MAX} , whichever is lesser. Battery detection is not performed.

Timers:

The charger in has internal safety timers for the pre-charge and fast-charge phases to prevent potential damage to either the battery or the system. The default values for the timers can be changed in registers CHGCONFIG1 and CHGCONFIG3. The timers can be disabled by clearing Bit SAFETY TIMERS ENABLE in register CHGCONFIG1. (Note that the timers are disabled when termination is disabled: Bit CHARGE TERMINATION ON/OFF in register CHGCONFIG1 =1).

Dynamic Timer Function:

The following events can reduce the charging current and increase the timer durations in the fast charge phase:

1. The system load current increases, and the DPPM loop reduces the available charging current
2. The input current is reduced because the input voltage has fallen to V_{IN-LOW}
3. The device has entered thermal regulation because the IC junction temperature has exceeded $T_{J(REG)}$

In each of these events, the internal timers are slowed down proportionately to the reduction in charging current. Note also that whenever any of these events occurs, termination detection is disabled.

A modified charge cycle with the thermal loop active is shown in [Figure 28](#).

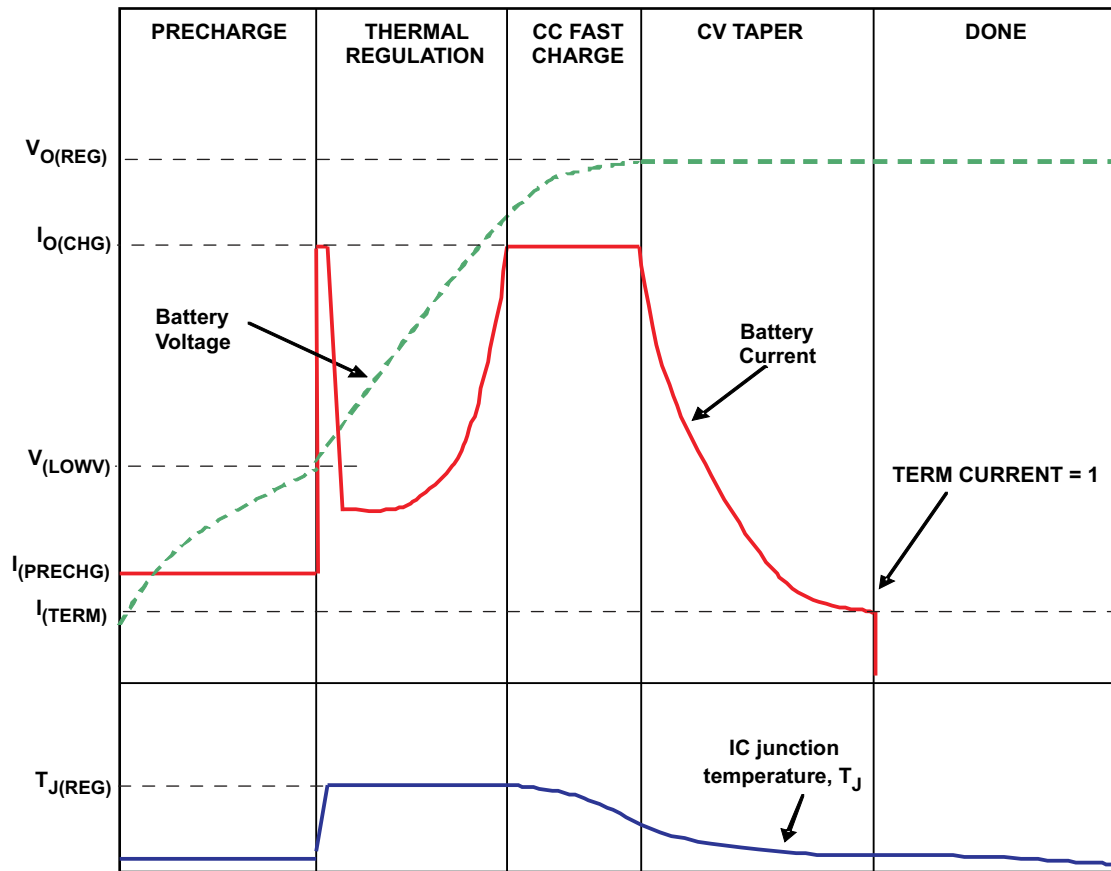
Figure 28. Thermal Loop
Timer Fault:

The following events generate a fault status:

1. If the battery voltage does not exceed V_{LOWV} in time t_{PRECHG} during pre-charging
2. If the battery current does not reach I_{TERM} in time t_{MAXCH} in fast charge (measured from beginning of fast charge).

The fault status is indicated by Bits CHG TIMEOUT or PRECHG TIMEOUT in register CHGCONFIG0 set to 1.

BATTERY PACK TEMPERATURE MONITORING

The device has a TS pin that connects to the NTC resistor in the battery pack. During charging, if the resistance of the NTC indicates that the battery is operating outside the limits of safe operation, charging is turned off. All timers maintain their values. When the battery pack temperature returns to a safe value, charging is resumed, and the timers are also turned back on.

Battery pack temperature sensing is disabled when termination is disabled and the voltage on the TS pin is higher than $V_{DIS(TS)}$ (caused by absence of pack and thus absence of NTC).

The default for the NTC is defined in register CHGCONFIG1 with Bit SENSOR TYPE as a 10k curve 2 NTC. The sensor can be changed to a 100k curve 1 NTC by setting the Bit to 0.

There needs to be a resistor in parallel to the NTC for linearization of the temperature curve. The value for the resistor is given in the table below:

Sensor type	resistor value in parallel to the NTC
10K curve 2	75k
100k curve 1	360k

BATTERY CHARGER STATE DIAGRAM

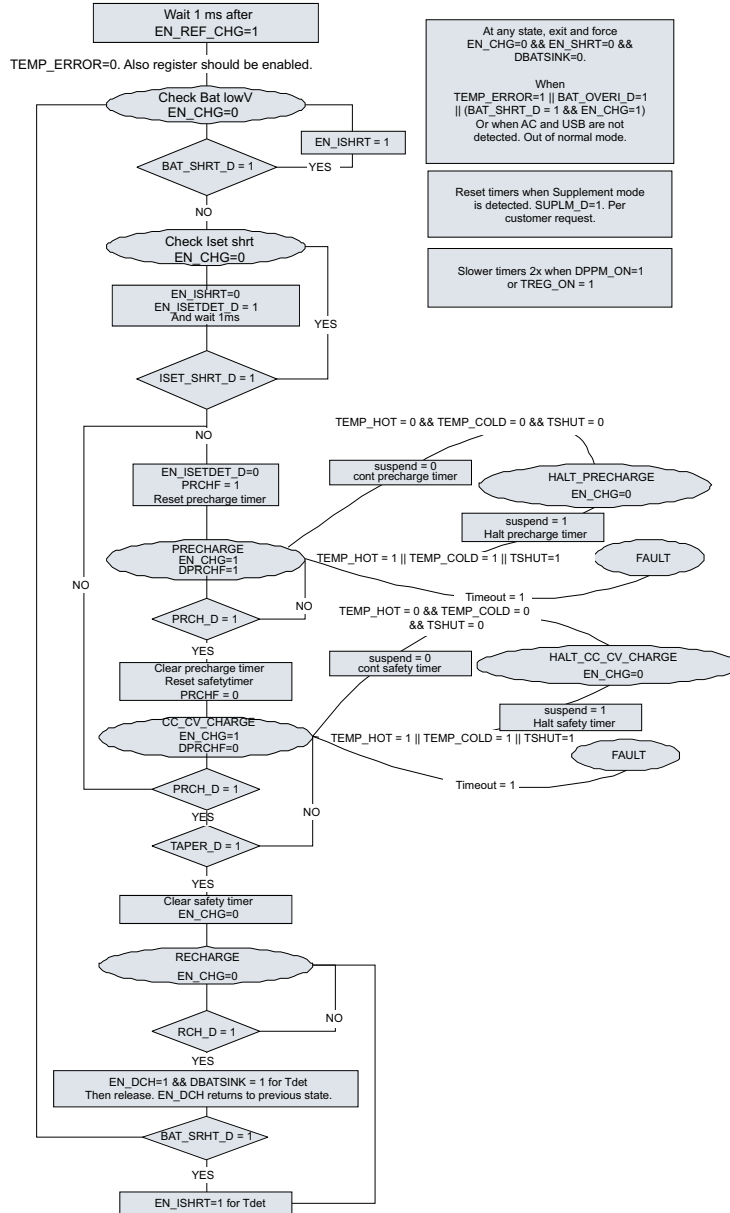

Figure 29. Charger State Machine

DCDC CONVERTERS AND LDOs

OPERATION

The step down converters operate with typically 2.25MHz fixed frequency pulse width modulation (PWM) at moderate to heavy load currents. At light load currents the converter automatically enters Power Save Mode and operates in Pulse Frequency Modulation (PFM) .

During PWM operation the converter use a unique fast response voltage mode controller scheme with input

voltage feed-forward to achieve good line and load regulation allowing the use of small ceramic input and output capacitors. At the beginning of each clock cycle initiated by the clock signal, the High Side MOSFET switch is turned on. The current flows now from the input capacitor via the High Side MOSFET switch through the inductor to the output capacitor and load. During this phase, the current ramps up until the PWM comparator trips and the control logic will turn off the switch. The current limit comparator will also turn off the switch in case the current limit of the High Side MOSFET switch is exceeded. After a dead time preventing shoot through current, the Low Side MOSFET rectifier is turned on and the inductor current will ramp down. The current flows now from the inductor to the output capacitor and to the load. It returns back to the inductor through the Low Side MOSFET rectifier.

The next cycle will be initiated by the clock signal again turning off the Low Side MOSFET rectifier and turning on the High Side MOSFET switch.

The DC-DC converters operate synchronized to each other, with converter 1 as the master. A phase shift of 180° between converter 1 and converter 2 decreases the input RMS current. Therefore smaller input capacitors can be used. Converter 3 operates in phase with converter 1.

DCDC1 Converter

The output voltage for converter 1 is set to a fixed voltage internally in register DEFDCDC1. The voltage can be changed using the I2C interface. The default settings are given in [Table 1](#).

Optionally the voltage can be set by an external resistor divider if configured in register DEFDCDC1.

DCDC2 Converter

The VDCDC2 pin must be directly connected to the DCDC2 converter's output voltage. The DCDC2 converter's output voltage can be selected via the DEFDCDC2 pin or optionally by changing the values in registers DEFDCDC2_LOW and DEFDCDC2_HIGH. If pin DEFDCDC2 is pulled to GND, register DEFDCDC2_LOW defines the output voltage. If the pin DEFDCDC2 is driven HIGH, register DEFDCDC2_HIGH defines the output voltage. Therefore, the voltage can either be changed between two values by toggling pin DEFDCDC2 or by changing the register values. Default voltages for DCDC1, DCDC2 and DCDC3 are:

Table 1. Default Voltages

	DCDC1	DCDC2		DCDC3	
		DEFDCDC2=LOW	DEFDCDC2=HIGH	DEFDCDC3=LOW	DEFDCDC3=HIGH

DCDC3 Converter

The VDCDC3 pin must be directly connected to the DCDC3 converter's output voltage. The DCDC3 converter's output voltage can be selected via the DEFDCDC3 pin or optionally by changing the values in registers DEFDCDC3_LOW and DEFDCDC3_HIGH. If pin DEFDCDC3 is pulled to GND, register DEFDCDC3_LOW defines the output voltage. If the pin DEFDCDC3 is driven HIGH, register DEFDCDC3_HIGH defines the output voltage. Therefore, the voltage can either be changed between two values by toggling pin DEFDCDC3 or by changing the register values.

LDO2 can optionally be forced to follow the voltage defined for DCDC3 by setting Bit LDO2 TRACKING in register DEF LDO2.

POWER SAVE MODE

The Power Save Mode is enabled by default. If the load current decreases, the converter will enter Power Save Mode operation automatically. During Power Save Mode the converter skips switching and operates with reduced frequency in PFM mode and with a minimum quiescent current to maintain high efficiency. The converter will position the output voltage typically +1% above the nominal output voltage. This voltage positioning feature minimizes voltage drops caused by a sudden load step.

The transition from PWM Mode to PFM Mode occurs once the inductor current in the Low Side MOSFET switch becomes 0.

During the Power Save Mode the output voltage is monitored with a PFM comparator. As the output voltage falls below the PFM comparator threshold of $V_{OUTnominal} + 1\%$, the device starts a PFM pulse. For this the High Side MOSFET switch will turn on and the inductor current ramps up. Then it will be turned off and the Low Side MOSFET switch will be turned on until the inductor current becomes 0.

The converter effectively delivers a current to the output capacitor and the load. If the load is below the delivered current the output voltage will rise. If the output voltage is equal or higher than the PFM comparator threshold, the device stops switching and enters a sleep mode with typical $15\mu A$ current consumption.

In case the output voltage is still below the PFM comparator threshold, further PFM current pulses will be generated until the PFM comparator threshold is reached. The converter starts switching again once the output voltage drops below the PFM comparator threshold.

With a single threshold comparator, the output voltage ripple during PFM Mode operation can be kept very small. The ripple voltage depends on the PFM comparator delay, the size of the output capacitor and the inductor value. Increasing output capacitor values and/or inductor values will minimize the output ripple.

The PFM Mode is left and PWM Mode entered in case the output current can not longer be supported in PFM Mode or if the output voltage falls below a second threshold, called PFM comparator low threshold. This PFM comparator low threshold is set to -1% below nominal V_{out} , and enables a fast transition from Power Save Mode to PWM Mode during a load step. In Power Save Mode the quiescent current is reduced typically to $15\mu A$.

The Power Save Mode can be disabled through the I2C interface for each of the step-down converters independent from each other. If Power Save Mode is disabled, the converter will then operate in fixed PWM mode.

Dynamic Voltage Positioning

This feature reduces the voltage under/overshoots at load steps from light to heavy load and vice versa. It is active in Power Save Mode. It provides more headroom for both the voltage drop at a load step, and the voltage increase at a load throw-off. This improves load transient behavior. At light loads, in which the converter operates in PFM Mode, the output voltage is regulated typically 1% higher than the nominal value. In case of a load transient from light load to heavy load, the output voltage drops until it reaches the PFM comparator low threshold set to -1% below the nominal value and enters PWM mode. During a load throw off from heavy load to light load, the voltage overshoot is also minimized due to active regulation turning on the Low Side MOSFET switch.

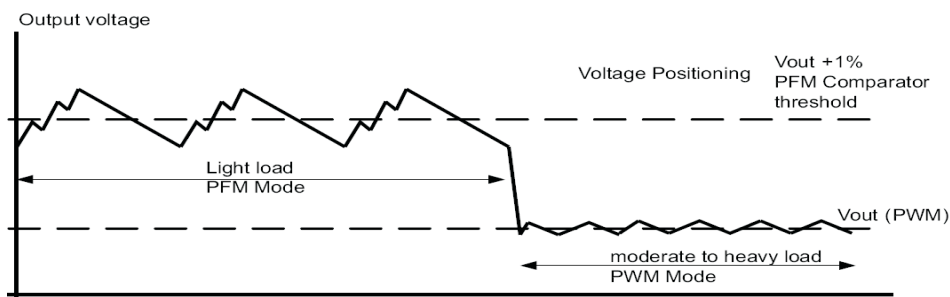

Figure 30. Power Save Mode

100% Duty Cycle Low Dropout Operation

The device starts to enter 100% duty cycle Mode once the input voltage comes close the nominal output voltage. In order to maintain the output voltage, the High Side MOSFET switch is turned on 100% for one or more cycles.

With further decreasing V_{IN} the High Side MOSFET switch is turned on completely. In this case the converter offers a low input-to-output voltage difference. This is particularly useful in battery-powered applications to achieve longest operation time by taking full advantage of the whole battery voltage range.

The minimum input voltage to maintain regulation depends on the load current and output voltage, and can be calculated as:

$$V_{in_{min}} = V_{out_{max}} + I_{out_{max}} \times (R_{DSon_{max}} + R_L) \quad (3) \quad (3)$$

With:

$I_{out_{max}}$ = maximum output current plus inductor ripple current

$R_{DSon_{max}}$ = maximum P-channel switch R_{DSon} .

R_L = DC resistance of the inductor

$V_{out_{max}}$ = nominal output voltage plus maximum output voltage tolerance

Under-Voltage Lockout

The under voltage lockout circuit prevents the device from malfunctioning at low input voltages and from excessive discharge of the battery and disables the DCDC converters and LDOs. The under-voltage lockout threshold is configurable in the range of typically 2.8V to 3.25V with falling voltage at the SYS pin. The default undervoltage lockout voltage as well as the hysteresis are defined in register CON_CTRL2. The default undervoltage lockout voltage is 3.0V with 500mV hysteresis.

SHORT-CIRCUIT PROTECTION

The High Side and Low Side MOSFET switches are short-circuit protected with maximum output current = ILIMF. Once the High Side MOSFET switch reaches its current limit, it is turned off and the Low Side MOSFET switch is turned. The High Side MOSFET switch can only turn on again, once the current in the Low Side MOSFET switch decreases below its current limit.

Soft Start

The 3 step-down converters in have an internal soft start circuit that controls the ramp up of the output voltage. The output voltage ramps up from 5% to 95% of its nominal value within typ. 250 μ s. This limits the inrush current in the converter during start up and prevents possible input voltage drops when a battery or high impedance power source is used. The Soft start circuit is enabled after the start up time t_{start} has expired.

During soft start, the output voltage ramp up is controlled as shown in [Figure 31](#).

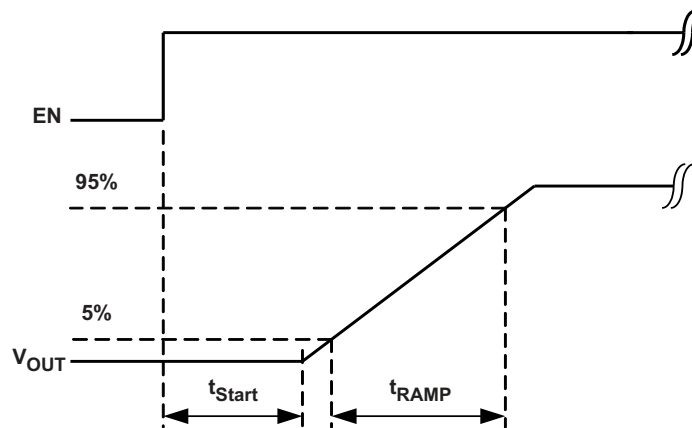

Figure 31. Soft Start

ENABLE

To start up each converter independently, the device has a separate enable pin for each of the DCDC converters. In order to enable any converter with its enable pins, the devices need to be in ON-state by pulling $PB_IN=LOW$ or $POWER_ON=HIGH$. The sequencing option programmed needs to be $DCDC_SQ[2..0] = 101$.

If EN_DCDC1 , EN_DCDC2 , EN_DCDC3 are set to high, the corresponding converter starts up with soft start as previously described.

Pulling the enable pin low forces the device into shutdown, with a shutdown quiescent current as defined in the electrical characteristics. In this mode, the high side and low side MOSFETs are turned-off, and the entire internal control circuitry is switched-off. If disabled, the outputs of the DCDC converters are pulled low by internal 250 Ω resistors, actively discharging the output capacitor. For proper operation the enable pins must be terminated and must not be left floating.

Optionally, there is internal sequencing for the DCDC converters and both LDOs available. Bits DCDC_SQ[0..2] in register CON_CTRL1 define the start-up and shut-down sequence for the DCDC converters. Depending on the sequencing option, the signal at EN_DCDC1, EN_DCDC2 and EN_DCDC3 are ignored. For automatic internal sequencing, the enable signals which are not used should be connected to GND.

LDO1 and LDO2 will start up automatically as defined in register LDO_CTRL1. See details about the sequencing options in the register description for CON_CTRL1 and LDO_CTRL1.

RESET

The contain circuitry that can generate a reset pulse for a processor with a certain delay time. The input voltage at a comparator is sensed at an input called THRESHOLD. When the voltage exceeds the threshold, the output goes high with the delay time defined in register PGOOD. The reset circuitry is not active in OFF-state. The pull-up resistor for this open drain output must not be connected directly to the battery as this may cause a leakage path when the power path (SYS voltage) is turned off. The reset delay time equals the setting for the PGOOD signal.

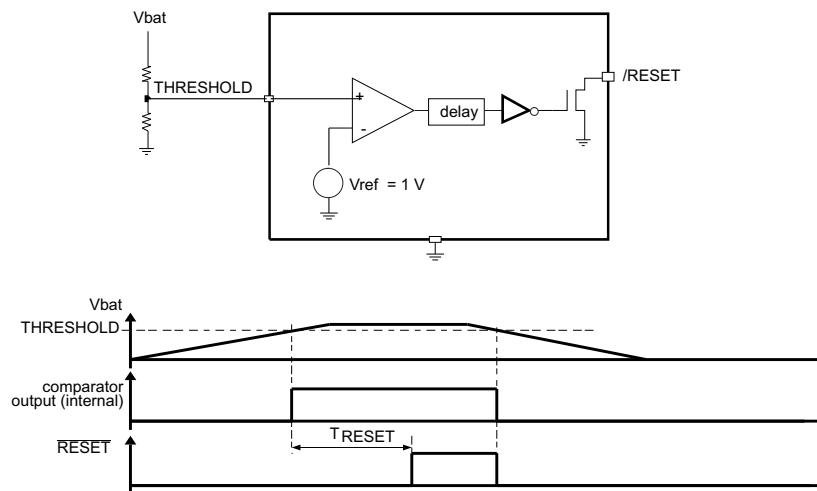

Figure 32. Reset Timing

PGOOD (reset signal for applications processor)

This open drain output generates a power-good signal depending on the status of the power good Bits for the DCDC converters and the LDOs. Register PGOODMASK defines which of the power good Bits of the converters and LDOs are used to drive the external PGOOD signal low when the voltage is below the target value. If e.g., Bit MASK DCDC2 is set to 1, the PGOOD pin will be driven low as long as the output of DCDC2 is below the target voltage. If the output voltage of DCDC2 rises to its nominal value, the PGOOD pin will be released after the delay time defined. See the default settings in the register description.

PB_IN (Push-button IN)

This pin is the ON/OFF button for the PMU to leave OFF-state and enter ON-state by pulling this pin to GND. Entering ON-state will first ramp the output voltage of the power path (SYS), load the default register settings and start up the DCDC converters and LDOs with the sequencing defined. In ON-state, the I2C interface is active and the wLED converter can be enabled. The system turns on if PB_IN is pulled LOW for >50ms (debounce time) AND the output voltage of the power path manager is above the undervoltage lockout voltage ($AVDD6 > 3V$). This is for $V_{bat} > 3V$ OR $V_{AC} > 3V$ OR $V_{USB} > 3V$. The default voltage for the undervoltage lockout voltage can be changed with Bits <UVLO1>, <UVLO0> in register CON_CTRL2. The value will be valid until the device was turned off completely by entering Off state. The system turns off if PB_IN is released OR the system voltage falls below the undervoltage lockout voltage of 3V. This is the case when either the battery voltage drops below 3.0V or the input voltage at the pins AC or USB is below 3V. In order to keep the enabled after PB_IN is released HIGH, there is an input pin called POWER_ON which needs to be pulled HIGH before the PB_IN button is released. POWER_ON=HIGH will typically be asserted by the application processor to keep the PMU in ON-state after the power button at PB_IN is released.

In addition to this, there is a 15s timer which will drive PGOOD=LOW for 0.5ms when 15s are expired. The 15s timer is enabled again when PB_IN is released HIGH. If PB_IN is pulled LOW for 30s continuously, PGOOD will be driven LOW only once after the first 15s. When PGOOD is driven LOW due to PB_IN=low for 15s, all registers in are set to their default value. See [Figure 33](#).

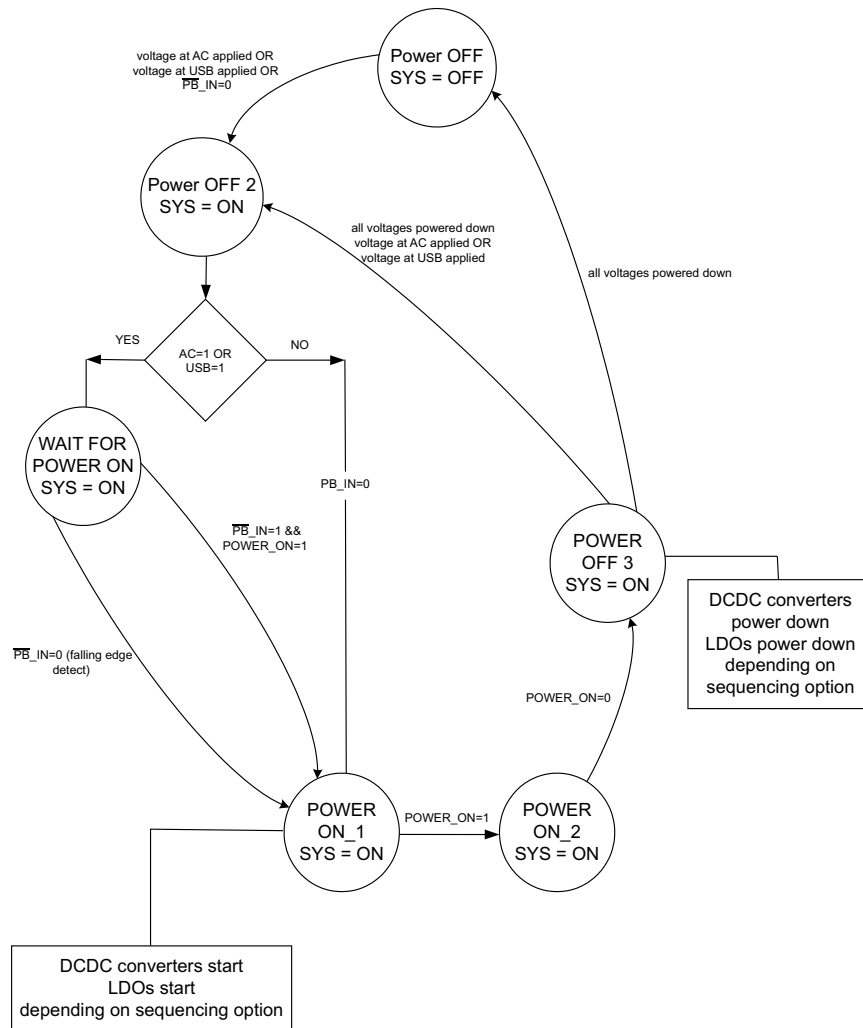

Figure 33. State Machine

PB_OUT

This pin is a status output. PB_OUT is used as the wake-up interrupt to an application processor based on the status of PB_IN. If PB_IN=LOW, PB_OUT = LOW (after 50ms debounce). If PB_IN=HIGH, PB_OUT= high impedance (HIGH).

The pull-up resistor for this open drain output must not be connected directly to the battery as this may cause a leakage path when the power path (SYS) is turned off.

POWER_ON

This pin is an input to the PMU which needs to be pulled HIGH for the PMU to stay in POWER ON_2-state once PB_IN is released. Once this pin is pulled LOW while PB_IN=LOW, the PMU is shutting down without delay, turning off the DCDC converters and the LDOs. If POWER_ON is pulled HIGH while there is power at USB or AC, the will enter POWER ON_2-state and start the DCDC converters and LDOs according to the sequence programmed. See [Figure 33](#).

SHORT-CIRCUIT PROTECTION

All outputs are short circuit protected with a maximum output current as defined in the electrical specifications.

THERMAL SHUTDOWN

As soon as the junction temperature, T_j , exceeds typically 150°C for the DCDC converters or LDOs, the device goes into thermal shutdown. In this mode, the high side MOSFETs are turned-off. The device continues its operation when the junction temperature falls below the thermal shutdown hysteresis again. A thermal shutdown for one of the DCDC converters or LDOs will disable all step-down converters simultaneously.

Low Dropout Voltage Regulators

The low dropout voltage regulators are designed to operate well with low value ceramic input and output capacitors. They operate with input voltages down to 1.8V. The LDOs offer a maximum dropout voltage of 200mV at rated output current. Each LDO supports a current limit feature. LDO2 is enabled internally using Bit ENABLE_LDO2 in register CON_CTRL1. The output voltage for LDO2 is defined by the settings in register DEFLDO2. LDO2 can also be configured in such a way that it follows the output voltage of converter DCDC3 by setting Bit LDO2 TRACKING = 1 in register DEFLDO2.

LDO1 is enabled internally using Bit ENABLE_LDO1 in register CON_CTRL1. The output voltage for LDO1 is defined by the settings in register DEFLDO1. LDO1 can also be enabled automatically depending on the settings in register LDO_CTRL1.

White LED Boost Converter

The converter is in shutdown mode by default and is being turned on by setting the enable Bit with the I2C interface or for TPS65072 with pin EN_wLED. The enable Bit is located in register WLED_CTRL1 and is called ENABLE_ISINK as it enables the current sink for the white LEDs. Once enabled, an output voltage is automatically generated at FB_wLED, high enough to force the programmed current through the string of white LEDs. Two strings of white LEDs can be powered. The current in each of the two strings is regulated by an internal current sink at pins Isink1 and Isink2. The maximum current through the current sinks is set with two external resistors connected from pins ISET1 and ISET2 to GND. ISET1 sets the maximum current when Bit CURRENT_LEVEL in register WLED_CTRL2 is set to 1. If this Bit is set to 0, which is the default setting, the maximum current is defined by the resistor connected at ISET2. This allows change between two different maximum current settings during operation. The LED current can further be dimmed with an internal PWM signal. The duty cycle for this PWM signal can be changed with the Bits LED DUTY CYCLE 0 to LED DUTY CYCLE 6 in register WLED_CTRL2 in a range from 1% to 100%. In case a dimming ratio higher than 1:100 is needed, the maximum LED current need to be changed to a lower value as defined with Iset2. In order to do this without any flicker, the PWM dimming and the current level is defined in the same register, so both settings can be changed at the same time with a single write access to register WLED_CTRL2. An internal overvoltage protection limits the maximum voltage at FB_wLED to 37V typically. The output voltage at FB_WLED also has a lower limit which is set to 12V. In case less than 4LEDs are used, the output voltage at the boost converter will not drop below 12V but the voltage from ISINK1 and ISINK2 to GND is increased accordingly.

A/D Converter

The 10Bit successive approximation (SAR) A/D converter with an input multiplexer can be used to monitor different voltages in the system. These signals are monitored:

- Battery voltage
- Voltage at AC input
- Voltage at SYS output
- Input voltage of battery charger
- Battery temperature
- Battery charge current (voltage at pin Iset; $I_{charge} = U_{ISET}/R_{set} \times K_{ISET}$)
- External voltage 1 to external voltage 4 (AD_IN1 to AD_IN4); 0V to 2.25V
- Optionally: External voltage 5 to external voltage 7 (AD_IN5 to AD_IN7); 0V to 6.0V
- Internal channel AD_IN14 and AD_IN15 for touch screen measurements

The A/D converter uses an internal 2.26V reference. The reference needs a bypass capacitor for stability which

is connected to pin BYPASS. The pin can be used as a reference output with a maximum output current of 0.1mA. The internal reference voltage is forced to be on when the ADC or the touch screen interface is enabled. The reference voltage can additionally forced to be on using Bit Vref_enable in register ADCONFIG while ADC and touch screen are off to allow external circuits to be supplied with a precise reference voltage while ADC and touch screen are not used.

Touch Screen Interface

The touch screen itself consists of two parallel plates, called the X and Y plates, separated by short distance; contact is initiated by using a stylus or your finger. This action creates a series of resistances noted by RX1, RX2, RY1, RY2, and Rcontact, shown in Figure 35. The points shown in the diagram as TSX1, TSX2, TSY1 and TSY2 are connected to the touch screen interface. The resistances RX1 and RX2 scale linearly with the x-position of the point of contact, where the RY1 and RY2 resistances scale with the y-position. The Rcontact resistance decreases as the pressure applied at the point of contact increases and increases as the pressure decreases. Using these relationships, the touch screen interface can make measurements of either position or pressure.

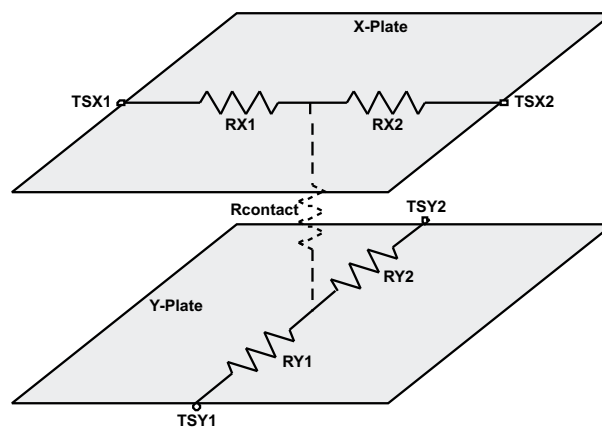

Figure 34. Touch Screen

The touch screen interface consists of a digital state machine, a voltage reference, and an analog switch matrix which is connected to the four wire resistive touch screen inputs (TSX1, TSX2, TSY1, TSY2) and an internal 10-Bit ADC. The state machine controls the sequencing of the switch matrix to cycle through the three types of measurement modes (position, pressure, plate resistance) and the low power standby mode. The separate internal voltage reference (TSREF) is disabled in standby and off modes. The voltage is generated by an internal LDO. Its voltage is bypassed by a capacitor connected to pin INT_LDO. The state of the touch screen is controlled by the TSC_M[2,0] Bits of the TSCMODE register (08h) as shown in Table 2. The touch screen controller uses transfer gates to the internal ADC on input channels AD_IN14 and AD_IN15.

Table 2. TSC Modes

CONTROL MULTIPLEXER			CONNECTIONS				MODE	MEASUREMENT
TSC_M2	TSC_M1	TSC_M0	TSX1	TSX2	TSY1	TSY2		
0	0	0	TSREF PMOS	GND NMOS	ADC_IN3 TGATE	ADC_IN4 TGATE	X-Position	Voltage TSY1
0	0	1	ADC_IN1 TGATE	ADC_IN2 TGATE	TSREF PMOS	GND NMOS	Y-Position	Voltage TSX1
0	1	0	TSREF	TSREF	GND NMOS	GND NMOS	Pressure	Current TSX1 and TSX2
0	1	1	TSREF PMOS	GND NMOS	HiZ	HiZ	Plate X Reading on ADC_IN14	Current TSX1
1	0	0	HiZ	HiZ	TSREF PMOS	GND NMOS	Plate Y Reading on ADC_IN14	Current TSY1
1	0	1	TSREF TGATE	TSREF TGATE	GND NMOS	GND NMOS	TSC standby	Voltage TSX1 and TSX2

Table 2. TSC Modes (continued)

CONTROL MULTIPLEXER			CONNECTIONS				MODE	MEASUREMENT
TSC_M2	TSC_M1	TSC_M0	TSX1	TSX2	TSY1	TSY2		
1	1	0	A/D TGATE	A/D TGATE	A/D TGATE	A/D TGATE	A/D	ADC used as stand alone ADC using its analog inputs
1	1	1	OPEN	OPEN	OPEN	OPEN	Disabled (no interrupt)	None

If the Touch screen multiplexer is set to disabled mode [111], touch to the screen will not be detected. Standby mode is entered by setting TSC_M[2:0] to 101. When there is a touch, the controller will detect a change in voltage at the TSX1 point and after a 8ms deglitch the $\overline{\text{INT}}$ pin will be asserted if the interrupt is unmasked in register INT. Once the host detects the interrupt signal, will enable the ADC converter and set the TSC_M<2:0> via the I²C bus to select any of five measurements (position, pressure, plate) as shown in [Table 3](#).

Table 3. TSC Equations

MEASUREMENT	CHANNEL	EQUATION
X Plate resistance	AD_IN14	$R_x = V_{TSREF} / [(V_{ADC} / 22k) \times 150]$
Y plate resistance	AD_IN14	$R_y = V_{TSREF} / [(V_{ADC} / 22k) \times 150]$
X position	AD_IN14	$X_{pos} = R_{x2} / (R_{x1} + R_{x2}) = R_{x2} / R_x$ $R_{x2} = V_{ADC} \times R_x / V_{TSREF}; R_{x1} = R_x - R_{x2}$ $X_{pos} = ADRESULT / 1024$
Y position	AD_IN14	$Y_{pos} = R_{y2} / (R_{y1} + R_{y2}) = R_{y2} / R_y$ $R_{y2} = V_{ADC} \times R_y / V_{TSREF}; R_{y1} = R_y - R_{y2}$ $Y_{pos} = ADRESULT / 1024$
Pressure	AD_IN14	$R_c = R - R_{x1} // R_{x2} - R_{y1} // R_{y2}$ $R = V_{TSREF} / [(V_{ADC} / 22k) \times 150]$ $R_{x1} // R_{x2} = R_x \times X_{pos} \times (1 - X_{pos})$ $R_{y1} // R_{y2} = R_y \times Y_{pos} \times (1 - Y_{pos})$

Performing Measurements Using the Touch Screen Controller

In order to take measurements with the touch screen controller, the ADC has to be enabled and configured for use with the touch screen controller (TSC) first. In case the TSC is planned to be operated interrupt driven, the TSC needs to be in *TSC standby* mode per default. Only in *TSC standby* mode an interrupt is generated based on a *touch* of the screen. The TSC should therefore be in this mode until a *touch* is detected. Afterwards, the TSC has to be configured for x-position measurement followed by y-position measurement. Now, the TSC can be set to *TSC standby* again to wait for the next *touch* of the screen. For a non-interrupt driven sequence, see TSCMODE. Register Address: 08h (page 50) in the *Registers* section. A typical interrupt driven sequence is given below:

- Set TSCMODE to 101 to set TSC to *TSC standby*, so an interrupt is generated when the screen is touched
- Set Bit AD enable = 1 to provide power to the ADC
- Set input select for the ADC in register ADCONFIG to 1110 (AD_IN14 selected)
- In register INT, set MASK TSC = 1 to unmask the interrupt on a *touch* of the touch screen
- Read Bit TSC INT as it will be set after the TSC has been configured. Reading clears the interrupt.
- After a *touch* was detected, an interrupt is generated by \overline{INT} pin going LOW
- Read Bit TSC INT to clear the interrupt
- Set TSCMODE to 000 to select *x-position measurement*
- Start an ADC conversion by setting CONVERSION START = 1; wait until END OF CONVERSION = 1
- Read register ADRESULT_1 and AD_RESULT_2
- Set TSCMODE to 001 to select *y-position measurement*
- Start an ADC conversion by setting CONVERSION START = 1; wait until END OF CONVERSION = 1
- Read register ADRESULT_1 and AD_RESULT_2
- Set TSCMODE to 101 to set TSC to *TSC standby* again

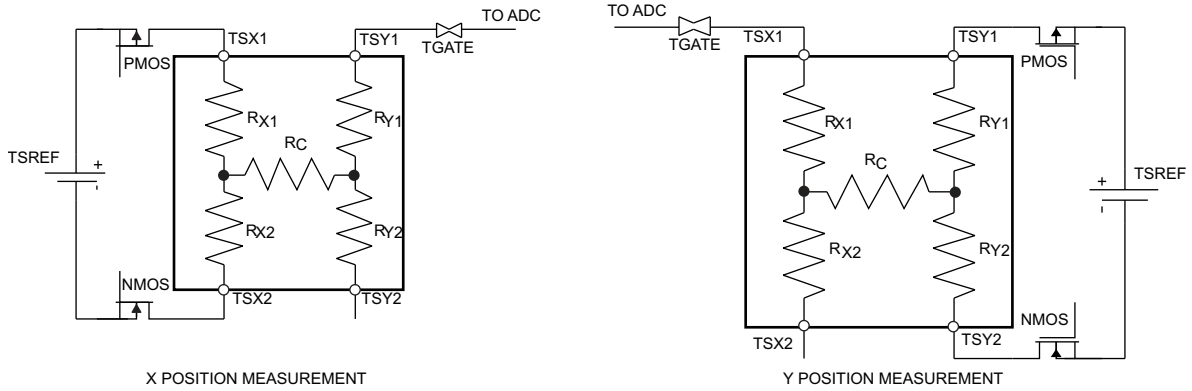

Figure 35. Two Position Measurement

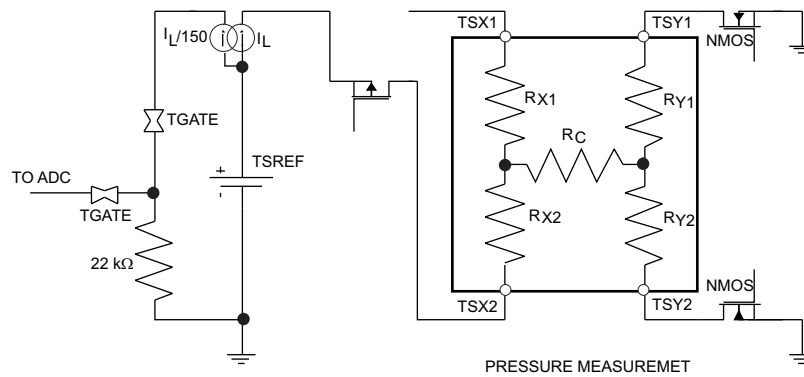

Figure 36. Pressure Measurement

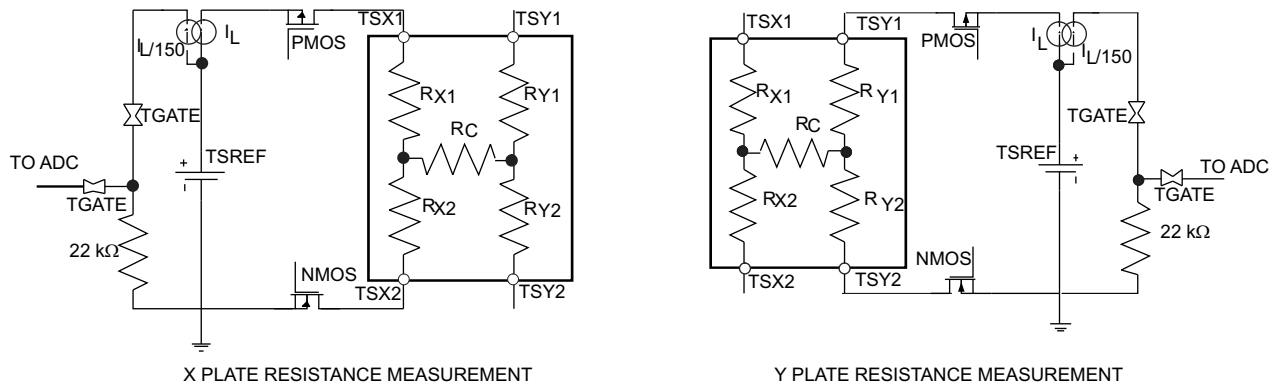

Figure 37. Two Plate Resistance Measurement

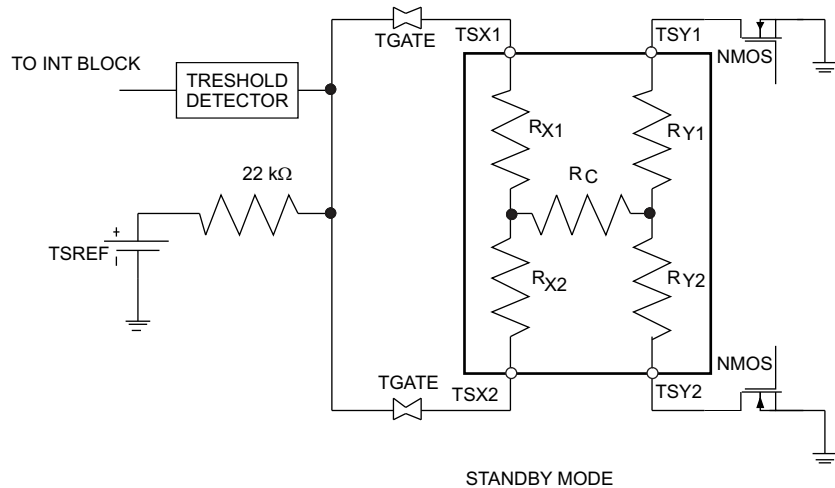

Figure 38. Touch Screen Standby Mode

I2C Interface Specification:

Serial interface

The serial interface is compatible with the standard and fast mode I²C specifications, allowing transfers at up to 400kHz. The interface adds flexibility to the power supply solution, enabling most functions to be programmed to new values depending on the instantaneous application requirements and charger status to be monitored. The has a 7-Bit address: '1001000', other addresses are available upon contact with the factory. Attempting to read data from register addresses not listed in this section will result in 00h being read out. For normal data transfer, SDAT is allowed to change only when SCLK is low. Changes when SCLK is high are reserved for indicating the start and stop conditions. During data transfer, the data line must remain stable whenever the clock line is high. There is one clock pulse per Bit of data. Each data transfer is initiated with a start condition and terminated with a stop condition. When addressed, the device generates an acknowledge Bit after the reception of each byte. The master device (microprocessor) must generate an extra clock pulse that is associated with the acknowledge Bit. The device must pull down the SDAT line during the acknowledge clock pulse so that the SDAT line is a stable low during the high period of the acknowledge clock pulse. The SDAT line is a stable low during the high period of the acknowledge-related clock pulse. Setup and hold times must be taken into account. During read operations, a master must signal the end of data to the slave by not generating an acknowledge Bit on the last byte that was clocked out of the slave. In this case, the slave device must leave the data line high to enable the master to generate the stop condition.

All registers are set to their default value by one of these conditions:

- Voltage is below the UVLO threshold defined with registers <UVLO1>, <UVLO0>
- PB_IN is asserted LOW for >15s (option)

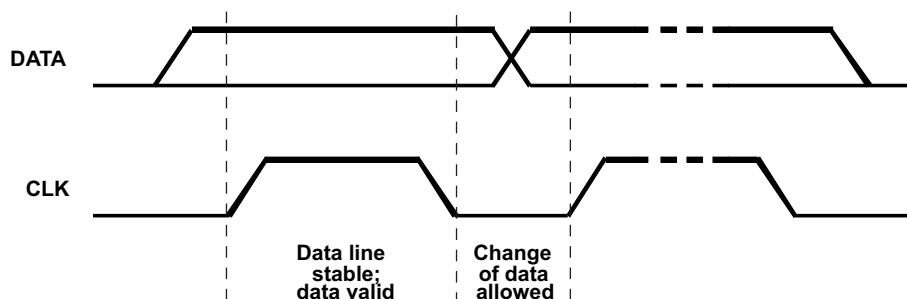

Figure 39. Bit Transfer on the Serial Interface

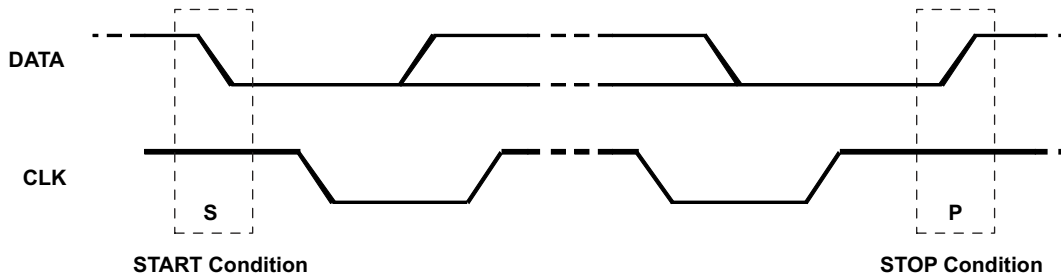
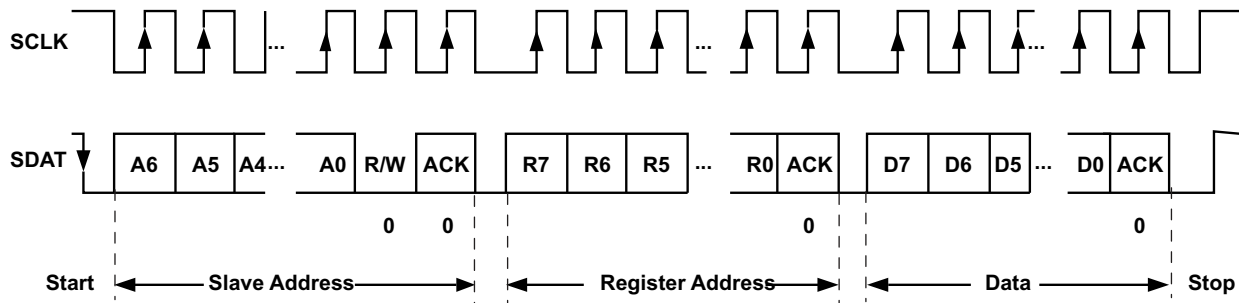
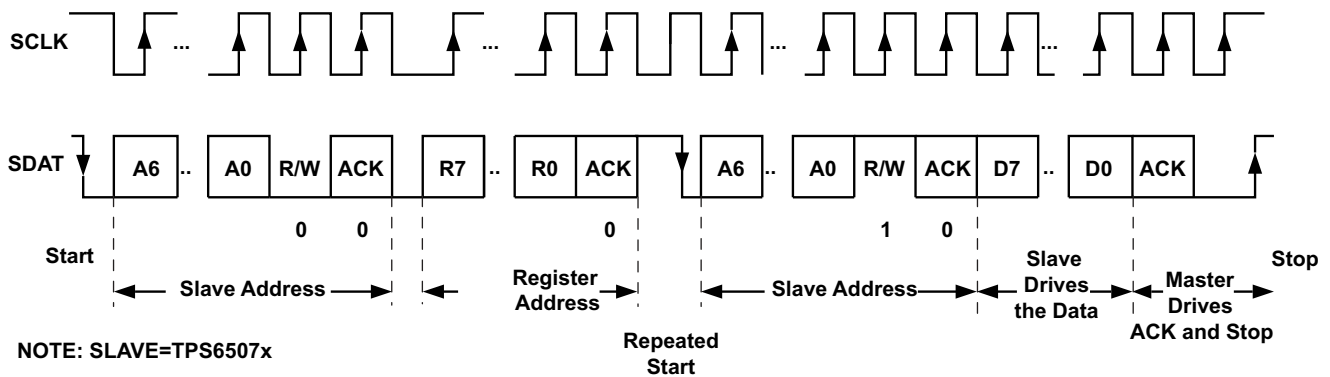

Figure 40. START and STOP Conditions



NOTE: SLAVE=TPS6507x

Figure 41. Serial I/f WRITE to TPS6507x



NOTE: SLAVE=TPS6507x

Figure 42. Serial I/f READ from TPS6507x: Protocol A

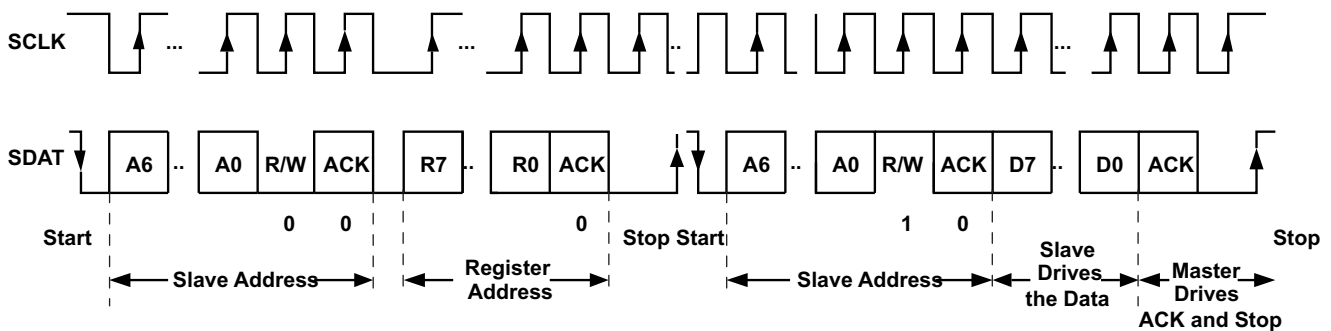
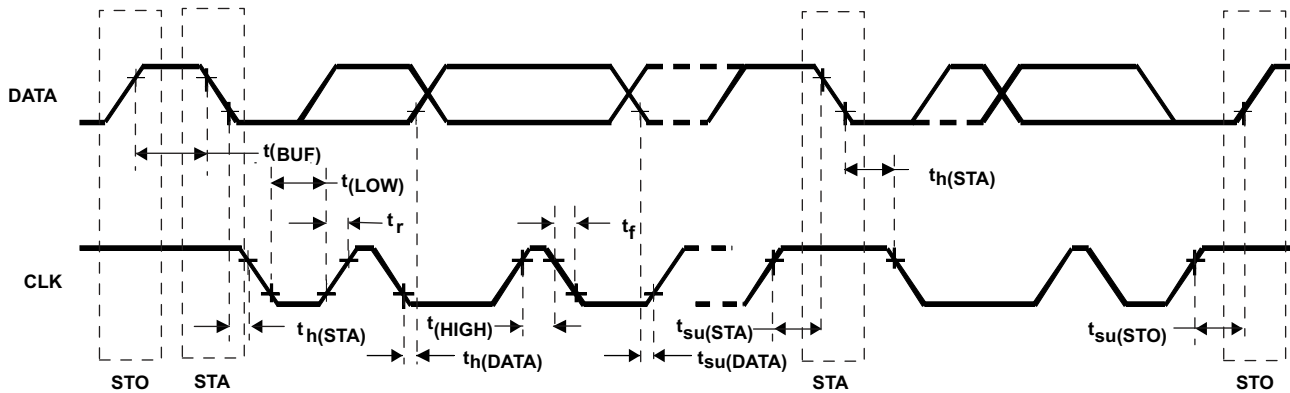

Figure 43. Serial I/f READ from TPS6507x: Protocol B

Figure 44. Serial I/f Timing Diagram

		MIN	MAX	UNIT
f_{MAX}	Clock frequency		400	kHz
$t_{WH(HIGH)}$	Clock high time	600		ns
$t_{WL(LOW)}$	Clock low time	1300		ns
t_R	SDAT and CLK rise time		300	ns
t_F	SDAT and CLK fall time		300	ns
$t_{h(STA)}$	Hold time (repeated) START condition (after this period the first clock pulse is generated)	600		ns
$t_{h(SDAT)}$	Setup time for repeated START condition	600		ns
$t_{h(SDAT)}$	Data input hold time	0		ns
$t_{su(SDAT)}$	Data input setup time	100		ns
$t_{su(STO)}$	STOP condition setup time	600		ns
$t_{(BUF)}$	Bus free time	1300		ns

REGISTERS
PPATH1. Register Address: 01h

PPATH1	B7	B6	B5	B4	B3	B2	B1	B0
Bit name and function	USB power	AC power	$\overline{\text{USB}}$ power enable	$\overline{\text{AC}}$ power enable	AC input current MSB	AC input current LSB	USB input current MSB	USB input current LSB
Default	x	x	0	0	1	1	0	1
Set by signal								
Default value loaded by:			UVLO	UVLO	Voltage removed at AC OR UVLO	Voltage removed at AC OR UVLO	Voltage removed at USB OR UVLO	Voltage removed at USB OR UVLO
Read/write	R	R	R/W	R/W	R/W	R/W	R/W	R/W

- Bit 7 USB power:
 0 = USB power is not present and/or not in the range valid for charging
 1 = USB source is present and in the range valid for charging. B7 remains active as long as the charge source is present
- Bit 6 AC power:
 0 = wall plug is not present and/or not in the range valid for charging
 1 = wall plug source is present and in the range valid for charging. B6 remains active as long as the charge source is present
- Bit 5 $\overline{\text{USB}}$ POWER ENABLE
 0 = USB power input is enabled
 1 = USB power input is disabled (USB suspend mode)
- Bit 4 $\overline{\text{AC}}$ POWER ENABLE
 0 = AC power input is enabled
 1 = AC power input is disabled
- Bit 3..2 AC INPUT CURRENT
 00 = input current from AC input is 100 mA max
 01 = input current from AC input is 500 mA max
 10 = input current from AC input is 1300 mA max
 11 = input current from AC input is 2500 mA
- Bit 1..0 USB INPUT CURRENT
 00 = input current from USB input is 100 mA max
 01 = input current from USB input is 500 mA max
 10 = input current from USB input is 800 mA max
 11 = input current from USB input is 1300 mA max

Note: safety timers are cleared if the input voltage at both AC and USB are removed.

INT. Register Address: 02h

INT	B7	B6	B5	B4	B3	B2	B1	B0
Bit name and function	MASK AC/USB	MASK TSC	MASK $\overline{\text{PB_IN}}$		TSC INT	$\overline{\text{PB_IN}}$ INT	USB or AC input voltage applied	USB or AC input voltage removed
Default	0	0	0	0	0	0	0	0
Set by signal					Cleared when read	Cleared when read	Cleared when read	Cleared when read
Default value loaded by:	UVLO	UVLO	UVLO		UVLO	UVLO	UVLO	UVLO
Read/write	R/W	R/W	R/W	R	R	R	R	R

Bit 7 MASK AC/USB

0 = no interrupt generated if voltage at AC or USB is applied or removed

 1 = the pin $\overline{\text{INT}}$ is actively pulled low if one of the Bits 1 to Bit 0 are 1

Bit 6 MASK TSC

0 = no interrupt generated if the touch screen is detecting a “touch”

 1 = the pin $\overline{\text{INT}}$ is actively pulled low if a “touch” on the touch screen is detected

Bit 5 MASK $\overline{\text{PB_IN}}$

 0 = no interrupt generated if the $\overline{\text{PB_IN}}$ is pulled low.

 1 = the pin $\overline{\text{INT}}$ is actively pulled low if $\overline{\text{PB_IN}}$ was pulled low.

Bit 3 TSC INT

0 = no “touch” on the touch screen detected

1 = “touch” detected and the Bit has not been read ever since

Bit 2 $\overline{\text{PB_IN}}$ INT

 0 = $\overline{\text{PB_IN}}$ not active

 1 = $\overline{\text{PB_IN}}$ is actively pulled low (or high optionally) and the Bit has not been read ever since

Bit 1 USB or AC INPUT VOLTAGE APPLIED

0 = no change (voltage still applied or never applied)

1 = voltage at USB or AC has been applied and the Bit has not been read ever since

Bit 0 USB or AC INPUT VOLTAGE REMOVED

0 = no change (voltage still applied or never applied)

1 = the voltage at USB or AC has been removed and the Bit has not been read ever since

CHGCONFIG0. Register Address: 03h

CHGCONFIG0	B7	B6	B5	B4	B3	B2	B1	B0
Bit name and function	Thermal regulation	DPPM active	Thermal Suspend	Term Current		Chg Timeout	Prechg Timeout	BatTemp error
Default	x	x	x	x	0	x	x	x
Set by signal								
Default value loaded by:	UVLO	UVLO	UVLO	UVLO		UVLO	UVLO	UVLO
Read/write	R	R	R	R	R	R	R	R

- Bit 7 THERMAL REGULATION:
 0 = charger is in normal operation
 1 = charge current is reduced due to high chip temperature
- Bit 6 DPPM ACTIVE:
 0 = DPPM loop is not active
 1 = DPPM loop is active; charge current is reduced to support the load with the current required
- Bit 5 THERMAL SUSPEND:
 0 = charging is allowed
 1 = charging is momentarily suspended because battery temperature is out of range
- Bit 4 TERM CURRENT:
 0 = charge termination current threshold has not been crossed; charging or no voltage at AC and USB
 1 = charge termination current threshold has been crossed and charging has been stopped. This can be due to a battery reaching full capacity or to a battery removal condition
- Bit 2..Bit1 CHG TIMEOUT, PRECHG TIMEOUT
 0 = charging, timers did not time out
 1 = one of the timers has timed out and charging has been terminated
- Bit 0 BAT TEMP ERROR:
 0 = battery temperature is in the allowed range for charging
 1 = no temperature sensor detected

CHGCONFIG1. Register Address: 04h

CHGCONFIG1	B7	B6	B5	B4	B3	B2	B1	B0
Bit name and function	Charge safety timer value1	Charge safety timer value0	Safety timer enable	SENSOR TYPE	Charger reset	Charge Termination ON/OFF	Suspend Charge	Charger enable
Default	0	0	1	1	0	0	0	1
Set by signal								
Default value loaded by:	UVLO	UVLO	UVLO	UVLO	UVLO	UVLO	UVLO	UVLO
Read/write	R/W	R/W	R/W	R/W	R/W	R/W	R/W	R/W

Bit 7..6 CHARGE SAFETY TIMER VALUE0/1:

- 00 = safety timer times out after 4 hours
- 01 = safety timer times out after 5 hours
- 10 = safety timer times out after 6 hours
- 11 = safety timer times out after 8 hours

Bit 5 SAFETY TIMER ENABLE

- 0 = pre-charge timer, fast charge timer and taper timers are disabled
- 1 = pre-charge timer, fast charge timer and taper timers are enabled

Bit 4 SENSOR TYPE (NTC for battery temperature measurement)

- 0 = 100k curve 1 NTC
- 1 = 10k curve 2 NTC

Bit 3 CHARGER RESET:

- 0 = inactive
- 1 = Reset active. This Bit must be set and then reset via the serial interface to restart the charge algorithm

Bit 2 CHARGE TERMINATION ON/OFF:

- 0 = charge termination enabled, based on timers and termination current
- 1 = charge termination will not occur and the charger will always be on

Bit 1 SUSPEND CHARGE:

- 0 = Safety Timer and Pre-Charge timers are not suspended
- 1 = Safety Timer and Pre-Charge timers are suspended

Bit 0 CHARGER ENABLE

- 0 = charger is disabled
- 1 = charger is enabled; toggling the enable Bit will not reset the charger. Use CHARGER RESET Bit to reset charger.

CHGCONFIG2. Register Address: 05h

CHGCONFIG2	B7	B6	B5	B4	B3	B2	B1	BO
Bit name and function	Dynamic Timer function	Precharge voltage	Charge voltage selection1	Charge voltage selection0				
Default	1	1	1	0	0	0	0	0
Set by signal								
Default value loaded by:	UVLO	UVLO	UVLO	UVLO				
Read/write	R/W	R/W	R/W	R/W	R	R	R	R

Bit 7 DYNAMIC TIMER FUNCTION

0 = safety timers run with their nominal clock speed

1 = clock speed is divided by 2 if thermal loop or DPPM loop is active

Bit 6 PRECHARGE VOLTAGE

0 = pre-charge to fast charge transition voltage is 2.5V

1 = pre-charge to fast charge transition voltage is 2.9V

Bit 5..4 CHARGE VOLTAGE SELECTION0/1:

00 = 4.10V

01 = 4.15V

10 = 4.20V

11 = 4.25V

CHGCONFIG3. Register Address: 06h

CHGCONFIG3	B7	B6	B5	B4	B3	B2	B1	B0
Bit name and function	Disable Isink at AC	Power path DPPM threshold1	Power path DPPM threshold0	Precharge time	Termination current factor1	Termination current factor0	Charger active	Disable Isink at USB
Default	0	1	1	0	0	1	x	0
Set by signal								
Default value loaded by:	UVLO	UVLO	UVLO	UVLO	UVLO	UVLO	UVLO	UVLO
Read/write	R/W	R/W	R/W	R/W	R/W	R/W	R	R/W

Bit 7 DISABLE ISINK AT AC (disables an internal current sink from pin AC to GND)

0 = 60 μ A current sink enabled when no input voltage at pin AC detected

1 = 60 μ A current sink disabled

Bit 6..5 POWER PATH DPPM THRESHOLD1/0:

00 = 3.5 V

01 = 3.75 V

10 = 4.25 V

11 = 4.50 V

Bit 4 PRECHARGE TIME

0 = pre-charge time is 30 min

1 = pre-charge time is 60 min

Bit 3..2 TERMINATION CURRENT FACTOR1/0:

00 = 0.04

01 = 0.1

10 = 0.15

11 = 0.2

Bit 1 CHARGER ACTIVE:

0 = charger is not charging

1 = charger is charging (DPPM or thermal regulation may be active)

Bit 0 DISABLE ISINK AT USB (disables an internal current sink from pin USB to GND)

0 = 60 μ A current sink enabled when no input voltage at pin USB detected

1 = 60 μ A current sink disabled

Note: There is a current sink on pins AC and USB which is activated when there is no voltage detected at the pin and Bit7 or Bit0 in CHCONFIG3 are set to 0. This is implemented in order to avoid the pins to be floating when not connected to a power source. The current sink is disabled automatically as soon as an input voltage is detected at the pin.

ADCONFIG. Register Address: 07h

ADCONFIG	B7	B6	B5	B4	B3	B2	B1	B0
Bit name and function	AD enable	Conversion start	End of conversion	Vref enable	INPUT SELECT_3	INPUT SELECT_2	INPUT SELECT_1	INPUT SELECT_0
Default	0	0	1	0	0	0	0	0
Set by signal								
Default value loaded by:	UVLO	UVLO	UVLO	UVLO	UVLO	UVLO	UVLO	UVLO
Read/write	R/W	R/W	R	R/W	R/W	R/W	R/W	R/W

Bit 7 AD ENABLE:

- 0 = A/D converter disabled
- 1 = A/D converter enabled

Bit 6 CONVERSION START

- 0 = no conversion in progress
- 1 = start A/D conversion, Bit is automatically cleared if conversion is done

Bit 5 END OF CONVERSION

- 0 = conversion did not finish
- 1 = conversion done

Bit 4 VREF ENABLE

- 0 = reference voltage LDO (pin BYPASS) for ADC is disabled
- 1 = reference voltage LDO (pin BYPASS) for ADC is enabled

Bit 3..0 INPUT SELECT – see table

INPUT SELECT_3	INPUT SELECT_2	INPUT SELECT_1	INPUT SELECT_0	FULL SCALE INPUT VOLTAGE	INPUT SELECTED
0	0	0	0	2.25V	Voltage at AD_IN1
0	0	0	1	2.25V	Voltage at AD_IN2
0	0	1	0	2.25V	Voltage at AD_IN3
0	0	1	1	2.25V	Voltage at AD_IN4
0	1	0	0	2.25V	Voltage at TS pin
0	1	0	1	2.25V	Voltage at ISET pin == battery charge current
0	1	1	0	6.0V	Voltage at AC pin
0	1	1	1	6.0V	Voltage at SYS pin
1	0	0	0	6.0V	Input voltage of the charger
1	0	0	1	6.0V	Voltage at BAT pins
1	0	1	0	6.0V	Voltage at AD_IN5 (at pin THRESHOLD)
1	0	1	1	6.0V	Voltage at AD_IN6 (at pin ISET1)
1	1	0	0	6.0V	Voltage at AD_IN7 (at pin ISET2)
1	1	1	0	2.25	Touch screen controller (TSC); all functions
1	1	1	1	2.25	Touch screen controller (TSC); x-position and y-position only

TSCMODE. Register Address: 08h

TSCMODE	B7	B6	B5	B4	B3	B2	B1	B0
Bit name and function						TSC_M2	TSC_M1	TSC_M0
Default	0	0	0	0	0	1	1	1
Set by signal								
Default value loaded by:						UVLO	UVLO	UVLO
Read/write	R	R	R	R	R	R/W	R/W	R/W

Bit 3..0 MODE SELECT BITS FOR THE TOUCH SCREEN INTERFACE

Note: Data conversions using the touch screen interface require setting the touch screen mode with register TSCMODE and selecting the analog input channel for the ADC according to the following table.

Measurement of x-position:

- Set TSCMODE to 000 to select x-position measurement
- Set Bit AD_ENABLE=1 to provide power to the ADC.
- Set input select for the ADC in register ADCONFIG to 1110 (AD_IN14 selected).
- Start a conversion by setting CONVERSION_START=1; wait until END_OF_CONVERSION=1
- Read register ADRESULT_1 and ADRESULT_2

TSC_M2	TSC_M1	TSC_M0	TSX1 (AD_IN1)	TSX2 (AD_IN2)	TSY1(AD_ IN3)	TSY2(AD_ IN4)	MODE	MEASUREMENT
0	0	0	TSREF	GND	A/D	HiZ	X-Position	Voltage TSY1
0	0	1	A/D	HiZ	TSREF	GND	Y-Position	Voltage TSX1
0	1	0	TSREF	TSREF	GND	GND	Pressure	Current TSX1 and TSX2
0	1	1	TSREF	GND	HiZ	HiZ	Plate X	Current TSX1
1	0	0	HiZ	HiZ	TSREF	GND	Plate Y	Current TSY1
1	0	1	V2	V2	GND	GND	TSC standby	Voltage TSX1 and TSX2
1	1	0	A/D	A/D	A/D	A/D	A/D	Voltage measurement with ADC
1	1	1	open	open	open	open	TSC and ADC disabled (no interrupt generation)	

ADRESULT_1. Register Address: 09h

ADRESULT_1	B7	B6	B5	B4	B3	B2	B1	B0
Bit name and function	AD_BIT7	AD_BIT6	AD_BIT5	AD_BIT4	AD_BIT3	AD_BIT2	AD_BIT1	AD_BIT0 LSB
Default	x	x	x	x	x	x	x	x
Set by signal								
Default value loaded by:	R	R	R	R	R	R	R	R
Read/write								

ADRESULT_2. Register Address: 0Ah

ADRESULT_2	B7	B6	B5	B4	B3	B2	B1	BO
Bit name and function							AD_BIT9 MSB	AD_BIT8
Default	0	0	0	0	0	0	x	x
Set by signal								
Default value loaded by:	R	R	R	R	R	R	R	R
Read/write								

PGOOD. Register Address: 0Bh

PGOOD	B7	B6	B5	B4	B3	B2	B1	BO
Bit name and function	$\overline{\text{Reset}}$	PGOOD DELAY 1	PGOOD DELAY 0	PGOOD VDCDC1	PGOOD VDCDC2	PGOOD VDCDC3	PGOOD LDO1	PGOOD LDO2
Default for -70, -73, -731, -732	x	1	1					
Default for TPS65072	x	0	0					
Set by signal				PGOOD VDCDC1	PGOOD VDCDC2	PGOOD VDCDC3	PGOOD LDO1	PGOOD LDO2
Default value loaded by:				PGOOD VDCDC1	PGOOD VDCDC2	PGOOD VDCDC3	PGOOD LDO1	PGOOD LDO2
Read/write	R	R/W	R/W	R	R	R	R	R

Bit 7 $\overline{\text{Reset}}$:

- 0 = indicates that the comparator input voltage is above the 1V threshold.
- 1 = indicates that the comparator input voltage is below the 1V threshold.

Bit 6..5 PGOOD DELAY 0,1 (sets the delay time of $\overline{\text{Reset}}$ and PGOOD output):

- 00 = delay is 20ms
- 01 = delay is 100ms
- 10 = delay is 200ms
- 11 = delay is 400ms

Bit 4 PGOOD VDCDC1:

- 0 = indicates that the VDCDC1 converter output voltage is below its target regulation voltage or disabled.
- 1 = indicates that the VDCDC1 converter output voltage is within its nominal range.

Bit 3 PGOOD VDCDC2:

- 0 = indicates that the VDCDC2 converter output voltage is below its target regulation voltage or disabled.
- 1 = indicates that the VDCDC2 converter output voltage is within its nominal range.

Bit 2 PGOOD VDCDC3:

- 0 = indicates that the VDCDC3 converter output voltage is below its target regulation voltage or disabled
- 1 = indicates that the VDCDC3 converter output voltage is within its nominal range.

Bit 1 PGOOD LDO1:

- 0 = indicates that LDO1 output voltage is below its target regulation voltage or disabled
- 1 = indicates that the LDO1 output voltage is within its nominal range.

Bit 0 PGOOD LDO2:

- 0 = indicates that the LDO2 output voltage is below its target regulation voltage or disabled.
- 1 = indicates that the LDO2 output voltage is within its nominal range.

PGOODMASK. Register Address: 0Ch

	B7	B6	B5	B4	B3	B2	B1	B0
Bit name and function			MASK VDCDC3 and LDO1	MASK VDCDC1	MASK VDCDC2	MASK VDCDC3	MASKLDO1	MASK LDO2
Default for -70	0	0	0	0	1	0	0	0
Default for -72	0	0	0	1	0	0	0	0
Default for -73, -731, -732	0	0	0	1	1	1	0	0
Set by signal								
Default value loaded by:			UVLO	UVLO	UVLO	UVLO	UVLO	UVLO
Read/write	R	R	R/W	R/W	R/W	R/W	R/W	R/W

Bit 5 MASK VDCDC3 and LDO1:

0 = indicates that the output voltage of either DCDC3 or LDO1 is within its nominal range. The PGOOD output is not affected (not driven LOW)

1 = indicates that both LDO1 AND DCDC3 output voltage is below its target regulation voltage or disabled. This will drive the PGOOD output low.

Bit 4..0 MASK VDCDC1/2/3, LDO1,2:

0 = the status of the power good Bit in Register $\overline{\text{PGOOD}}$ does not affect the status of the PGOOD output pin

1 = the PGOOD pin is driven low in case the output voltage of the converter or LDO is below its target regulation voltage or disabled.

CON_CTRL1. Register Address: 0Dh

CON_CTRL1	B7	B6	B5	B4	B3	B2	B1	B0
Bit name and function	DCDC_SQ2	DCDC_SQ1	DCDC_SQ0	DCDC1 ENABLE	DCDC2 ENABLE	DCDC3 ENABLE	LDO1 ENABLE	LDO2 ENABLE
Default for -70, -72, -73, -732 for TPS65731 only	See Table 9	See Table 9	See Table 9	1 1	1 1	1 1	1 1	1 0
Set by signal				DCDC1_E NZ	DCDC2_EN Z	DCDC3_EN Z	LDO_ENZ	LDO_ENZ
Default value loaded by:	UVLO	UVLO	UVLO	UVLO	UVLO	UVLO	UVLO	UVLO
Read/write	R/W	R/W	R/W	R/W	R/W	R/W	R/W	R/W

The CON_CTRL1 register can be used to disable and enable all power supplies via the serial interface. Default is to allow all supplies to be on, providing the relevant enable pin is high. The following tables indicate how the enable pins and the CON_CTRL1 register are combined. The CON_CTRL1 Bits are automatically reset to default when the corresponding enable pin is low.

Bit 7..5 DCDC_SQ2 to DCDC_SQ0: power-up sequencing (power down sequencing is the reverse)

000 = power-up sequencing is: DCDC2 only; DCDC1 and DCDC3 are not part of the automatic sequencing and are enabled by their enable pins EN_DCDC1 and EN_DCDC3

001 = power-up sequencing is DCDC2 and DCDC3 at the same time, DCDC1 is not part of the automatic sequencing and is enabled by its enable pin EN_DCDC1

010 = power-up sequencing is: DCDC1 when power good then DCDC2 and DCDC3 at the same time

011 = power-up sequencing is: DCDC3 when power good then DCDC2; DCDC1 is not part of the automatic sequencing and is controlled by its EN_DCDC1 pin.

100 = power-up sequencing is: DCDC3 is started at the same time with LDO2 if Bit MASK_EN_DCDC3 in register 0Eh is set (default is set). DCDC1 and DCDC2 are started at the same time when LDO2 is PGOOD (defined in LDO sequencing 111); DCDC3 is enabled or disabled with its EN_DCDC3 pin if MASK_EN_DCDC3 in register 0Eh is cleared (set =0). (Sirf PRIMA, start-up from OFF or start-up after SLEEP)

101 = DCDC converters are enabled individually with the external enable pins

110 = DCDC1 first, when power good then DCDC2, when power good then DCDC3

111 = power-up sequencing is: DCDC1 and DCDC2 at the same time >1ms after LDO2 has been started (defined in LDO sequencing 010); DCDC3 is not part of the automatic sequencing but is enabled with its EN_DCDC3 pin (Atlas4)

In case of automatic sequencing other than 101, the start is initiated by going into ON-state. DCDC converters that are not part of the automatic sequencing can be enabled by pulling their enable pin to a logic HIGH level at any time in ON-state. The enable pins for the converters that are automatically enabled, should be tied to GND. For sequencing option DCDC_SEQ=111, the start is initiated by going into ON-state, however, the external LDO connected to pin EN_EXTLDO is powered first, followed by LDO2.

(The sequencing of LDO1 and LDO2 is defined in register LDO_CTRL1)

TPS65070-Q1, TPS65072-Q1, TPS65073-Q1, TPS650732-Q1

SLVSAP7 – JANUARY 2011

www.ti.com

Bit 4..0 DCDC1,2,3: See tables below

EN_DCDC1 PIN	CON_CTRL1<4>	DCDC1 CONVERTER		EN_DCDC2 PIN	CON_CTRL1<3>	DCDC2 CONVERTER
0	x	disabled		0	x	disabled
1	0	disabled		1	0	disabled
1	1	enabled		1	1	enabled

EN_DCDC3 PIN	CON_CTRL1<2>	DCDC3 CONVERTER
0	x	disabled
1	0	disabled
1	1	enabled

CON_CTRL2. Register Address: 0Eh

CON_CTRL2	B7	B6	B5	B4	B3	B2	B1	B0
Bit name and function	ENABLE 1s timer	ENABLE 5s timer	DS_RDY	PWR_DS	MASK_EN_DCDC3	UVLO hysteresis	UVLO1	UVLO0
Default value loaded by:	UVLO	UVLO	UVLO	UVLO	UVLO	BG_GOOD	BG_GOOD	BG_GOOD
Read/write	R/W	R/W	R/W	R/W	R/W	R/W	R/W	R/W

Bit 7...6 ENABLE TIMERS:

0 = the state machine timers of 1s and 5s, respectively are disabled
 1 = the state machine timers of 1s and 5s, respectively are enabled

Bit 5 DS_RDY (data ready, memory content valid) for use with Sirf Prima processor DEEP SLEEP mode:

0 = status Bit which is indicating the memory content is not valid after wake up from DEEP SLEEP. This Bit is set / cleared by the Prima application processor. Cleared when device is in UVLO to tell processor there was a power loss. The Bits needs to be cleared by user software after a wake up from DEEP SLEEP to enable the DCDC2 converter to be powered down in shutdown sequencing depending on the status of LDO2.

1 = memory content is valid after wake up from DEEP SLEEP (set by I2C command by application processor only). The Prima processor is ready to power down to DEEP SLEEP mode or was just waking up from DEEP SLEEP mode.

Bit 4 PWR_DS (enter DEEP SLEEP for sequencing option DCDC_SEQ=100, LDO_SEQ=111):

0 = PMU is in normal operation

1 = PMU powers down all rails except DCDC2 and the external LDO on pin "EXT_LDO". PGOOD is pulled LOW.

Bit 3 MASK_EN_DCDC3; used for Prima application processor start-up sequencing:

0 = DCDC3 is enabled or disabled by the status of EN_DCDC3 for sequencing option DCDC_SEQ=100.

1 = DCDC3 will start at the same time with LDO2 for sequencing option DCDC_SEQ=100. The status of EN_DCDC3 is ignored

Bit 2 UNDERVOLTAGE LOCKOUT HYSTERESIS:

0 = 400mV hysteresis

1 = 500mV hysteresis

Bit 1..0 UVLO1, UVLO2 (undervoltage lockout voltage):

00 = the device turns off at 2.8V with the reverse of the sequencing defined in CON_CTRL1

01 = the device turns off at 3.0V with the reverse of the sequencing defined in CON_CTRL1

10 = the device turns off at 3.1V with the reverse of the sequencing defined in CON_CTRL1

11 = the device turns off at 3.25V with the reverse of the sequencing defined in CON_CTRL1

Note: The undervoltage lockout voltage is sensed at the SYS pin and the device goes to OFF state when the voltage is below the value defined in the register. BG_GOOD is the internal bandgap good signal which occurs at lower voltages than UVLO.

CON_CTRL3. Register Address: 0Fh

CON_CTRL3	B7	B6	B5	B4	B3	B2	B1	BO
Bit name and function	FPWM DCDC3	FPWM DCDC2	FPWM DCDC1	DCDC1 discharge	DCDC2 discharge	DCDC3 discharge	LDO1 discharge	LDO2 discharge
Default value loaded by:	UVLO	UVLO	UVLO	UVLO	UVLO	UVLO	UVLO	UVLO
Read/write	R/W	R/W	R/W	R/W	R/W	R/W	R/W	R/W

- Bit 7 FPWM DCDC3:
 0 = DCDC3 converter operates in PWM / PFM mode
 1 = DCDC3 converter is forced into fixed frequency PWM mode
- Bit 6 FPWM DCDC2:
 0 = DCDC2 converter operates in PWM / PFM mode
 1 = DCDC2 converter is forced into fixed frequency PWM mode
- Bit 5 FPWM DCDC1:
 0 = DCDC1 converter operates in PWM / PFM mode
 1 = DCDC1 converter is forced into fixed frequency PWM mode
- Bit 4–0 0 = the output capacitor of the associated converter or LDO is not actively discharged when the converter or LDO is disabled
 1 = the output capacitor of the associated converter or LDO is actively discharged when the converter or LDO is disabled. This decreases the fall time of the output voltage at light load

DEFDCDC1. Register Address: 10h

DEFDCDC1	B7	B6	B5	B4	B3	B2	B1	BO
Bit name and function	DCDC1 extadj		DCDC1[5]	DCDC1[4]	DCDC1[3]	DCDC1[2]	DCDC1[1]	DCDC1[0]
Default value loaded by:	UVLO	UVLO	UVLO	UVLO	UVLO	UVLO	UVLO	UVLO
Read/write	R/W	R	R/W	R/W	R/W	R/W	R/W	R/W

DEFDCDC1 sets the output voltage for the DCDC1 converter. Per default the converter is internally fixed but can be programmed to an externally adjustable version by setting Bit 7 (Ext adj). The default setting is defined in an EEPROM Bit. In case the externally adjustable version is programmed, the external resistor divider need to be connected to the VDCDC1 pin, otherwise this pin needs to be connected to the output voltage directly. For the fixed voltage version, the output voltage is set with Bits B0 to B5 (DCDC1[5] to DCDC1[0]):

All step-down converters provide the same output voltage range, see details under DEFDCDC3

DEFDCDC2_LOW. Register Address: 11h

DEFDCDC2_LOW	B7	B6	B5	B4	B3	B2	B1	B0
Bit name and function			DCDC2[5]	DCDC2[4]	DCDC2[3]	DCDC2[2]	DCDC2[1]	DCDC2[0]
Default value loaded by:			UVLO	UVLO	UVLO	UVLO	UVLO	UVLO
Read/write	R	R	R/W	R/W	R/W	R/W	R/W	R/W

DEFDCDC2_HIGH. Register Address: 12h

DEFDCDC2_HIGH	B7	B6	B5	B4	B3	B2	B1	B0
Bit name and function	DCDC2 extadj		DCDC2[5]	DCDC2[4]	DCDC2[3]	DCDC2[2]	DCDC2[1]	DCDC2[0]
Default value loaded by:	UVLO		UVLO	UVLO	UVLO	UVLO	UVLO	UVLO
Read/write	R/W	R	R/W	R/W	R/W	R/W	R/W	R/W

The output voltage for DCDC2 is switched between the value defined in DEFDCDC2_LOW and DEFDCDC2_HIGH depending on the status of the DEFDCDC2 pin. IF DEFDCDC2 is LOW the value in DEFDCDC2_LOW is selected, if DEFDCDC2 = HIGH, the value in DEFDCDC2_HIGH is selected. Per default the converter is internally fixed but can be programmed to an externally adjustable version by EEPROM similar to DCDC1.

DEFDCDC3_LOW. Register Address: 13h

DEFDCDC3_LOW	B7	B6	B5	B4	B3	B2	B1	B0
Bit name and function			DCDC3[5]	DCDC3[4]	DCDC3[3]	DCDC3[2]	DCDC3[1]	DCDC3[0]
Default value loaded by:			UVLO	UVLO	UVLO	UVLO	UVLO	UVLO
Read/write	R/W	R	R/W	R/W	R/W	R/W	R/W	R/W

DEFDCDC3_HIGH. Register Address: 14h

DEFDCDC3_HIGH	B7	B6	B5	B4	B3	B2	B1	B0
Bit name and function	DCDC3 extadj		DCDC3[5]	DCDC3[4]	DCDC3[3]	DCDC3[2]	DCDC3[1]	DCDC3[0]
Default value loaded by:	UVLO		UVLO	UVLO	UVLO	UVLO	UVLO	UVLO
Read/write	R/W	R	R/W	R/W	R/W	R/W	R/W	R/W

The output voltage for DCDC3 is switched between the value defined in DEFDCDC3_LOW and DEFDCDC3_HIGH depending on the status of the DEFDCDC3 pin. IF DEFDCDC3 is LOW the value in DEFDCDC3_LOW is selected, if DEFDCDC3 = HIGH, the value in DEFDCDC3_HIGH is selected. Per default the converter is internally fixed but can be programmed to an externally adjustable version by EEPROM similar to DCDC2.

OUTPUT VOLTAGE [V]	B5	B4	B3	B2	B1	B0
0.725	0	0	0	0	0	0
0.750	0	0	0	0	0	1
0.775	0	0	0	0	1	0
0.800	0	0	0	0	1	1
0.825	0	0	0	1	0	0
0.850	0	0	0	1	0	1
0.875	0	0	0	1	1	0
0.900	0	0	0	1	1	1

TPS65070-Q1, TPS65072-Q1, TPS65073-Q1, TPS650732-Q1

SLVSAP7 – JANUARY 2011

www.ti.com

OUTPUT VOLTAGE [V]	B5	B4	B3	B2	B1	B0
0.925	0	0	1	0	0	0
0.950	0	0	1	0	0	1
0.975	0	0	1	0	1	0
1.000	0	0	1	0	1	1
1.025	0	0	1	1	0	0
1.050	0	0	1	1	0	1
1.075	0	0	1	1	1	0
1.100	0	0	1	1	1	1
1.125	0	1	0	0	0	0
1.150	0	1	0	0	0	1
1.175	0	1	0	0	1	0
1.200	0	1	0	0	1	1
1.225	0	1	0	1	0	0
1.250	0	1	0	1	0	1
1.275	0	1	0	1	1	0
1.300	0	1	0	1	1	1
1.325	0	1	1	0	0	0
1.350	0	1	1	0	0	1
1.375	0	1	1	0	1	0
1.400	0	1	1	0	1	1
1.425	0	1	1	1	0	0
1.450	0	1	1	1	0	1
1.475	0	1	1	1	1	0
1.500	0	1	1	1	1	1
1.550	1	0	0	0	0	0
1.600	1	0	0	0	0	1
1.650	1	0	0	0	1	0
1.700	1	0	0	0	1	1
1.750	1	0	0	1	0	0
1.800	1	0	0	1	0	1
1.850	1	0	0	1	1	0
1.900	1	0	0	1	1	1
1.950	1	0	1	0	0	0
2.000	1	0	1	0	0	1
2.050	1	0	1	0	1	0
2.100	1	0	1	0	1	1
2.150	1	0	1	1	0	0
2.200	1	0	1	1	0	1
2.250	1	0	1	1	1	0
2.300	1	0	1	1	1	1
2.350	1	1	0	0	0	0
2.400	1	1	0	0	0	1
2.450	1	1	0	0	1	0
2.500	1	1	0	0	1	1
2.550	1	1	0	1	0	0
2.600	1	1	0	1	0	1
2.650	1	1	0	1	1	0
2.700	1	1	0	1	1	1

OUTPUT VOLTAGE [V]	B5	B4	B3	B2	B1	B0
2.750	1	1	1	0	0	0
2.800	1	1	1	0	0	1
2.850	1	1	1	0	1	0
2.900	1	1	1	0	1	1
3.000	1	1	1	1	0	0
3.100	1	1	1	1	0	1
3.200	1	1	1	1	1	0
3.300	1	1	1	1	1	1

DEFSLEW. Register Address: 15h

DEFSLEW	B7	B6	B5	B4	B3	B2	B1	B0
Bit name and function						SLEW2	SLEW1	SLEW0
Default	0	0	0	0	0	1	1	0
Default value loaded by:						UVLO	UVLO	UVLO
Read/write	R	R	R	R	R	R/W	R/W	R/W

The DEFSLEW register defines the slew rate of the output voltage for DCDC2 and DCDC3 in case the voltage is changed during operation. In case Bit “LDO2 tracking” in register DEF LDO2 is set, this is also valid for LDO2. When the voltage change is initiated by toggling pin DEFDCDC2 or DEFDCDC3, the start of the voltage change is triggered by the rising or falling edge of the DEFDCDC2 or DEFDCDC3 pin. If a voltage change is done internally by re-programming register DEFDCDC2_LOW, DEFDCDC2_HIGH, DEFDCDC3_LOW or DEFDCDC3_HIGH, the voltage change is initiated immediately after the new value has been written to the register with the slew rate defined.

SLEW2	SLEW1	SLEW0	VDCDC3 SLEW RATE
0	0	0	0.11 mV/μs
0	0	1	0.22 mV/μs
0	1	0	0.45 mV/μs
0	1	1	0.9 mV/μs
1	0	0	1.8 mV/μs
1	0	1	3.6 mV/μs
1	1	0	7.2 mV/μs
1	1	1	Immediate

LDO_CTRL1. Register Address: 16h

LDO_CTRL1	B7	B6	B5	B4	B3	B2	B1	B0
Bit name and function	LDO_SQ2	LDO_SQ1	LDO_SQ0		LDO1[3]	LDO1[2]	LDO1[1]	LDO1[0]
Default value loaded by:	UVLO	UVLO	UVLO		UVLO	UVLO	UVLO	UVLO
Read/write	R/W	R/W	R/W	R	R/W	R/W	R/W	R/W

Bit 7..5 LDO_SQ2 to LDO_SQ0: power-up sequencing: (power down sequencing is the reverse)

000 = LDO1 and LDO2 are enabled as soon as device is in ON-state by pulling $\overline{\text{PB_IN}}=\text{LOW}$ or $\text{POWER_ON}=\text{HIGH}$

001 = LDO1 and LDO2 are enabled after DCDC3 was enabled and its power good Bit is high.

010 = external pin at "EN_EXTLDO" is driven HIGH first, after >1ms LDO2 is enabled, LDO1 is enabled at the same time with DCDC3. EN_EXTLDO is driven LOW by going into OFF-state, LDO2 is disabled at the same time with EN_EXTLDO going LOW. Disabling LDO2 in register CON_CTRL1 will not drive EN_EXTLDO=LOW. (Atlas4)

011 = LDO1 is enabled 300us after PGOOD of DCDC1, LDO2 is off. LDO2 can be enabled/disabled by an I2C command in register CON_CTRL1.

100 = LDO1 is enabled after DCDC1 shows power good; LDO2 is enabled with DCDC3

101 = LDO1 is enabled with DCDC2; LDO2 is enabled after DCDC1 is enabled and its power good Bit is high

110 = LDO1 is enabled 10ms after DCDC2 is enabled and its power good Bit is high, LDO2 is off. LDO2 can be enabled / disabled by an I2C command in register CON_CTRL1.

111 = external pin at EN_EXTLDO is driven HIGH first, after >1ms LDO2 is enabled, LDO1 is enabled when EN_DCDC3 pin is pulled high AND DCDC3 is power good (first power-up from OFF state). LDO1 is disabled when EN_DCDC3 pin goes LOW for SLEEP mode. LDO2 is disabled at the same time with DCDC2 and DCDC1 during shutdown (Sirf PRIMA).

Automatic sequencing sets the enable Bits of the LDOs accordingly, so the LDOs can be enabled or disabled by the I2C interface in ON-state.

All sequencing options that define a ramp in sequence for the DCDC converters and the LDOs, (not at the same time) are timed such that the power good signal triggers the start for the next converter. If there is a time defined such as 1ms delay, the timer is started after the power good signal of the previous converter is high. LDO enable is delayed by 170us internally to match the delay for the DCDC converters. By this, for sequencing options that define a ramp at the same time for an LDO and a DCDC converter, it is made sure they will ramp at the same time, given the fact the DCDC converters have an internal 170us delay as well.

Bit 3..0 LDO1(3) to LDO1(0):

The Bits define the default output voltage of LDO1 according to the table below:

LDO1[3]	LDO1[2]	LDO1[1]	LDO1[0]	LDO1 OUTPUT VOLTAGE
0	0	0	0	1.0 V
0	0	0	1	1.1 V
0	0	1	0	1.2 V
0	0	1	1	1.25 V
0	1	0	0	1.3 V
0	1	0	1	1.35 V
0	1	1	0	1.4 V
0	1	1	1	1.5 V
1	0	0	0	1.6 V
1	0	0	1	1.8 V
1	0	1	0	2.5 V
1	0	1	1	2.75 V
1	1	0	0	2.8 V
1	1	0	1	3.0 V
1	1	1	0	3.1 V
1	1	1	1	3.3 V

DEFLDO2. Register Address: 17h

DEFLDO2	B7	B6	B5	B4	B3	B2	B1	B0
Bit name and function		LDO2 tracking	LDO2[5]	LDO2[4]	LDO2[3]	LDO2[2]	LDO2[1]	LDO2[0]
Default value loaded by:		UVLO	UVLO	UVLO	UVLO	UVLO	UVLO	UVLO
Read/write	R	R/W	R/W	R/W	R/W	R/W	R/W	R/W

The DEFLDO2 register is used to set the output voltage of LDO2 according to the voltage table defined under DEFDCDC3 when Bit LDO2 tracking is set to 0. In case Bit LDO2 tracking is set to 1, the output voltage of LDO2 is defined by the contents defined for DCDC3.

Bit 6 LDO2 TRACKING:

0 = the output voltage is defined by register DEFLDO2

1 = the output voltage follows the setting defined for DCDC3 (DEFDCDC3_LOW or DEFDCDC3_HIGH, depending on the state of pin DEFDCDC3)

Bit 5..0 LDO2[5] to LDO2[0]:

output voltage setting for LDO2 similar to DCDC3

WLED_CTRL1. Register Address: 18h

WLED_CTRL1	B7	B6	B5	B4	B3	B2	B1	BO
Bit name and function	Enable ISINK		Dimming frequency1	Dimming frequency0				
Default	0	0	0	1	0	0	0	0
Default value loaded by:	UVLO		UVLO	UVLO				
Read/write	R/W	R	R/W	R/W	R	R	R	R

Bit 7 **ENABLE ISINK:**
 0 = both current sinks are turned OFF, the wLED boost converter is disabled
 1 = both current sinks are turned on, the wLED boost converter is enabled

Bit 5..4 **DIMMING FREQUENCY 0/1:**
 00 = 100 Hz
 01 = 200 Hz
 10 = 500 Hz
 11 = 1000 Hz

WLED_CTRL2. Register Address: 19h

WLED_CTRL2	B7	B6	B5	B4	B3	B2	B1	BO
Bit name and function	Current level	LED DUTY CYCLE_6	LED DUTY CYCLE_5	LED DUTY CYCLE_4	LED DUTY CYCLE_3	LED DUTY CYCLE_2	LED DUTY CYCLE_1	LED DUTY CYCLE_0
Default	0	0	0	1	1	1	1	0
Default value loaded by:	UVLO	UVLO	UVLO	UVLO	UVLO	UVLO	UVLO	UVLO
Read/write	R/W	R/W	R/W	R/W	R/W	R/W	R/W	R/W

Bit 7 **CURRENT LEVEL:**
 0 = current defined with resistor connected from ISET2 to GND
 1 = current defined with resistor connected from ISET1 to GND

Bit 6..0 sets the duty cycle for PWM dimming from 1% (000000) to 100% (1100011).
 Values above 1100011 set the duty cycle to 0 %; default is 30% duty cycle

APPLICATION INFORMATION

STEP-DOWN CONVERTERS

OUTPUT FILTER DESIGN (INDUCTOR AND OUTPUT CAPACITOR)

Inductor Selection

The step-down converters operate typically with 2.2µH output inductor. Larger or smaller inductor values can be used to optimize the performance of the device for specific operation conditions. The selected inductor has to be rated for its DC resistance and saturation current. The DC resistance of the inductance will influence directly the efficiency of the converter. Therefore an inductor with lowest DC resistance should be selected for highest efficiency.

Equation 4 can be used to calculate the maximum inductor current under static load conditions. The saturation current of the inductor should be rated higher than the maximum inductor current as calculated with Equation 4. This is recommended because during heavy load transient the inductor current will rise above the calculated value.

$$\Delta I_L = V_{out} \times \frac{1 - \frac{V_{out}}{V_{in}}}{L \times f} \quad (4)$$

$$I_{Lmax} = I_{outmax} + \frac{\Delta I_L}{2} \quad (5)$$

With

f = Switching Frequency (2.25MHz typical)

L = Inductor Value

ΔI_L = Peak to Peak inductor ripple current

I_{Lmax} = Maximum Inductor current

The highest inductor current will occur at maximum V_{in}.

Open core inductors have a soft saturation characteristic and they can usually handle higher inductor currents versus a comparable shielded inductor.

A more conservative approach is to select the inductor current rating just for the maximum switch current of the corresponding converter. It must be considered, that the core material from inductor to inductor differs and will have an impact on the efficiency especially at high switching frequencies.

Refer to Table 4 and the typical applications for possible inductors.

Table 4. Tested Inductors

INDUCTOR TYPE	RECOMMENDED MAXIMUM DC CURRENT	INDUCTOR VALUE	SUPPLIER
LPS3010	0.6 A	2.2 µH	Coilcraft
LPS3015	1.2 A	2.2 µH	Coilcraft
LPS4018	1.5 A	2.2 µH	Coilcraft
VLCF4020	1.5 A	2.2 µH	TDK

Output Capacitor Selection

The advanced Fast Response voltage mode control scheme of the two converters allow the use of small ceramic capacitors with a typical value of 10µF, without having large output voltage under and overshoots during heavy load transients. Ceramic capacitors having low ESR values result in lowest output voltage ripple and are therefore recommended. Please refer to for recommended components.

If ceramic output capacitors are used, the capacitor RMS ripple current rating will always meet the application requirements. Just for completeness the RMS ripple current is calculated as:

$$I_{RMS\text{Cout}} = V_{\text{out}} \times \frac{1 - \frac{V_{\text{out}}}{V_{\text{in}}}}{L \times f} \times \frac{1}{2 \times \sqrt{3}} \quad (6)$$

At nominal load current the inductive converters operate in PWM mode and the overall output voltage ripple is the sum of the voltage spike caused by the output capacitor ESR plus the voltage ripple caused by charging and discharging the output capacitor:

$$\Delta V_{\text{out}} = V_{\text{out}} \times \frac{1 - \frac{V_{\text{out}}}{V_{\text{in}}}}{L \times f} \times \left(\frac{1}{8 \times C_{\text{out}} \times f} + \text{ESR} \right) \quad (7)$$

Where the highest output voltage ripple occurs at the highest input voltage V_{in} .

At light load currents the converters operate in Power Save Mode and the output voltage ripple is dependent on the output capacitor value. The output voltage ripple is set by the internal comparator delay and the external capacitor. The typical output voltage ripple is less than 1% of the nominal output voltage.

Input Capacitor Selection/Input Voltage

Because of the nature of the buck converter having a pulsating input current, a low ESR input capacitor is required for best input voltage filtering and minimizing the interference with other circuits caused by high input voltage spikes. The converters need a ceramic input capacitor of 10 μ F. The input capacitor can be increased without any limit for better input voltage filtering.

The input voltage for the step-down converters needs to be connected to pin VINDCDC1/2 for DCDC1 and DCDC2 and to pin VINDCDC3 for DCDC3. These pins need to be tied together to the power source on pin SYS (output of the power path). The 3 step-down converters must not be supplied from different input voltages.

Table 5. Possible Capacitors

22 μ F	0805	TDK C2012X5R0J226MT	Ceramic
22 μ F	0805	Taiyo Yuden JMK212BJ226MG	Ceramic
10 μ F	0805	Taiyo Yuden JMK212BJ106M	Ceramic
10 μ F	0805	TDK C2012X5R0J106M	Ceramic

Output Voltage Selection

The DEFDCDC2 and DEFDCDC3 pins are used to set the output voltage for step-down converter DCDC2 and DCDC3. See table 1 for the default voltages if the pins are pulled to GND or to Vcc.

Voltage Change on DCDC2 and DCDC3

The output voltage of DCDC2 and DCDC3 can be changed during operation from e.g. 1.0V to 1.2V (TPS65070) and back by toggling the DEFDCDC2 or DEFDCDC3 pin. The status of the DEFDCDC3 pin is sensed during operation and the voltage is changed as soon as the logic level on this pin changes from low to high or vice versa.

The output voltage for DCDC2 and DCDC3 can also be changed by changing the register content in registers DEFDCDC2_LOW, DEFDCDC2_HIGH, DEFDCDC3_LOW and DEFDCDC3_HIGH.

White-LED BOOST CONVERTER

LED-Current Setting/Dimming

The white LED boost converter generates an output voltage, high enough to drive current through up to 10 white LEDs connected in series. support one or two strings of white LEDs. If two strings of white LEDs are used, the number of LEDs in each string is limited to 6LEDs due to the switch current limit as defined in the electrical characteristics. The boost converter block contains two current sinks to control the current through the white LEDs. The anodes of the “upper” white-LEDs are directly connected to the output voltage at the output capacitor. The cathode of the “lowest” LED is connected to the input of the current sink at pin ISINK1 or ISINK2. The internal current sink controls the output voltage of the boost converter such that there is a minimum voltage at the current sink to regulate the defined current. The maximum current is set with a resistor connected from pin

ISET1 to GND. Dimming is done with an internal PWM modulator by changing the duty cycle in the current sinks from 1% to 100%. In order to set a LED current of less than 1% of the current defined at ISET1, a second current range is set with a resistor at pin ISET2 to GND. By changing between the two current ranges and varying the duty cycle, it is possible to achieve a dimming ratio of > 1:100. The main functions of the converter like enable / disable of the converter, PWM duty cycle and dimming frequency are programmed in registers WLED_CTRL1 and WLED_CTRL2 – see the register description for details.

If only one string of white LEDs are used, ISINK1 and ISINK2 need to be connected in parallel.

Setup

In applications not requiring the wLED boost converter, the pins should be tied to a GND as stated below:

Pins L4, FB_wLED, ISINK1 and ISINK2 should be directly connected to GND. Each ISET1 and ISET2 should be connected to GND with a 100k resistor. Optionally ISET1 and ISET2 can be used as analog inputs to the ADC. In this case, these pins can be tied to a voltage source in the range from 0V to 2.25V.

Setting the LED Current

There are two resistors which set the default current for the current sinks at ISINK1 and ISINK2.

The resistor connected to ISET1 is used if Bit CURRENT LEVEL is set 1 in register 19h.

The resistor connected to ISET2 is used if Bit CURRENT LEVEL is set 0 in register 19h (default).

This allows switching between two different maximum values for the LED current with one Bit to extend the resolution for dimming.

Dimming is done by an internal PWM signal that turns on and off the current sinks ISINK1 and ISINK2 at 200Hz (default). The duty cycle range is 1% to 100% with a 1% resolution and a default duty cycle of 30%. In order to get the full scale LED current, the PWM dimming needs to be set to 100% in register 19h. This is done by writing 63h to register 19h.

K_{ISET} is defined to be 1000 in the electrical spec, the reference voltage at ISET1 and ISET2 is 1.24V.

The current for each string is set by the resistor to:

$$ISINK1=ISINK2= K_{ISET} \times 1.24V/R_{ISETx} \quad (8) \quad (8)$$

$$R_{ISET1}, R_{ISET2} = K_{ISET} \times 1.24V/10mA=124 \text{ k}\Omega \quad (9) \quad (9)$$

A resistor value of 124 k Ω sets the current on each string to 10mA.

For one string of wLEDs, both strings need to be connected in parallel, so the current in the wLEDs is twice the current programmed by the resistor at ISET1 or ISET2.

Connecting both strings in parallel is required because the wLED converter generates its output voltage dependant on the current in ISINK1 and ISINK2. If the current falls below the target, the output voltage is increased. If one string is open, the wLED driver will boost the output voltage to its maximum because it assumes the voltage is not high enough to drive current into this string (there could be different numbers of wLEDs in the two strings).

Inductor Design

The inductor in a boost converter serves as an energy storage element. The energy stored equals $\frac{1}{2} L \times I^2$. Therefore, the inductor must not be saturated as the inductance will drop and the energy stored will be reduced causing bad efficiency. The converter operates with typically 15 μ H to 22 μ H inductors. A design example for an application powering 6LEDs in one string given below:

$V_{in} = 2.8 \text{ V}$ — minimum input voltage for the boost converter

$V_o = 6 \times 3.2 \text{ V} = 19.2 \text{ V}$ — assuming a forward voltage of 3.2V per LED

$V_f = 0.5 \text{ V}$ — forward voltage of the Schottky diode

$I_o = 25 \text{ mA}$ maximum LED current

$f_{sw} = 1.125 \text{ MHz}$ — switching frequency — $T=890\text{ns}$

$R_{ds(on)} = 0.6R$ — drain-source resistance of the internal NMOS switch

V_{sw} — voltage drop at the internal NMOS switch

I_{AVG} — average current in NMOS when turned on

The duty cycle for a boost converter is:

$$D = \frac{V_o + V_f - V_{in}}{V_o + V_f - V_{sw}} \quad (10)$$

With:

$$V_{sw} = R_{ds(on)} \times I_{AVG} \quad I_{avg} = \frac{I_o}{1 - D} \quad (11)$$

A different approach to calculate the duty cycle is based on the efficiency of the converter. The typical number can be found in the graphs, or as a first approach, we can assume to get an efficiency of about 80% as a typical value.

$$D \approx \left(1 - \eta \times \frac{V_i}{V_o + V_f} \right) \quad (12)$$

With the values given above

$$D \approx \left(1 - 0.8 \frac{2.8 \text{ V}}{19.2 \text{ V} + 0.5 \text{ V}} \right) \approx 89\% \quad (13)$$

$$t_{on} = T \times D = 890 \text{ ns} \times 0.89 = 792 \text{ ns}$$

$$t_{off} = 890 \text{ ns} - 792 \text{ ns} = 98 \text{ ns}$$

$$V_{sw} = R_{ds(on)} \times I_{AVG} = R_{ds(on)} \times \frac{I_o}{1 - D} = 0.6 \Omega \times \frac{25 \text{ mA}}{1 - 0.89} \approx 140 \text{ mV} \quad (14)$$

When the NMOS switch is turned on, the input voltage is forcing a current into the inductor. The current slope can be calculated with:

$$di = \frac{V_L \times dt}{L} = \frac{(V_{in} - V_{sw}) \times dt}{L} = \frac{(2.8 \text{ V} - 0.14 \text{ V}) \times 792 \text{ ns}}{18 \mu\text{H}} = 117 \text{ mA} \quad (15)$$

$$I_{avg} = \frac{I_o}{1 - D} = \frac{25 \text{ mA}}{1 - 0.89} = 227 \text{ mA} \quad (16)$$

The minimum and maximum inductor current can be found by adding half of the inductor current ripple (di) to the average value, which gives:

$$I_{max} = 227 \text{ mA} + \frac{117 \text{ mA}}{2} = 285 \text{ mA}$$

$$I_{min} = 227 \text{ mA} - \frac{117 \text{ mA}}{2} = 169 \text{ mA} \quad (17)$$

Given the values above, an inductor with a current rating greater than 290mA is needed. Plenty of margin should be kept to the rating in the inductor vendors data sheets as the maximum current is typically specified at a inductance drop of 20% or even 30%. A list of tested inductors is given in [Table 6](#) with the test conditions as mentioned below.

Test conditions:

- $V_{in} = 2.8 \text{ V}$
- $V_f = 3.2 \text{ V}$ (per LED)
- $V_f = 0.5 \text{ V}$ (Schottky diode)
- $I_{out} = 25 \text{ mA}$ per string; no dimming

Table 6. Tested Inductors

LED CONFIGURATION	INDUCTOR TYPE	INDUCTOR VALUE	SUPPLIER
1 × 6LEDs	LPS3015	18 μH	Coilcraft
2 × 6LEDs	LPS4018	47 μH	Coilcraft
1 × 10LEDs	LPS4018	47 μH	Coilcraft

Other inductors, with lower or higher inductance values can be used. A higher inductance will cause a lower inductor current ripple and therefore will provide higher efficiency. The boost converter will also stay in continuous conduction mode over a wider load current range. The energy stored in an inductor is given by $E = 1/2L \times I^2$ where I is the peak inductor current. The maximum current in the inductor is limited by the internal current limit of the device, so the maximum power is given by the minimum peak current limit (see electrical specifications) times the inductance value. For highest output power, a large inductance value is needed. The minimum inductor value possible is limited by the energy needed to supply the load. The limit for the minimum inductor value is given during the on-time of the switch such that the current limit is not reached.

Example for the minimum inductor value:

$$\begin{aligned} V_{in} &= 4.2 \text{ V}, V_{out} = 19.7 \text{ V}, I_{out} = 5 \text{ mA}, V_{sw} = 0.1 \text{ V} \\ \rightarrow D &= 79\% \\ \rightarrow t_{on} &= 703 \text{ ns} \end{aligned}$$

During the on-time, the inductor current should not reach the current limit of 1.4 A.

With V_{L} voltage across the inductor ($V = V_{in} - V_{sw}$)

$$\rightarrow L = V \times dt/di = (4.2 \text{ V} - 0.1 \text{ V}) \times 703 \text{ ns} / 1.4 \text{ A} = 2 \mu\text{H}$$

Diode Selection

Due to the non-synchronous design of the boost converter, an external diode is needed. For best performance, a Schottky diode with a voltage rating of 40V or above should be used. A diode such as the MBR0540 with an average current rating of 0.5A is sufficient.

Output Capacitor Selection

A ceramic capacitor such as X5R or X7R type is required at the output. See [Table 7](#) for reference.

Table 7. Tested Capacitor

LED CONFIGURATION	TYPICAL VOLTAGE ACROSS OUTPUT CAPACITOR	CAPACITOR VALUE	CAPACITOR SIZE	CAPACITOR TYPE	MANUFACTURER
2x6LEDs or 1x6LEDs	21 V	4.7 μF / 50 V	1206	UMK316BJ475KL	Taiyo Yuden
1x10LEDs	35 V	4.7 μF / 50 V	1210	GRM32ER71H475KA	Murata

Input Capacitor Selection

A small ceramic input capacitor of 10 μF is needed at the input of the boost converter. If the inductor is directly connected to the SYS output of , the capacitor can be shared. In this case the capacitance needs to be 22 μF or above. Only X5R or X7R ceramic capacitors should be used.

BATTERY CHARGER

Temperature Sensing

The battery charger integrated in has an over temperature protection for the Li-ion cell. The temperature is sensed with a NTC located at the battery. Comparators in suspend charge at a temperature below 0°C and above 45°C. The charger supports two different resistor values for the NTC. The default is internally programmed to 10k. It is possible to change to a 100k NTC with the I2C interface.

Table 8. NTCs Supported

RESISTANCE AT 25°C	CURVE / B VALUE	RT2 NEEDED FOR LINEARIZATION	MANUFACTURER
10k	Curve 2 / B=3477	75k	Several
100k	Curve 1 / B=3964	370k	Several

For best performance, the NTC needs to be linearized by connecting a resistor (RT2) in parallel to the NTC as shown in [Figure 46](#). The resistor value of RT2 needed for linearization can be found in [Table 8](#).

If the battery charger needs to be operated without a NTC connected, e.g. for test purposes, a resistor of 10k or 100k needs to be connected from TS to GND, depending for which NTC is configured to in register CHCONFIG1.

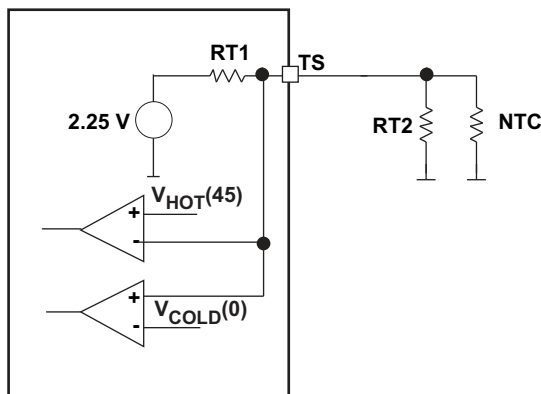

Figure 45. Linearizing the NTC

Changing the Charging Temperature Range (Default 0°C to 45°C)

The battery charger is designed to operate with the two NTCs listed above. These will give a cold and hot temperature threshold of 0°C and 45°C. If the charger needs to operate (charge) in a wider temperature range e.g. -5°C to 50°C, the circuit can be modified accordingly. The NTC changes its resistance based on the equation listed below:

$$R_{NTC}(T) = R_{25} \times e^{\left(B \times \left(\frac{1}{T} - \frac{1}{T_0} \right) \right)} \quad (18)$$

With:

- R25 = NTC resistance at 25°C
- T = temperature in Kelvin
- T0 = reference temperature (298K)

Resistor RT2 in parallel to the NTC is used to linearize the resistance change with temperature of the NTC. As the NTC has a high resistance at low temperature, the resulting resistance of NTC in parallel with RT2 is lower especially for low temperatures where the NTC has a high resistance, so RT2 in parallel has a significant impact. For higher temperatures, the resistance of the NTC dropped significantly, so RT2 in parallel does not change the resulting resistance a lot. See [Figure 46](#).

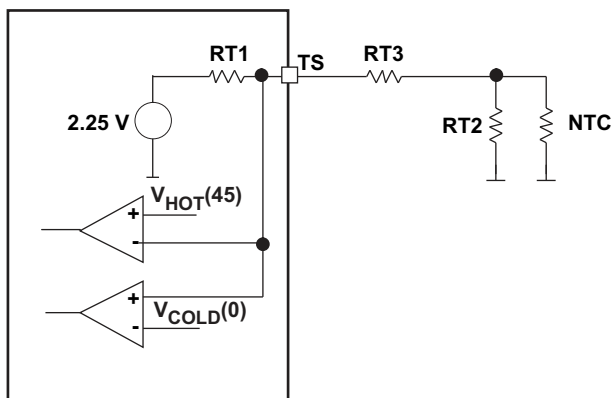

Figure 46. Changing the Temperature Range

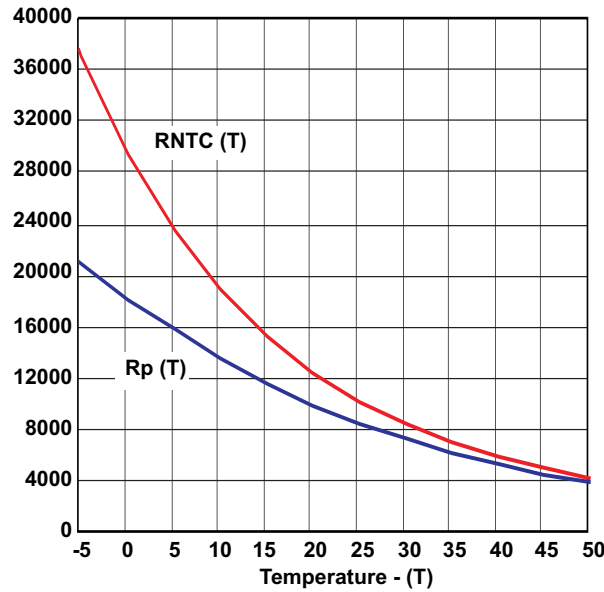

Figure 47. NTC [R(T)] and NTC in Parallel to RT2 [Rges(T)]

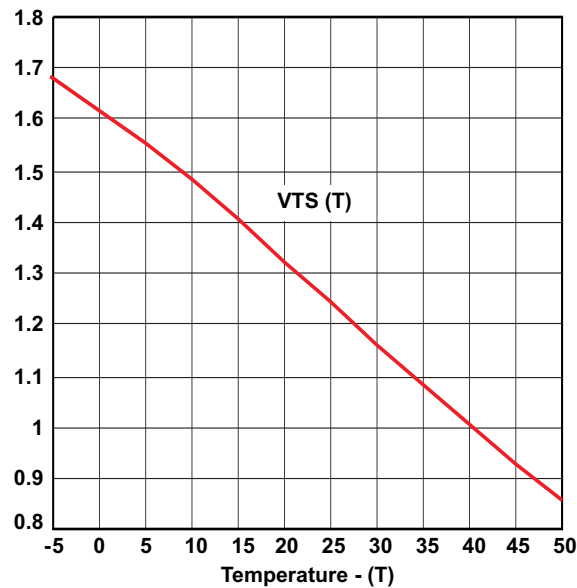

Figure 48. Resulting TS Voltage

As Figure 47 shows, the result is an extended charging temperature range at lower temperatures. The upper temperature limit is shifted to lower values as well resulting in a V(HOT) temperature of slightly less than 45°C. Therefore RT3 is needed to shift the temperature range to higher temperatures again. Figure 48 shows the result for:

- RT2 = 47k
- RT3 = 820R

Using these values will extend the temperature range for charging to -5°C to 50°C.

POWER SOLUTIONS FOR DIFFERENT APPLICATION PROCESSORS

Default Settings

For proper power supply design with , not only the default output voltage is relevant but also in what sequence the different power rails are enabled. The voltages are typically enabled internally based on the sequencing options programmed. For different application processors, there are different sequencing options available. In addition, the delay time and pulse for the reset signal to the application processor is different. See [Table 9](#) with the default settings for sequencing, output voltages and reset options for the family:

Table 9. Sequencing Settings

	DEDICATED FOR	DCDC_SQ[2..0]	LDO_SQ[2..0]	COMMENT
--	---------------	---------------	--------------	---------

Starting

was developed for battery powered applications with focus on lowest shutdown and quiescent current. In order to achieve this, in shutdown all mayor blocks and the system voltage at the output of the power path (SYS) are turned off and only the input that turns on , pin $\overline{\text{PB_IN}}$, is supervised. is designed such that only an ON-key on $\overline{\text{PB_IN}}$ is needed pulling this pin LOW to enable . No external pull-up is needed as this is integrated into .

Once $\overline{\text{PB_IN}}$ is pulled LOW, the system voltage is ramped and the dcdc converters and LDOs are started with the sequencing defined for the version used. If $\overline{\text{PB_IN}}$ is released again, TPS6507x would turn off, so a pin was introduced to keep TPS6507x enabled after $\overline{\text{PB_IN}}$ was released. Pin $\overline{\text{POWER_ON}}$ serves this function and needs to be pulled HIGH before the user releases the ON-key ($\overline{\text{PB_IN}} = \text{HIGH}$). This HIGH signal at $\overline{\text{POWER_ON}}$ can be provided by the GPIO of a processor or by a pull-up resistor to any voltage in the system which is higher than 1.2V. Pulling $\overline{\text{POWER_ON}}$ to a supply voltage would significantly reduce the time $\overline{\text{PB_IN}}$ has to be asserted LOW. If $\overline{\text{POWER_ON}}$ is tied to a GPIO, the processor has to boot up first which may take some time. In this case however, the processor could do some additional debouncing, hence does not keep the power enabled if the ON-key is only pressed for a short time. When there is a supply voltage for the battery charger at pins AC or USB, the situation is slightly different. In this case, the power path is enabled and the system voltage (SYS) has ramped already to whatever the voltage at AC or USB is. The dcdc converters are not enabled yet but the start-up could not only be done by pulling $\overline{\text{PB_IN}} = \text{LOW}$ but also by pulling $\overline{\text{POWER_ON}} = \text{HIGH}$.

In applications that do not require an ON-key but shall power-up automatically once supply voltage is applied, there are two cases to consider. If TPS6507x is powered from its AC or USB pin (not powered from its BAT pin), $\overline{\text{POWER_ON}}$ just needs to be pulled HIGH to enable the converters. $\overline{\text{PB_IN}}$ must not be tied LOW in this case.

If TPS6507x is powered from its BAT pin, $\overline{\text{PB_IN}}$ needs to be tied LOW to start-up the converters.

Layout Considerations

As for all switching power supplies, the layout is an important step in the design. Proper function of the device demands careful attention to PCB layout. Care must be taken in board layout to get the specified performance. If the layout is not carefully done, the regulators may show poor line and/or load regulation, and stability issues as well as EMI problems. It is critical to provide a low impedance ground path. Therefore, use wide and short traces for the main current paths. The input capacitors should be placed as close as possible to the IC pins as well as the inductor and output capacitor.

For TPS6507x, connect the PGND pin of the device to the PowerPAD™ land of the PCB and connect the analog ground connection (GND) to the PGND at the PowerPAD™. The PowerPAD™ serves as the power ground connection for the DCDC1 and DCDC2 converters. Therefore it is essential to provide a good thermal and electrical connection to GND using multiple vias to the GND-plane. Keep the common path to the GND pin, which returns the small signal components, and the high current of the output capacitors as short as possible to avoid ground noise. The VDCDCx line should be connected right to the output capacitor and routed away from noisy components and traces (for example, the L1, L2, L3 and L4 traces). See the EVM users guide for details about the layout for TPS6507x.

APPLICATION CIRCUITS

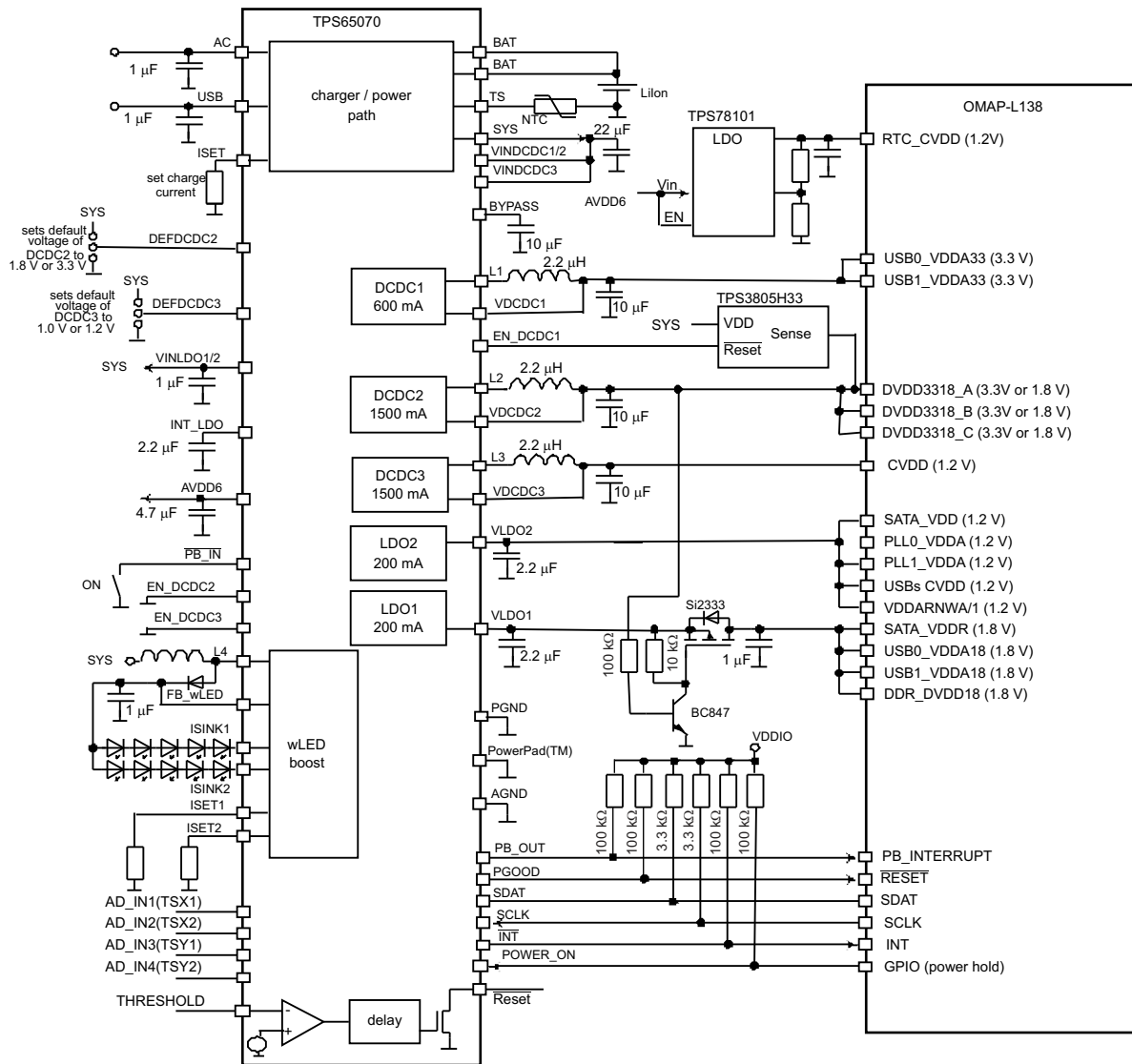

Figure 49. Powering OMAP-L138

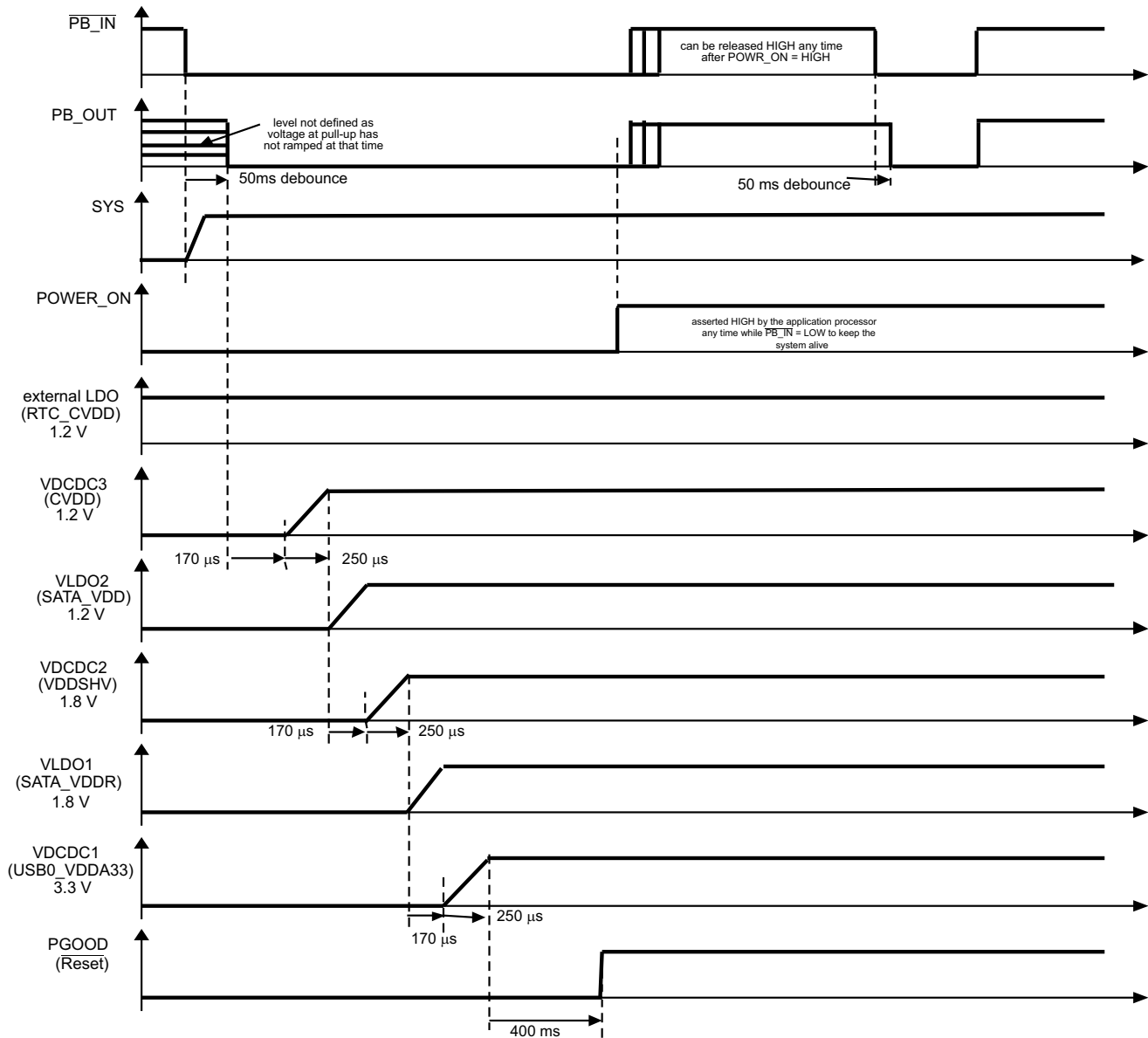
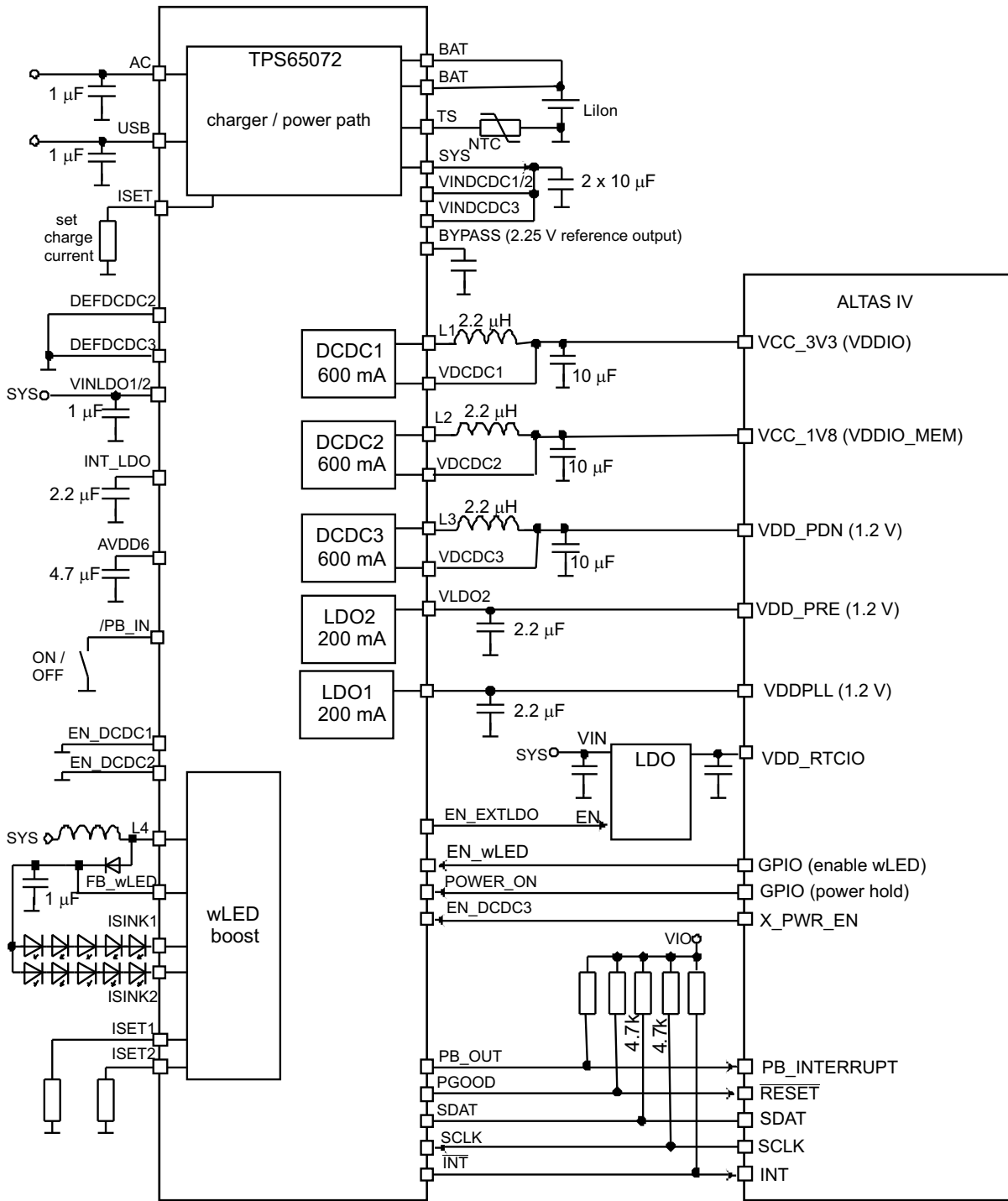

Figure 50. Timing for OMAP-L138



Note: /Reset to Atlas 4 may need to be a RC delay from VDDIO

Figure 51. Powering Atlas IV

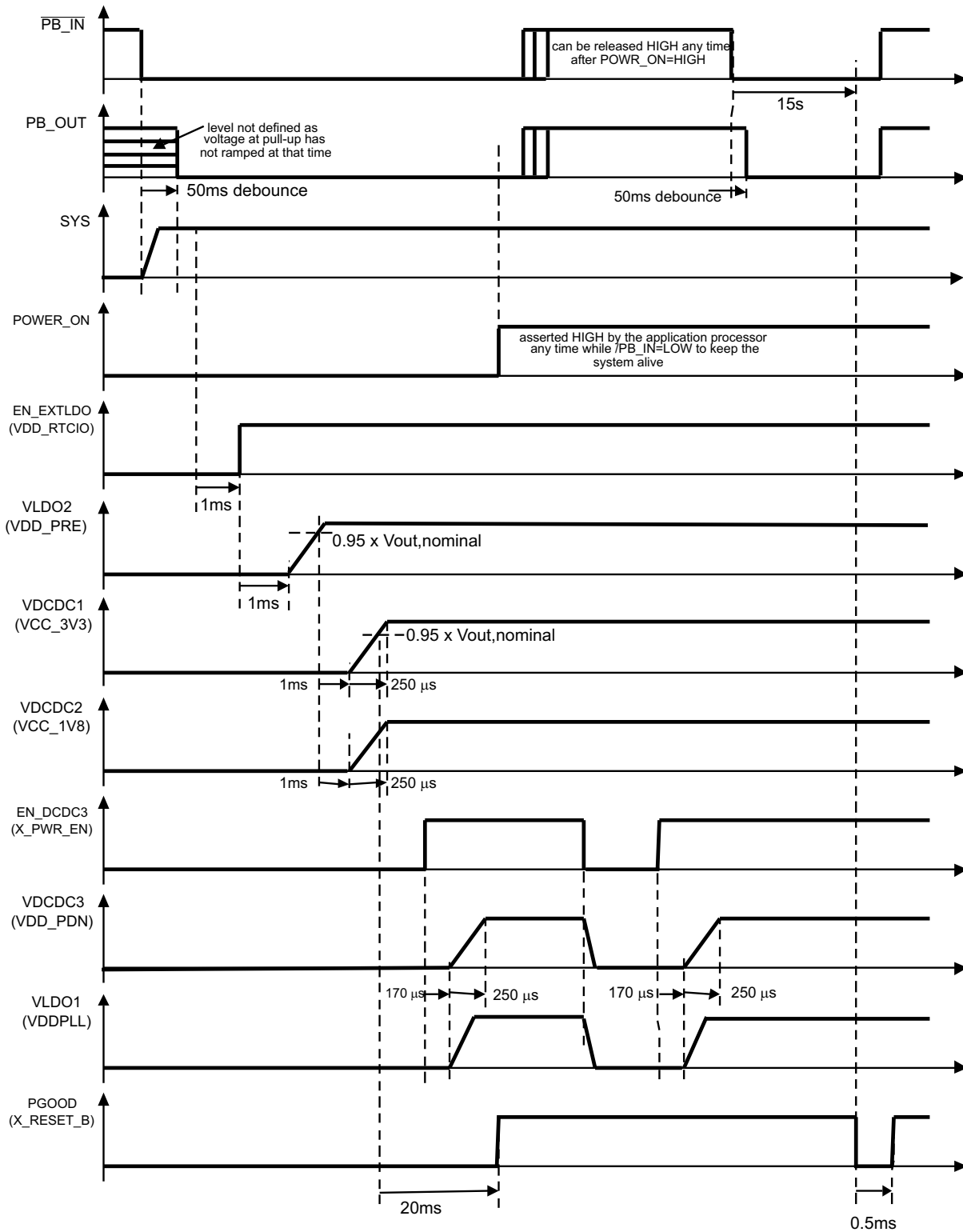

Figure 52. Timing for Atlas IV

Prima SLEEP Mode and DEEP SLEEP Mode Support

TPS6507x contains a sequencing option for the Sifir Prima processor. The sequencing option defines how the voltages are ramped at initial power-up and shutdown as well as the timing for entering power save mode for the processor (SLEEP mode). The Prima processor supports SLEEP mode and also DEEP SLEEP mode. The main difference from a power supply point of view is:

- How the supply voltages are turned off
- Which voltages are turned off
- How power save mode is exited into normal mode
- Reset asserted or not (PGOOD pin of TPS6507x going actively low)

The sequencing option for Prima is defined in one register each for the sequencing of the DCDC converters and for the LDOs. DCDC_SQ[2..0]=100 in register CON_CTRL1 defines the startup sequence for the DCDC converters while LDO_SQ[2..0]=111 defines the sequence for the LDOs. The default is factory programmed therefore it is ensured the first power-up is done in the right sequence.

When TPS6507x is off, a small state machine supervises the status of pin PB_IN while major blocks are not powered for minimum current consumption from the battery as long as there is no input voltage to the charger. Power-up for the TPS6507x is started by $\overline{\text{PB_IN}}$ going LOW. This will turn on the power-FET from the battery so the system voltage (SYS) is rising and the main blocks of the PMU are powered. After a debounce time of 50ms, the main state machine will pull PB_OUT = LOW to indicate that there is a “keypress” by the user and will ramp the DCDC converters and LDOs according to the sequence programmed. It is important to connect the power rails for the processor to exactly the dcDC converters and LDOs as shown in the schematic and sequencing diagrams for proper sequencing. For Prima, the voltage rails for VDD_RTCIO needs to ramp first. This power rail is not provided by the PMU but from an external LDO which is enabled by a signal called EN_EXTLDO from the PMU. The PMU will therefore first rise the logic level on pin EN_EXTLDO high to enable the external LDO. After a 1ms delay the PMU will ramp LDO2 for VDD_PRE and DCDC3 for VDD_PDN. When the output voltage of LDO2 is within its nominal range the internal power good comparator will trigger the state machine which will ramp DCDC1 and DCDC2 to provide the supply voltage for VCC_3V3 and VCC_1V8. Now Prima needs to pull its X_PWR_EN signal high which drives EN_DCDC3 on the PMU. This will now enable LDO1 to power VDDPLL. X_RESET_B will be released by the PMU on pin PGOOD based on the voltage of DCDC1 after a delay of 20ms.

SLEEP Mode

At first power-up (start-up from OFF state), the voltage for VDD_PDN is ramped at the same time than VDD_PRE. This is defined by Bit MASK_EN_DCDC3 in register CON_CTRL2 which is “1” per default. For enabling SLEEP mode, Prima needs to clear this Bit, so the EN_DCDC3 pin takes control over the DCDC3 converter. Prima SLEEP mode is initialized by Prima pulling its X_PWR_EN pin LOW which is driving the EN_DCDC3 pin of TPS6507x. This will turn off the power for VDDPLL (LDO1) and also for VDD_PDN (DCDC3). All other voltage rails will stay on. Based on a “keypress” with PB_OUT going LOW, Prima will wake up and assert EN_DCDC3=HIGH. This will turn DCDC3 and LDO1 back on and Sifir PRIMA will enter normal operating mode.

DEEP SLEEP Mode

Entry into DEEP SLEEP mode is controlled by Prima by writing to register CON_CTRL2 of TPS6507x. Before entering DEEP SLEEP mode, Prima will back up all memory and set Bit DS_RDY=1 to indicate the memory was saved and the content is valid. Setting PWR_DS=1 will turn off all voltage rails except DCDC2 for the memory voltage and the PMU will apply a reset signal by pulling PGOOD=LOW. Prima can not detect logic level change by PB_OUT going low in DEEP SLEEP mode. A wakeup from DEEP sleep is therefore managed by the PMU. The PMU will clear Bit PWR_DS and turn on the converters again based on a user “keypress” when PB_IN is being pulled LOW. Prima will now check if DS_RDY=1 to determine if the memory content is still valid and clear the Bit afterwards. In case there is a power loss and the voltage of the PMU is dropping below the undervoltage lockout threshold, the registers in the PMU are re-set to the default and DS_RDY is cleared. The PMU would perform a start-up from OFF state instead of exit from DEEP SLEEP and Sifir PRIMA would read DS_RDY=0, which indicates memory data is not valid.

See timing diagrams for Sifir Prima SLEEP and DEEP SLEEP in [Figure 53](#) and [Figure 54](#).

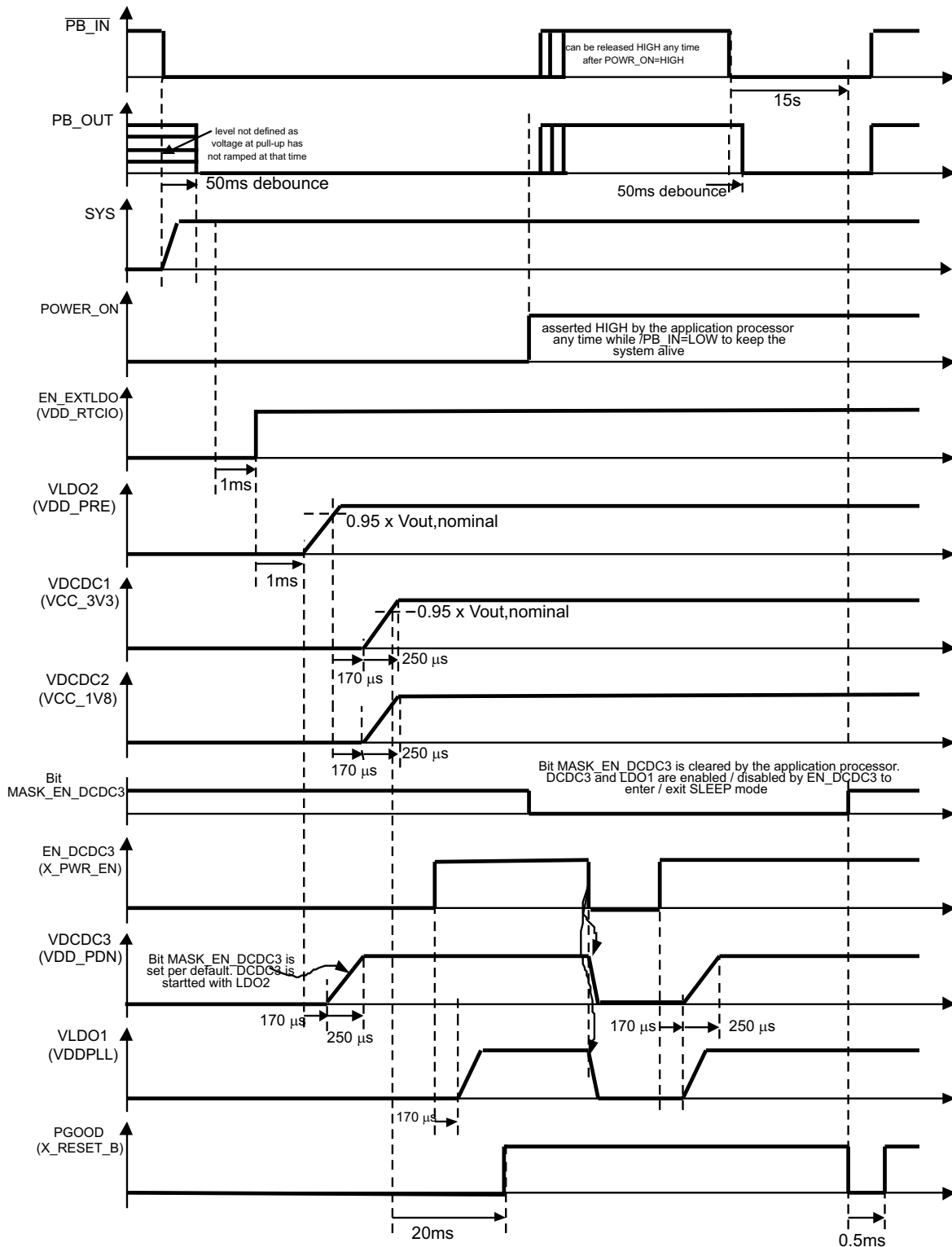

Figure 53. Timing for Sirf Prima SLEEP Mode

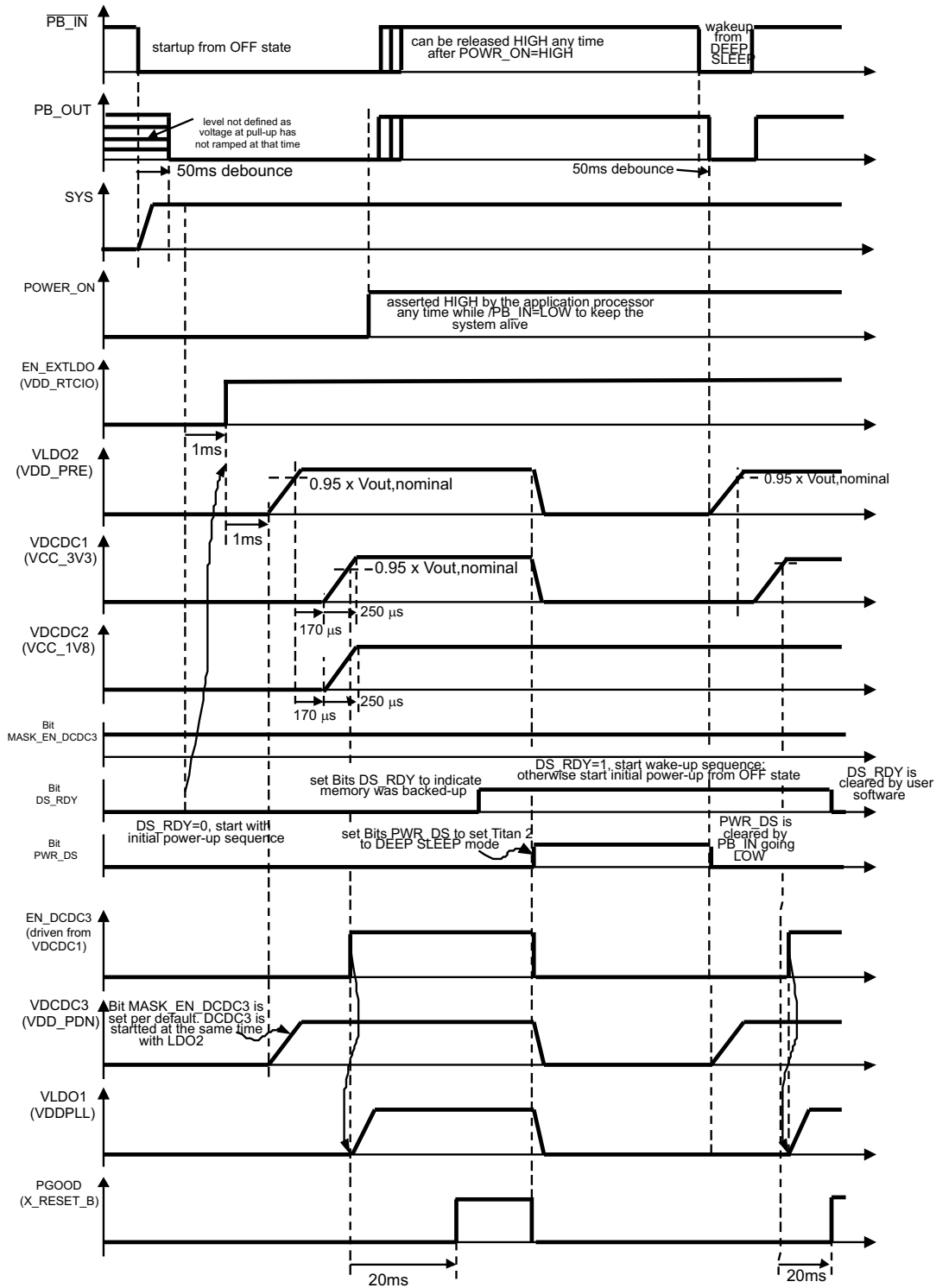

Figure 54. Timing for Sirf Prima DEEP SLEEP Mode

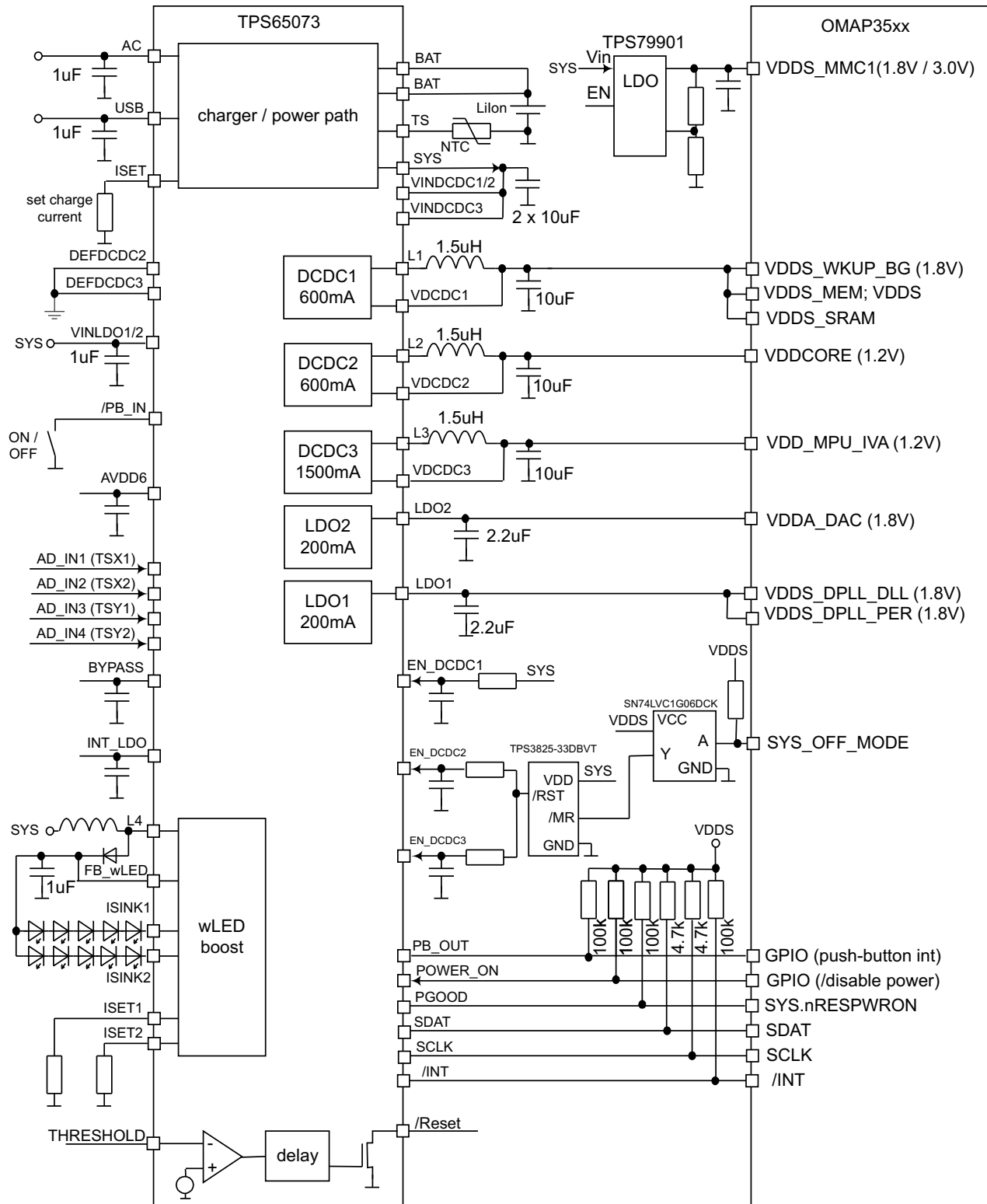

Figure 55. OMAP35xx (Supporting SYS-OFF Mode)

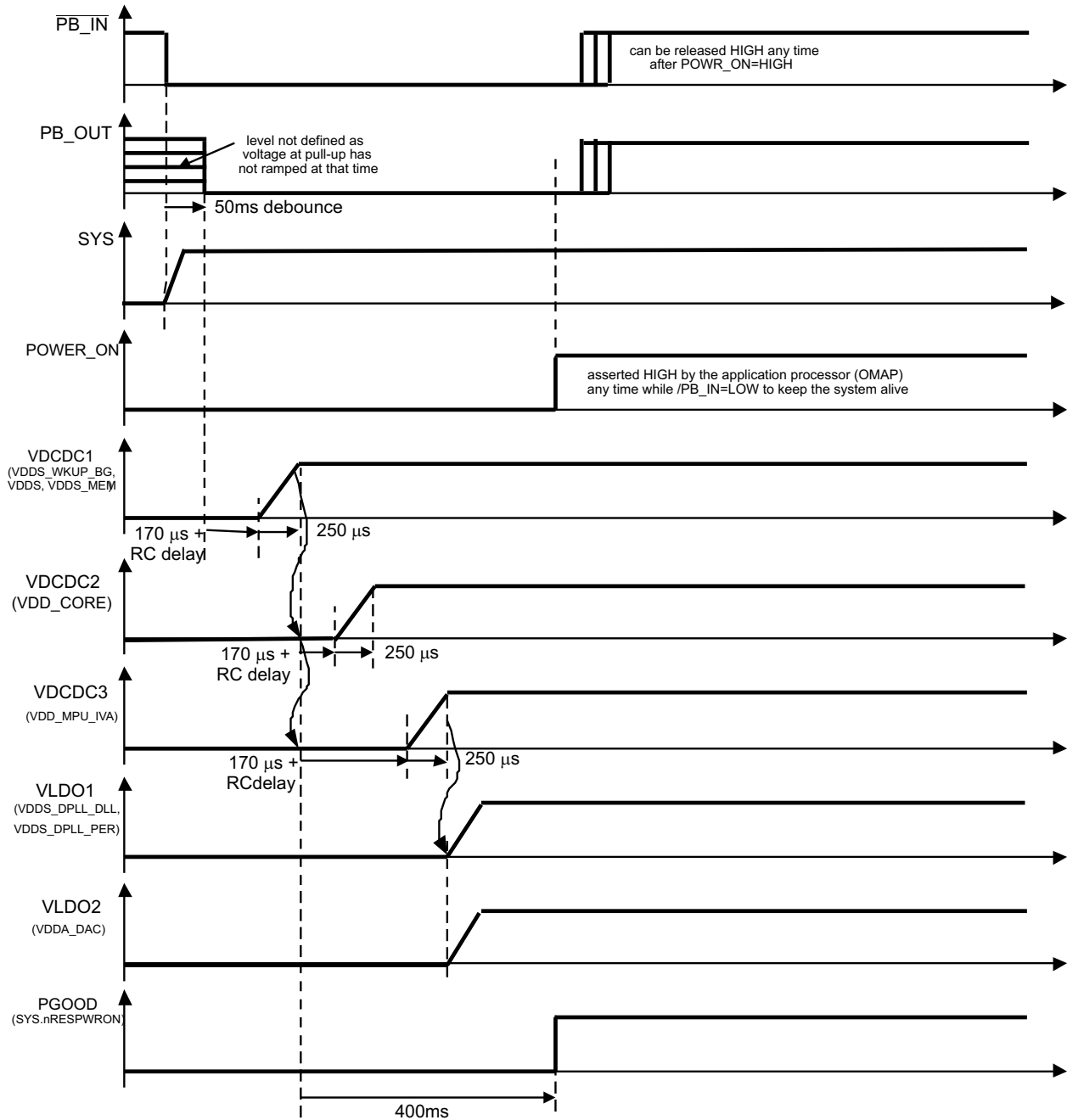

Figure 56. OMAP35xx Timing (Supporting SYS-OFF Mode)

TPS65070-Q1, TPS65072-Q1, TPS65073-Q1, TPS650732-Q1

SLVSAP7 – JANUARY 2011

www.ti.com

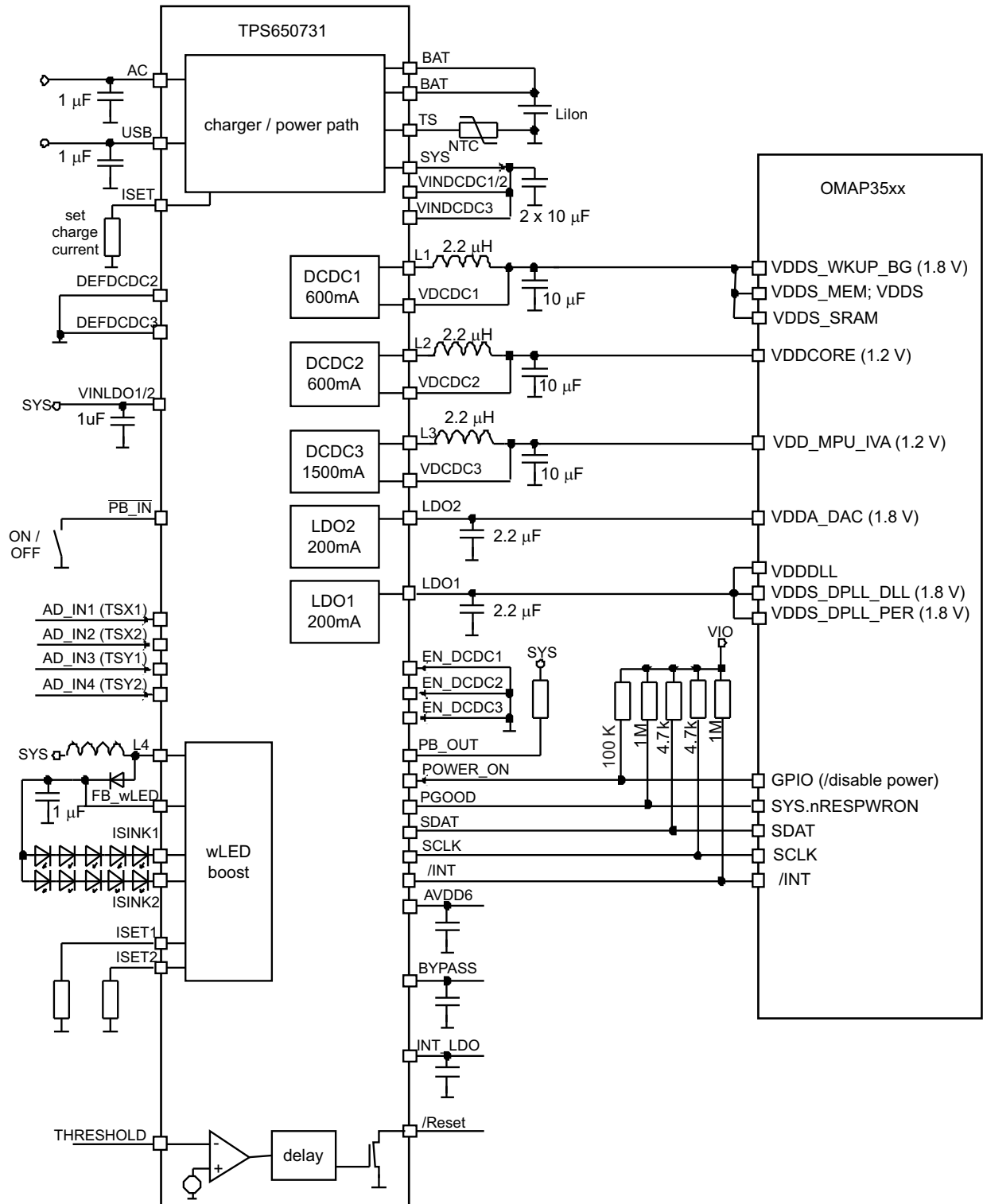

Figure 57. TPS650731 for OMAP35xx

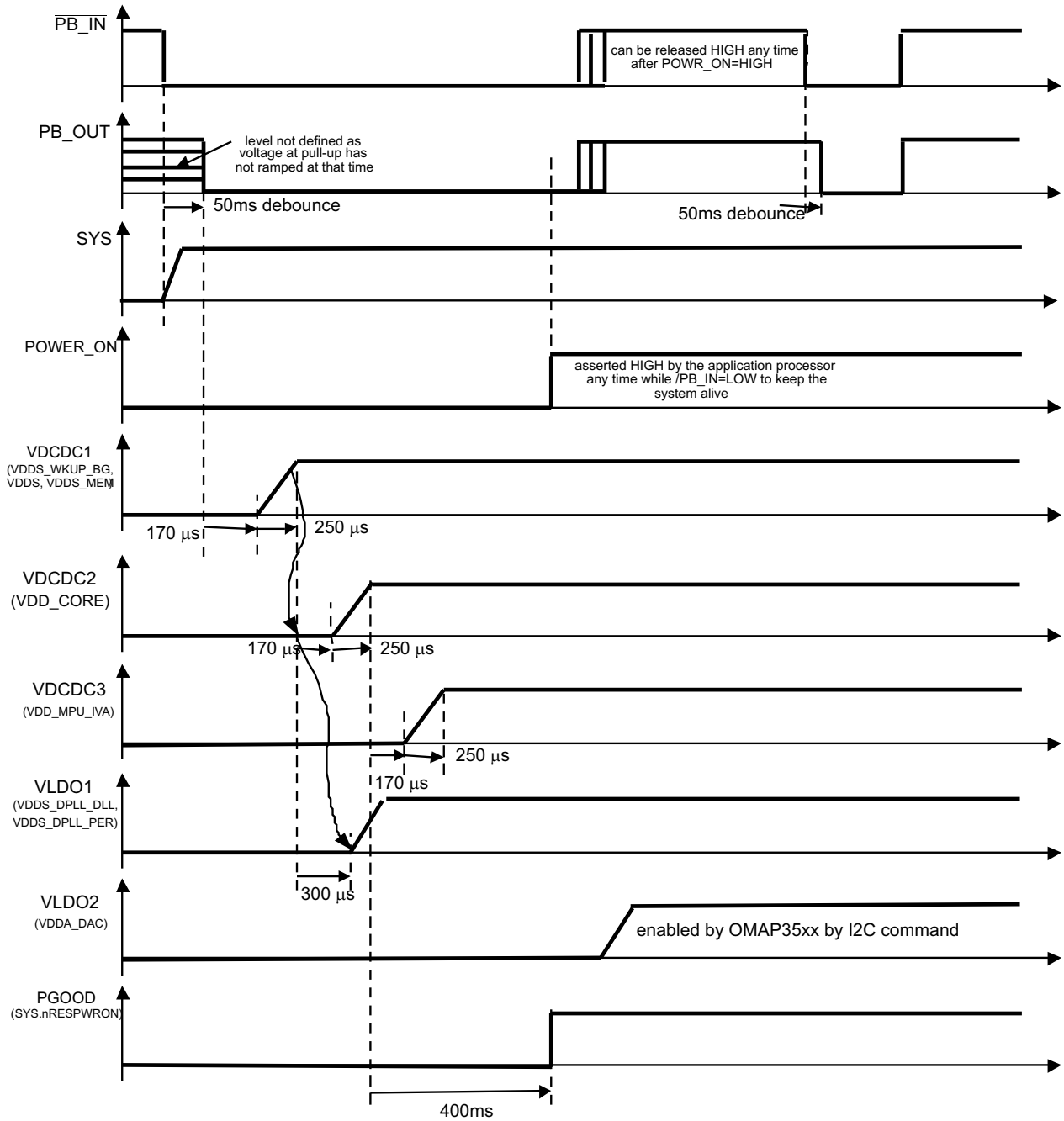

Figure 58. TPS650731: OMAP35xx timing

TPS65070-Q1, TPS65072-Q1, TPS65073-Q1, TPS650732-Q1

SLVSAP7 – JANUARY 2011

www.ti.com

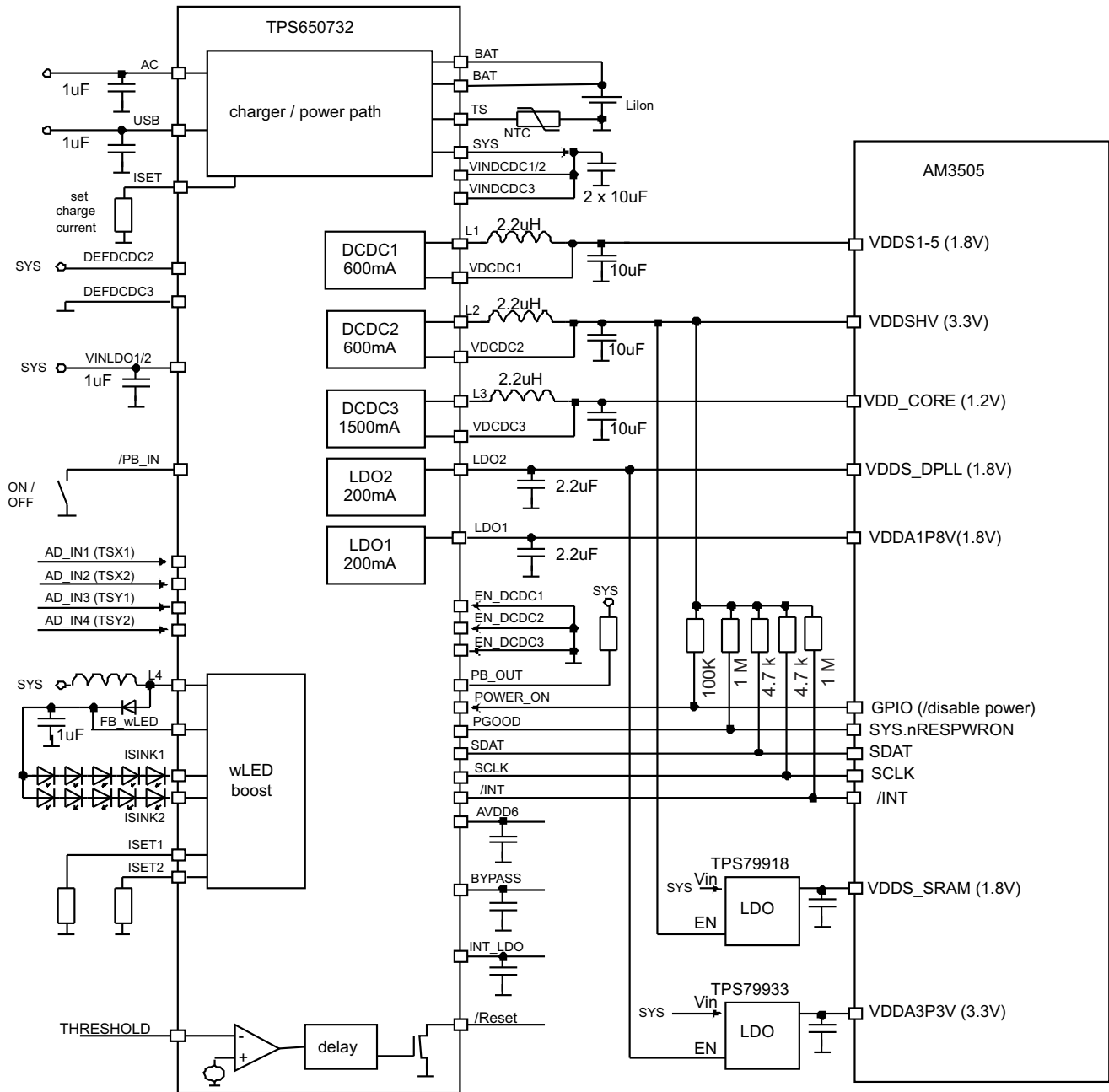

Figure 59. Powering AM3505 Using TPS650732

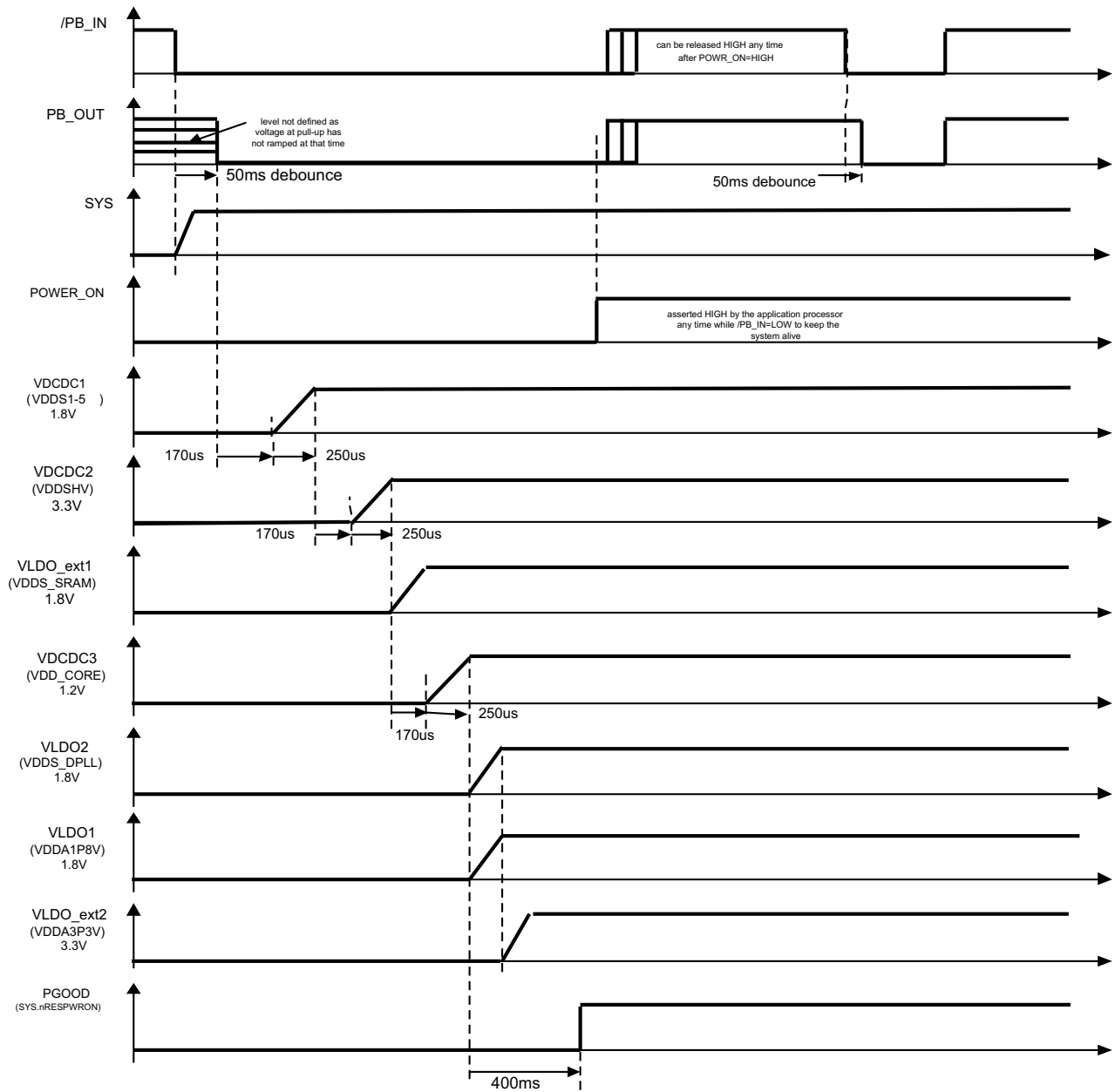

Figure 60. Timing Using TPS650732 for AM3505

PACKAGING INFORMATION

Orderable Device	Status (1)	Package Type	Package Drawing	Pins	Package Qty	Eco Plan (2)	Lead finish/ Ball material (6)	MSL Peak Temp (3)	Op Temp (°C)	Device Marking (4/5)	Samples
TPS650732TRSLRQ1	ACTIVE	VQFN	RSL	48	2500	RoHS & Green	NIPDAU	Level-3-260C-168 HR	-40 to 105	TPS 650732T	Samples

(1) The marketing status values are defined as follows:

ACTIVE: Product device recommended for new designs.

LIFEBUY: TI has announced that the device will be discontinued, and a lifetime-buy period is in effect.

NRND: Not recommended for new designs. Device is in production to support existing customers, but TI does not recommend using this part in a new design.

PREVIEW: Device has been announced but is not in production. Samples may or may not be available.

OBSOLETE: TI has discontinued the production of the device.

(2) **RoHS:** TI defines "RoHS" to mean semiconductor products that are compliant with the current EU RoHS requirements for all 10 RoHS substances, including the requirement that RoHS substance do not exceed 0.1% by weight in homogeneous materials. Where designed to be soldered at high temperatures, "RoHS" products are suitable for use in specified lead-free processes. TI may reference these types of products as "Pb-Free".

RoHS Exempt: TI defines "RoHS Exempt" to mean products that contain lead but are compliant with EU RoHS pursuant to a specific EU RoHS exemption.

Green: TI defines "Green" to mean the content of Chlorine (Cl) and Bromine (Br) based flame retardants meet JS709B low halogen requirements of <=1000ppm threshold. Antimony trioxide based flame retardants must also meet the <=1000ppm threshold requirement.

(3) MSL, Peak Temp. - The Moisture Sensitivity Level rating according to the JEDEC industry standard classifications, and peak solder temperature.

(4) There may be additional marking, which relates to the logo, the lot trace code information, or the environmental category on the device.

(5) Multiple Device Markings will be inside parentheses. Only one Device Marking contained in parentheses and separated by a "~" will appear on a device. If a line is indented then it is a continuation of the previous line and the two combined represent the entire Device Marking for that device.

(6) Lead finish/Ball material - Orderable Devices may have multiple material finish options. Finish options are separated by a vertical ruled line. Lead finish/Ball material values may wrap to two lines if the finish value exceeds the maximum column width.

Important Information and Disclaimer:The information provided on this page represents TI's knowledge and belief as of the date that it is provided. TI bases its knowledge and belief on information provided by third parties, and makes no representation or warranty as to the accuracy of such information. Efforts are underway to better integrate information from third parties. TI has taken and continues to take reasonable steps to provide representative and accurate information but may not have conducted destructive testing or chemical analysis on incoming materials and chemicals. TI and TI suppliers consider certain information to be proprietary, and thus CAS numbers and other limited information may not be available for release.

In no event shall TI's liability arising out of such information exceed the total purchase price of the TI part(s) at issue in this document sold by TI to Customer on an annual basis.

OTHER QUALIFIED VERSIONS OF TPS650732-Q1 :

- Catalog: [TPS650732](#)

NOTE: Qualified Version Definitions:

- Catalog - TI's standard catalog product

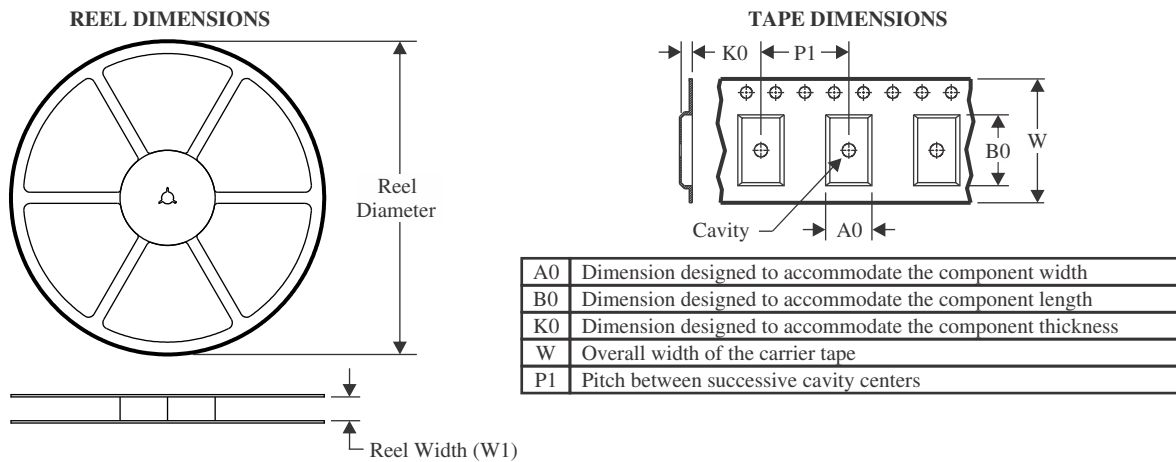
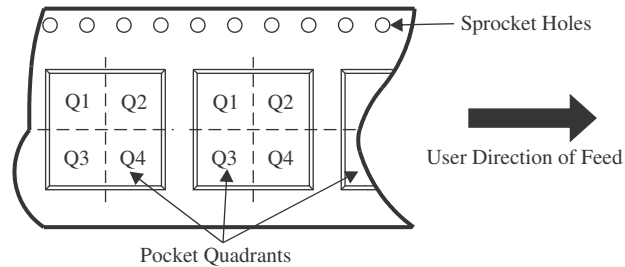
TAPE AND REEL INFORMATION

QUADRANT ASSIGNMENTS FOR PIN 1 ORIENTATION IN TAPE

*All dimensions are nominal

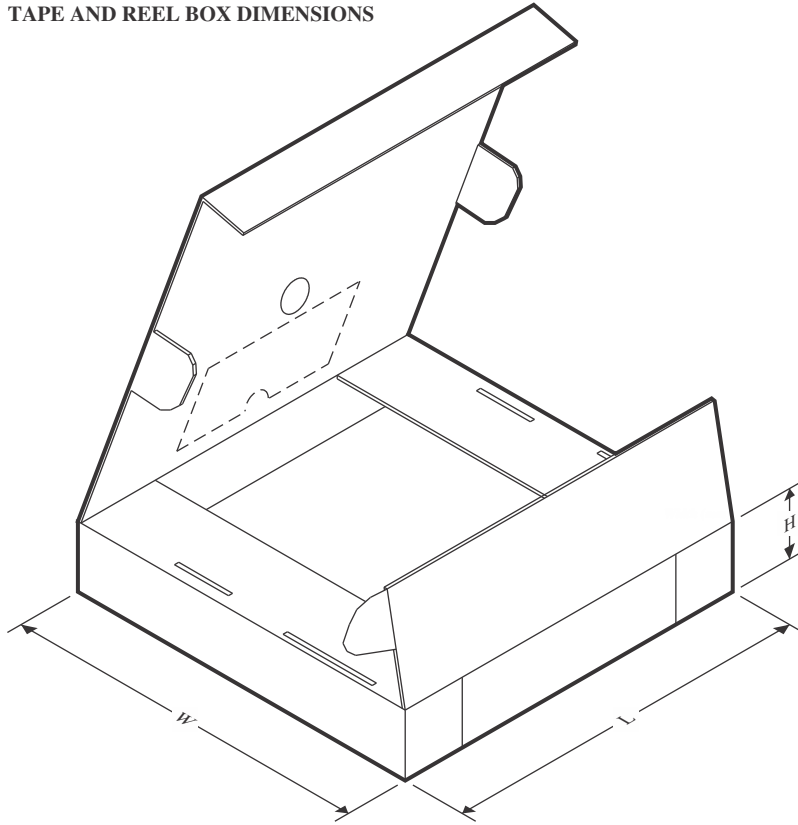
Device	Package Type	Package Drawing	Pins	SPQ	Reel Diameter (mm)	Reel Width W1 (mm)	A0 (mm)	B0 (mm)	K0 (mm)	P1 (mm)	W (mm)	Pin1 Quadrant
TPS650732TRSLRQ1	VQFN	RSL	48	2500	330.0	16.4	6.3	6.3	1.1	12.0	16.0	Q2

TAPE AND REEL BOX DIMENSIONS

*All dimensions are nominal

Device	Package Type	Package Drawing	Pins	SPQ	Length (mm)	Width (mm)	Height (mm)
TPS650732TRSLRQ1	VQFN	RSL	48	2500	356.0	356.0	35.0

MECHANICAL DATA

RSL (S-PVQFN-N48)

PLASTIC QUAD FLATPACK NO-LEAD

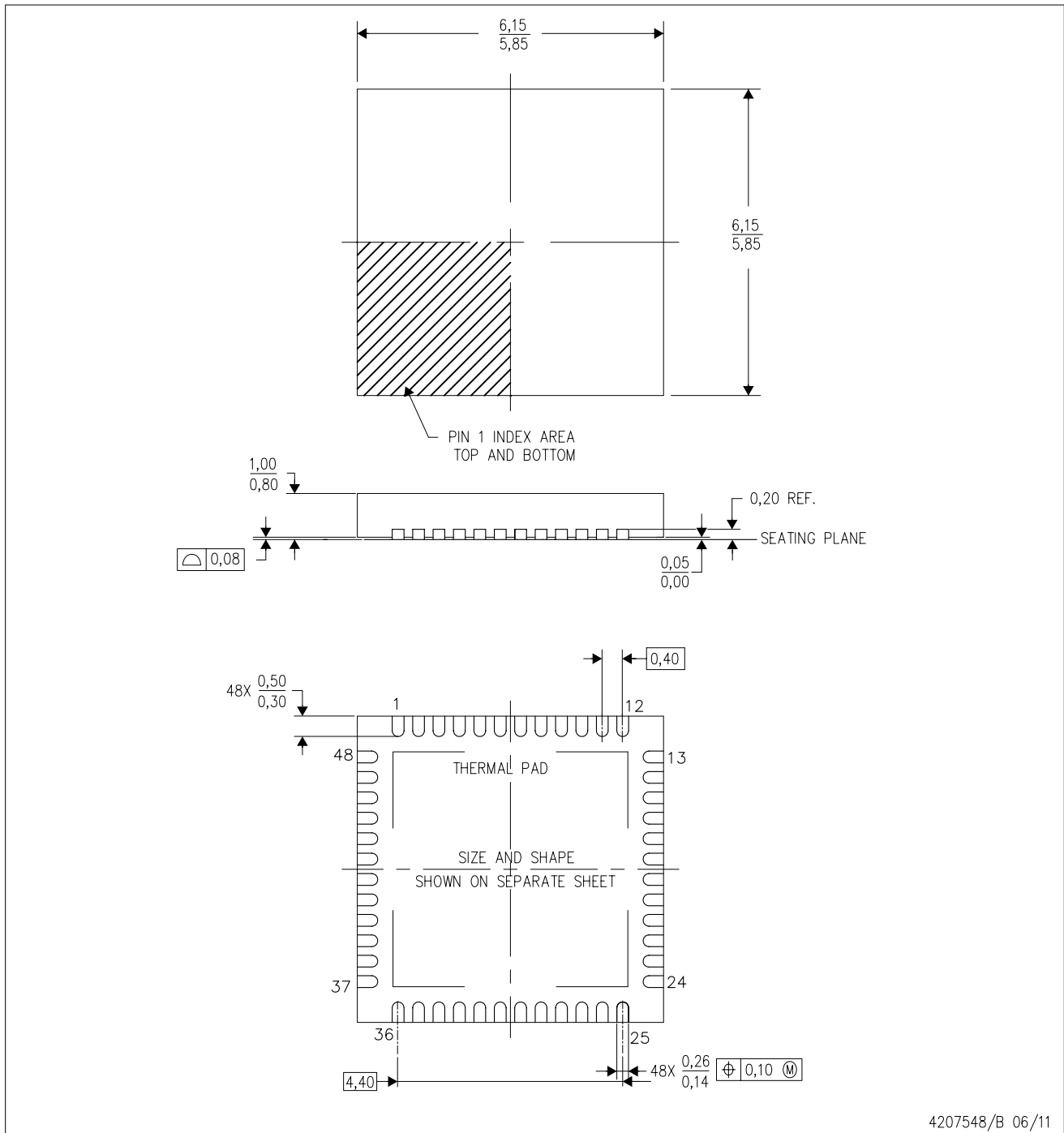

- NOTES:
- All linear dimensions are in millimeters. Dimensioning and tolerancing per ASME Y14.5M-1994.
 - This drawing is subject to change without notice.
 - Quad Flatpack, No-leads (QFN) package configuration.
 - The package thermal pad must be soldered to the board for thermal and mechanical performance.
 - See the additional figure in the Product Data Sheet for details regarding the exposed thermal pad features and dimensions.

THERMAL PAD MECHANICAL DATA

RSL (S-PVQFN-N48)

PLASTIC QUAD FLATPACK NO-LEAD

THERMAL INFORMATION

This package incorporates an exposed thermal pad that is designed to be attached directly to an external heatsink. The thermal pad must be soldered directly to the printed circuit board (PCB). After soldering, the PCB can be used as a heatsink. In addition, through the use of thermal vias, the thermal pad can be attached directly to the appropriate copper plane shown in the electrical schematic for the device, or alternatively, can be attached to a special heatsink structure designed into the PCB. This design optimizes the heat transfer from the integrated circuit (IC).

For information on the Quad Flatpack No-Lead (QFN) package and its advantages, refer to Application Report, QFN/SON PCB Attachment, Texas Instruments Literature No. SLUA271. This document is available at www.ti.com.

The exposed thermal pad dimensions for this package are shown in the following illustration.

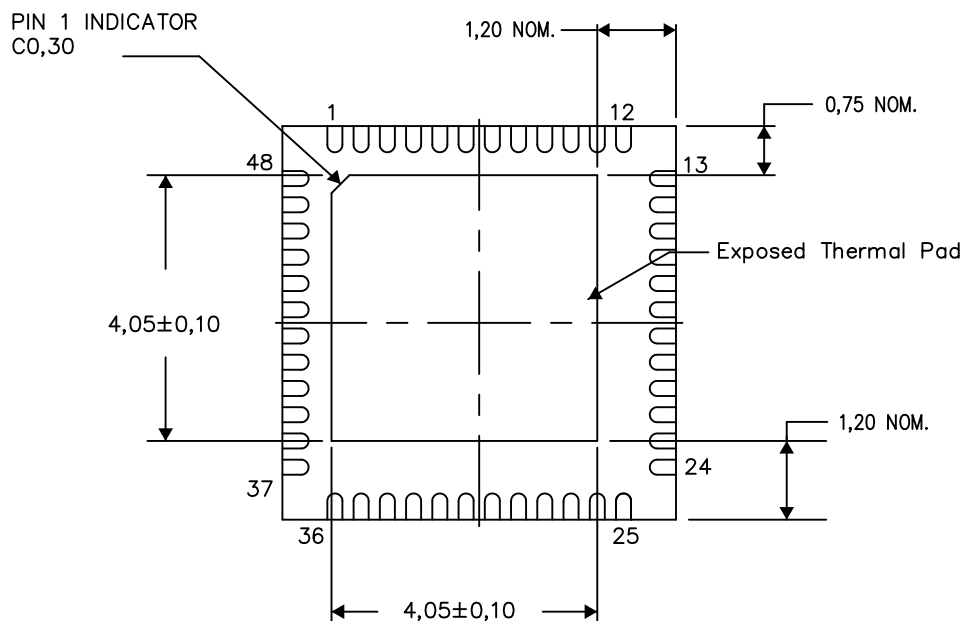

Bottom View

Exposed Thermal Pad Dimensions

4207841-4/P 03/13

NOTE: All linear dimensions are in millimeters

RSL (S-PVQFN-N48)

PLASTIC QUAD FLATPACK NO-LEAD

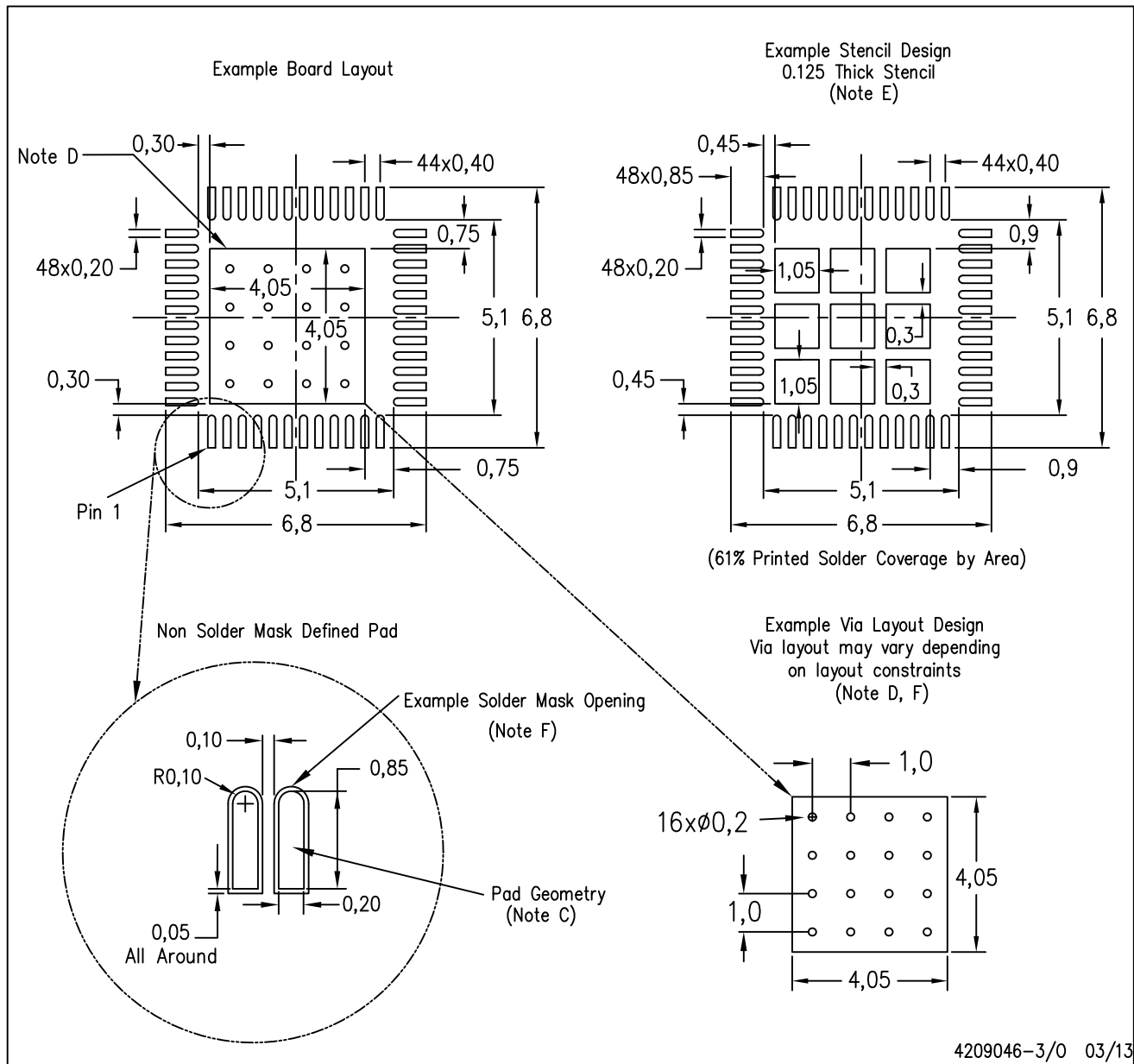

- NOTES:
- All linear dimensions are in millimeters.
 - This drawing is subject to change without notice.
 - Publication IPC-7351 is recommended for alternate designs.
 - This package is designed to be soldered to a thermal pad on the board. Refer to Application Note, QFN/SON PCB Attachment, Texas Instruments Literature No. SLUA271, and also the Product Data Sheets for specific thermal information, via requirements, and recommended board layout. These documents are available at www.ti.com <<http://www.ti.com>>.
 - Laser cutting apertures with trapezoidal walls and also rounding corners will offer better paste release. Customers should contact their board assembly site for stencil design recommendations. Refer to IPC 7525 for stencil design considerations.
 - Customers should contact their board fabrication site for recommended solder mask tolerances and via tenting recommendations for vias placed in the thermal pad.

IMPORTANT NOTICE AND DISCLAIMER

TI PROVIDES TECHNICAL AND RELIABILITY DATA (INCLUDING DATA SHEETS), DESIGN RESOURCES (INCLUDING REFERENCE DESIGNS), APPLICATION OR OTHER DESIGN ADVICE, WEB TOOLS, SAFETY INFORMATION, AND OTHER RESOURCES "AS IS" AND WITH ALL FAULTS, AND DISCLAIMS ALL WARRANTIES, EXPRESS AND IMPLIED, INCLUDING WITHOUT LIMITATION ANY IMPLIED WARRANTIES OF MERCHANTABILITY, FITNESS FOR A PARTICULAR PURPOSE OR NON-INFRINGEMENT OF THIRD PARTY INTELLECTUAL PROPERTY RIGHTS.

These resources are intended for skilled developers designing with TI products. You are solely responsible for (1) selecting the appropriate TI products for your application, (2) designing, validating and testing your application, and (3) ensuring your application meets applicable standards, and any other safety, security, regulatory or other requirements.

These resources are subject to change without notice. TI grants you permission to use these resources only for development of an application that uses the TI products described in the resource. Other reproduction and display of these resources is prohibited. No license is granted to any other TI intellectual property right or to any third party intellectual property right. TI disclaims responsibility for, and you will fully indemnify TI and its representatives against, any claims, damages, costs, losses, and liabilities arising out of your use of these resources.

TI's products are provided subject to [TI's Terms of Sale](#) or other applicable terms available either on ti.com or provided in conjunction with such TI products. TI's provision of these resources does not expand or otherwise alter TI's applicable warranties or warranty disclaimers for TI products.

TI objects to and rejects any additional or different terms you may have proposed.

Mailing Address: Texas Instruments, Post Office Box 655303, Dallas, Texas 75265
Copyright © 2022, Texas Instruments Incorporated