

REV.	DESCRIPTION	DATE
A	New Drawing	2008/11/12

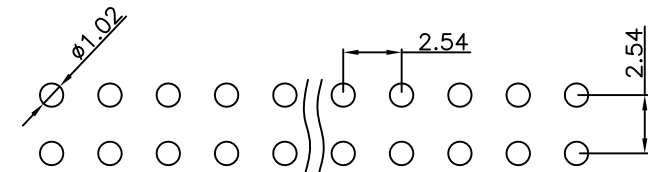

P.C.B LAYOUT

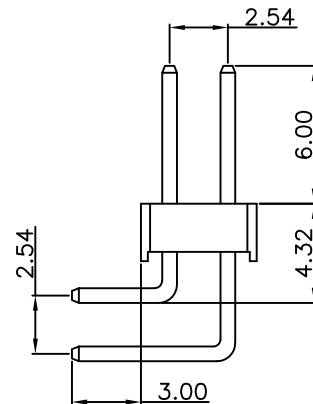
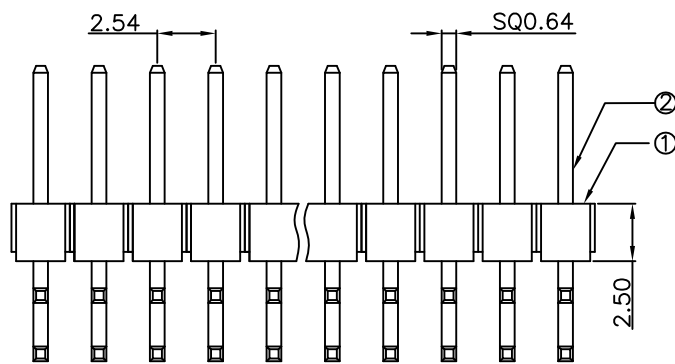
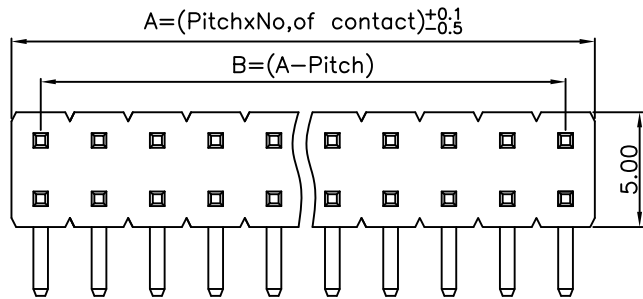
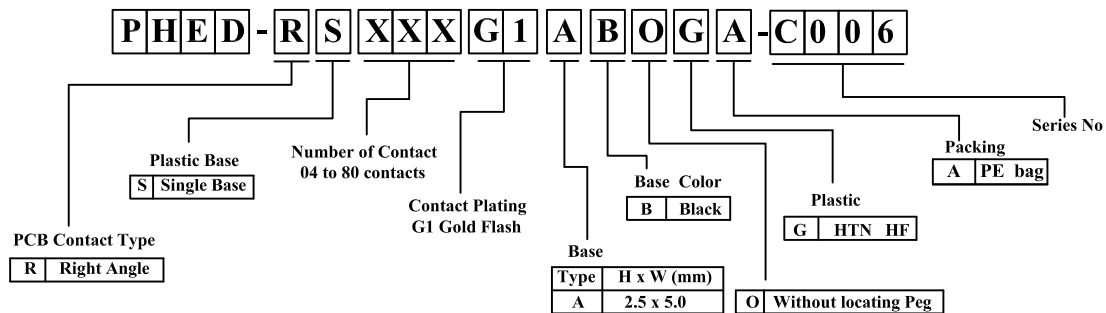

L=13.9/18.9mm

RoHS compliant

Superior Tech Co., Ltd.

General Tolerance		TITLE	Pitch 2.54x2.54mm Pin Header Dual Row,90°	
X.	± 0.5	DRAWN	DATE	NO.
.X	± 0.3	Yangqingming	11-12-08'	002
.XX	± 0.2	CHECK	DATE	PART NO.
.XXX	± 0.1	APPROVED	DATE	PHED-RSXXXG1ABOGA-C006
Angle	± 5°			CUSTOMER NO.
				DK

REV.	UNIT	SCALE
A	mm	1:1

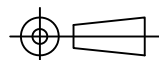

(Q2-R03-01A) ST-R05-07

REV.	DESCRIPTION	DATE
A	New Drawing	2022/05/26

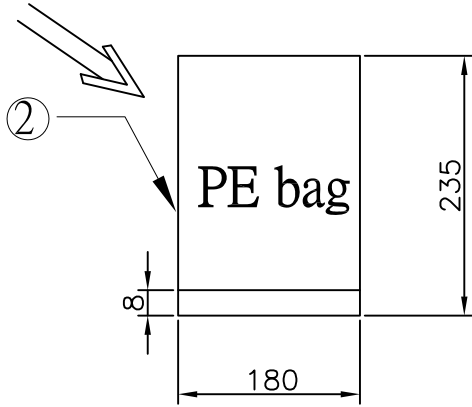
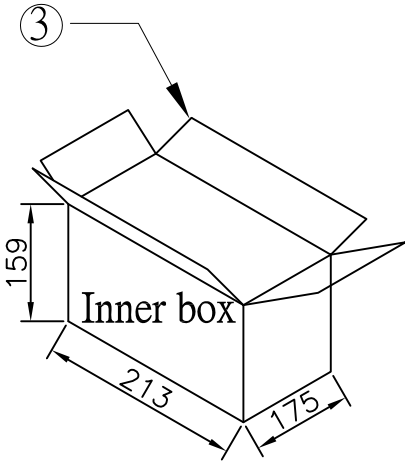
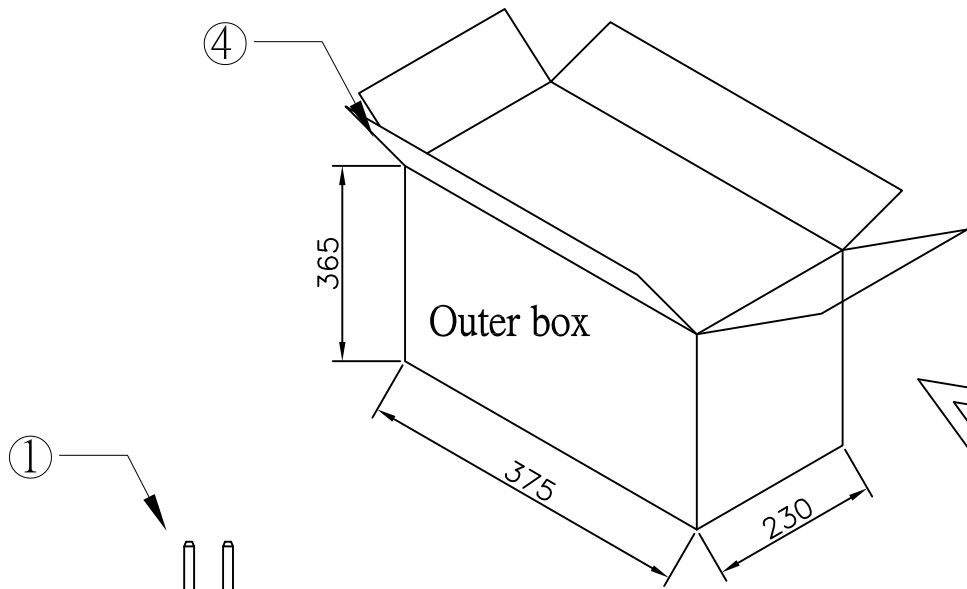

RoHS compliant

Note: The quantity is estimated, please refer to actual shipment.

④	Outer box	B-ZX-W-010-F001	1 PCS	10k PCS
③	Inner box	B-ZX-R-001-F001	4 PCS	2500 PCS
②	PE bag	B-PD-S-002-F001	20 PCS	500 PCS
①	Product	PH2.54 2*6PIN	—	—
Serial number	Name	Specifications	Dosage of cladding material	Quantity installed

Superior Tech Co., Ltd.

General Tolerance		TITLE PHED-RS012G1ABOGA-C006_Packing		
X. ± 0.5		DRAWN Tom	DATE 2022/05/26	NO. 002
.X ± 0.3			CHECK	DATE
.XX ± 0.2		APPROVED	DATE	CUSTOMER NO. DK
.XXX ± 0.1			DATE	
Angle	± 5°			

REV. A	UNIT mm	SCALE 1:10	
------------------	-------------------	----------------------	--

(Q2-R03-01A) ST-R05-07