

MoBL-USB™ TX2 USB 2.0 UTMI Transceiver

MoBL-USB™ TX2 Features

- UTMI-Compliant and USB 2.0 Certified for Device Operation
- Operates in Both USB 2.0 High Speed (HS), 480 Mbits/second, and Full Speed (FS), 12 Mbits/second
- Optimized for Seamless Interface with Intel® Monahans Applications Processors
- Tristate Mode Enables Sharing of UTMI Bus with other Devices
- Serial-to-Parallel and Parallel-to-Serial Conversions
- 8-bit Unidirectional, 8-bit Bidirectional, or 16-bit Bidirectional External Data Interface
- Synchronous Field and EOP Detection on Receive Packets
- Synchronous Field and EOP Generation on Transmit Packets
- Data and Clock Recovery from the USB Serial Stream
- Bit Stuffing and Unstuffing; Bit Stuff Error Detection
- Staging Register to Manage Data Rate Variation due to Bit Stuffing and Unstuffing
- 16-bit 30 MHz and 8-bit 60 MHz Parallel Interface
- Ability to Switch between FS and HS Terminations and Signaling
- Supports Detection of USB Reset, Suspend, and Resume
- Supports HS Identification and Detection as defined by the USB 2.0 Specification

- Supports Transmission of Resume Signaling
- 3.3V Operation
- Two Package Options: 56-pin QFN and 56-pin VFBGA
- All Required Terminations, Including 1.5 Kohm Pull Up on DPLUS, are Internal to Chip
- Supports USB 2.0 Test Modes

The Cypress MoBL-USB TX2 is a Universal Serial Bus (USB) specification revision 2.0 transceiver, serial and deserializer, to a parallel interface of either 16 bits at 30 MHz or eight bits at 60 MHz. The MoBL-USB TX2 provides a high speed physical layer interface that operates at the maximum allowable USB 2.0 bandwidth. This enables the system designer to keep the complex high speed analog USB components external to the digital ASIC. This decreases development time and associated risk. A standard USB 2.0-certified interface is provided and is compliant with Transceiver Macrocell Interface (UTMI) specification version 1.05 dated 3/29/2001.

This product is also optimized to seamlessly interface with Monahans -P & -L applications processors. It has been characterized by Intel and is recommended as the USB 2.0 UTMI transceiver of choice for its Monahans processors. It is also capable of tristating the UTMI bus, while suspended, to enable the bus to be shared with other devices.

Two packages are defined for the families: 56-pin QFN and 56-pin VFBGA.

The functional block diagram follows.

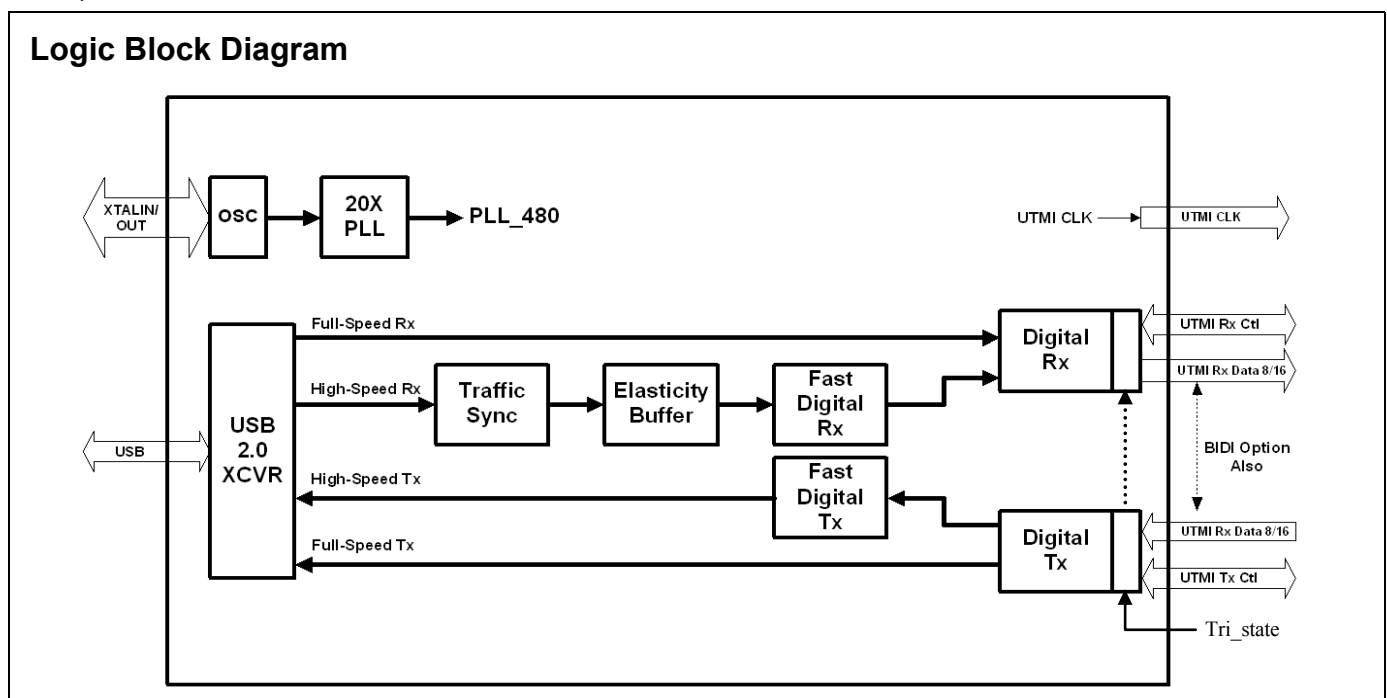

Applications

Mobile Applications

- Smart Phones
- PDA Phones
- Gaming Phones
- MP3 players
- Portable Media Players (PMP)
- GPS Tracking Devices

Consumer Applications

- Cameras
- Scanners
- DSL Modems
- Memory Card Readers

Non-Consumer Applications

- Networking
- Wireless LAN
- Home PNA

Functional Overview

The functionality of this chip is described in the following sections:

USB Signaling Speed

The MoBL-USB TX2 operates at two of the rates defined in the USB Specification 2.0, dated 4/27/2000.

- Full speed, with a signaling bit rate of 12 Mbps
- High speed, with a signaling bit rate of 480 Mbps

The MoBL-USB TX2 does not support the LS signaling rate of 1.5 Mbps.

Transceiver Clock Frequency

The MoBL-USB TX2 has an on-chip oscillator circuit that uses an external 24 MHz (± 100 ppm) crystal with the following characteristics:

- Parallel resonant
- Fundamental mode
- 500 μ W drive level
- 27 to 33 pF (5% tolerance) load capacitors

An on-chip phase-locked loop (PLL) multiplies the 24 MHz oscillator up to 30 or 60 MHz, as required by the transceiver parallel data bus. The default UTMI interface clock (CLK) frequency is determined by the DataBus16_8 pin.

Buses

The two packages enable a 8- or 16-bit bidirectional data bus for data transfers to a controlling unit.

Suspend and Tristate Modes

When the MoBL-USB TX2 is not in use, the processor reduces power consumption by putting it into Suspend mode using the Suspend pin.

While in Suspend mode, Tristate mode may be enabled, which tristates all outputs and I/Os, enabling the UTMI interface pins to be shared with other devices. This is valuable in mobile handset applications, where GPIOs are at a premium. The outputs and I/Os are tristated ~ 50 ns when Tristate mode is enabled, and are driven ~ 50 ns when Tri-state mode is disabled. All inputs must not be left floating while in Tristate mode.

When resuming after a suspend, the PLL stabilizes approximately 200 μ s after the suspend pin goes high.

Reset Pin

An input pin (Reset) resets the chip. This pin has hysteresis and is active HIGH according to the UTMI specification. The internal PLL stabilizes approximately 200 μ s after V_{CC} has reached 3.3V.

Line State

The Line State output pins LineState[1:0] are driven by combinational logic and may be toggling between the 'J' and the 'K' states. They are synchronized to the CLK signal for a valid signal. On the CLK edge, the state of these lines reflect the state of the USB data lines. Upon the clock edge the '0' bit of the LineState pins is the state of the DPLUS line and the '1' bit of LineState is the DMINUS line. When synchronized, the setup and hold timing of the LineState is identical to the parallel data bus.

Full Speed versus High Speed Select

The FS versus HS is done through the use of both XcvtSelect and the TermSelect input signals. The TermSelect signal enables the 1.5 Kohm pull up on to the DPLUS pin. When TermSelect is driven LOW, a SE0 is asserted on the USB providing the HS termination and generating the HS Idle state on the bus. The XcvtSelect signal is the control that selects either the FS transceivers or the HS transceivers. By setting this pin to a '0' the HS transceivers are selected and by setting this bit to a '1' the FS transceivers are selected.

Operational Modes

The operational modes are controlled by the OpMode signals. The OpMode signals are capable of inhibiting normal operation of the transceiver and evoking special test modes. These modes take effect immediately and take precedence over any pending data operations. The transmission data rate when in OpMode depends on the state of the XcvrSelect input.

OpMode[1:0]	Mode	Description
00	0	Normal operation
01	1	Non-driving
10	2	Disable Bit Stuffing and NRZI encoding
11	3	Reserved

Mode 0 enables the transceiver to operate with normal USB data decoding and encoding.

Mode 1 enables the transceiver logic to support a soft disconnect feature that tri-states both the HS and FS transmitters, and removes any termination from the USB, making it appear to an upstream port that the device is disconnected from the bus.

Mode 2 disables Bit Stuff and NRZI encoding logic so '1's loaded from the data bus becomes 'J's on the DPLUS/DMINUS lines and '0's become 'K's.

DPLUS/DMINUS Impedance Termination

The CY7C68000A does not require external resistors for USB data line impedance termination or an external pull up resistor on the DPLUS line. These resistors are incorporated into the part. They are factory trimmed to meet the requirements of USB 2.0. Incorporating these resistors also reduces the pin count on the part.

Pin Configurations

The following pages illustrate the individual pin diagrams that are available in the 56-pin QFN and 56-pin VFBGA packages. The packages offered use either an 8-bit (60 MHz) or 16-bit (30 MHz) bus interface.

Figure 1. CY7C68000A 56-pin QFN Pin Assignment

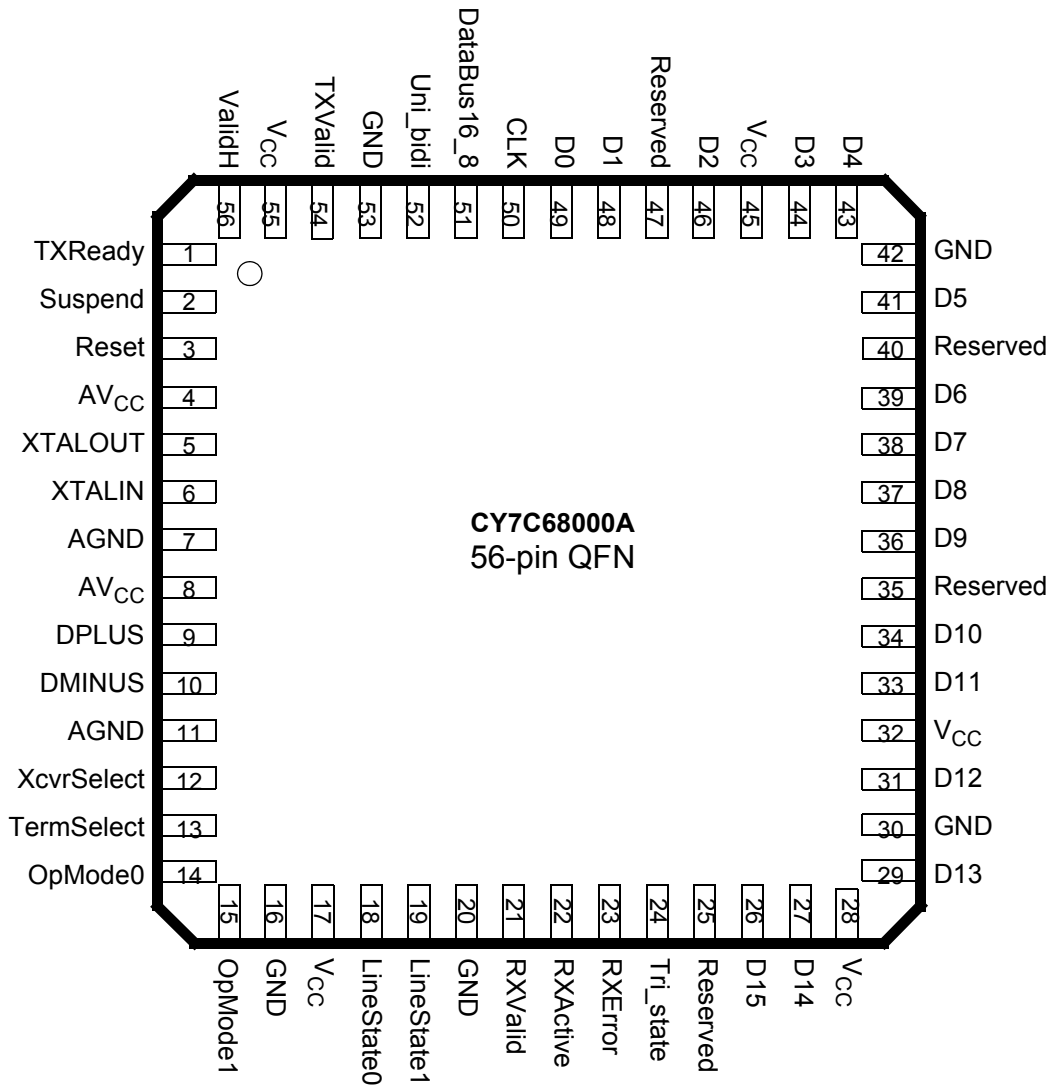
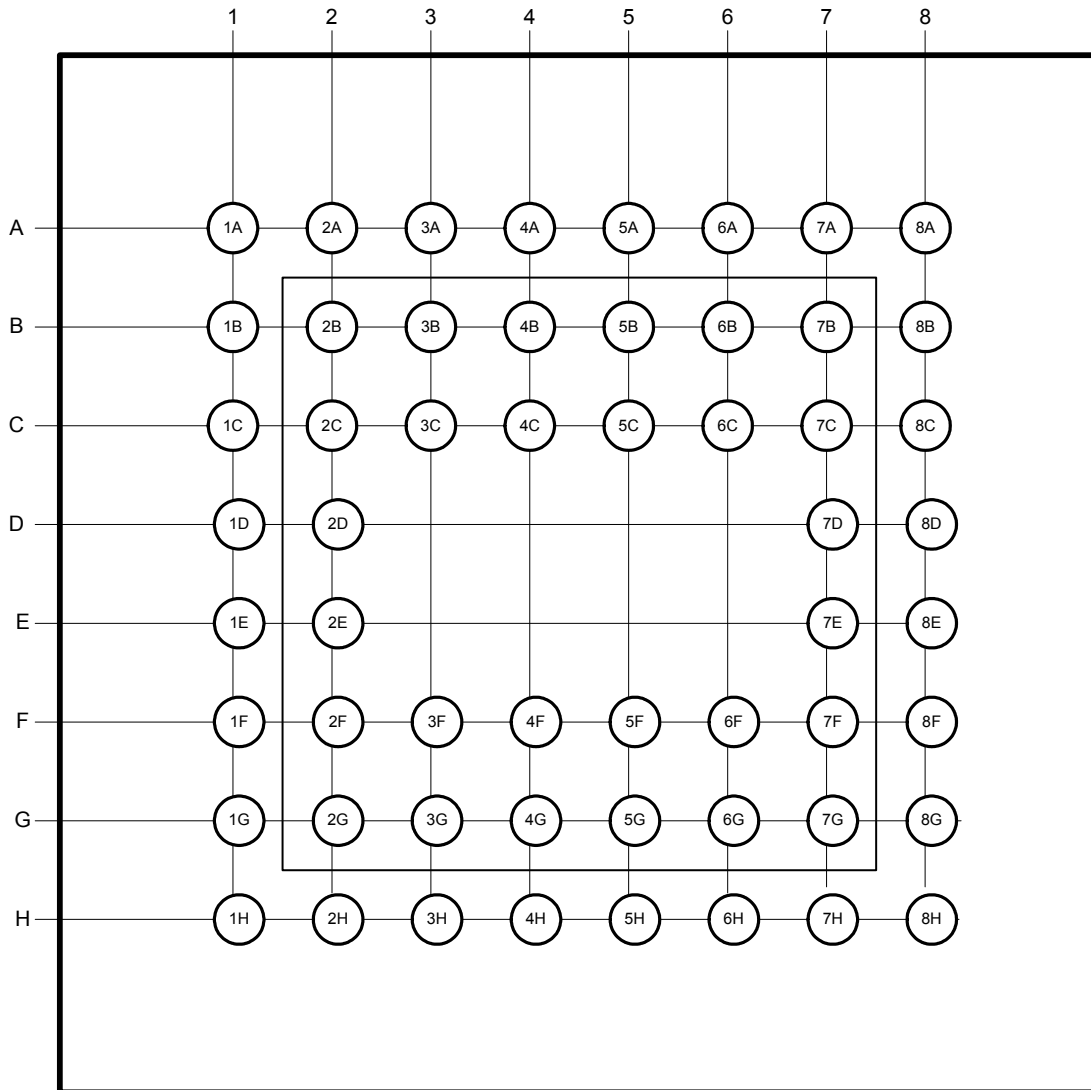

Figure 2. CY7C68000A 56-pin VFBGA Pin Assignment



Pin Descriptions

Table 1. Pin Descriptions

QFN	VFBGA	Name	Type	Default	Description ^[1]
4	H1	AVCC	Power	N/A	Analog V_{CC} This signal provides power to the analog section of the chip.
8	H5	AVCC	Power	N/A	Analog V_{CC} This signal provides power to the analog section of the chip.
7	H4	AGND	Power	N/A	Analog Ground Connect to ground with as short a path as possible.
11	H8	AGND	Power	N/A	Analog Ground Connect to ground with as short a path as possible.
9	H6	DPLUS	I/OZ	Z	USB DPLUS Signal Connect to the USB DPLUS signal.
10	H7	DMINUS	I/OZ	Z	USB DMINUS Signal Connect to the USB DMINUS signal.
49	G8	D0	I/O		Bidirectional Data Bus This bidirectional bus is used as the entire data bus in the 8-bit bidirectional mode or the least significant eight bits in the 16-bit mode. Under the 8-bit unidirectional mode, these bits are used as inputs for data, selected by the RxValid signal.
48	G7	D1	I/O		
46	G5	D2	I/O		
44	G3	D3	I/O		
43	G2	D4	I/O		
41	F8	D5	I/O		
39	F6	D6	I/O		
38	F5	D7	I/O		
37	F4	D8	I/O		
36	F3	D9	I/O		
34	F1	D10	I/O		Bidirectional Data Bus This bidirectional bus is used as the upper eight bits of the data bus when in the 16-bit mode, and not used when in the 8-bit bidirectional mode. Under the 8-bit unidirectional mode these bits are used as outputs for data, selected by the TxValid signal.
33	G4	D11	I/O		
31	E1	D12	I/O		
29	D8	D13	I/O		
27	G1	D14	I/O		
26	E2	D15	I/O		
50	A1	CLK	Output		Clock This output is used for clocking the receive and transmit parallel data on the D[15:0] bus.
3	B2	Reset	Input	N/A	Active HIGH Reset Resets the entire chip. This pin can be tied to V _{CC} through a 0.1-μF capacitor and to GND through a 100 K resistor for a 10-ms RC time constant.
12	B3	XcvrSelect	Input	N/A	Transceiver Select This signal selects between the Full Speed (FS) and the High Speed (HS) transceivers: 0: HS transceiver enabled 1: FS transceiver enabled
13	B4	TermSelect	Input	N/A	Termination Select This signal selects between the Full Speed (FS) and the High Speed (HS) terminations: 0: HS termination 1: FS termination
2	B1	Suspend	Input	N/A	Suspend Places the CY7C68000A in a mode that draws minimal power from supplies. Shuts down all blocks not necessary for Suspend/Resume operations. While suspended, TermSelect must always be in FS mode to ensure that the 1.5 Kohm pull up on DPLUS remains powered. 0: CY7C68000A circuitry drawing suspend current 1: CY7C68000A circuitry drawing normal current

Note

- Unused inputs should not be left floating. Tie either HIGH or LOW as appropriate. Outputs that are three-statable should only be pulled up or down to ensure signals at power-up and in standby.

Table 1. Pin Descriptions (continued)

QFN	VFBGA	Name	Type	Default	Description ^[1] (continued)
24	B8	Tri_state	Input		Tri-state Mode Enable Places the CY7C68000A into Tri-state mode which tri-states all outputs and IOs. Tri-state Mode can only be enabled while suspended. 0: Disables Tri-state Mode 1: Enables Tri-state Mode
19	C2	LineState1	Output		Line State These signals reflect the current state of the single-ended receivers. They are combinatorial until a “usable” CLK is available then they are synchronized to CLK. They directly reflect the current state of the DPLUS (LineState0) and DMINUS (LineState1). D– D+ Description 0 0 0: SE0 0 1 1: ‘J’ State 1 0 2: ‘K’ State 1 1 3: SE1
18	C1	LineState0	Output		Line State These signals reflect the current state of the single-ended receivers. They are combinatorial until a ‘usable’ CLK is available then they are synchronized to CLK. They directly reflect the current state of the DPLUS (LineState0) and DMINUS (LineState1). D– D+ Description 00–0: SE0 01–1: ‘J’ State 10–2: ‘K’ State 11–3: SE1
15	B6	OpMode1	Input		Operational Mode These signals select among various operational modes. 10 Description 00–0: Normal Operation 01–1: Non-driving 10–2: Disable Bit Stuffing and NRZI encoding 11–3: Reserved
14	B5	OpMode0	Input		Operational Mode These signals select among various operational modes. 10 Description 00–0: Normal Operation 01–1: Non-driving 10–2: Disable Bit Stuffing and NRZI encoding 11–3: Reserved
54	A5	TXValid	Input		Transmit Valid This signal indicates that the data bus is valid. The assertion of Transmit Valid initiates SYNC on the USB. The negation of Transmit Valid initiates EOP on the USB. The start of SYNC must be initiated on the USB no less than one or no more that two CLKs after the assertion of TXValid. In HS (XcvrSelect = 0) mode, the SYNC pattern must be asserted on the USB between 8- and 16-bit times after the assertion of TXValid is detected by the Transmit State Machine. In FS (Xcvr = 1), the SYNC pattern must be asserted on the USB no less than one or more than two CLKs after the assertion of TXValid is detected by the Transmit State Machine.
1	A8	TXReady	Output		Transmit Data Ready If TXValid is asserted, the SIE must always have data available for clocking in to the TX Holding Register on the rising edge of CLK. If TXValid is TRUE and TXReady is asserted at the rising edge of CLK, the CY7C68000A loads the data on the data bus into the TX Holding Register on the next rising edge of CLK. At that time, the SIE should immediately present the data for the next transfer on the data bus.

Table 1. Pin Descriptions (continued)

QFN	VFBGA	Name	Type	Default	Description ^[1] (continued)
21	A4	RXValid	Output		Receive Data Valid This signal indicates that the DataOut bus has valid data. The Receive Data Holding Register is full and ready to be unloaded. The SIE is expected to latch the DataOut bus on the clock edge.
22	B7	RXActive	Output		Receive Active This signal indicates that the receive state machine has detected SYNC and is active. RXActive is negated after a bit stuff error or an EOP is detected.
23	A6	RXError	Output		Receive Error 0 Indicates no error. 1 Indicates that a receive error has been detected.
56	A7	ValidH	I/O		ValidH This signal indicates that the high-order eight bits of a 16-bit data word presented on the Data bus are valid. When DataBus16_8 = 1 and TXValid = 0, ValidH is an output, indicating that the high-order receive data byte on the Data bus is valid. When DataBus16_8 = 1 and TXValid = 1, ValidH is an input and indicates that the high-order transmit data byte, presented on the Data bus by the transceiver, is valid. When DataBus16_8 = 0, ValidH is undefined. The status of the receive low-order data byte is determined by RXValid and are present on D0–D7.
51	A2	DataBus16_8	Input		Data Bus 16_8 This signal selects between 8- and 16-bit data transfers. 1–16-bit data path operation enabled. CLK = 30 MHz. 0–8-bit data path operation enabled. When Uni_Bidi = 0, D[8:15] are undefined. When Uni_Bidi = 1, D[0:7] are valid on TxValid and D[8:15] are valid on RxValid. CLK = 60 MHz Note: DataBus16_8 is static after Power-on Reset (POR) and is only sampled at the end of Reset.
6	H3	XTALIN	Input	N/A	Crystal Input Connect this signal to a 24 MHz parallel-resonant, fundamental mode crystal and 30 pF capacitor to GND. It is also correct to drive XTALIN with an external 24 MHz square wave derived from another clock source.
5	H2	XTALOUT	Output	N/A	Crystal Output Connect this signal to a 24 MHz parallel-resonant, fundamental mode crystal and 30 pF (nominal) capacitor to GND. If an external clock is used to drive XTALIN, leave this pin open.
52	A3	Uni_Bidi	Input		Driving this pin HIGH enables the unidirectional mode when the 8-bit interface is selected. Uni_Bidi is static after power-on reset (POR).
55	C6	V _{CC}	Power		V _{CC} . Connect to 3.3V power source.
17	C7	V _{CC}	Power	N/A	V _{CC} . Connect to 3.3V power source.
28	D7	V _{CC}	Power	N/A	V _{CC} . Connect to 3.3V power source.
32	E7	V _{CC}	Power	N/A	V _{CC} . Connect to 3.3V power source.
45	E8	V _{CC}	Power	N/A	V _{CC} . Connect to 3.3V power source.
53	C4	GND	Ground	N/A	Ground.
16	C5	GND	Ground	N/A	Ground.
20	C3	GND	Ground	N/A	Ground.
30	D1	GND	Ground	N/A	Ground.
42	D2	GND	Ground	N/A	Ground.
47	G6	Reserved	INPUT		Connect pin to Ground.
40	F7	Reserved	INPUT		Connect pin to Ground.
35	F2	Reserved	INPUT		Connect pin to Ground.
25	C8	Reserved	INPUT		Connect pin to Ground.

Absolute Maximum Ratings

Storage Temperature -65°C to +150°C
 Ambient Temperature with Power Supplied 0°C to +70°C
 Supply Voltage to Ground Potential -0.5V to +4.0V
 DC Input Voltage to Any Input Pin 5.25 V
 DC Voltage Applied to Outputs
 in High-Z State -0.5V to $V_{CC} + 0.5V$
 Power Dissipation 630 mW
 Static Discharge Voltage > 2000V

Max Output Current, per IO pin 4 mA
 Max Output Current, all 21-IO pins 84 mA

Operating Conditions

T_A (Ambient Temperature Under Bias) 0°C to +70°C
 Supply Voltage +3.0V to +3.6V
 Ground Voltage 0V
 F_{OSC} (Oscillator or Crystal Frequency) ... 24 MHz \pm 100 ppm
 Parallel Resonant

DC Characteristics

Table 2. DC Characteristics

Parameter	Description	Conditions	Min	Typ	Max	Unit
V_{CC}	Supply Voltage		3.0	3.3	3.6	V
V_{IH}	Input High Voltage		2		5.25	V
V_{IL}	Input Low Voltage		-0.5		0.8	V
I_I	Input Leakage Current	$0 < V_{IN} < V_{CC}$			± 10	μA
V_{OH}	Output Voltage High	$I_{OUT} = 4 \text{ mA}$	2.4			V
V_{OL}	Output Low Voltage	$I_{OUT} = -4 \text{ mA}$			0.4	V
I_{OH}	Output Current High				4	mA
I_{OL}	Output Current Low				4	mA
C_{IN}	Input Pin Capacitance	Except DPLUS/DMINUS/CLK			10	pF
		DPLUS/DMINUS/CLK			15	pF
C_{LOAD}	Maximum Output Capacitance	Output pins			30	pF
I_{SUSP}	Suspend Current	Connected ^[2]		228	273	μA
		Disconnected ^[2]		8	35	μA
I_{CC}	Supply Current HS Mode	Normal operation OPMOD[1:0] = 00			175	mA
I_{CC}	Supply Current FS Mode	Normal operation OPMOD[1:0] = 00			90	mA
t_{RESET}	Minimum Reset time		1.9			ms

Note

2. Connected to the USB includes 1.5 Kohm internal pull up. Disconnected has the 1.5 Kohm internal pull up excluded.

AC Electrical Characteristics

USB 2.0 Transceiver

USB 2.0-compliant in FS and HS modes.

Timing Diagram

HS/FS Interface Timing - 60 MHz

Figure 3. 60 MHz Interface Timing Constraints

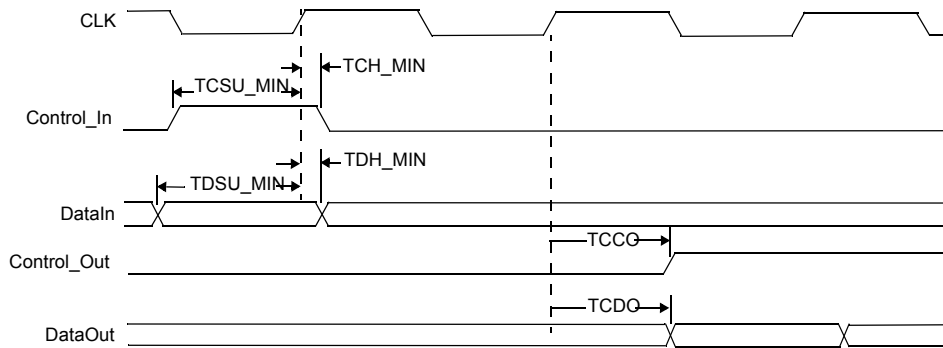

Table 3. 60 MHz Interface Timing Constraints Parameters

Parameter	Description	Min	Typ	Max	Unit	Notes
T_{CSU_MIN}	Minimum setup time for TXValid	4			ns	
T_{CH_MIN}	Minimum hold time for TXValid	1			ns	
T_{DSU_MIN}	Minimum setup time for Data (transmit direction)	4			ns	
T_{DH_MIN}	Minimum hold time for Data (transmit direction)	1			ns	
T_{CCO}	Clock to Control out time for TXReady, RXValid, RXActive and RXError	1		8	ns	
T_{CDO}	Clock to Data out time (Receive direction)	1		8	ns	

HS/FS Interface Timing - 30 MHz

Figure 4. 30 MHz Timing Interface Timing Constraints

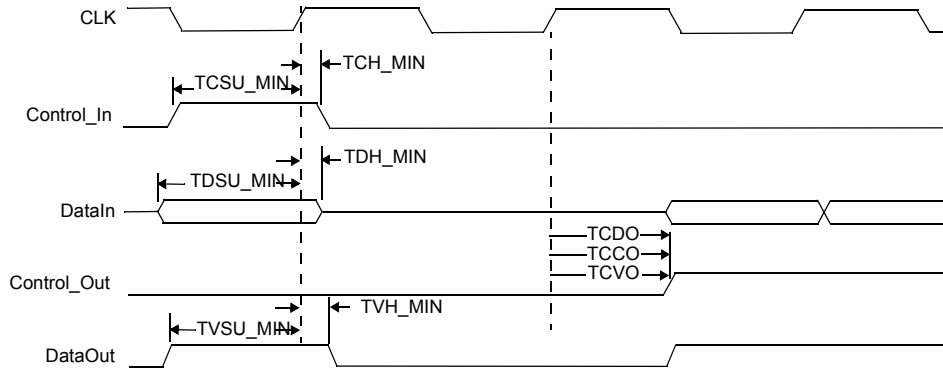

Table 4. 30 MHz Timing Interface Timing Constraints Parameters

Parameter	Description	Min	Typ	Max	Unit	Notes
T _{CSU_MIN}	Minimum setup time for TXValid	16			ns	
T _{CH_MIN}	Minimum hold time for TXValid	1			ns	
T _{DSU_MIN}	Minimum setup time for Data (Transmit direction)	16			ns	
T _{DH_MIN}	Minimum hold time for Data (Transmit direction)	1			ns	
T _{CCO}	Clock to Control Out time for TXReady, RXValid, RXActive and RXError	1		20	ns	
T _{CDO}	Clock to Data out time (Receive direction)	1		20	ns	
T _{VSU_MIN}	Minimum setup time for ValidH (transmit Direction)	16			ns	
T _{VH_MIN}	Minimum hold time for ValidH (Transmit direction)	1			ns	
T _{CVO}	Clock to ValidH out time (Receive direction)	1		20	ns	

Figure 5. Tristate Mode Timing Constraints

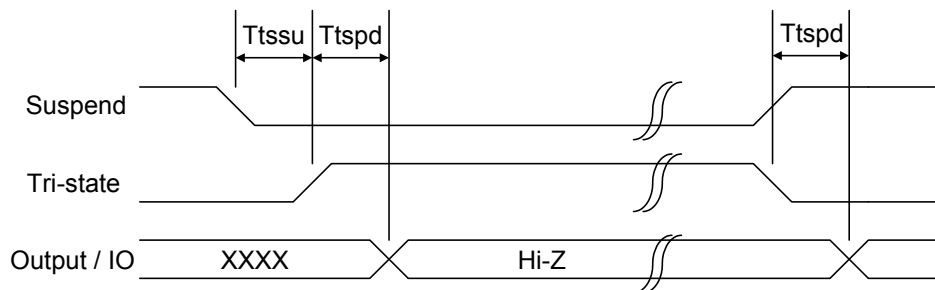

Table 5. Tristate Mode Timing Constraints Parameters

Parameter	Description	Min	Typ	Max	Unit	Notes
T _{tssu}	Minimum setup time for Tristate	0			ns	
T _{tspd}	Propagation Delay for Tristate mode			50	ns	

Ordering Information

Ordering Code	Package Type
CY7C68000A-56LFXC	56 QFN
CY7C68000A-56BAXC	56 VFBGA
CY7C68000A-56LTXC	56 QFN
CY7C68000A-56LTXCT	56 QFN
CY3683	MoBL-USB TX2 Development Board

Package Diagrams

The MoBL-USB TX2 is available in two packages:

- 56-pin QFN
- 56-pin VFBGA

Figure 6. 56-Pin Quad Flatpack No Lead Package 8 x 8 mm (Sawn Version)

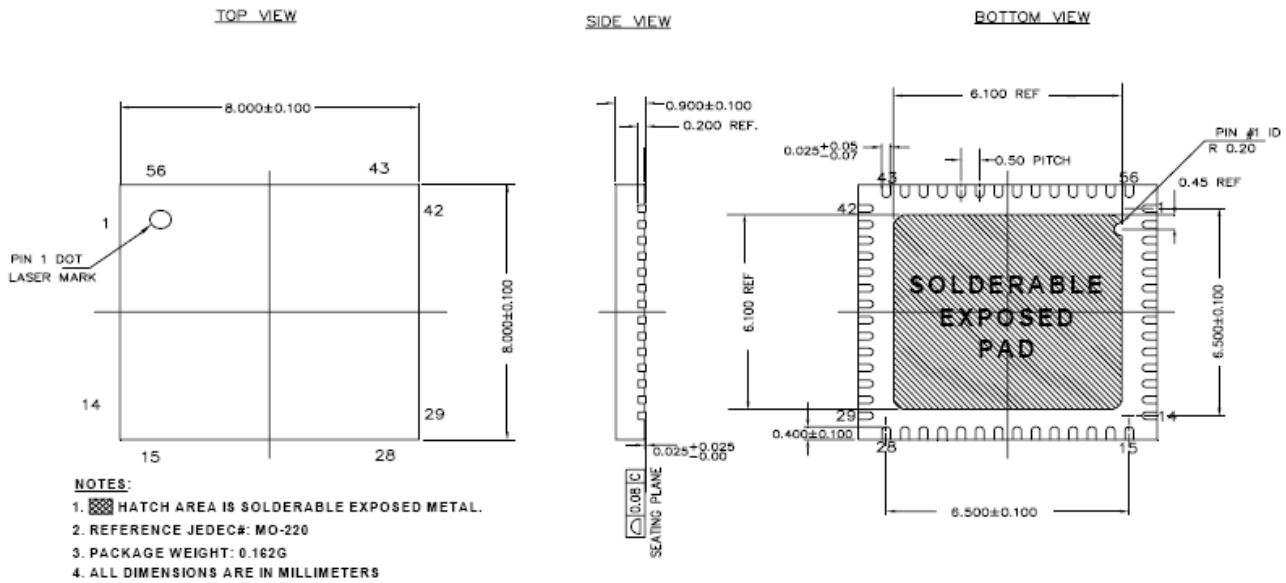

51-85187 °C

Package Diagrams (continued)

Figure 7. 56 VFBGA (5 x 5 x 1.0 mm) 0.50 Pitch, 0.30 Ball BZ56

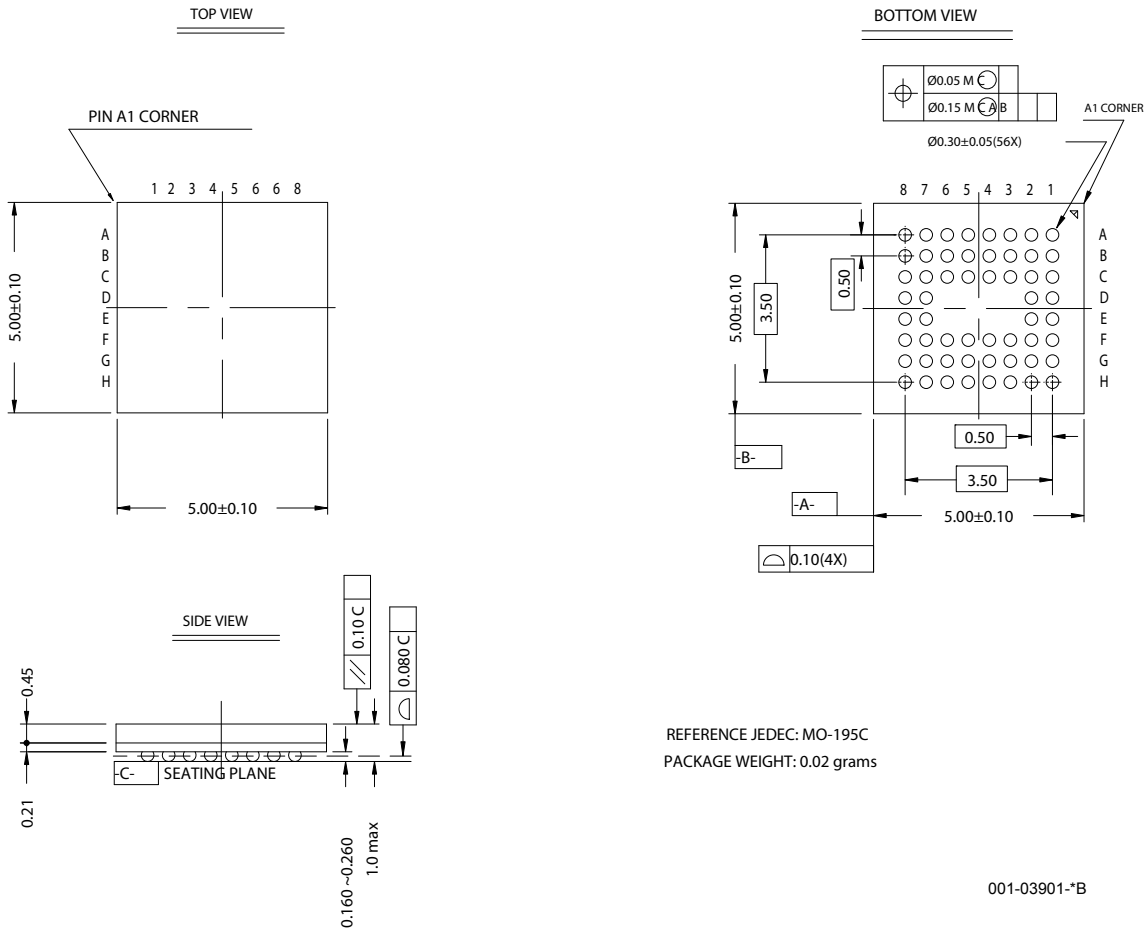

PCB Layout Recommendations

Follow these recommendations to ensure reliable, high performance operation^[3].

- A four-layer impedance controlled board is required to maintain signal quality
- Specify impedance targets (ask your board vendor what they can achieve)
- To control impedance, maintain trace widths and trace spacing to within written specifications
- Minimize stubs to minimize reflected signals

- Connections between the USB connector shell and signal ground must be done near the USB connector
- Bypass and flyback capacitors on VBus, near the connector, are recommended
- Keep DPLUS and DMINUS trace lengths within 2 mm of each other in length, with preferred length of 20 to 30 mm
- Maintain a solid ground plane under the DPLUS and DMINUS traces. Do not split the plane under these traces
- Do not place vias on the DPLUS or DMINUS trace routing
- Isolate the DPLUS and DMINUS traces from all other signal traces by no less than 10 mm

Note

3. Source for recommendations: EZ-USB FX2™ PCB Design Recommendations, http://www.cypress.com/cfuploads/support/app_notes/FX2_PCB.pdf
High-Speed USB Platform Design Guidelines, http://www.usb.org/developers/docs/hs_usb_pdg_r1_0.pdf.

Quad Flat Package No Leads (QFN) Package Design Notes

Electrical contact of the part to the Printed Circuit Board (PCB) is made by soldering the leads on the bottom surface of the package to the PCB. Hence, special attention is required to the heat transfer area below the package to provide a good thermal bond to the circuit board. A Copper (Cu) fill is to be designed into the PCB as a thermal pad under the package. Heat is transferred from the MoBL-USB TX2 through the device’s metal paddle on the package bottom. From here, heat is conducted to the PCB at the thermal pad. It is then conducted from the thermal pad to the PCB inner ground plane by an array of via. A via is a plated through-hole in the PCB with a finished diameter of 13 mil. The QFN’s metal die paddle must be soldered to the PCB’s thermal pad. Solder mask is placed on the board top, over each via, to resist solder flow into the via. The mask on the top side also minimizes outgassing during the solder reflow process.

For further information on this package design, refer to the application note “Surface Mount Assembly of AMKOR’s MicroLead-Frame (MLF) Technology.” Download this application note from AMKOR’s website, by following this link: http://www.amkor.com/products/notes_papers/MLFAppNote.pdf. The application note provides detailed information on board mounting guidelines, soldering flow, and rework process.

Figure 8 displays a cross-sectional area under the package. The cross section is of only one via. The solder paste template needs to be designed to enable at least 50 percent solder coverage. The thickness of the solder paste template should be 5 mil. It is recommended that ‘No Clean’, type 3 solder paste be used for mounting the part. Nitrogen purge is recommended during reflow.

Figure 9 is a plot of the solder mask pattern image of the assembly (darker areas indicate solder).

Figure 8. Cross section of the Area Underneath the QFN Package

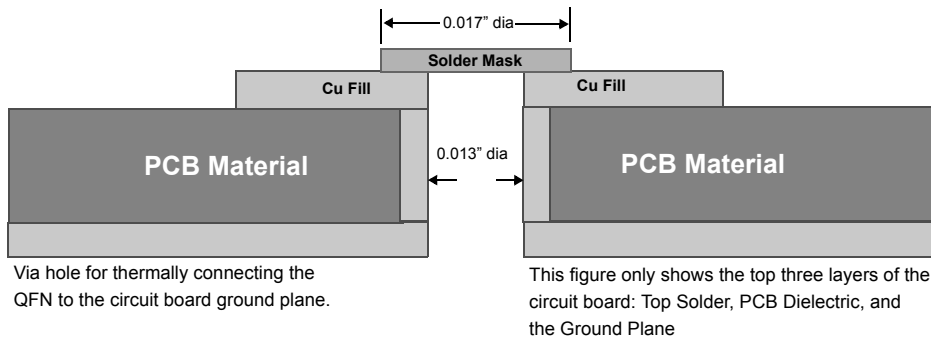
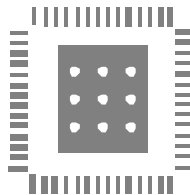

Figure 9. Plot of the Solder Mask (White Area)



Document History Page

Document Title: CY7C68000A MoBL-USB™ TX2 USB 2.0 UTMI Transceiver Document Number: 38-08052				
REV.	ECN NO.	Orig. of Change	Submission Date	Description of Change
**	285592	KKU	See ECN	New data sheet
*A	427959	TEH	See ECN	Addition of VFBGA Package information and Pinout, Removal of SSOP Package. Edited text and moved figure titles to the top per new template
*B	470121	TEH	See ECN	Change from preliminary to final data sheet. Grammatical and formatting changes
*C	476107	TEH	See ECN	This data sheet needs to be posted to the web site under NDA
*D	491668	TEH	See ECN	Addition of Tri-state Mode
*E	498415	TEH	See ECN	Update power consumption numbers
*F	567869	TEH	See ECN	Remove NDA requirement
*G	2587010	KKU/PYRS	10/13/08	Updated Pin 6 description on Page 8 Updated template
*H	2710327	DPT	05/22/2009	Updated Ordering Information for CY7C68000A-56LTXC and CY7C68000A-56LTXCT parts

Sales, Solutions, and Legal Information

Worldwide Sales and Design Support

Cypress maintains a worldwide network of offices, solution centers, manufacturer’s representatives, and distributors. To find the office closest to you, visit us at cypress.com/sales.

Products

PSoC	psoc.cypress.com
Clocks & Buffers	clocks.cypress.com
Wireless	wireless.cypress.com
Memories	memory.cypress.com
Image Sensors	image.cypress.com

PSoC Solutions

General	psoc.cypress.com/solutions
Low Power/Low Voltage	psoc.cypress.com/low-power
Precision Analog	psoc.cypress.com/precision-analog
LCD Drive	psoc.cypress.com/lcd-drive
CAN 2.0b	psoc.cypress.com/can
USB	psoc.cypress.com/usb

© Cypress Semiconductor Corporation, 2004-2009. The information contained herein is subject to change without notice. Cypress Semiconductor Corporation assumes no responsibility for the use of any circuitry other than circuitry embodied in a Cypress product. Nor does it convey or imply any license under patent or other rights. Cypress products are not warranted nor intended to be used for medical, life support, life saving, critical control or safety applications, unless pursuant to an express written agreement with Cypress. Furthermore, Cypress does not authorize its products for use as critical components in life-support systems where a malfunction or failure may reasonably be expected to result in significant injury to the user. The inclusion of Cypress products in life-support systems application implies that the manufacturer assumes all risk of such use and in doing so indemnifies Cypress against all charges.

Any Source Code (software and/or firmware) is owned by Cypress Semiconductor Corporation (Cypress) and is protected by and subject to worldwide patent protection (United States and foreign), United States copyright laws and international treaty provisions. Cypress hereby grants to licensee a personal, non-exclusive, non-transferable license to copy, use, modify, create derivative works of, and compile the Cypress Source Code and derivative works for the sole purpose of creating custom software and/or firmware in support of licensee product to be used only in conjunction with a Cypress integrated circuit as specified in the applicable agreement. Any reproduction, modification, translation, compilation, or representation of this Source Code except as specified above is prohibited without the express written permission of Cypress.

Disclaimer: CYPRESS MAKES NO WARRANTY OF ANY KIND, EXPRESS OR IMPLIED, WITH REGARD TO THIS MATERIAL, INCLUDING, BUT NOT LIMITED TO, THE IMPLIED WARRANTIES OF MERCHANTABILITY AND FITNESS FOR A PARTICULAR PURPOSE. Cypress reserves the right to make changes without further notice to the materials described herein. Cypress does not assume any liability arising out of the application or use of any product or circuit described herein. Cypress does not authorize its products for use as critical components in life-support systems where a malfunction or failure may reasonably be expected to result in significant injury to the user. The inclusion of Cypress’ product in a life-support systems application implies that the manufacturer assumes all risk of such use and in doing so indemnifies Cypress against all charges.

Use may be limited by and subject to the applicable Cypress software license agreement.