

10 9 8 7 6 5 4 3 2 106160

| ADAPTER P/N | SPRING LEVER COLOR | MATERIAL OF SLEEVE | SHELL COLOR |
|--------------|--------------------|---------------------|-------------|
| 106160-0000 | BLUE | PHOSPHOR BRONZE Zr, | BLUE |
| 106161-0000 | | LOW COST | |
| 106160-0100* | | | |
| 106160-1000 | BLACK | PHOSPHOR BRONZE Zr | RED |
| 106161-1000 | | PHOSPHOR BRONZE Zr | BLACK |
| 106160-2000 | | | |
| 106161-2000 | | | |
| 106160-3000 | BLUE | PHOSPHOR BRONZE Zr, | GREEN |
| 106160-3100* | | LOW COST | |
| 106161-3000 | | | |
| 106161-3100* | | | |
| 106160-5000 | BLACK | PHOSPHOR BRONZE Zr | BEIGE |
| 106161-5000 | | | |

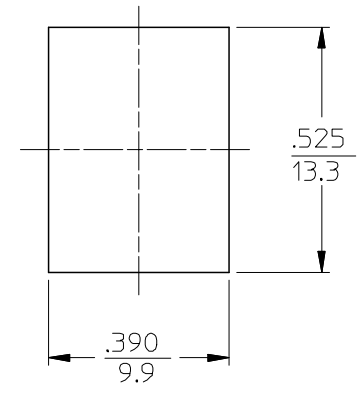
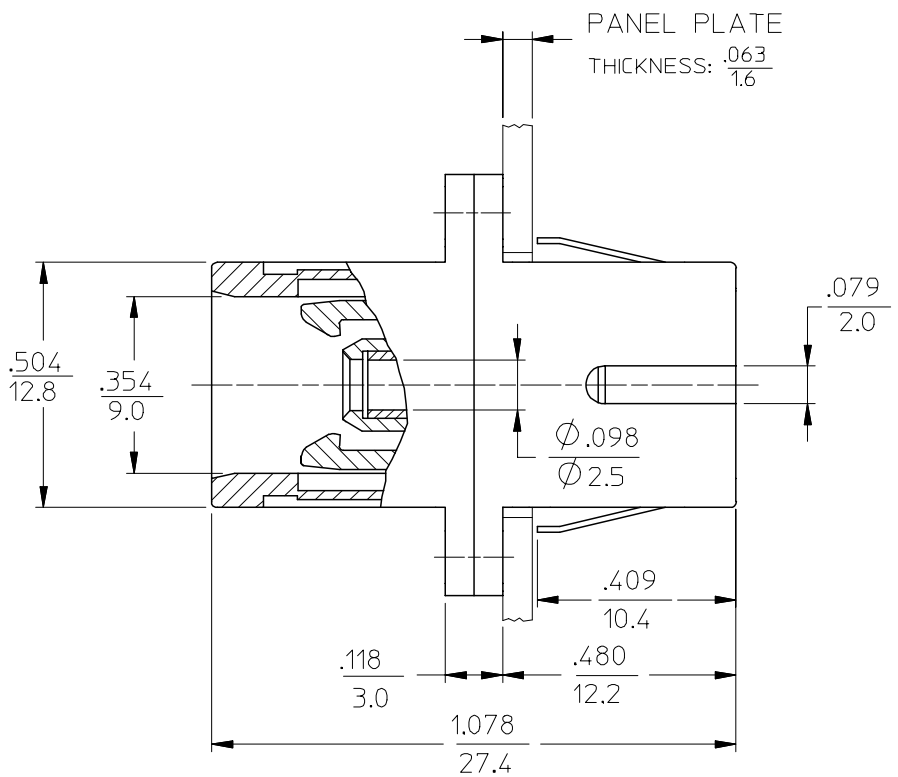
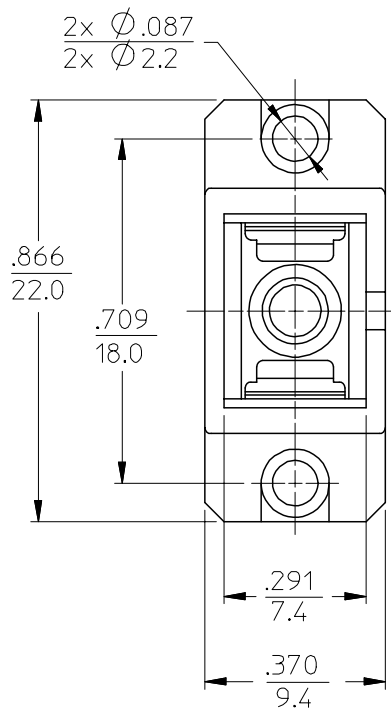

RECOMMENDED MOUNTING HOLE

- NOTES:
- DUST CAPS ARE NOT SHOWN BUT INCLUDED.
 - *2. P/Ns 106160-3100, 106161-0100 AND 106161-3100 ARE BULK PACKED IN QUANTITIES OF 100 pcs.
 - ALL MATERIALS USED IN ADAPTER MEET UL94 V-0.

| ENTER DESCRIPTION EC NO: MF2007-0737 DRWN:KPEVNER CHKD: APPR:IGUMIN 2007/05/30 2007/05/30 2007/05/30 | QUALITY SYMBOLS | GENERAL TOLERANCES (UNLESS SPECIFIED) | DIMENSION STYLE | SCALE | DESIGN UNITS | THIRD ANGLE PROJECTION | | | | | | | | | | | | | | | |
|---------------------------------------------------------------------------------------------------------------------------|--------------------------|---------------------------------------------------------------------------------------------------------------------------------------------------------------------------------------------------------------------------------------------------------------------------------------------------------------------------------------------------------------------------------------------|------------------------------------------------------------------------------------------|-----------------------------|-----------------------------------------|------------------------|--------|---------|----------|--------|---------|----------|--------|---------|---------|--------|---------|-------|-----|------|--|
| | $\nabla=0$ $\nabla=0$ | <table border="1"> <thead> <tr> <th></th> <th>mm</th> <th>INCH</th> </tr> </thead> <tbody> <tr> <td>4 PLACES</td> <td>± .005</td> <td>± .0005</td> </tr> <tr> <td>3 PLACES</td> <td>± .005</td> <td>± .0005</td> </tr> <tr> <td>2 PLACES</td> <td>± .005</td> <td>± .0005</td> </tr> <tr> <td>1 PLACE</td> <td>± .005</td> <td>± .0005</td> </tr> </tbody> </table> ANGULAR $\pm 1/2^\circ$ | | mm | INCH | 4 PLACES | ± .005 | ± .0005 | 3 PLACES | ± .005 | ± .0005 | 2 PLACES | ± .005 | ± .0005 | 1 PLACE | ± .005 | ± .0005 | IN/MM | 4:1 | INCH | |
| | | mm | INCH | | | | | | | | | | | | | | | | | | |
| | 4 PLACES | ± .005 | ± .0005 | | | | | | | | | | | | | | | | | | |
| 3 PLACES | ± .005 | ± .0005 | | | | | | | | | | | | | | | | | | | |
| 2 PLACES | ± .005 | ± .0005 | | | | | | | | | | | | | | | | | | | |
| 1 PLACE | ± .005 | ± .0005 | | | | | | | | | | | | | | | | | | | |
| | | | DRAWN BY: RPACIFICI DATE: 2005/12/22 CHECKED BY: DATE: APPROVED BY: DATE: | TITLE: SC TYPE ADAPTER | | | | | | | | | | | | | | | | | |
| REV: B2 | | DRAFT WHERE APPLICABLE MUST REMAIN WITHIN DIMENSIONS | MATERIAL NO. SEE TABLE | DOCUMENT NO. SD-10616X-X000 | MOLEX INCORPORATED SHEET NO. 1 OF 01 | | | | | | | | | | | | | | | | |

9 8 7 6 5 4 3 2 1