

**FEATURES**

- low differential gain: 0.03% typ. at 4.43 MHz
- low differential phase: 0.012 deg. typ. at 4.43 MHz
- low insertion loss: 0.05 dB max at 100 kHz
- low disabled power consumption: 5.2 mW typ.
- high off isolation: 110 dB at 10 MHz
- all hostile crosstalk @ 5 MHz, 97 dB typ.
- bandwidth (-3dB) with 30 pF load, 100 MHz typ.
- fast make-before-break switching: 200 ns typ.
- TTL and 5 volt CMOS compatible logic inputs
- low cost 14 pin DIP and 16 pin SOIC packages
- optimised performance for NTSC, PAL and SECAM applications
- Pb-free and Green

**APPLICATIONS**

Glitch free analog switching for...

- High quality video routing
- A/D input multiplexing
- Sample and hold circuits
- TV/ CATV/ monitor switching

**AVAILABLE PACKAGING**

14 pin DIP and 16 pin SOIC (wide)

**FUNCTIONAL BLOCK  
DIAGRAM**

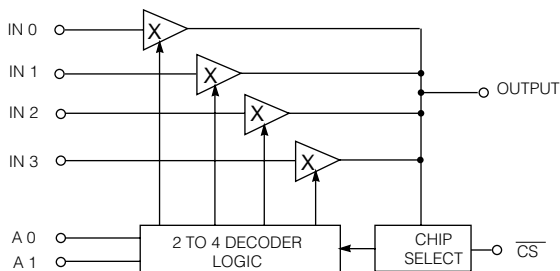

**CIRCUIT DESCRIPTION**

The GX434 is a high performance low cost monolithic 4x1 video multiplexer incorporating four bipolar switches with a common output, a 2 to 4 address decoder and fast chip select circuitry. The chip select input allows for multi-chip paralleled operation in routing matrix applications. The chip is selected by applying a logic 0 on the chip select input.

Unlike devices using MOS bilateral switching elements, these bipolar circuits represent fully buffered, unilateral transmission paths when selected. This results in extremely high output to input isolation. They also feature fast make-before-break switching action. These features eliminate such problems as switching 'glitches' and output-to-input signal feedthrough.

The GX434 operates from ±7 to ± 13.2 volt DC supplies. They are specifically designed for video signal switching which requires extremely low differential phase and gain. Logic inputs are TTL and 5 volt CMOS compatible providing address and chip select functions. When the chip is not selected, the output goes to a high impedance state.

**PIN CONNECTIONS**

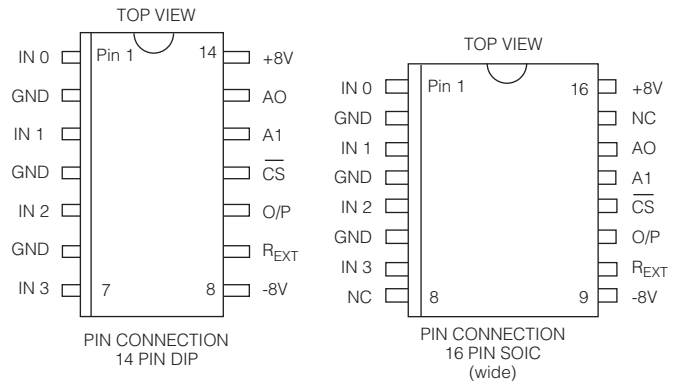

**GX434**

**TRUTH TABLE**

CS	A1	A0	OUTPUT
0	0	0	IN 0
0	0	1	IN 1
0	1	0	IN 2
0	1	1	IN 3
1	X	X	HI - Z

X = DONT CARE

## ABSOLUTE MAXIMUM RATINGS

Parameter	Value & Units
Supply Voltage	$\pm 13.5V$
Operating Temperature Range	$0^{\circ}C \leq T_A \leq 70^{\circ}C$
Storage Temperature Range	$-65^{\circ}C \leq T_S \leq 150^{\circ}C$
Lead Temperature (Soldering, 10 Sec)	$260^{\circ}C$
Analog Input Voltage	$-4V \leq V_{IN} \leq +2.4V$
Analog Input Current	$50\mu A$ AVG, 10 mA peak
Logic Input Voltage	$-4V \leq V_L \leq +5.5V$

## ORDERING INFORMATION

Part Number	Package Type	Temperature Range	Pb-Free and Green
GX434 -- CDB	14 Pin DIP	$0^{\circ}$ to $70^{\circ}C$	No
GX434 -- CKC	16 Pin SOIC	$0^{\circ}$ to $70^{\circ}C$	No
GX434 -- CTC	Tape 16 Pin SOIC	$0^{\circ}$ to $70^{\circ}C$	No
GX434 -- CKCE3	16 pin SOIC	$0^{\circ}$ to $70^{\circ}C$	Yes

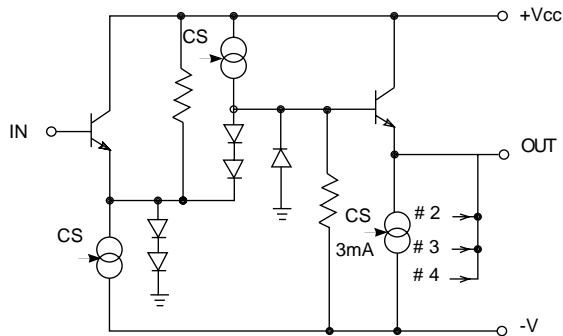
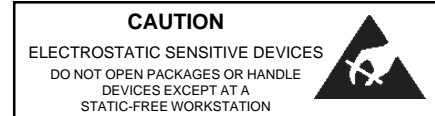

Fig. 1 Crosspoint Equivalent Circuit

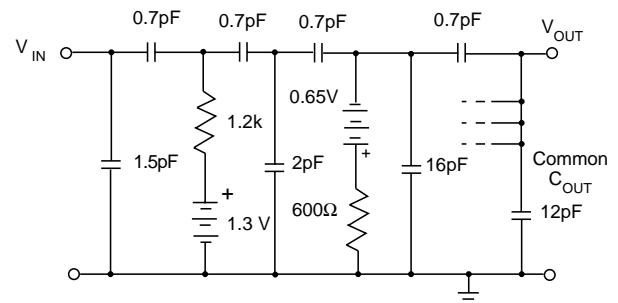

Fig. 2 Disabled Crosspoint Equivalent Circuit

## ELECTRICAL CHARACTERISTICS $V_S = \pm 8V$ DC, $0^{\circ}C < T_A < 70^{\circ}C$ , $C_L = 30$ pF, $R_L = 10k\Omega$ unless otherwise shown.)

				GX434			
	PARAMETER	SYMBOL	CONDITIONS	MIN	TYP	MAX	UNITS
DC SUPPLY	Supply Voltage	$\pm V_S$		7	8	13.2	V
	Supply current	I+	Chip selected ( $\overline{CS}=0$ )	-	10.5	11.5	mA
			Chip not selected ( $\overline{CS}=1$ )	-	0.4	0.58	mA
	Supply current	I-	Chip selected ( $\overline{CS}=0$ )	-	10.2	11.2	mA
Chip not selected ( $\overline{CS}=1$ )			-	0.25	0.38	mA	
STATIC	Analog Output	$V_{OUT}$	Extremes before clipping occurs.	-	+2 -	- -1.2	V
	Analog Input Bias Current	$I_{BIAS}$		-	22	-	$\mu A$
	Output Offset Voltage	$V_{OS}$	$T_A = 25^{\circ}C$ , 75 $\Omega$ resistor on each input to gnd	0	7	14	mV
	Output Offset Voltage Drift	$\Delta V_{OS}/\Delta T$		-	+50	+200	$\mu V/^{\circ}C$

$R_{EXT} = 33.2$  k $\Omega$ , 1%

**ELECTRICAL CHARACTERISTICS continued** ( $V_S = \pm 8V$  DC,  $0^\circ C < T_A < 70^\circ C$ ,  $C_L = 30pF$ ,  $R_L = 10k\Omega$  unless otherwise shown.)

				GX434			
	PARAMETER	SYMBOL	CONDITIONS	MIN	TYP	MAX	UNITS
LOGIC	Crosspoint Selection Turn-On Time	$t_{ADR-ON}$	Control input to appearance of signal at the output.	130	200	270	ns
	Crosspoint Selection Turn-Off Time	$t_{ADR-OFF}$	Control input to disappearance of signal at output.	390	600	800	ns
	Chip Selection Turn-On Time	$t_{CS-ON}$	Control input to appearance of signal at output.	200	300	400	ns
	Chip Selection Turn-Off Time	$t_{CS-OFF}$	Control input to disappearance of signal at output.	460	700	940	ns
	Logic Input Thresholds	$V_{IH}$	1	2.0	-	-	V
		$V_{IL}$	0	-	-	1.1	V
	Address Input Bias Current	$I_{BIAS(ADR)}$	Chip selected $A0, A1 = 1$	-	-	5.0	$\mu A$
Chip selected $A0, A1 = 0$			-	-	0.1	nA	
Chip Select Bias Current	$I_{BIAS(CS)}$	$\overline{CS} = 1$	-	-	1.0	nA	
		$CS = 0$	-	-	30	$\mu A$	
DYNAMIC	Insertion Loss	I.L.	1V p-p sine or sq. wave at 100 kHz	0.025	0.03	0.04	dB
	Bandwidth (-3 dB)	B.W.		100	120	-	MHz
	Gain Spread at 8 MHz			-	-	+0.06	dB
	Input to Output Signal Delay Matching (chip to chip)	$\Delta t_p$	$T_A = 25^\circ C$ , $R_S = 75\Omega$ $f = 3.579545$ MHz	-	-	$\pm 0.15$	degrees
			$0^\circ C < T_A < 70^\circ C$ , $R_S$ as above, $f$ as above.	-	-	$\pm 0.3$	degrees
	Input Resistance	$R_{IN}$	Chip selected ( $CS = 0$ )	900	-	-	k $\Omega$
	Input Capacitance	$C_{IN}$	Chip selected ( $CS = 0$ )	-	2.0	-	pF
			Chip not selected ( $\overline{CS} = 1$ )	-	2.4	-	pF
	Output Resistance	$R_{OUT}$	Chip selected ( $\overline{CS} = 0$ )	-	14	-	$\Omega$
	Output Capacitance	$C_{OUT}$	Chip not selected ( $CS = 1$ )	-	15	-	pF
	Differential Gain	dg	at 3.579545 MHz $V_{IN} = 40$ IRE, (Fig. 7)	-	0.03	0.05	%
	Differential Phase	dp		-	0.012	0.025	degrees
	All Hostile Crosstalk (see graph)	$X_{TALK(AH)}$	Sweep on 3 inputs 1V p-p 4th input has 10 $\Omega$ resistor to gnd. $f = 5$ MHz (Fig. 6)	94	97	-	dB
Chip Disabled Crosstalk (see graph)	$X_{TALK(CD)}$	$f = 10$ MHz (Fig. 5)	100	110	-	dB	
Slew Rate	+SR	$V_{IN} = 3V$ p-p ( $C_L = 0$ pF)	360	450	-	V/ $\mu s$	
	-SR		160	200	-	V/ $\mu s$	

$R_{EXT} = 33.2k\Omega$ , 1%

GX434

## TYPICAL PERFORMANCE CURVES OF THE GX434

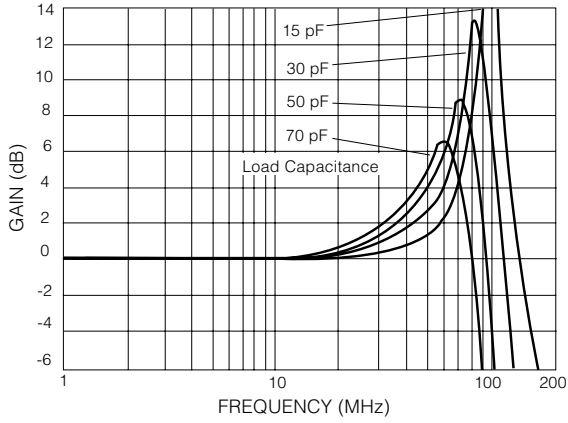

Gain vs Frequency

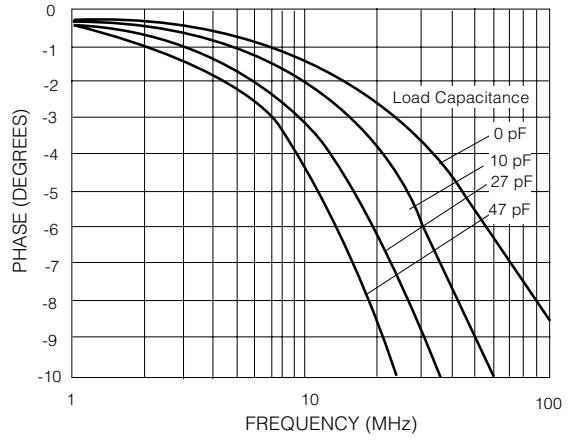

Phase vs Frequency

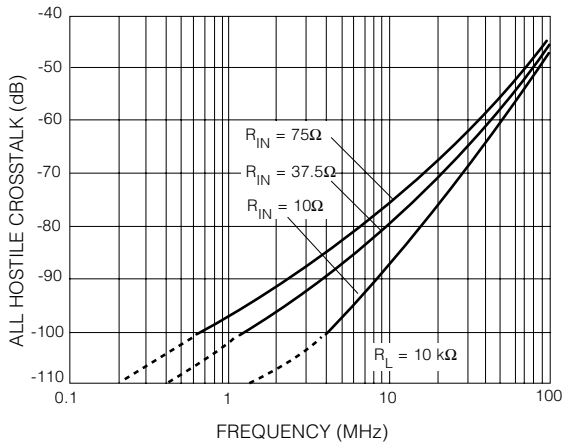

All Hostile Crosstalk (14 pin DIP)

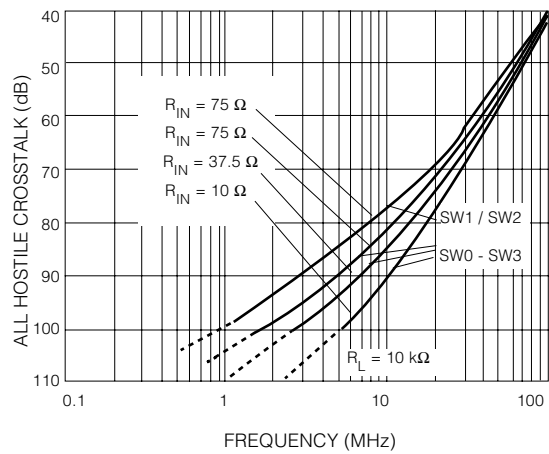

All Hostile Crosstalk (16 pin SOIC)

For all graphs,  $V_S = \pm 8 \text{ V DC}$  and  $T_A = 25^\circ\text{C}$ . The curves shown above represent typical batch sampled results.

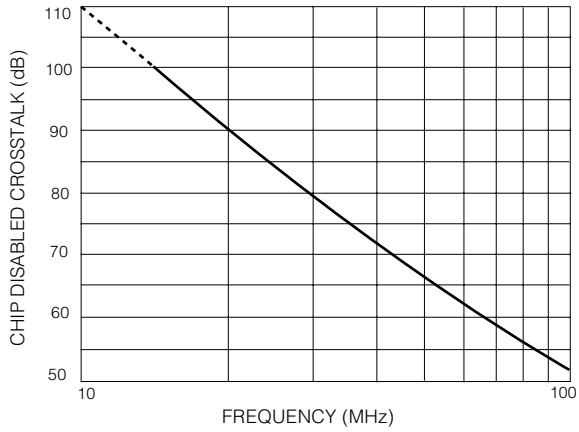

Chip Disabled Crosstalk vs Frequency

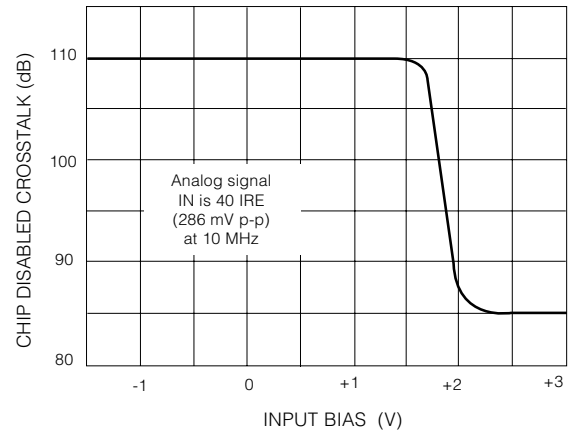

Chip Disabled Crosstalk vs Input Bias (V)

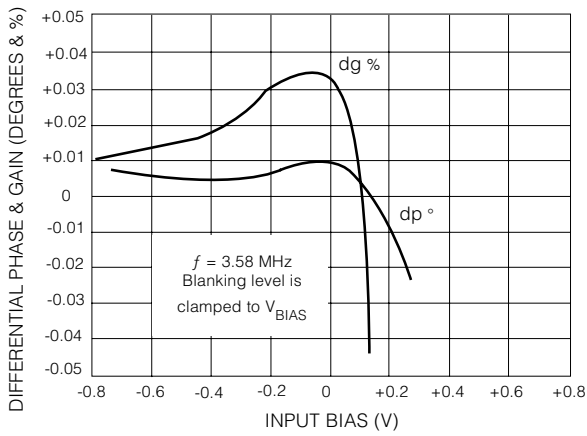

dg/dp vs Input Bias

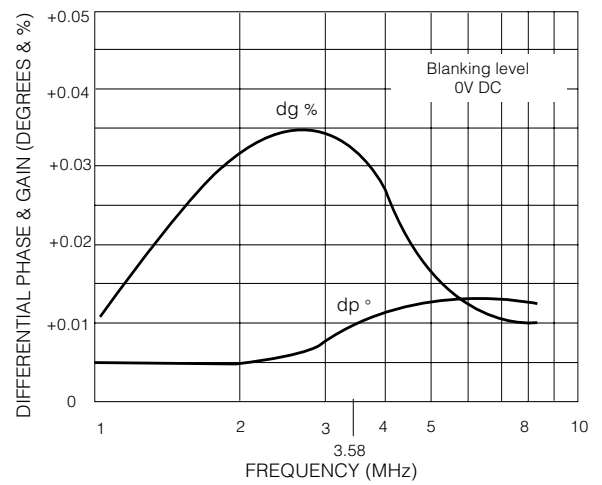

dg/dp vs Frequency

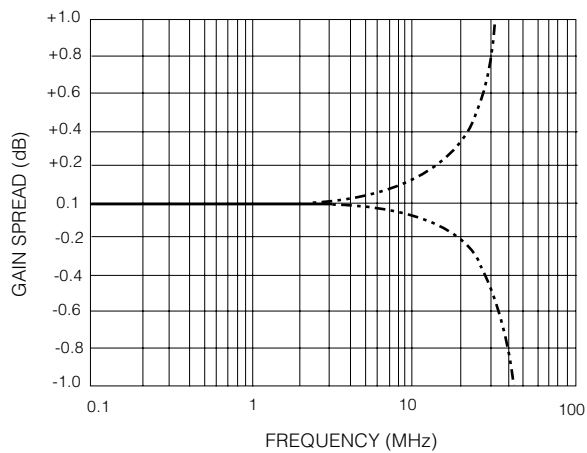

Normalized Gain Spread  $C_L = 30\text{pF}$

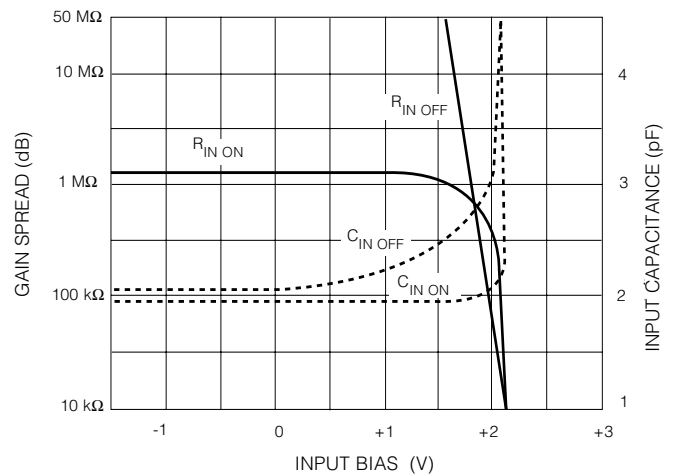

Input Impedance

GX434

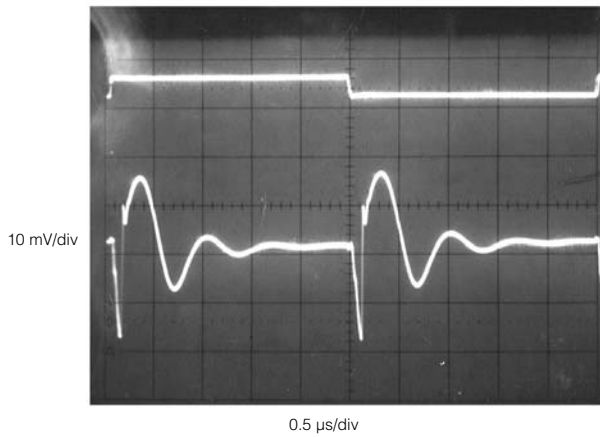

Fig.3 Switching Transient (crosspoint to crosspoint)

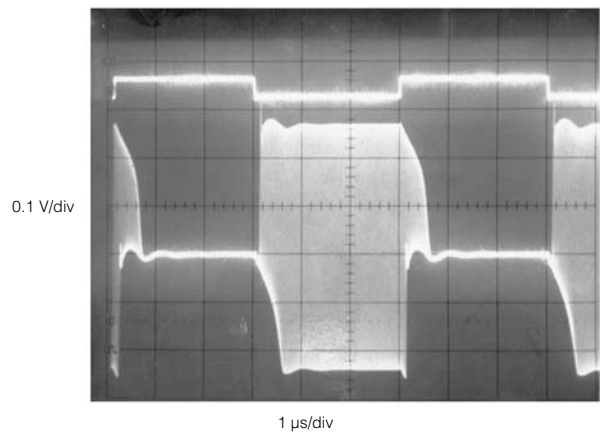

Fig. 4 Switching Envelope (crosspoint to crosspoint)

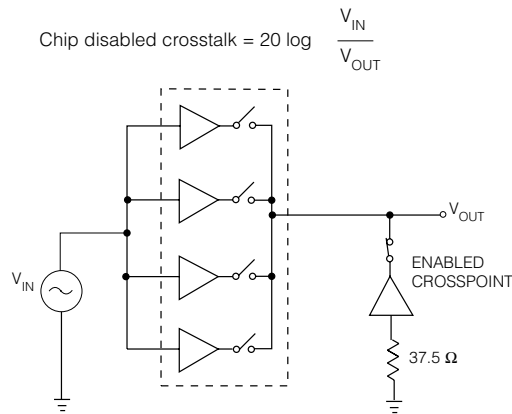

Fig. 5 Chip Disabled Crosstalk Test Circuit

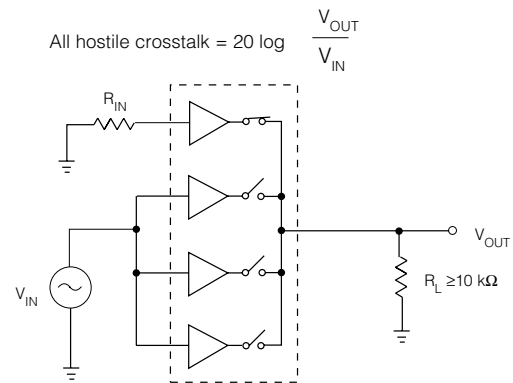

Fig. 6 All Hostile Crosstalk Test Circuit

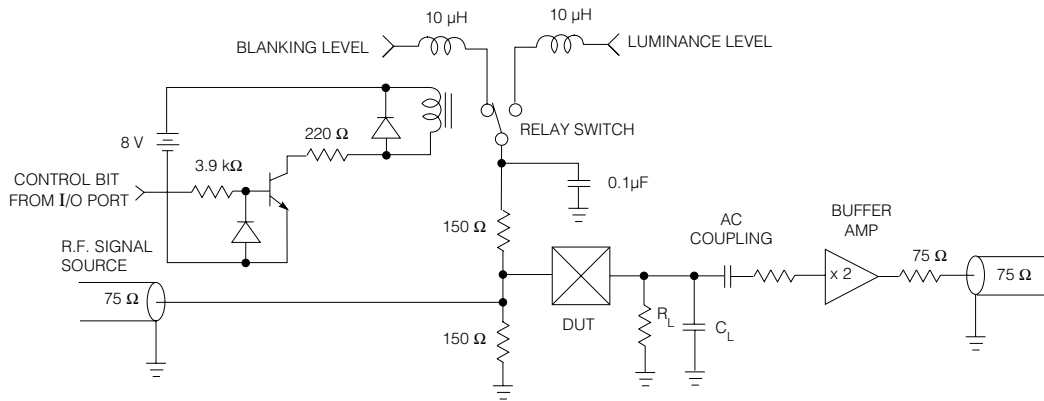

Fig. 7 Differential Phase and Gain Test Circuit

### DIFFERENTIAL GAIN AND PHASE TEST CIRCUIT

The test circuit of Figure 7 allows two DC bias levels, set by the user, to be superimposed on a high frequency signal source. A computer controlled relay selects either the preset blanking or luminance level. One measurement is taken at each level and the change in gain or phase is calculated. This procedure is repeated one hundred times to provide a reasonably large sample.

The results are averaged to reduce the standard deviation and therefore improve the accuracy of the measurement.

The output from the device under test is AC coupled to a buffer amplifier which allows the buffer to operate at a constant luminance level so that it does not contribute any dg or dp to the measurement.

## OPTIMISING THE PERFORMANCE OF THE GX434

### 1. Power Supply Considerations

Table 1 shows the effect on differential gain (dg) and differential phase (dp) of various power supply voltages that may be used. A nominal supply voltage of  $\pm 8$  volts result in parameter values as shown in the top row of the table. By using other power supply voltage combinations, improvements to these parameters are possible at the sacrifice of increased chip power dissipation. Maximum degradation of the differential gain and phase occurs for the last combination of +12, -7 volts along with an increase in power dissipation; these voltages are not recommended.

Supply Voltage	Differential Gain % (Typical)	Differential Phase degrees (Typical)
$\pm 8$	0.030	0.012
+8/ -12	0.010	0.007
$\pm 12$	0.010	0.007
+12/ -7	0.084	0.080

Table 2 shows the general characteristic variations of the GX434 when different combinations of power supply voltages are used. These changes are relative to a circuit using  $\pm 8$  volts Vcc.

Supply Voltage	Characteristic Changes
$\pm 7$	<ul style="list-style-type: none"> <li>- lower logic thresholds</li> <li>- max logic I/P (<math>\approx 4.5V</math>)</li> <li>- loss of off isolation (<math>\approx 20</math> dB)</li> <li>- poorer dg and dp</li> </ul>
+8/ -12	<ul style="list-style-type: none"> <li>- slight increase in negative supply current</li> <li>- slight decrease in offset</li> <li>- very similar frequency response</li> <li>- better dg and dp</li> </ul>
$\pm 12$	<ul style="list-style-type: none"> <li>- increase in supply current (10%)</li> <li>- increase in offset (<math>\approx 2-4</math> mV)</li> <li>- very similar frequency response</li> <li>- better dg and dp</li> </ul>
+12/ -7	<ul style="list-style-type: none"> <li>- loss in off isolation (<math>\approx 20</math> dB)</li> <li>- poorer dg and dp</li> </ul>

The GX434 does not require input DC biasing to optimise dg or dp nor does it need switching transient suppression at the output. Furthermore, both the analog signal and logic circuits within the chip use one common power supply, making power supply configurations relatively simple and straight-forward. Several of the input characteristic graphs on pages 4-5 show that for best operation, the input bias should be 0 volts. The switching transient photographs on page 6 show how small the actual transients are and clearly show the make-before-break action of the GX434 video multiplexer switch.

## 2. Load Resistance Considerations

The GX434 crosspoint switch is optimised for load resistances equal to or greater than 3 kΩ. Figure 8 shows the effect on the differential gain and phase when the load resistance is varied from 100 Ω to 100 kΩ.

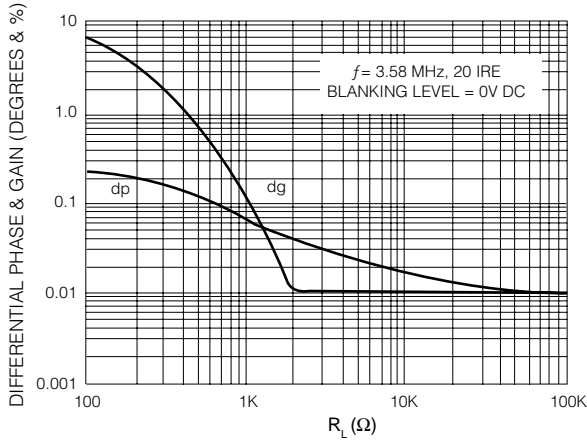

Fig. 8 dg/dp vs  $R_L$

The negative slew rate is dependant upon the output current and load capacitance as shown below.

$$-SR = \frac{I + 3 \text{ mA}}{C_L} \quad I \leq 8 \text{ mA}$$

The current  $I$  is determined from the following equation:

$$I = \frac{-V_{EE}}{R} \quad R \geq 1 \text{ k}\Omega$$

It is possible to increase the negative slew rate (-S.R.) and thus the large signal bandwidth, by adding a resistance from the output to  $-V_{EE}$ . This resistor increases the output current above the 3 mA provided by the internal current generator and increases the negative slew rate. The additional slew rate improving resistance must not be less than 1kΩ in order to prevent excessive currents in the output of the device. An adverse effect of utilising this negative slew rate improving resistor, is the increase in differential phase from typically 0.009° to 0.014°. Under these same conditions, the differential gain drops from typically 0.033 % to 0.021 %.

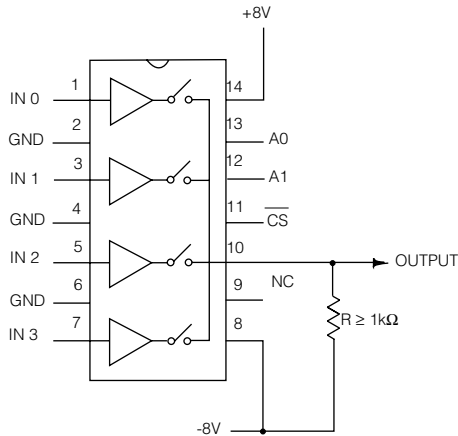

Fig.9 Negative Slew Rate (-SR) Improvement

## 3. Multi-chip Considerations

Whenever multi-chip bus systems are to be used, the total input and output capacitance must be carefully considered. The input capacitance of an enabled crosspoint (chip selected), is typically only 2 pF and increases slightly to 2.4 pF when the chip is disabled. The total output capacitance when the chip is disabled is approximately 15 pF per chip.

Usually the GX434 multiplexer switch is used in a matrix configuration of (n x 1) crosspoints perhaps combined in an (n x m) total routing matrix. This means for example, that four ICs produce a 16 x 1 configuration and have a total output capacitance of 4 x 15 pF or 60 pF if all four chips are disabled. For any one enabled crosspoint, the effective load capacitance will be 3 x 15 pF or 45 pF.

In a multi-input/multi-output matrix, it is important to consider the total input bus capacitance. The higher the bus capacitance and the more it varies from the ON to OFF condition, the more difficult it is to maintain a wide frequency response and constant drive from the input buffer. A 16 x 16 matrix using 64 ICs (16 x 4), would have a total input bus capacitance of 16 x 2.4 pF or 40 pF.

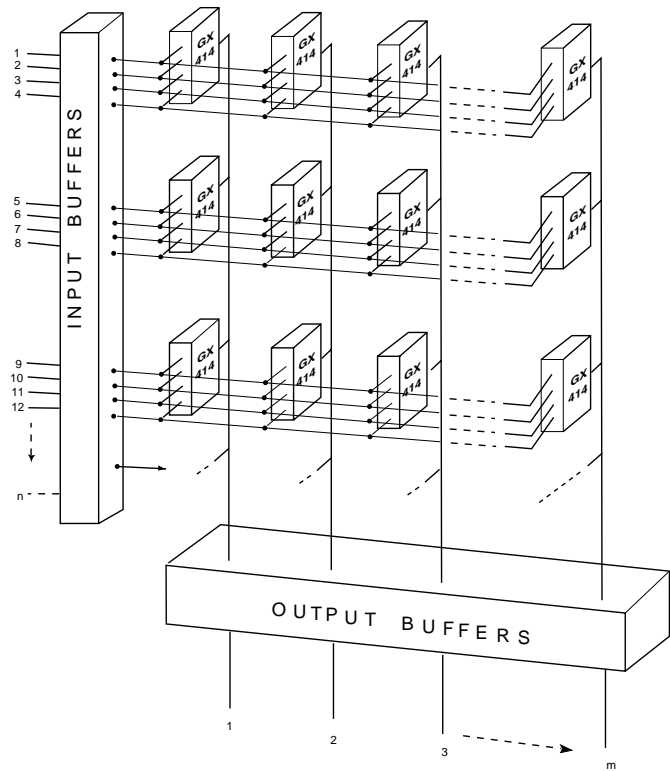

Fig.10 Multi-chip Connections



## APPLICATIONS INFORMATION

The GX434 multiplexer is a very high performance, wideband circuit requiring careful external circuit design. Good power supply regulation and decoupling are necessary to achieve optimum results. The circuit designer must use proper lead dress, component placement and PCB layout as in any high frequency circuit.

Functionally, the video switches are non-inverting, unity gain bipolar switches with buffered inputs requiring DC coupling and 75Ω line terminating resistors when directly driven from 75Ω cable. The output must be buffered to drive 75Ω lines. This is usually accomplished with the addition of an operational amplifier/ buffer which also allows adjustments to be made to the gain, offset and frequency response of the overall circuit.

A typical video routing application is shown in Figure 11. Four ICs are used in a 16 x 1 multiplexer switching circuit.

An external address decoder is shown which generates the 16 address and chip enable codes from a binary number. The address inputs to each chip are active high while the chip select inputs are active low. Depending on the application and speed of the logic family used, latches may be required for synchronization where timing and delays are critical. Since the individual crosspoint switching circuits are unidirectional bipolar elements, low crosstalk and high isolation are inherent. The make-before-break switching characteristics of the GX434 means virtually 'glitch' free switching.

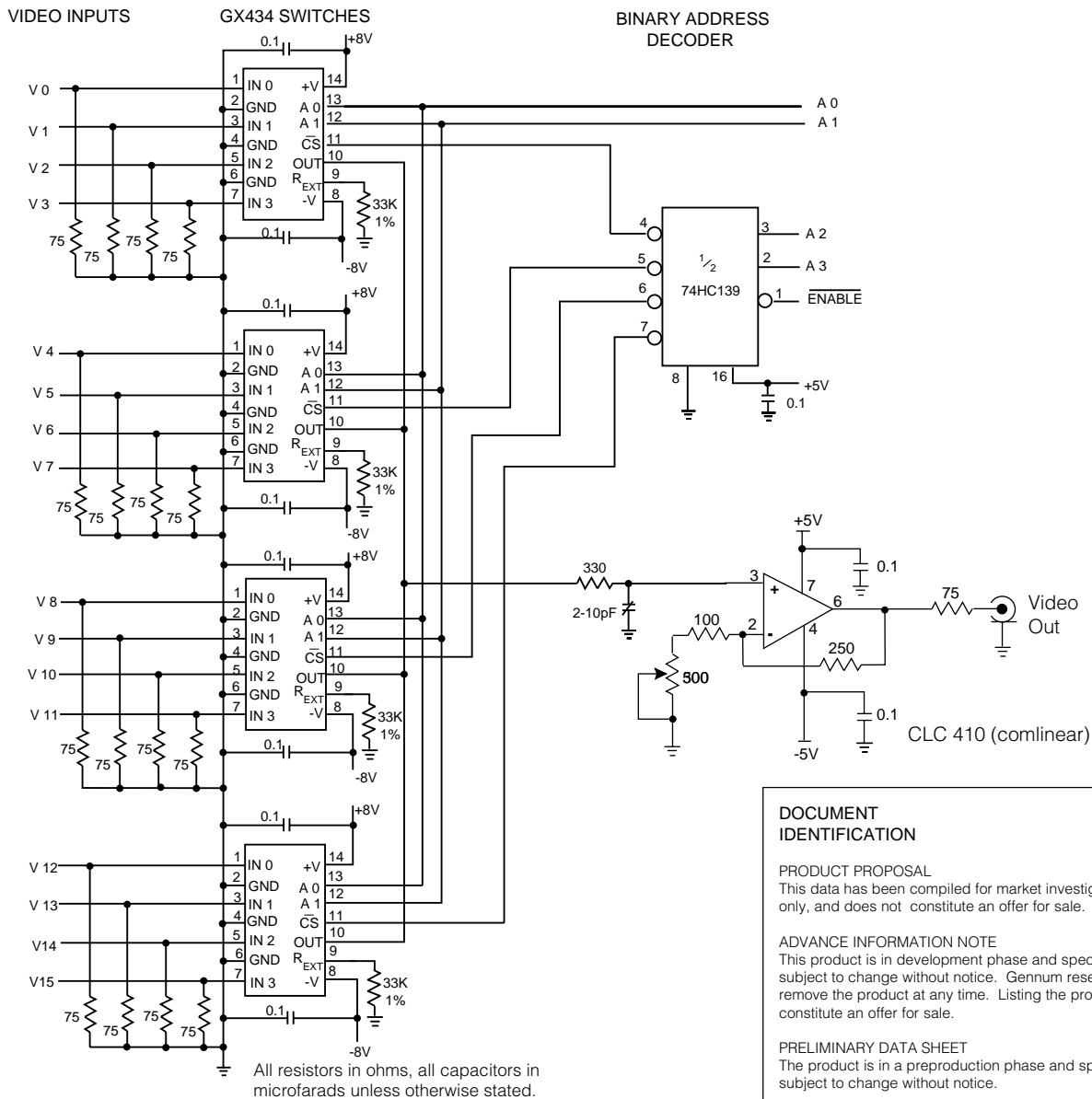

Fig.11 16 x 1 Video Multiplexer Circuit

### DOCUMENT IDENTIFICATION

#### PRODUCT PROPOSAL

This data has been compiled for market investigation purposes only, and does not constitute an offer for sale.

#### ADVANCE INFORMATION NOTE

This product is in development phase and specifications are subject to change without notice. Gennum reserves the right to remove the product at any time. Listing the product does not constitute an offer for sale.

#### PRELIMINARY DATA SHEET

The product is in a preproduction phase and specifications are subject to change without notice.

#### DATA SHEET

The product is in production. Gennum reserves the right to make changes at any time to improve reliability, function or design, in order to provide the best product possible.

GX434