

NOTES:

- HOUSING MATERIAL : GLASS FILLED LIQUID CRYSTAL POLYMER (LCP);
UL RATING: 94V-0; COLOR: WHITE
TERMINAL MATERIAL: PHOSPHOR BRONZE
VACUUM CAP MATERIAL: STAINLESS STEEL
- COPLANARITY OF SMT TAILS: 0.10 MAX.
- PACKAGING SPECIFICATIONS : REFER TO TABLE.
- THIS PART, WHEN MATED WITH MOLEX U.S.PART NO. 71742-0*** OR MOLEX JAPAN PART NO. 52841-0848, CONFORMS TO MOLEX PRODUCT SPECIFICATION PS-71741-9999.

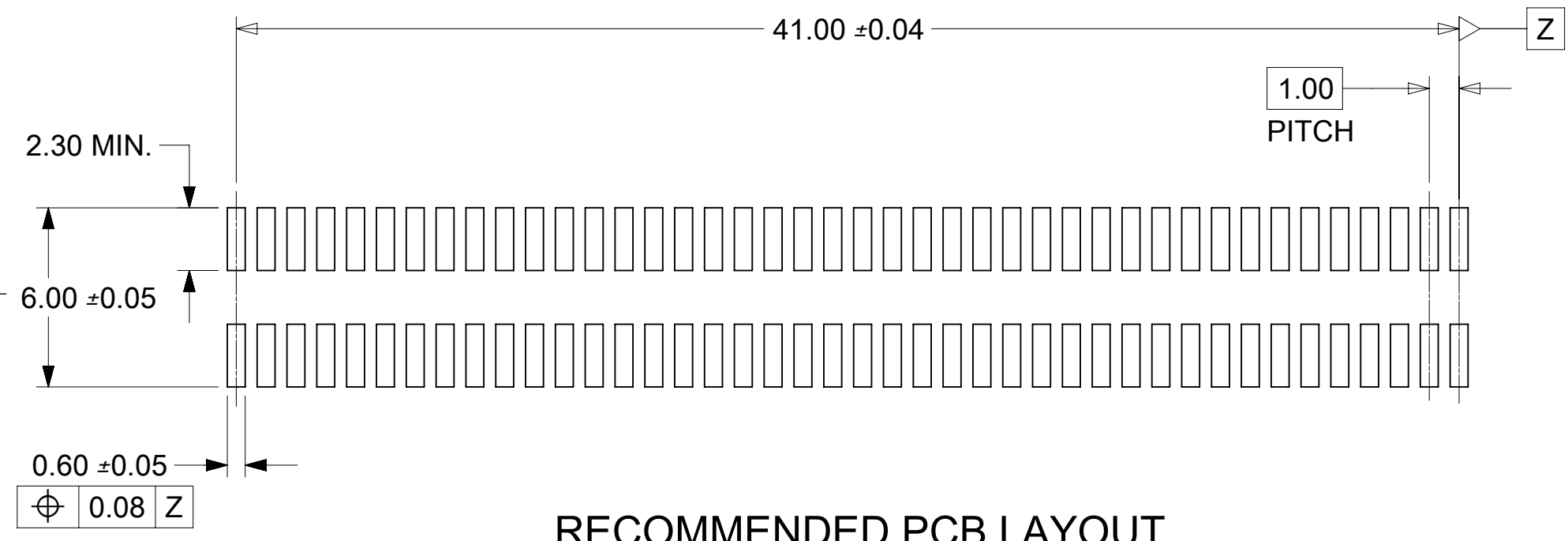
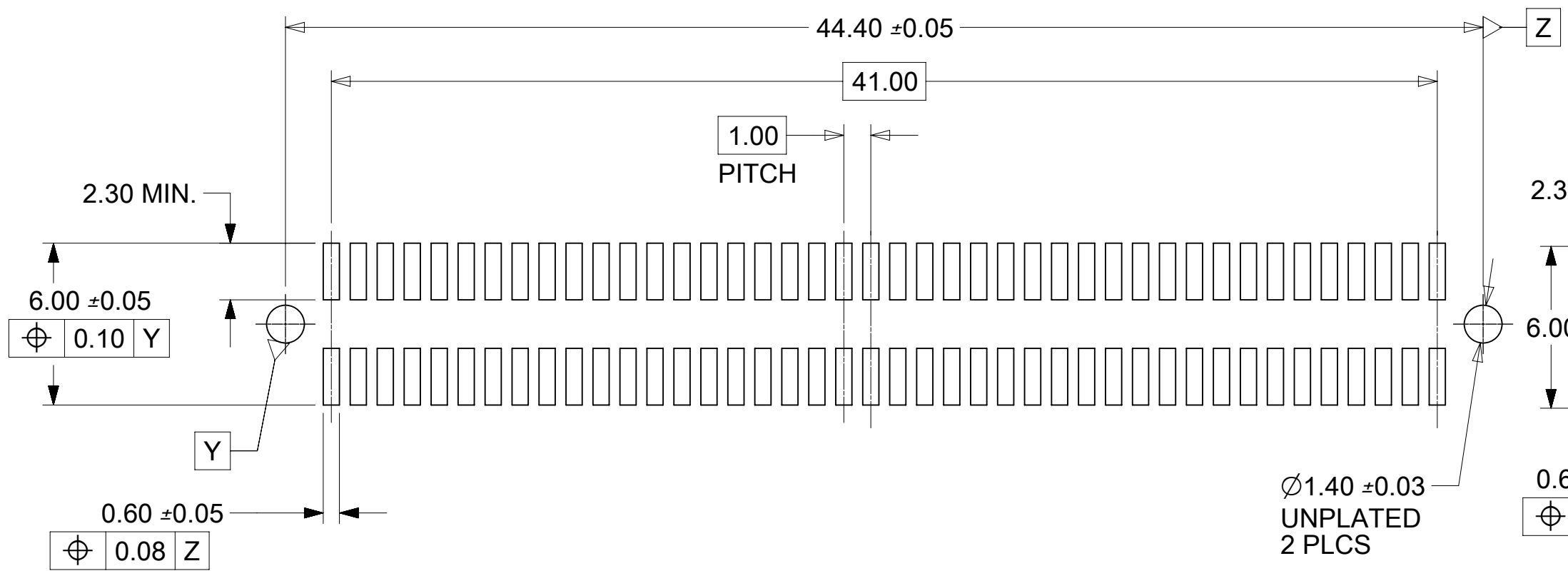
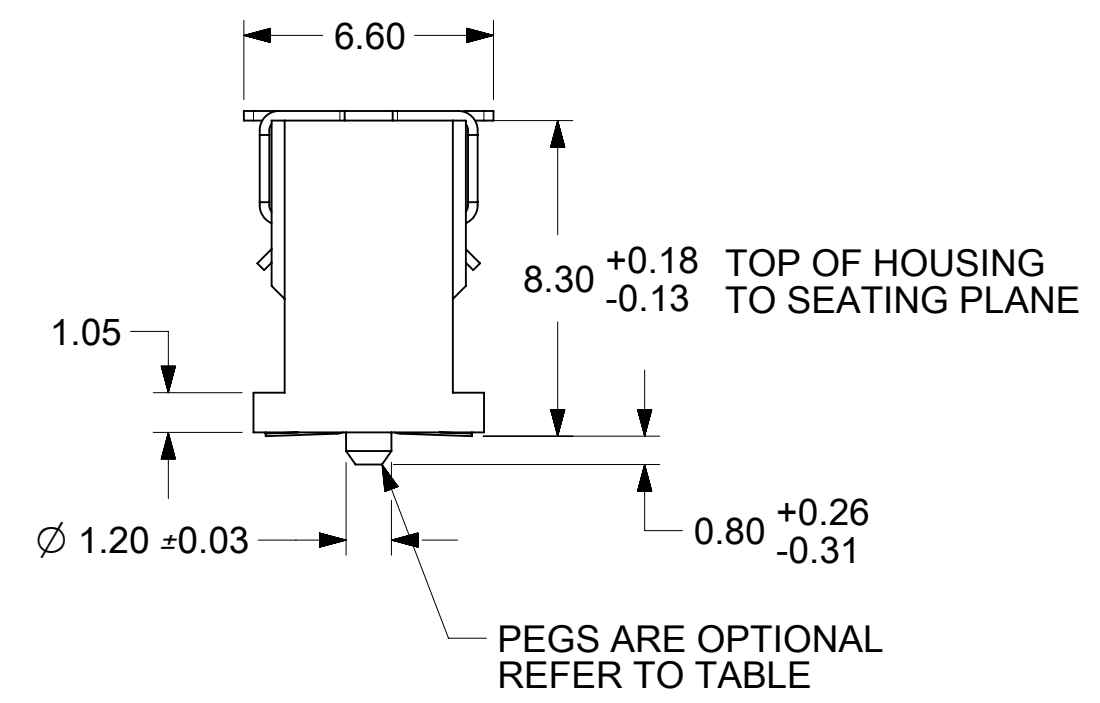
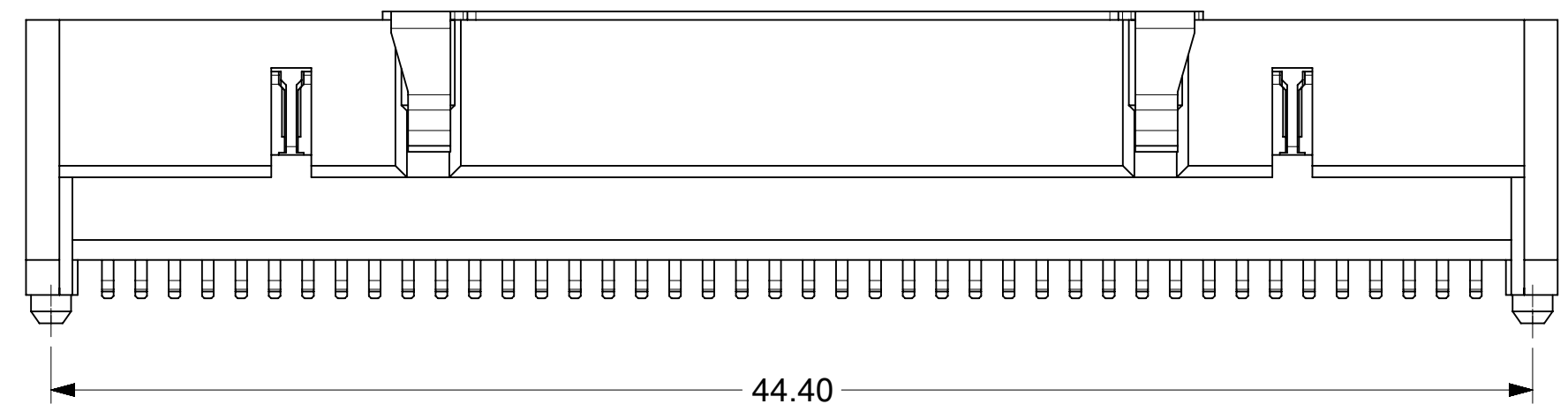

RECOMMENDED PCB LAYOUT WITH PEGS

RECOMMENDED PCB LAYOUT

RECOMMENDED PCB THICKNESS: 1.0±0.1 mm MIN.

RECOMMENDED PCB THICKNESS: 1.0±0.1 mm MIN.

PLATINGS:

- X21 - .76 MICROMETERS MINIMUM GOLD PLATE IN SELECT AREA, 1.91 MICROMETERS MINIMUM TIN PLATE IN SELECT AREA, OVER NICKEL UNDERPLATE.
- X71 - .25 MICROMETERS MINIMUM GOLD PLATE IN SELECT AREA, 1.02 MICROMETERS MINIMUM TIN PLATE IN SELECT AREA, OVER NICKEL UNDERPLATE.

SYMBOLS										THIS DRAWING CONTAINS INFORMATION THAT IS PROPRIETARY TO MOLEX ELECTRONIC TECHNOLOGIES, LLC AND SHOULD NOT BE USED WITHOUT WRITTEN PERMISSION																			
DIMENSION UNITS					SCALE					CURRENT REV DESC: REDRAWN IN NX																			
mm					5:1																								
GENERAL TOLERANCES (UNLESS SPECIFIED)																													
ANGULAR TOL ± 0.5°																													
4 PLACES ±										EC NO: 610884																			
3 PLACES ±										DRWN: TTAO03					2018/12/10														
2 PLACES ± 0.18										CHK'D: JKACHLIC					2019/02/01														
1 PLACE ± 0.33										APPR: JKACHLIC					2019/02/01														
0 PLACES ±										INITIAL REVISION:																			
DRAFT WHERE APPLICABLE MUST REMAIN WITHIN DIMENSIONS					THIRD ANGLE PROJECTION					DRAWING					SERIES														
					C-SIZE					71741																			
DOCUMENT STATUS										SALES ASSY, 1.0MM 84 CKT BTB PLUG 4.30 MM STACK HEIGHT																			
P1										PRODUCT CUSTOMER DRAWING																			
RELEASE DATE										DOCUMENT NUMBER					DOC TYPE					DOC PART					REVISION				
2019/02/01 01:16:46										717410000					PSD					000					A1				
MATERIAL NUMBER										CUSTOMER					SHEET NUMBER														
SEE TABLE										GENERAL MARKET					1 OF 2														

MATERIAL NUMBER	PEGS	PICK & PLACE CAP	PACKAGING SPEC. NUMBER	PACKAGING TYPE	TERMINAL PLATING SEE SHEET 1
71741-0004	YES	YES	PK-70873-063	TAPE & REEL	X71
71741-0003	NO	YES	PK-70873-063	TAPE & REEL	X71
71741-0002	YES	YES	PK-70873-063	TAPE & REEL	X21
71741-0001	YES	NO	PK-70873-0607	TUBE	X21

RECOMMENDED PLUG/RECEPTACLE COMBINATION FOR MATED STACK HEIGHT PER EIA STANDARD 700 AAAB

MATED STACK HEIGHT	RECEPTACLE HEIGHT	RECEPTACLE SERIES NO.	PLUG HEIGHT	PLUG SERIES NO.
10.00	5.30	71742-0***	4.30	71741-0***
12.00	7.30	71742-2***		
15.00	10.30	71742-3***		

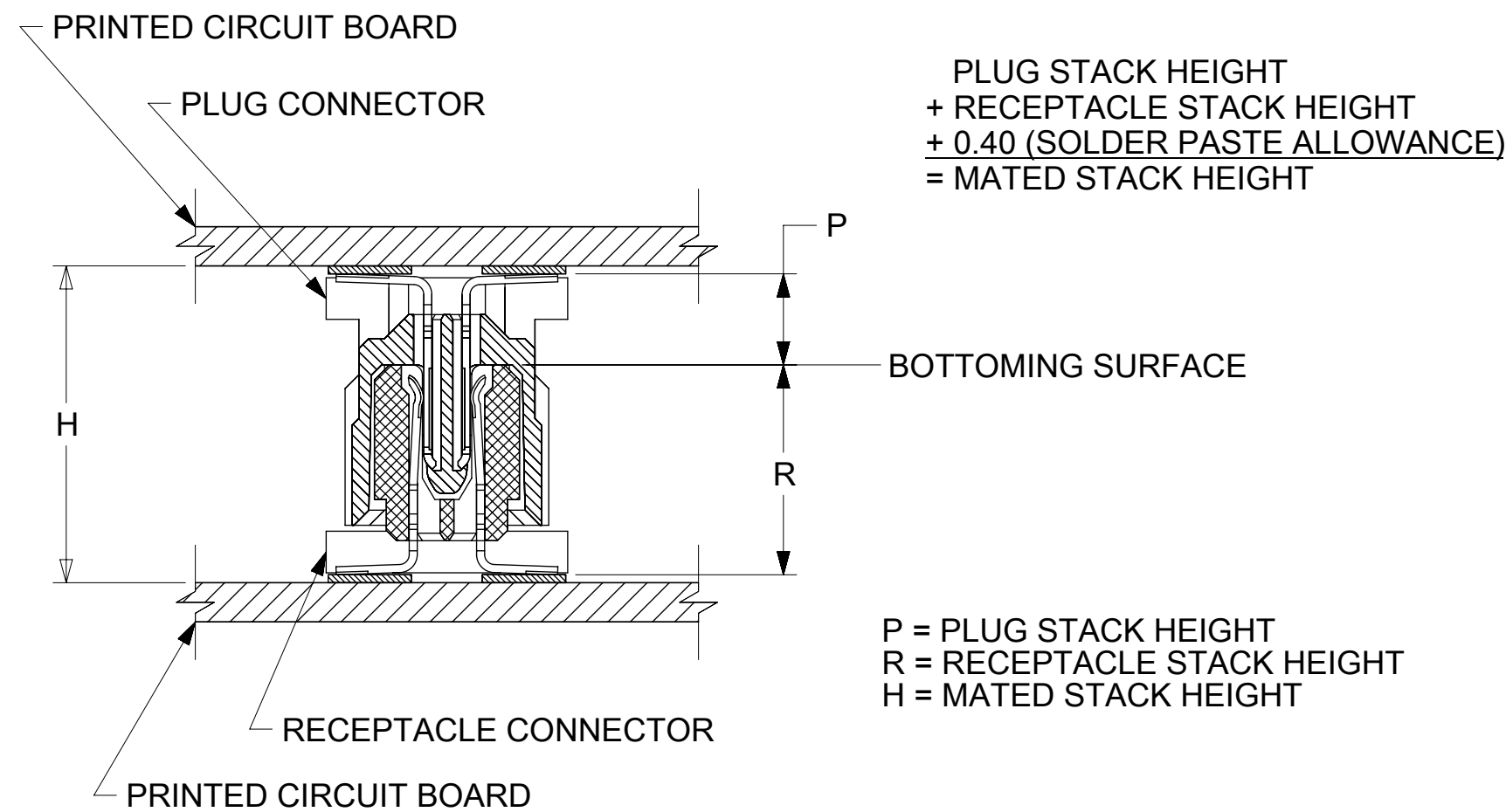

SYMBOLS	THIS DRAWING CONTAINS INFORMATION THAT IS PROPRIETARY TO MOLEX ELECTRONIC TECHNOLOGIES, LLC AND SHOULD NOT BE USED WITHOUT WRITTEN PERMISSION			
	DIMENSION UNITS	SCALE	CURRENT REV DESC: REDRAWN IN NX	
▽ = 0	mm		molex SALES ASSY, 1.0MM 84 CKT BTB PLUG 4.30 MM STACK HEIGHT	
▽ = 0	GENERAL TOLERANCES (UNLESS SPECIFIED)			
▽ = 0	ANGULAR TOL ± 0.5°		EC NO: 610884 DRWN: TTAO03 2018/12/10 CHK'D: JKACHLIC 2019/02/01 APPR: JKACHLIC 2019/02/01	
▽ = 0	4 PLACES ±		INITIAL REVISION: DRWN: JRR 95/08/14 APPR: CAB 95/08/14	
▽ = 0	3 PLACES ±			
▽ = 0	2 PLACES ± 0.18		PRODUCT CUSTOMER DRAWING DOCUMENT NUMBER: 717410000 DOC TYPE: PSD DOC PART: 000 REVISION: A1	
▽ = 0	1 PLACE ± 0.33			
▽ = 0	0 PLACES ±		MATERIAL NUMBER: SEE TABLE CUSTOMER: GENERAL MARKET SHEET NUMBER: 2 OF 2	
▽ = 0	DRAFT WHERE APPLICABLE MUST REMAIN WITHIN DIMENSIONS		THIRD ANGLE PROJECTION	DRAWING: C-SIZE
▽ = 0			SERIES: 71741	

RECOMMENDED PLUG/RECEPTACLE COMBINATION FOR
MATED STACK HEIGHT PER EIA STANDARD 700 AAAB

MATED STACK HEIGHT	RECEPTACLE HEIGHT	RECEPTACLE SERIES NO.	PLUG HEIGHT	PLUG SERIES NO.
10.00/.394	5.30/.209	71742-0***	4.30/.169	71741-0***
15.00/.591	10.30/.406	71742-3***	4.30/.169	71741-0***

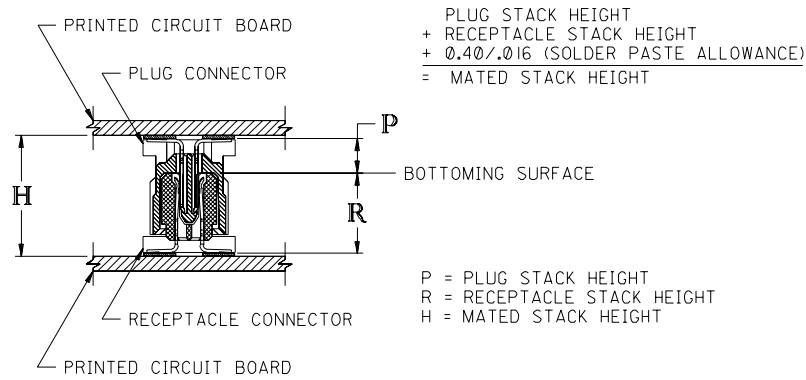

METRIC

REVISE ONLY ON CAD SYSTEM

UNLESS OTHERWISE SPECIFIED
TOLERANCES: ANGULAR ± 1/2°

	INCH	METRIC
3 PLACE	± ----	----
2 PLACE	± ----	± ----
1 PLACE	----	± ----

DRAFT WHERE APPLICABLE MUST
REMAIN WITHIN DIMENSIONS

TITLE SALES ASSY, 1.0mm 84 CKT. BOARD-TO-BOARD PLUG 4.30/.169 STACK HEIGHT		SHEET NO. 2	DATE 98/12/28
MOLEX INCORPORATED L15LEJLL 60532 U.S.A.		PART NO. SEE SHT 1	DRWG. NO. SDA-71741-0***
FILE NAME S717410 DGN	THIS DRAWING CONTAINS INFORMATION THAT IS PROPRIETARY TO MOLEX INC. AND SHOULD NOT BE USED WITHOUT WRITTEN PERMISSION		DIV. CPP

DRWG. BY KAS	CHK'D. BY KAS
APP'D. BY DJB	SCALE NONE

LTR.	REVISIONS	LTR.	REVISIONS
		D	SEE SHEET 1