

P	LTR	DESCRIPTION	DATE	DWN	APVD
D2		Released per ECR-20-011703	8/20/2020	FDP	TD

SPECIFICATIONS:

- BOTTOM CONTACT:
MAGNET WIRE: #27 - #35 AWG,
0.14[.006] - 0.38[.015] DIA COPPER.
TOP CONTACT:
BARE SOLID COPPER WIRE: 0.56[.022] DIA
- POCKET RECOMMENDATION #1601432
- TERMINAL APPLICATION TO COMPLY WITH TYCO ELECTRONICS SPECIFICATION 114-13166. CONSULT PRODUCT ENGINEERING.
- TWO(2) TERMINALS SHOWN FOR ILLUSTRATION PURPOSES ONLY.

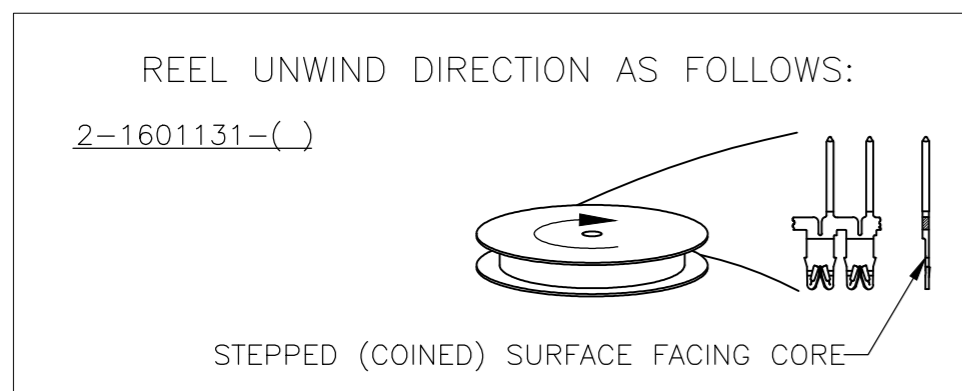
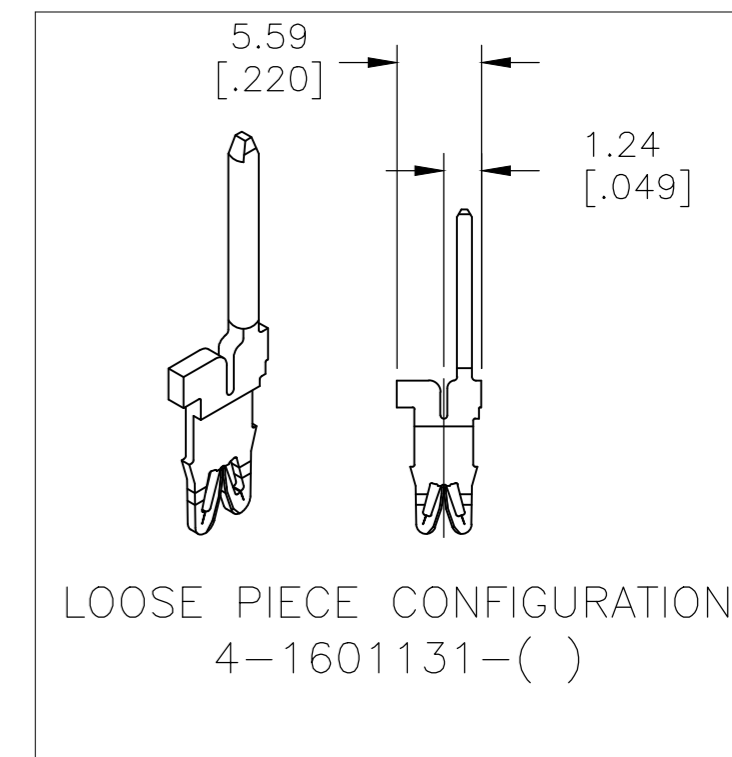
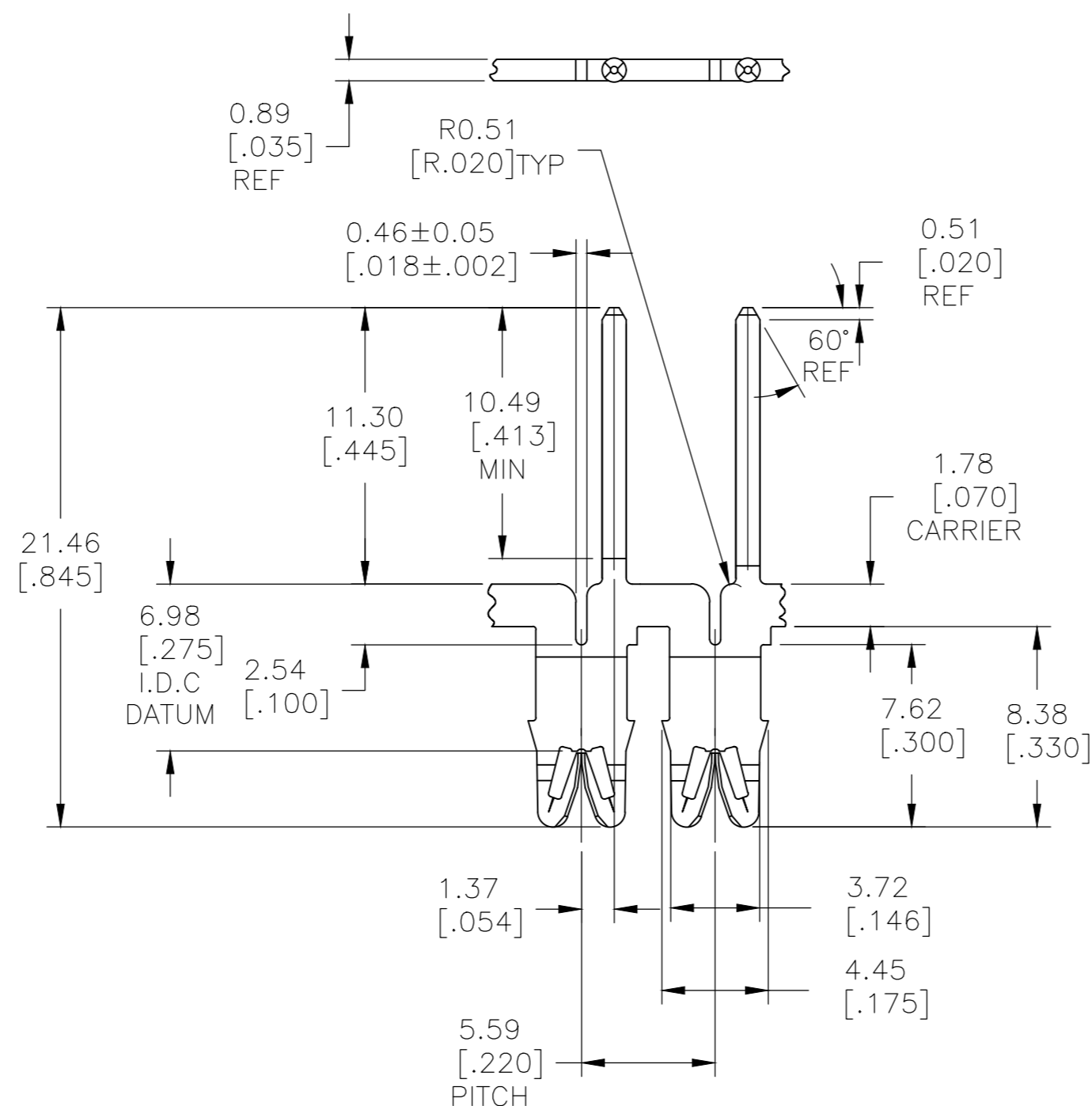
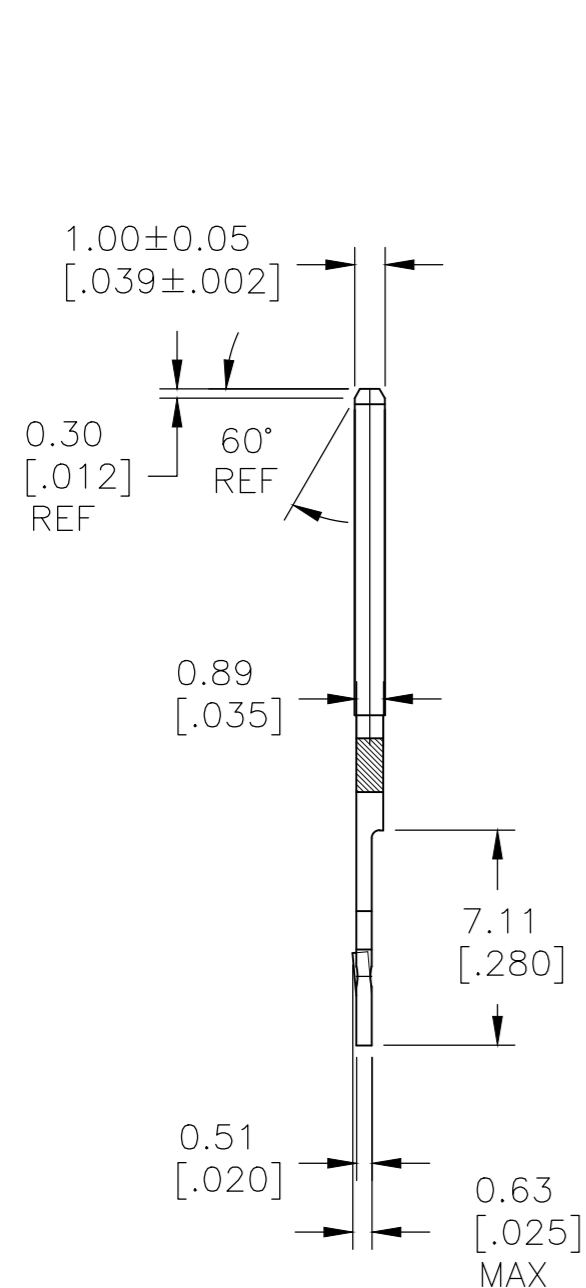

Pre-Tin Plate over Copper Underplate		150-028-014	2-1601131-2
FINISH		REFERENCE PART NUMBER	TE PART NUMBER
THIS DRAWING IS A CONTROLLED DOCUMENT.		TE Connectivity	
DIMENSIONS: mm [INCHES] TOLERANCES UNLESS OTHERWISE SPECIFIED: 0 PLC ± - 1 PLC ± - 2 PLC ± .005[0.13] 3 PLC ± - 4 PLC ± - ANGLES ± 2°			
MATERIAL: BRASS, 3/4 HARD		NAME: 1.0 MM DIA PIN TO FINE WIRE SIAMEZE TERMINAL SIZE: A2 CAGE CODE: 00779 DRAWING NO: C=1601131	
FINISH: SEE TABLE		WEIGHT: 0.000000 CUSTOMER DRAWING	
		SCALE: 1:6	SHEET 1 of 1 REV D2