

THIS DRAWING IS UNPUBLISHED  
 RELEASED FOR PUBLICATION 2017  
 © COPYRIGHT 2017 BY - TE CONNECTIVITY ALL RIGHTS RESERVED.

REVISIONS					
P	LTR	DESCRIPTION	DATE	DWN	APVD
	C	REVISED PER PCN E-17-012901	13JUN2017	CM	DM

CONTACT SIZE	MIN. INSUL. OD [mm]	MAX. INSUL. OD [mm]	WIRE RANGE [mm <sup>2</sup> ] REF ONLY
16	.053 [1.35]	.120 [3.05]	14-18 AWG [2.0-.75]

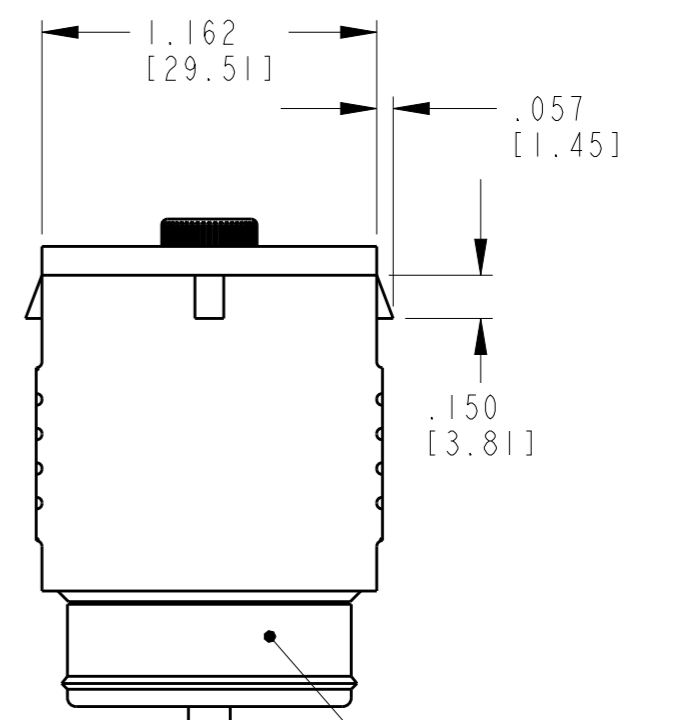
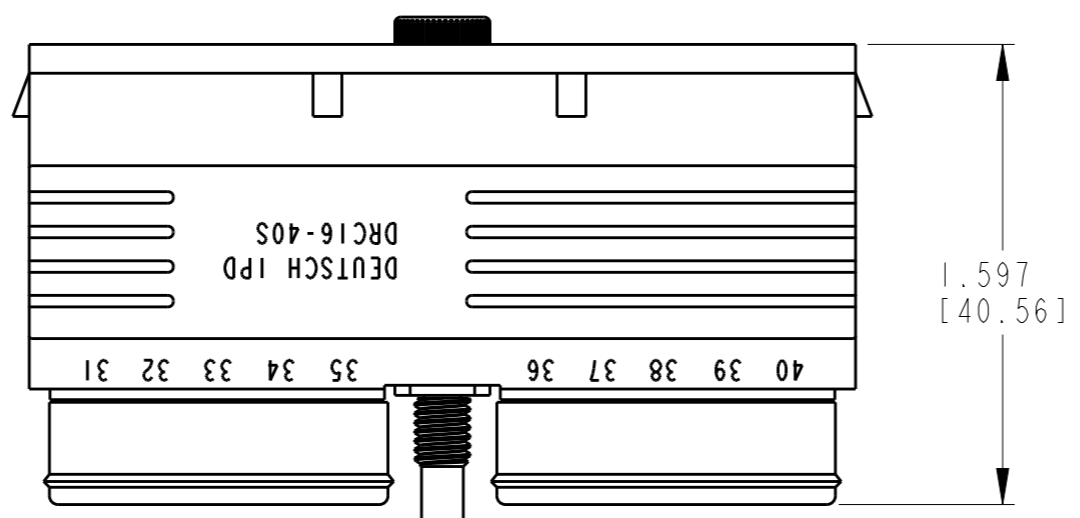
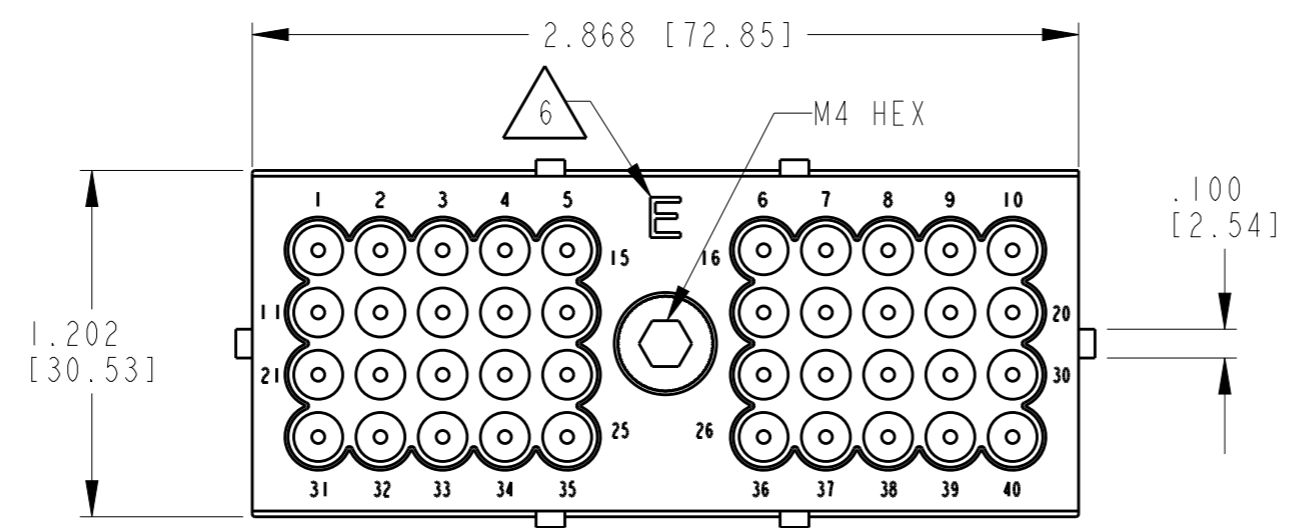

- 6. E: LETTER "E" IDENTIFIES "E" WIRE SEAL.
- 5. MATERIAL:  
 PLUG: PPS GF40 (BLACK)  
 SEAL/GROMMET: VMQ (RED-ORANGE)  
 CLIP: STEEL, UNPLATED  
 BOLD: STAINLESS STEEL WITH SILVER PLATING AND MAY TARNISH.

- 4. MATING TORQUE REQUIREMENT: 25-28 in-lb (2.82-3.16 Nm).
- 3. THIS PLUG MATES WITH DRC10-40P-XXXX; DRC12-40PXE-XXXX; DRC13-40PX-XXXX; DRC14-40PXE-XXXX. CONSULT FACTORY FOR MODIFICATIONS. X = A, B, C, D KEYS, XXXX = MODIFICATIONS
- 2. FOR CONTACTS AND WIRE PERFORMANCE AND APPLICATION CHARACTERISTICS, SEE ENVELOPE DRAWING 0425-015-0000.
- 1. PLUG IS SUPPLIED WITH DUST CAP, 0515-001-4005 (NOT SHOWN)

NOTES:

THIS DRAWING IS A CONTROLLED DOCUMENT.		DWN J. APOSTOL 18JUL2000				
DIMENSIONS: INCHES [mm]		CHK B. BYFORD 15APR2002				
TOLERANCES UNLESS OTHERWISE SPECIFIED:		APVD R. REED 15APR2002				
0 PLC ± 1 PLC ± 2 PLC ± 3 PLC ±.025 [.635] 4 PLC ± ANGLES ±0° 30' 0"		PRODUCT SPEC -				
MATERIAL 5		FINISH -	NAME DRC CONNECTOR PLUG 40 CONTACTS REDUCED E WIRE SEAL			
		WEIGHT -	SIZE A3	CAGE CODE 4AFU8	DRAWING NO. DRC16-40SE	RESTRICTED TO -
CUSTOMER DRAWING			SCALE 1.5:1	SHEET 1 OF 1	REV C	