

FURUNO Multi-GNSS Disciplined Oscillator

GF-880x Series Evaluation Kit

Models **VF-81, VF-82, VF-83,
VF-84, VF-85**

User's Guide

(Document No. SE19-900-016-00)



FURUNO ELECTRIC CO., LTD.

www.furuno.com

IMPORTANT NOTICE

No part of this manual may be reproduced or transmitted in any form or by any means, electronic or mechanical, including photocopying and recording, for any purpose without the express written permission of the publisher, FURUNO ELECTRIC CO., LTD.
FURUNO ELECTRIC CO., LTD. All rights reserved.

FURUNO ELECTRIC CO., LTD. reserves the right to make changes to its products and specifications without notice.

In this product, FURUNO can ensure safe performance only the commands and the sentences which are written in this document or are written in the document for this product. Please do not use the commands of the others products, otherwise this product may have troubles and FURUNO may not support about the troubles.

FURUNO may inform some internal commands for verification etc. In this case, please use the commands only for operation test and please do not use them for technical operation.

All brand and product names are registered trademarks, trademarks or service marks of their respective holders.

The following satellite systems are operated and controlled by the authorities of each government.

- GPS(USA)
- GLONASS (Russia)
- Galileo (Europe)
- QZSS(Japan)
- SBAS(USA: WAAS, Europe: EGNOS, Japan: MSAS)

FURUNO is not liable for any degradation while using these satellite systems. FURUNO cannot guarantee specifications if any of these systems experience degradation. Based on these conditions the user is expected to be familiar with these systems and is fully responsible for their use.

Revision History

Version	Changed contents	Date
0	Initial release	2019.0524

Table of Contents

1	Outline	1
2	Component List	1
3	Overview of Evaluation Platform	2
4	General Connection Diagram	5
5	I/O Signal Description	6
6	Electrical Specifications	8
6.1	Absolute Maximum Rating	8
6.2	Power Supply	8
6.3	DC Characteristics	8
7	Environmental Specifications	9
8	RF Specifications (RF_COAX)	9
8.1	Recommended Antenna Specifications	9
8.2	Antenna Amplifier Power	9
9	Receiver Status Signal Specifications	10
9.1	Alarm Signal (ALM_N)	10
9.2	Lock Signal (LOCK)	10
10	Restriction of Power ON/OFF Sequence between VCC12 and USB	11
11	Monitoring Software	11
11.1	Installation	11
11.2	Operation	11
12	Schematics	12
12.1	VF-01/02/03	12
12.2	VF-04/05	16
13	Special Attention	19
13.1	Precaution for Users	19
14	Contact Information	20

1 Outline

This documents describe the operation guides one of which is for the GF-8801/02/03 receivers and the other for the GF-8804/05 receivers.

- VF-81/82/83: GF-8801/02/03 evaluation platform
- VF-84/85: GF-8804/05 evaluation platform

2 Component List

- a. Evaluation platform
- b. AU-18: GNSS Antenna
- c. Conversion cable
- d. USB cable
- e. CD-ROM
 - GNSS Conductor GF monitoring software
 - GNSS Conductor GF User's Guide
 - GF-880x series Hardware Specifications
 - GF-880x series Protocol Specifications
 - This document

3 Overview of Evaluation Platform

Figure 3.1 shows an overview of VF-81/82/83.

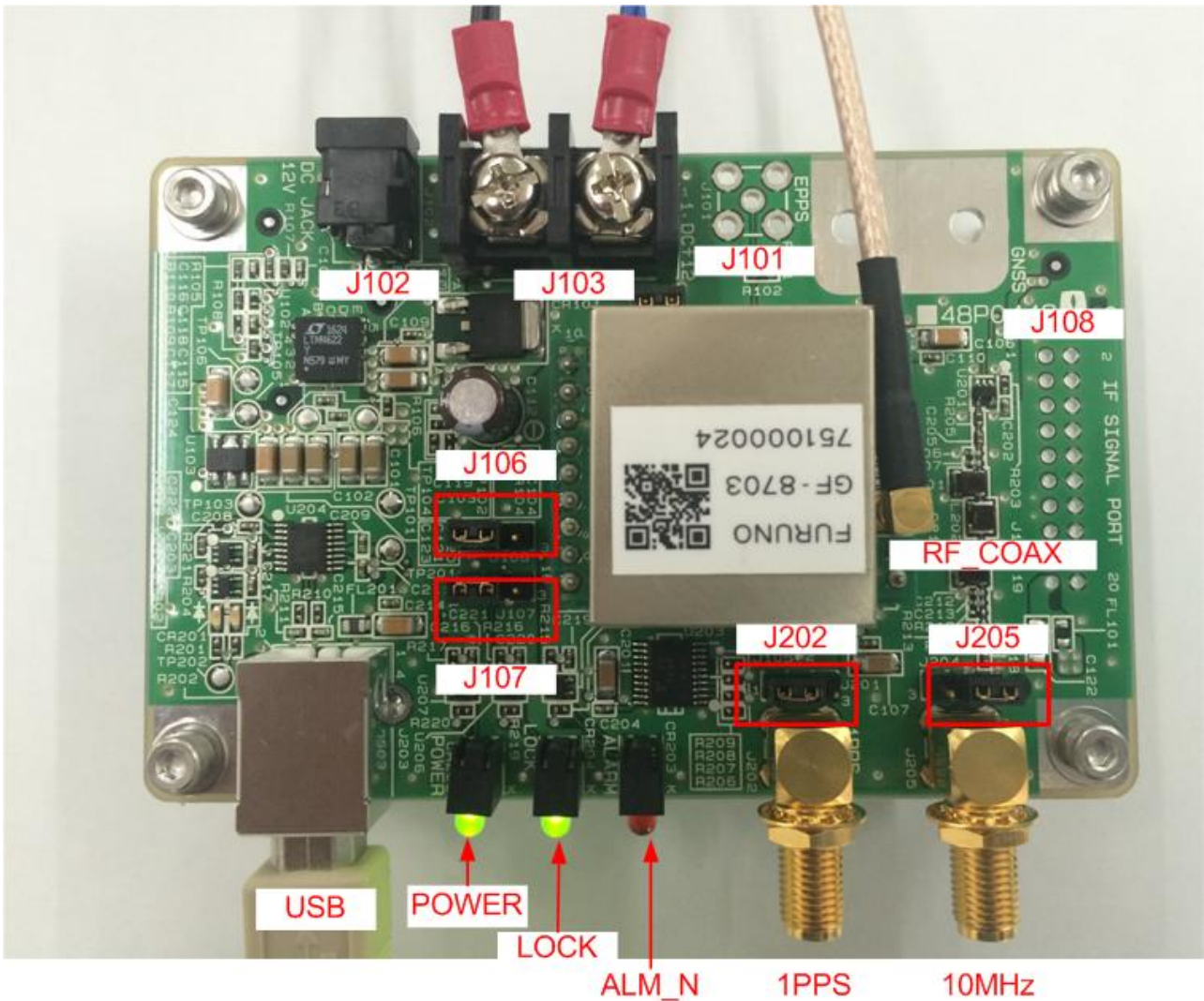

Figure 3.1 Overview of VF-81/82/83

Figure 3.2 and Figure 3.3 show overviews of VF-84/85.

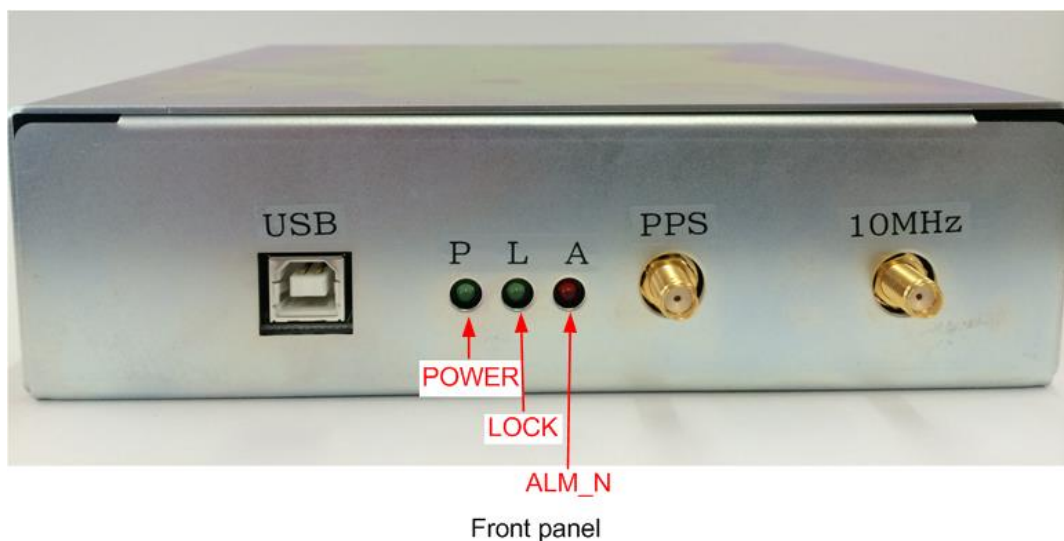

Figure 3.2 Outside Overview of VF-84/85

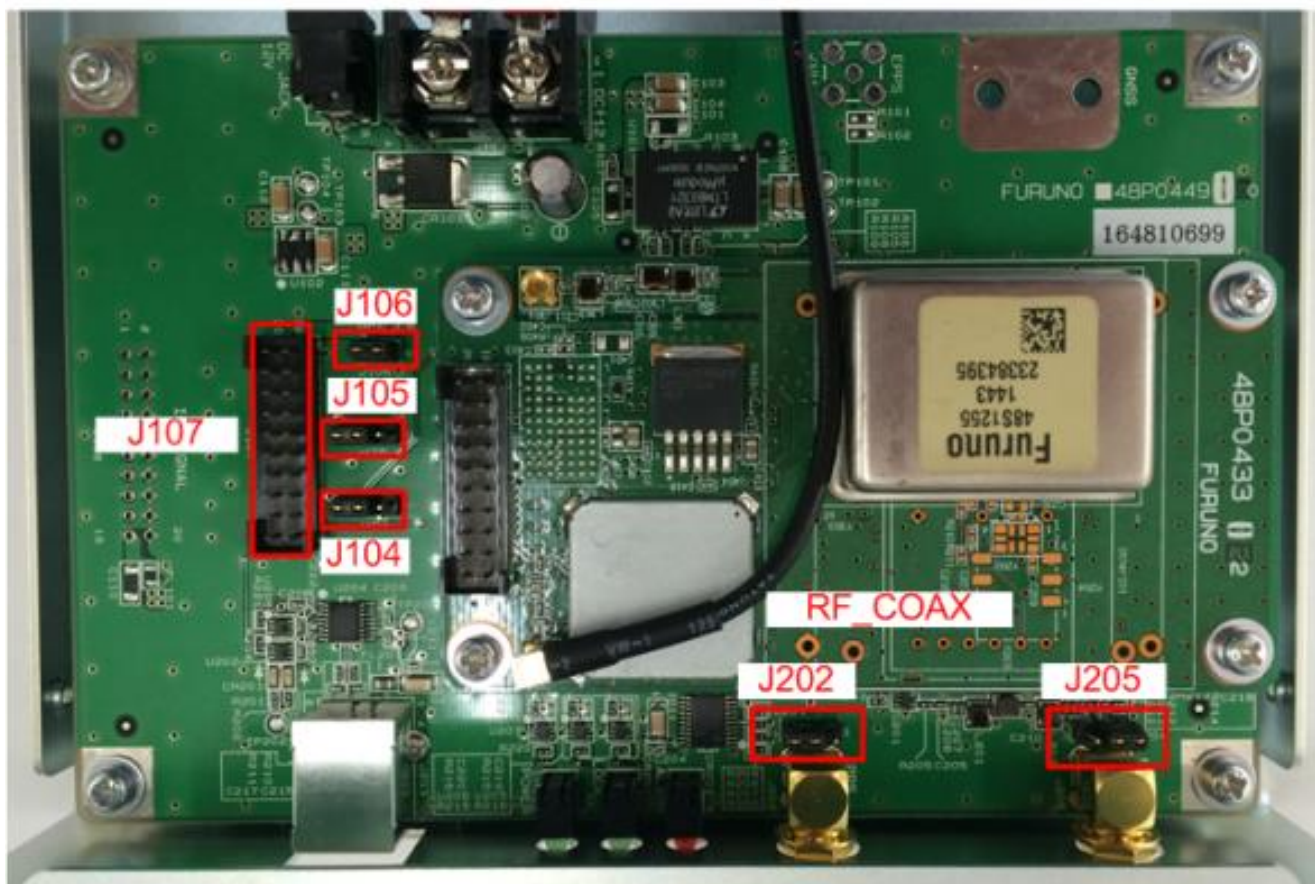

Figure 3.3 Inside Overview of VF-84/85

4 General Connection Diagram

Figure 4.1 shows a general connection diagram of VF-81/82/83.

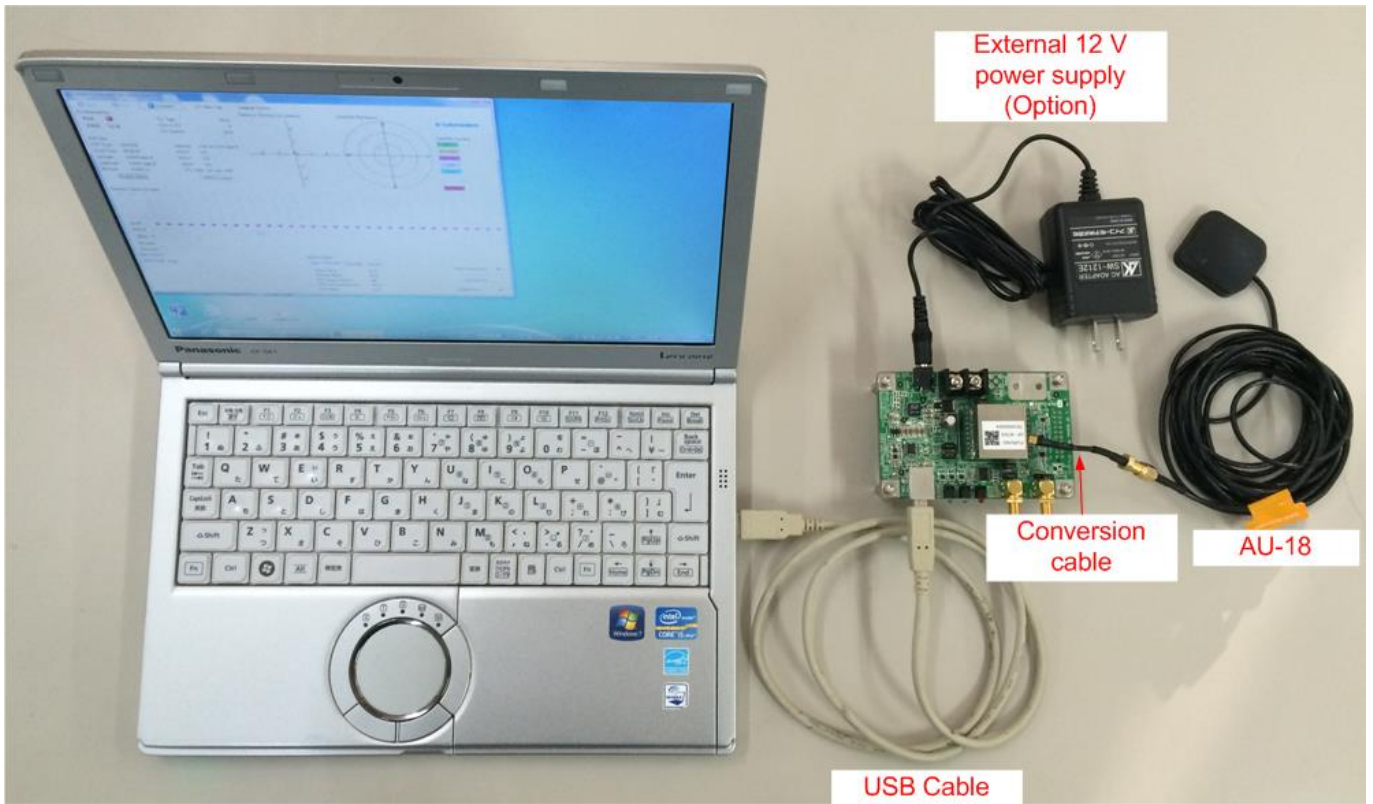

Figure 4.1 Overview of General Connection Diagram of GF-880x Series Evaluation Platform

5 I/O Signal Description

Table 5.1 and Table 5.2 show the I/O signal description of GF-880x series evaluation platform.

Table 5.1 I/O Signal Description of VF-81/82/83

Signal name	Connector #	Pin#	Connector	Jumper configuration	Default	I/O	Description
VCC12	J102	P	EIAJ RC5320A TYPE4	-	-	I	DC 12V
	J103	1	BP101-2PN10			I	
EPPS	J101	1	Not implemented	J107 2-1	●	I	External PPS input with 50Ω termination
		17	Pin Number: 1-20 Pin Pitch: 2.54mm	J107 2-3	-	I	External PPS input with CMOS 3.3V level
GF_RST_N	1	-		-	I	External reset signal	
GF_VCLK	3	-		-	O	Rectangular waveform 10MHz	
GF_RXD	5	J106 2-1		●	I	USB	
		J106 2-3			I		
GF_TXD	7	-		-	O	UART TX	
GF_ALM_N	9	-		-	O	Alarm status H: Normal L: Failed	
GF_LOCK	11	-		-	O	Lock status H: Lock L: Unlock	
GF_GLK	13	-		-	O	Programmable clock output signal Frequency range is from 4kHz to 40MHz.	
GF_PPS	15	-		-	O	PPS output signal	
GND	2,4,8,10,12,14,16,18-20	-	-	-	-	Signal ground	
10MHz	J205	1	SMA	J204 2-1	●	O	50Ω sine wave
				J204 2-3	-	O	CMOS 3.3V rectangular wave
PPS	J202	1	SMA	J201 2-1	●	O	3.3V PPS at 50Ω termination
				J201 2-3	-	O	CMOS 3.3V PPS

Table 5.2 I/O Signal Description of VF-84/85

Signal name	Connector #	Pin#	Connector	Jumper configuration	Default	I/O	Description	
VCC12	J103	1	BP101-2PN10	-	-	I	DC 12V	
EPPS	J101	1	Not implemented	J104 2-1	●	I	External PPS input with 50Ω termination	
		2		J104 2-3	-	I	External PPS input with CMOS 3.3V level	
GF_RST_N	J107 ¹⁾	1	Pin Number: 1-20 Pin Pitch: 2.54mm	-	-	I	External reset signal	
GF_VCLK		16		-	-	O	Rectangular waveform 10MHz	
GF_RXD		14		J105 2-1	●	I	USB	
GF_TXD		12		J105 2-3	-	I	CMOS 3.3V RX	
GF_ALM_N		10		-	-	O	Alarm status H: Normal L: Failed	
GF_LOCK		8		-	-	O	Lock status H: Lock L: Unlock	
GF_GLK		6		-	-	O	Programmable clock output signal Frequency range is from 4kHz to 40MHz.	
GF_PPS		4		-	-	O	PPS output signal	
GND		5,7,9 13,18,20		-	-	-	-	Signal ground
10MHz		J205		1	SMA	J204 2-1	●	O
	J204 2-3		-			O	CMOS 3.3V rectangular wave	
PPS	J202	1	SMA	J201 2-1	●	O	3.3V PPS at 50Ω termination	
				J201 2-3	-	O	CMOS 3.3V PPS	

Notes:

1) J107 is connected to J108 in GF-8804 or 8805.

6 Electrical Specifications

6.1 Absolute Maximum Rating

Table 6.1 shows the absolute maximum rating of GF-880x series evaluation platform.

Table 6.1 Absolute Maximum Rating

Items	Symbol	Min.	Max.	Unit	Notes
12V Supply voltage	V_{CC_ABS}	-0.3	22	V	
Digital input (DI) voltage	V_{DI_ABS}	-0.5	6.5	V	
Digital output (DO) voltage	V_{DO_ABS1}	-0.5	6.5	V	Condition: VCC=0
	V_{DO_ABS2}	-0.5	3.8	V	Condition: VCC=normal voltage
Digital output (DO) current	I_{DO_ABS}	-	±50	mA	
VCC_RF output current	$I_{CC_RF_ABS}$	-	75	mA	
RF_IN input power	P_{RFIN_ABS}	-	-5	dBm	at 1575.42MHz & 1602MHz
		-	0	dBm	at 900MHz
		-	-1	dBm	at 1800MHz

6.2 Power Supply

Table 6.2 shows the power supply range of VCC as main voltage at GF-880x series evaluation platform.

Table 6.2 Power Supply Range of VCC

$T_A=25^\circ\text{C}$, unless otherwise stated

Items	Condition	Symbol	Min.	Typ.	Max.	Unit	Notes
Supply voltage to VCC	-	V_{CC}	10.5	12	13.5	V	
VCC current consumption	GF-8801	I_{CCAL01}	-	-	100	mA	VF-01/02/03
	GF-8802	I_{CCAL02}	-	-	500	mA	
	GF-8803	I_{CCAL03}	-	-	800	mA	
	GF-8804	I_{CCAL04}	-	-	850	mA	VF-04/05
	GF-8805	I_{CCAL05}	-	-	850	mA	
Antenna power supply voltage	$I_{ANT}=75\text{mA}(\text{Max})$	V_{ANT}	4.5	5	-	V	

6.3 DC Characteristics

Table 6.3 shows the DC characteristics of digital I/O port at GF-880x series evaluation platform.

Table 6.3 DC Characteristics of Digital I/O Port

Items	Condition	Symbol	Min.	Typ.	Max.	Unit	Notes
Low level input voltage	-	V_{IL}	-	-	0.8	V	
High level input voltage	-	V_{IH}	2.0	3.3	5.5	V	
1PPS Low level output voltage	$I_{OL}=16\text{mA}(\text{Max})$	V_{OL}	-	-	0.4	V	J201 2-3
VCLK Low level output voltage	$I_{OL}=16\text{mA}(\text{Max})$	V_{OL}	-	-	0.4	V	J204 2-3
1PPS High level output voltage	$I_{OH}=-18\text{mA}(\text{Max})$	V_{OH}	2.4	3.3	3.6	V	J201 2-3
VCLK High level output voltage	$I_{OH}=-18\text{mA}(\text{Max})$	V_{OH}	2.4	3.3	3.6	V	J204 2-3
Input pull-down resistance	-	R_{PD}	-	10	-	kΩ	
Input pull-up resistance	-	R_{PU}	-	10	-	kΩ	
Input pull-up voltage	-	V_{PU}	-	3.3	-	V	

7 Environmental Specifications

Table 7.1 shows the environmental specifications of GF-880x series evaluation platform.

Table 7.1 Environmental Specifications

Items	Specifications	unit	Notes
Operating Temperature	0 to +45	°C	
Storage temperature	-40 to +85	°C	
Operation humidity	85 (MAX)	%R.H	T _A = 60 °C, No condensation

8 RF Specifications (RF_COAX)

8.1 Recommended Antenna Specifications

Please refer to “10.7 Recommended GNSS Antenna” at Hardware Specifications of GF-8801/02/03 and GF-8804/05.

8.2 Antenna Amplifier Power

Please refer to “10.8 Antenna Amplifier Power” at Hardware Specifications of GF-8801/02/03 and GF-8804/05.

9 Receiver Status Signal Specifications

9.1 Alarm Signal (ALM_N)

Table 9.1 shows the relation between the alarm status and the configuration of LED. The user can check the alarm field in CRZ(TPS4)²⁾ sentence with this table.

Table 9.1 Relation between Alarm Status and Configuration of LED

Status of alarm field at CRZ(TPS4)	ALM_N	Red LED	Description
00	Logic H	Light-out	Normal
Except 00	Logic L	Lighting	Abnormal

Notes:

- 2) Please refer to “6.13 CRZ (TPS4) - **VCLK Frequency and Control**” at Protocol Specifications of GF-8801/02/03 and GF-8804/05.

9.2 Lock Signal (LOCK)

Table 9.2 shows the relation between the lock status and the configuration of LED. The user can check the frequency mode field in CRZ(TPS4)³⁾ sentence with this table. The user can set the output condition of LOCK signal with the Lock port set field in MODESET command.

Table 9.2 Relation between Lock Status and Configuration of LED

MODESET lock port set	Status of frequency mode field at CRZ(TPS4)	LOCK	LED
0	2,3,4	Logic H	Lighting
	Except the above mode	Logic L	Light-out
1 (default)	2,3	Logic H	Lighting
	Except the above mode	Logic L	Light-out
2	3	Logic H	Lighting
	Except the above mode	Logic L	Light-out
3	3,4	Logic H	Lighting
	Except the above mode	Logic L	Light-out

Notes:

- 3) Please refer to “6.13 CRZ (TPS4) - **VCLK Frequency and Control**” at Protocol Specifications of GF-8801/02/03 and GF-8804/05.

10 Restriction of Power ON/OFF Sequence between VCC12 and USB

Please keep the following power on/off sequence specifications between VCC12 and USB power.

In case the user does not follow the below specification, the PC may not be able to read correct identification from USB interface device in evaluation kit. This is due to the fact that the identification data in memory of the USB interface device is erased which is caused by unstable power supply voltage.

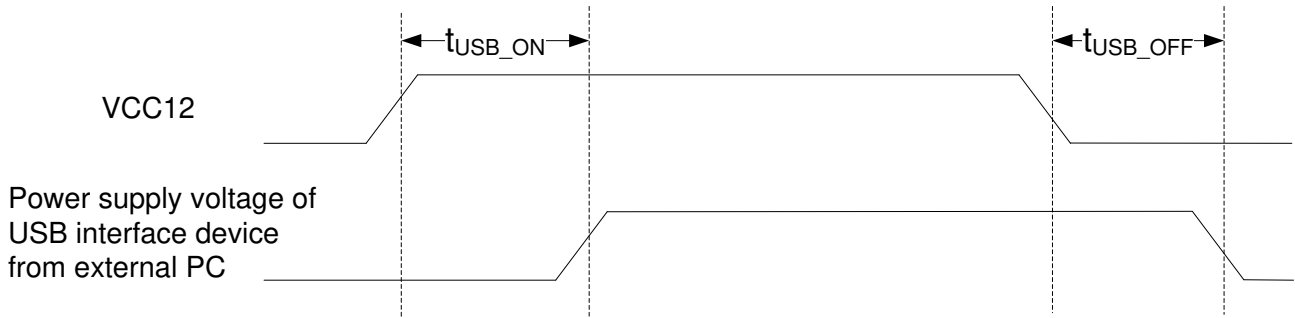

Figure 10.1 Power On/Off Sequence Specifications between VCC12 and USB Power

Table 10.1 Specifications of t_{USB_OFF} and t_{USB_ON}

Items	Symbol	Min.	Max.	Unit
Necessary low level time of USB power after VCC12 is high level	t_{USB_OFF}	0	-	sec
Necessary high level time of USB power after VCC12 is low level	t_{USB_ON}	2	-	sec

11 Monitoring Software

11.1 Installation

Please refer to “GNSS Conductor GF User’s Guide (SE16-900-008)”.

11.2 Operation

Please refer to “GNSS Conductor GF User’s Guide (SE16-900-008)”.

12 Schematics

12.1 VF-81/82/83

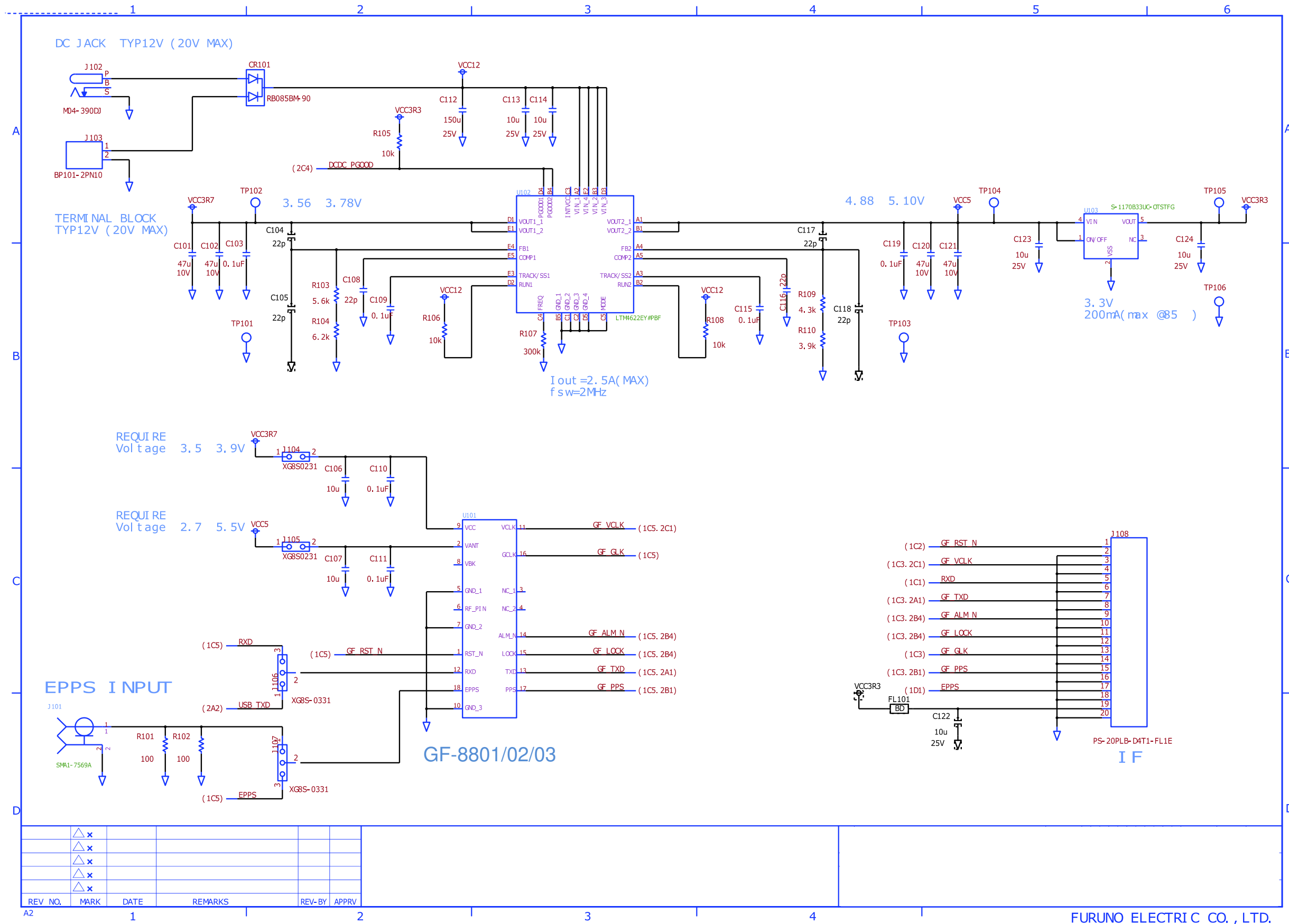

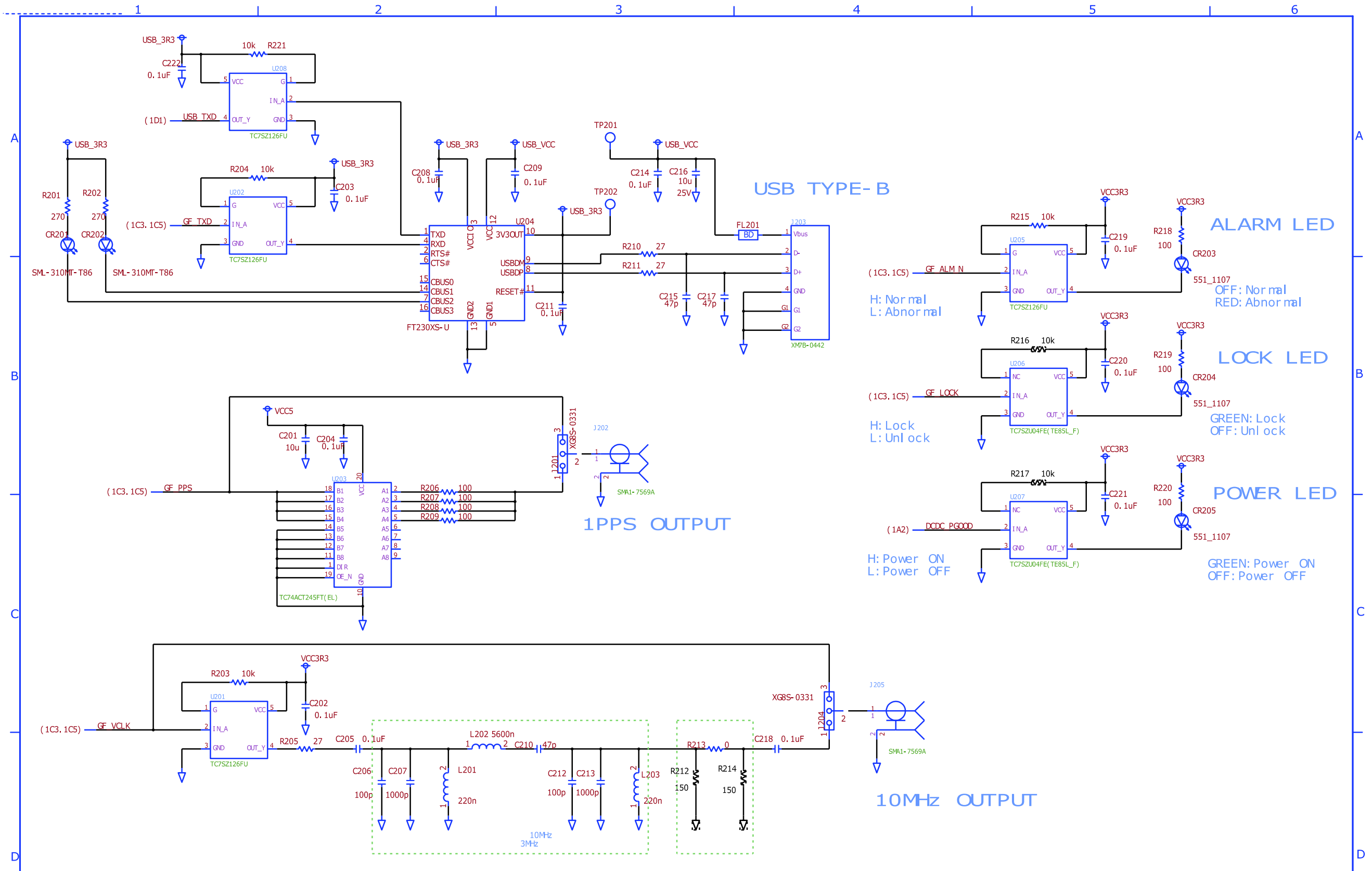

△ x					
△ x					
△ x					
△ x					
△ x					
REV. NO.	MARK	DATE	REMARKS	REV-BY	APPRV

Component #	Products #	Vender
C101,C102,C120,C121	GRM31CR61A476ME15L	Murata
C103,C109,C110,C111,C115,C119,C202,C203,C204,C205,C208,C209,C211,C214,C214,C218,C219,C220,C221,C222	GRM155R11C104KA88D	Murata
C104,C105,C108,C116,C117,C118	GRM1552C1H220JA01D	Murata
C106,C107,C113,C114,C122,C123,C124,C201,C216	GRM31CR71E106KA12L	Murata
C112	EKZN250ETD151MF11D	Nichikemi
C206,C212	GRM1552C1H101JA01D	Murata
C207,C213	GRM1552C1H102JA01D	Murata
C210,C215,C217	GRM1552C1H470JA01D	Murata
CR101	RB085BM-90	Rohm
CR201,CR202	SML-310MT-T86	Rohm
CR203,CR204,CR205	551_1107	dialight
FL101,FL201	MPZ2012S601AT000	TDK
J101	SMA1-7569A	Connect
J102	M04-390DJ	Marushin
J103	BP101-2PN10	IDEC
J104,J105	XG8S0231	Omron
J106,J107,J201,J204	XG8S-0331	Omron
J108	PS-20PLB-D4T1-FL1E	JAE
J202	SMA1-7569A	Connect
J203	XM7B-0442	Omron
J205	SMA1-7569A	Connect
L201	KQ1008TTER22G	KOA
L202	KQ1008TTE5R6G	KOA
L203	KQ1008TTER22G	KOA
R101,R102	MCR03EZPJ101	Rohm
R103	MCR01MZPD5601	Rohm
R104	MCR01MZPD6201	Rohm
R105,R106,R108,R203,R204,R215,R216,R217,R221	MCR01MZPJ103	Rohm
R107	MCR01MZPJ304	Rohm
R109	MCR01MZPD4301	Rohm
R110	MCR01MZPD3901	Rohm
R201,R202	MCR01MZPJ271	Rohm
R205,R210,R211	MCR01MZPJ270	Rohm
R206,R207,R208,R209,R218,R219,R220	MCR01MZPJ101	Rohm
R212,R214	MCR01MZPJ151	Rohm
R213	MCR01MZPJ000	Rohm
U101	GF-8701/GF-8702/GF8703	FURUNO
U102	LTM4622EY#PBF	LT
U103	S-1170B33UC-OTSTFG	SII
U201,U202,U205,U208	TC7SZ126FU	Toshiba
U203	TC74ACT245FT(EL)	Toshiba
U204	FT230XS-U	FTDI
U206,U207	TC7SZ04FU(TE85L_JF)	Toshiba

<Power supply electric characteristics>

$T_A=25^{\circ}\text{C}$, unless otherwise stated

Symbol	Description	Unit	Min	Typ	Max
V_{IN}	Input voltage	V	3.6	-	20
V_{OUT}	Output voltage	V	3.56	-	3.78
I_{OUT}	Output current	A	-	-	2.5
f_{SW}	Switching frequency	MHz	-	2	-

<Band pass filter characteristics>

-Filter Type: 3rd Butterworth filter

-Cutoff Frequency : 3MHz

-Input/Output Impedance : 50Ω

Figure 12.1 shows a filter characteristics simulation result of 3rd Butterworth filter in the schematics.

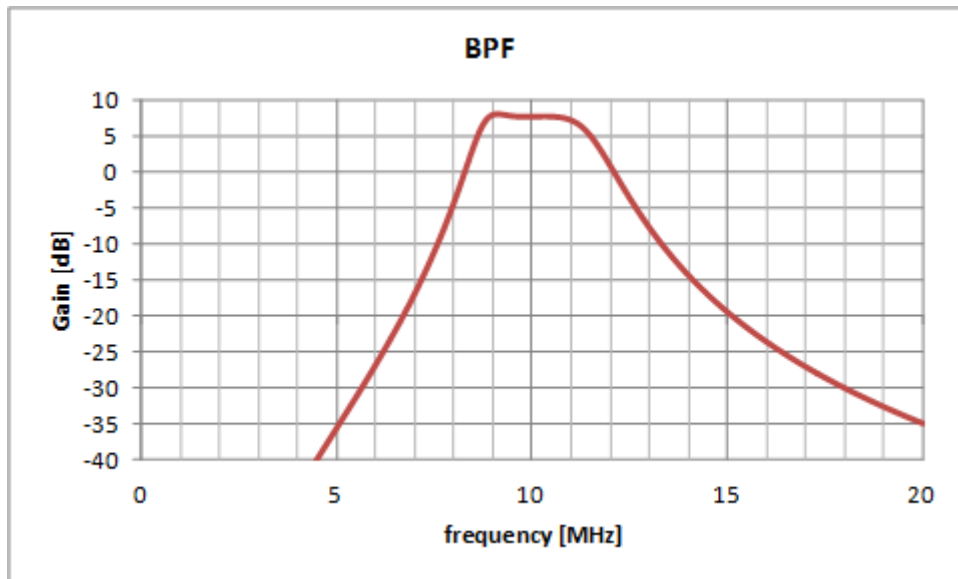
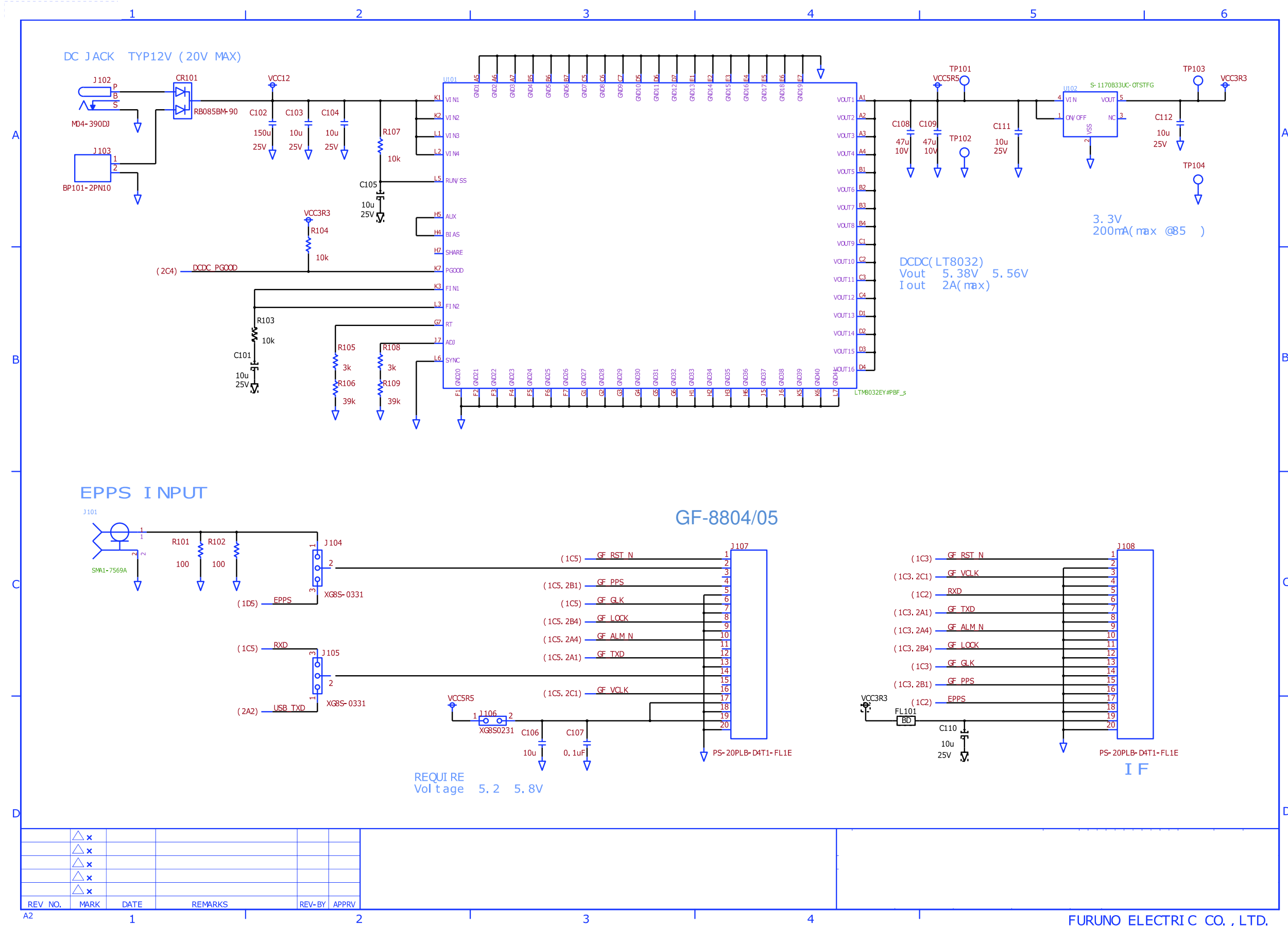
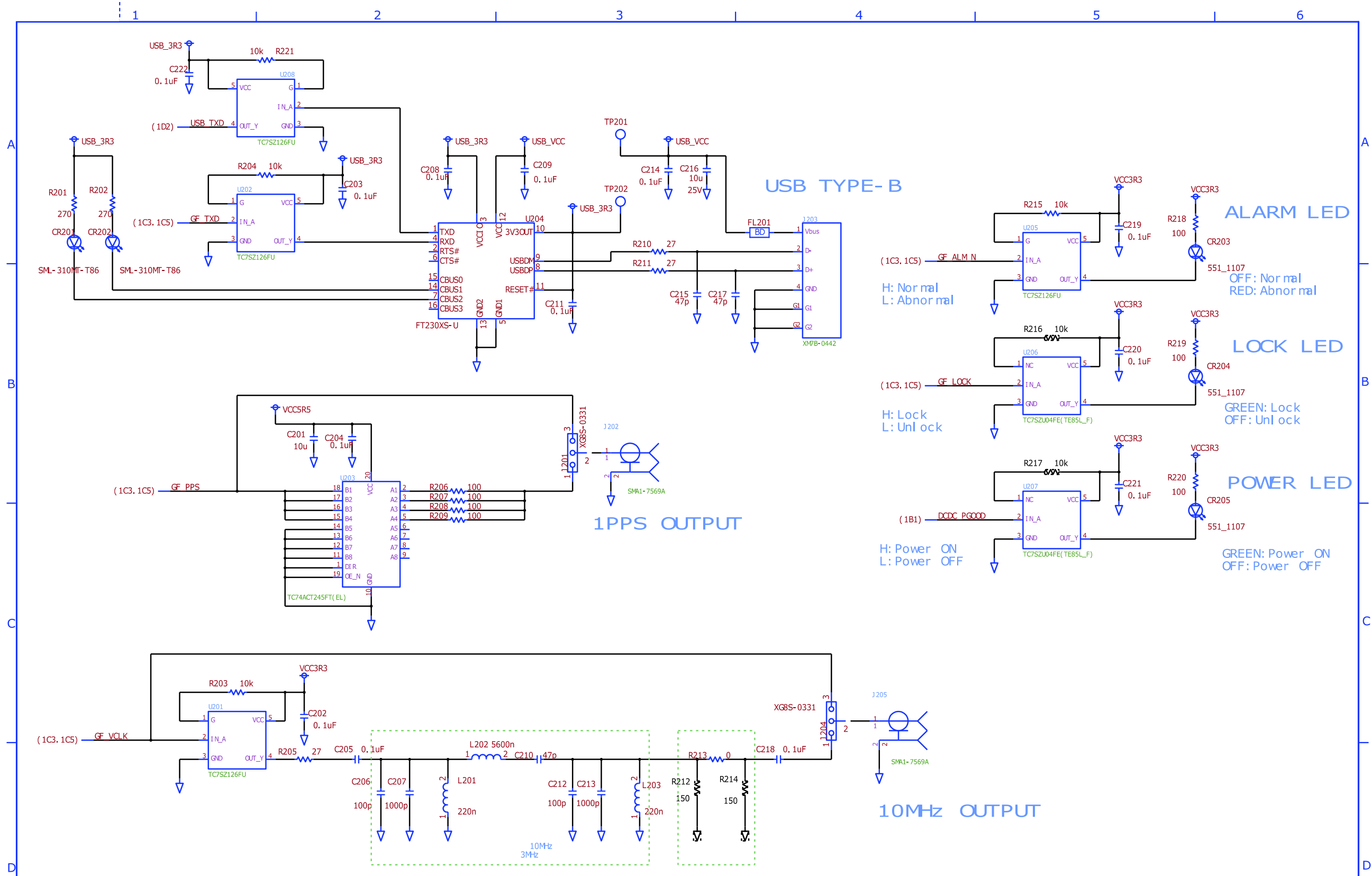

Figure 12.1 Simulation Results of 3rd Butterworth Filter

12.2 VF-84/85





△ x					
△ x					
△ x					
△ x					
△ x					
REV. NO.	MARK	DATE	REMARKS	REV-BY	APPRV

Component #	Products #	Vender
C101,C103,C104,C105,C106,C110,C111,C112,C201,C216	GRM31CR71E106KA12L	Murata
C102	EKZN250ETD151MF11D	Nichikemi
C107,C202,C203,C204,C205,C208,C209,C211,C214,C218,C219,C220,C221,C222	GRM155R11C104KA88D	Murata
C108,C109	GRM31CR61A476ME15L	Murata
C206,C212	GRM1552C1H101JA01D	Murata
C207,C213	GRM1552C1H102JA01D	Murata
C210,C215,C217	GRM1552C1H470JA01D	Murata
CR101	RB085BM-90	Rohm
CR201,CR202	SML-310MT-T86	Rohm
CR203	551_1107	dialight
CR204	551_1107	dialight
CR205	551_1107	dialight
FL101,FL201	MPZ2012S601AT000	TDK
J101,J202,J205	SMA1-7569A	Connect
J102	M04-390DJ	Marushin
J103	BP101-2PN10	IDEC
J104,J105,J201,J204	XG8S-0331	Omron
J106	XG8S0231	Omron
J107,J108	PS-20PLB-D4T1-FL1E	JAE
J203	XM7B-0442	Omron
L201,L203	KQ1008TTER22G	KOA
L202	KQ1008TTE5R6G	KOA
R101,R102	MCR03EZPJ101	Rohm
R103,R104,R107,R203,R204,R215,R216,R217,R221	MCR01MZPJ103	Rohm
R105,R108	MCR01MZPD3001	Rohm
R106,R109	MCR01MZPD3902	Rohm
R201,R202	MCR01MZPJ271	Rohm
R205,R210,R211	MCR01MZPJ270	Rohm
R206,R207,R208,R209,R218,R219,R220	MCR01MZPJ101	Rohm
R212,R214	MCR01MZPJ151	Rohm
R213	MCR01MZPJ000	Rohm
U101	LTM8032EY#PBF_s	LT
U102	S-1170B33UC-OTSTFG	SII
U201,U202,U205,U208	TC7SZ126FU	Toshiba
U203	TC74ACT245FT(EL)	Toshiba
U204	FT230XS-U	FTDI
U206,U207	TC7SZ04FU(TE85L_JF)	Toshiba

<Power supply electric characteristics>

T_A=25°C, unless otherwise stated

Symbol	Description	Unit	Min	Typ	Max
V _{IN}	Input voltage	V	-	12	
V _{OUT}	Output voltage	V	5.38	-	5.56
I _{OUT}	Output current	A	-	-	2
f _{SW}	Switching frequency	MHz	-	2	-

<Notification>

Please note that those schematics in this documents are only samples on which FURUNO has designed this product and are provided to users as a reference for further development at each user-end.

FURUNO shall NOT indemnify and hold the users harmless from any loss, damage, or liability for direct/indirect infringement of any third party's patent or copyright arising from the usage of any of the schematics in this document.

FURUNO SHALL NOT BE UNDER ANY LIABILITY TO USERS IN RESPECT OF THE SCHEMATISC IN THIS DOCUMENT, WITHOUT LIMITATION ANY PRODUCT LIABILITY.

Thus FURUNO is not liable for the degradation by their operating so that FURUNO cannot guarantee specification based on this condition. User is expected to be familiar with the System and make full use of it with their responsibility.

13 Special Attention

13.1 Precaution for Users

- (1) A GNSS receiver receives very weak signals sent by the GNSS satellites. Using an antenna with band limitations or insufficient preamplifier could be disrupted by transmitted power from TV broadcast, mobile phone, MCA or similar transmitting devices causing unstable reception status. Therefore use an antenna equipped with a SAW filter on the preamplifier front stage to ensure stable GNSS reception.
- (2) It is recommended to install the antenna vertically outdoors in a location where there are no obstacles within its elevation angle of 5°. GNSS signals may reflect from buildings, trees or ground surfaces and reach a GNSS antenna via the reflected (delayed) route. Therefore install a GNSS antenna in environment where there are no reflected waves. Therefore avoid mounting near buildings or other obstructions.
- (3) Radio waves transmitted by handheld transmitters or transmitting antennas may adversely affect GNSS signal reception by superimposing interfering signal onto the GNSS antenna. When locating the GNSS antenna ensure is not located in the direction of offending transmitting antenna beam.
- (4) RF noise may interfere via the GNSS antenna and adversely affect the GNSS signal reception. Avoid using GNSS devices near equipment emitting RF noise.
- (5) Considering the information above check tracking status of the GNSS satellites and positioning information. Possibly for an extended period of time (8 to 24 hours) to ensure no multipath signal or other reception issues exist. Also check the overall environment where the GNSS antenna will be located.
- (6) Ensure a stable power supply connection.
- (7) Install in a stable temperature, wind free environment for the GNSS unit to eliminate errors caused by temperature deviations.
- (8) Improper heat dissipation may increase the device temperature beyond the upper limit specifications resulting in performance degradation or failure. Install the device allowing sufficient space around the device for heat dissipation considerations.
- (9) Lightning may strike the GNSS antenna. This product does not have a lightning protector so we recommend inserting an appropriate arrester between the GNSS antenna and this product.

14 Contact Information

FURUNO ELECTRIC CO., LTD
2-20 Nishinomiya-Hama
Nishinomiya, Japan
Tel: +81-798-33-9588

FURUNO U.S.A., Inc.
GPS/OEM Timing Division
70 Engerman Avenue
Denton, MD 21629
Tel: +1 (410) 479-4420
Fax: +1 (410) 479-4429
gpssales@furuno.com