

THIS DRAWING IS UNPUBLISHED. RELEASED FOR PUBLICATION
 © COPYRIGHT BY TYCO ELECTRONICS CORPORATION. ALL RIGHTS RESERVED.

LOC	DIST	REVISIONS					
		P	LTR	DESCRIPTION	DATE	DWN	APVD
G	14		B	REDRAWN PER 60720-0540-95	24AUG04	JR	TM

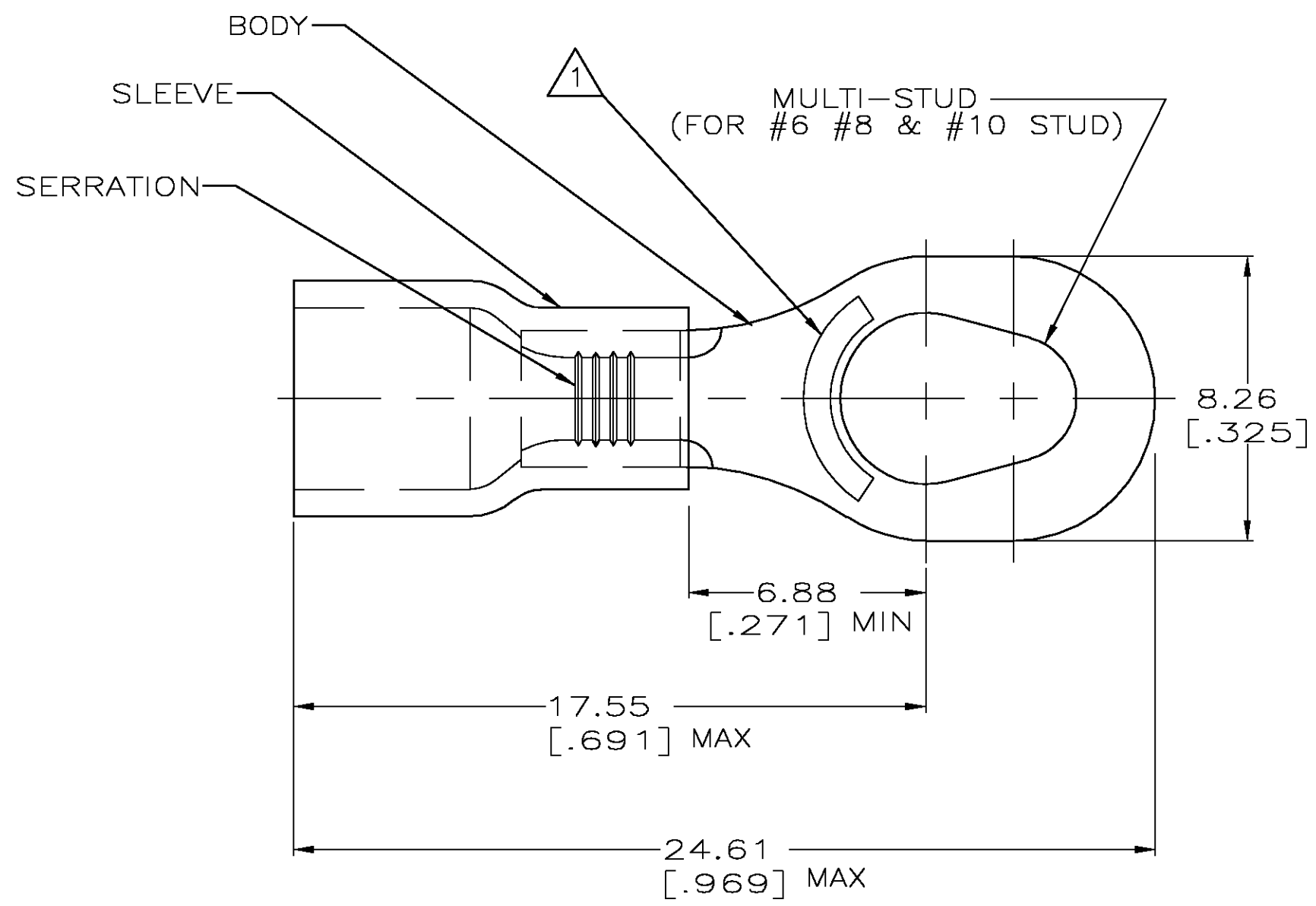

AMP WIRE RANGE	Listed FILE E13288	LR7189 Certified
22-16 AWG SOLID OR STRANDED	22-16 AWG SOLID OR STRANDED	22-16 AWG SOLID OR STRANDED

- 1 STAMP AMP 22-18* 1-2 APPROX AS SHOWN
22-16 TERMINALS ARE STAMPED 22-18 IN
ACCORDANCE WITH MILITARY SPEC MIL-T-7928
COMMERCIAL WIRE RANGE IS 22-16
- 2. WIRE INSUL DIA, 2.03-3.18 [.080-.125]
- 3. TONGUE MATL THK, 0.79±0.05 [.031±.002]
- 4 MATERIAL: BODY - CU PER ASTM B152
SLEEVE - PVC, COLOR - RED

-	-	-
5000	ON TAPE, REEL	54774-2
1000	LOOSE PIECE	54774-1
QTY	PACKAGE TYPE	PART NO

AMP INCORPORATED CUSTOMER SERVICE SYSTEMS		MAX RECOMMENDED OPERATING TEMPERATURE: 105°C [221°F]	THIS DRAWING IS A CONTROLLED DOCUMENT.		DWN L OLMEDA 05SEP95	Tyco Electronics Corporation Harrisburg, Pa 17105-3608	
FOR ADDITIONAL PRODUCT INFORMATION OR COPIES OF DRAWINGS AND TECHNICAL DOCUMENTS	PRODUCT INFORMATION CENTER 1-800-522-6752	VOLTAGE RATING: 600V MAX (1000V FIXTURE OR SIGN)	DIMENSIONS: mm [INCHES]	TOLERANCES UNLESS OTHERWISE SPECIFIED:	CHK M ELLIS 05SEP95	NAME TERMINAL, RING, MULTI-STUD, PLASTI-GRIP WIRE SIZE: 22-16	
FOR APPLICATION TOOLING INFORMATION	TOOLING ASSISTANCE CENTER 1-800-722-1111	CIRCULAR MIL AREA: 0.26-1.65mm² [509-3260] SOLID OR STRANDED		0 PLC ± - 1 PLC ± - 2 PLC ± 0.20 [.008] 3 PLC ± - 4 PLC ± - ANGLES ± -	APVD G NGO 05SEP95	PRODUCT SPEC UL 486A	SIZE A3
FOR ORDER ENTRY	1-800-526-5142	THIS DRAWING IS A CONTROLLED DOCUMENT FOR AMP INCORPORATED. IT IS SUBJECT TO CHANGE AND THE CONTROLLING ENGINEERING ORGANIZATION SHOULD BE CONTACTED FOR THE LATEST REVISION.	MATERIAL -4	FINISH TIN PER ASTM B545	APPLICATION SPEC -	WEIGHT -	CAGE CODE 00779
					DRAWING NO C-54774		RESTRICTED TO -
					CUSTOMER DRAWING		SCALE 6:1
							SHEET 1 OF 1
							REV B