

| LOC | | DIST | | REVISIONS | | | |
|-----|-----|---------------|---------|-----------|------|--|--|
| P | LTR | DESCRIPTION | DATE | DWN | APVD | | |
| B | | ECO-07-026027 | 12NOV07 | LAM | PR | | |

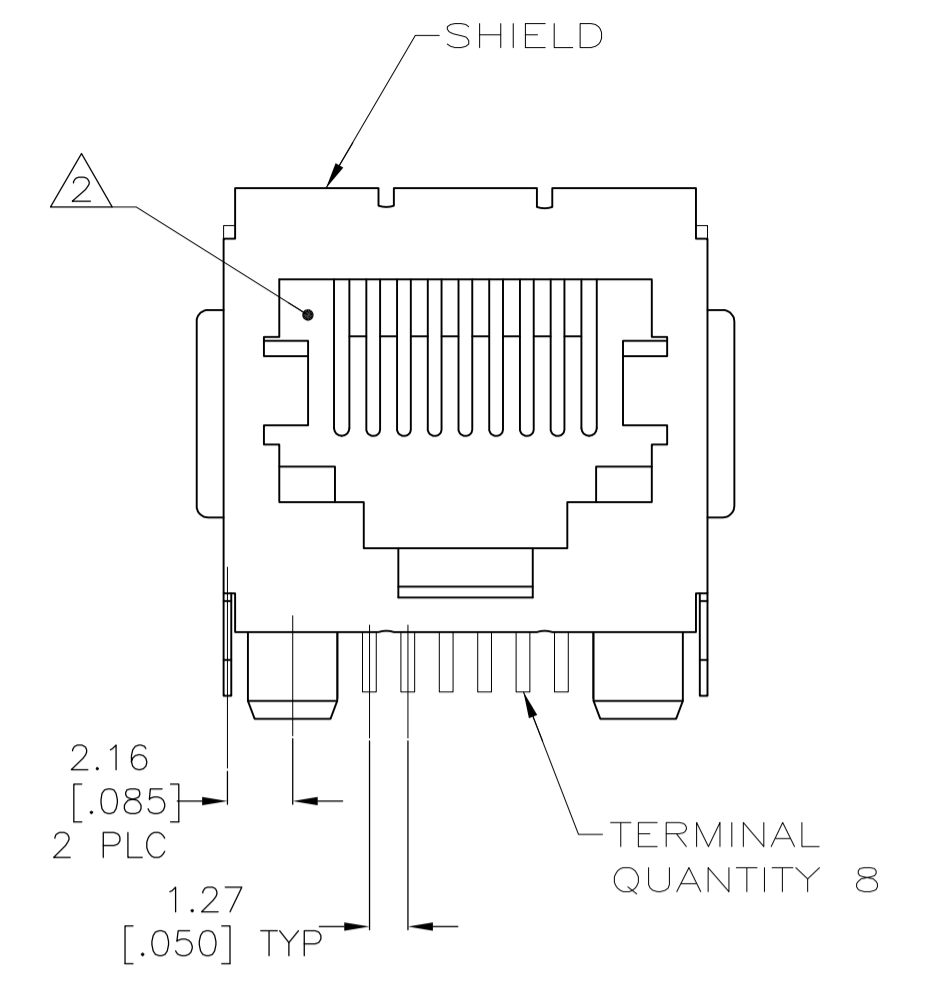
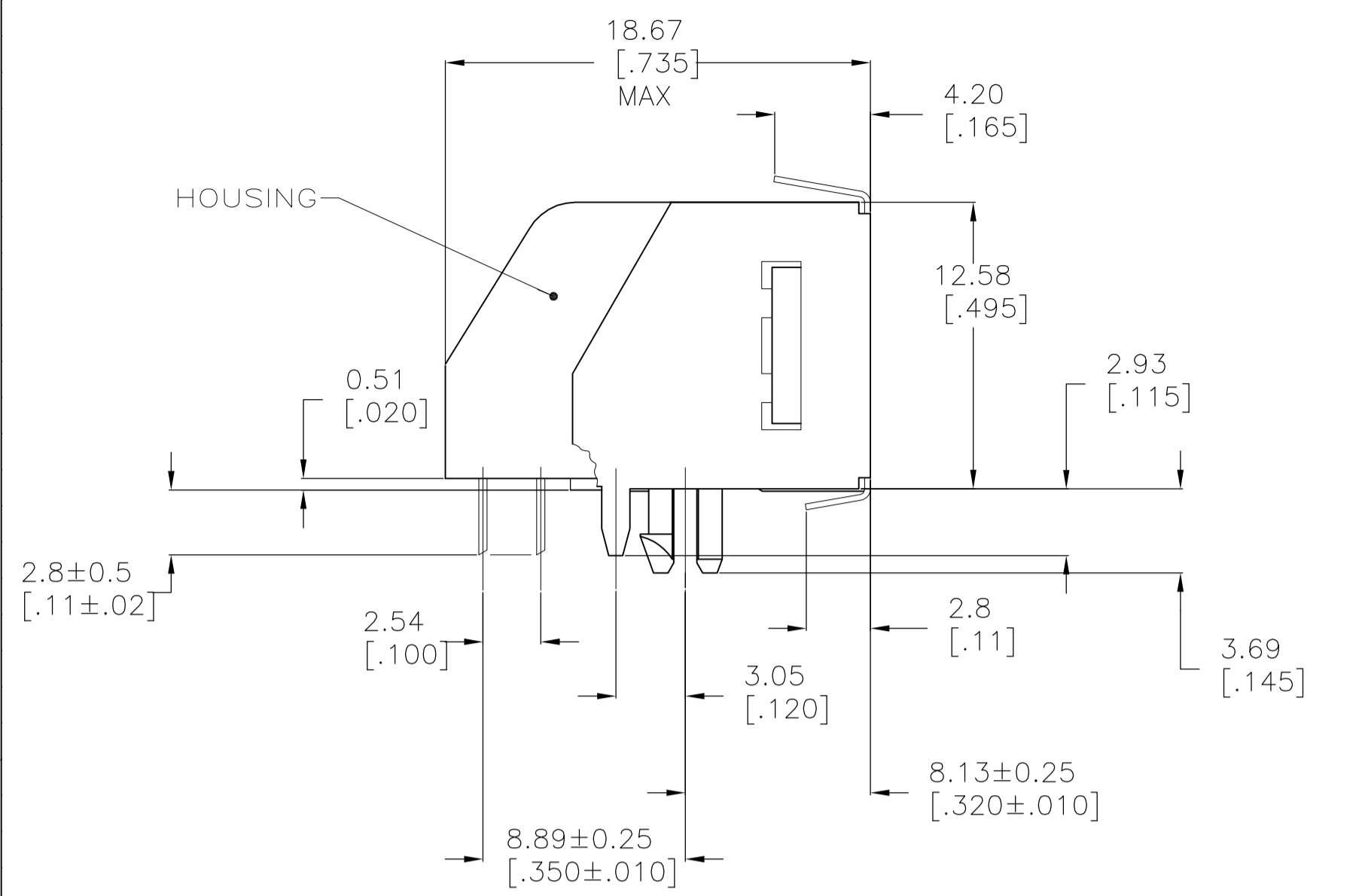

- MATERIAL:
 HOUSING - HTN NYLON MOLDING COMPOUND, 94 VO, COLOR: BLACK
 TERMINAL - 0.36[.014] THICK PHOS-BRONZE
 PLATED WITH 1.27μm[.000050] MINIMUM THICK HARD GOLD IN LOCALIZED GOLD PLATE AREA AND 3.81μm[.000150] MINIMUM THICK MATTE TIN IN SOLDER AREA OVER 1.27μm[.000050] THICK MINIMUM NICKEL UNDERPLATE.
 SHIELD - 0.25[.010] THICK COPPER ALLOY PLATED WITH 3.0μm[.000120] MINIMUM REFLOWED TIN

2 CAVITY CONFORMS TO FCC RULES AND REGULATIONS, PART 68, SUBPART F

3 DIMENSION MEASURED ALONG FRONT EDGES OF MATING FACE

4 PACKAGED 31 ASSEMBLIES PER TUBE WITH BOTH ENDS PLUGGED (SEE DETAIL A)

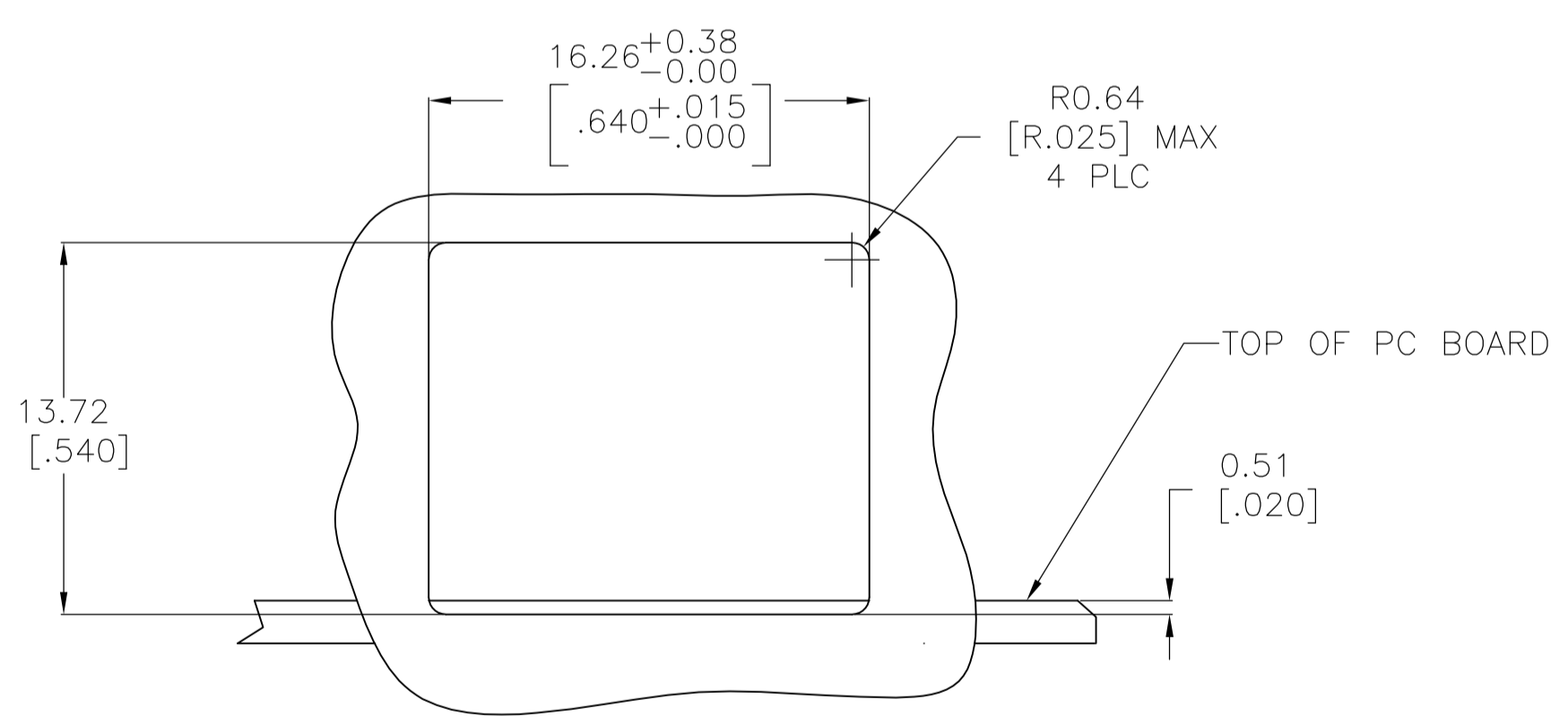
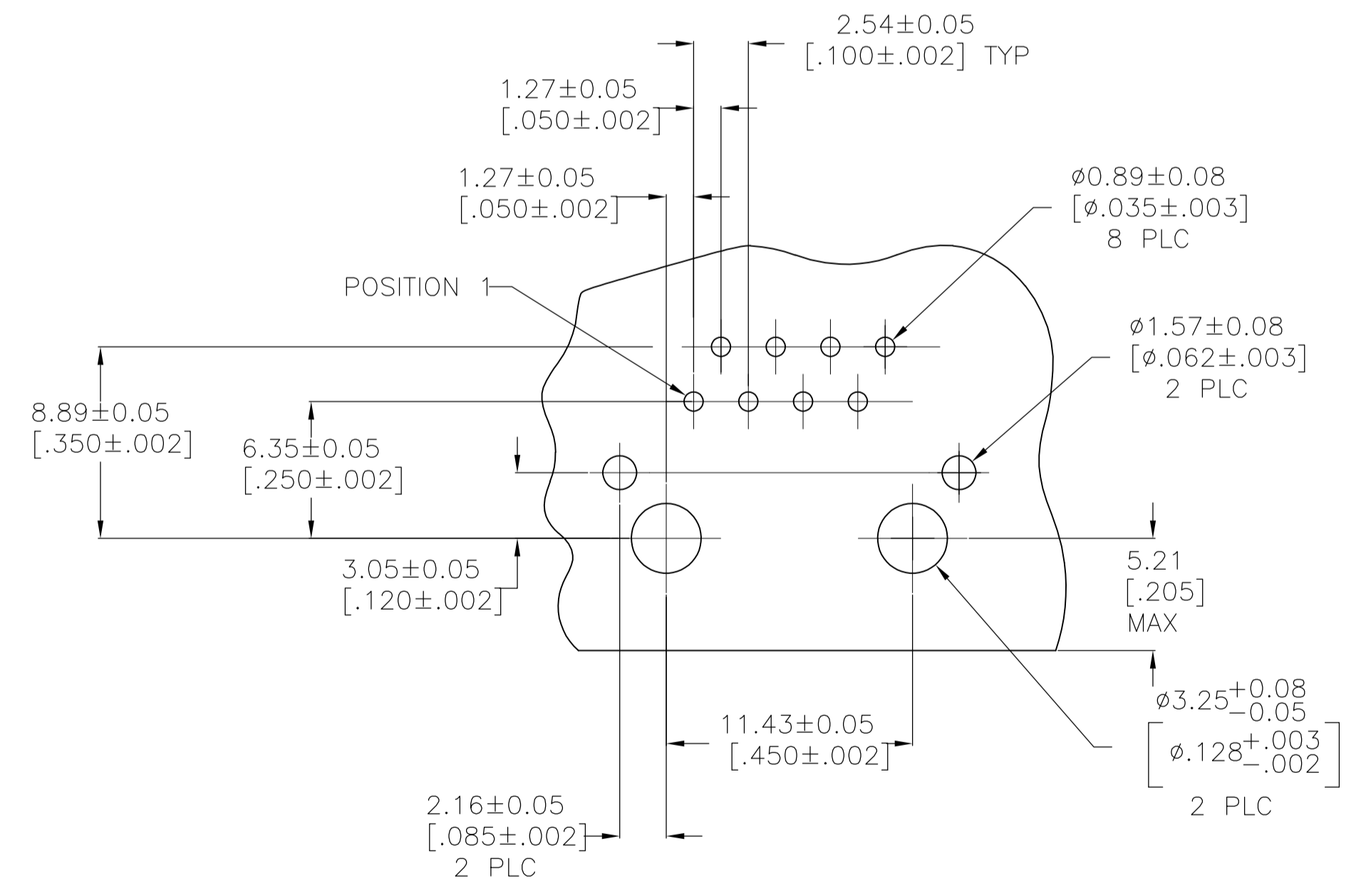
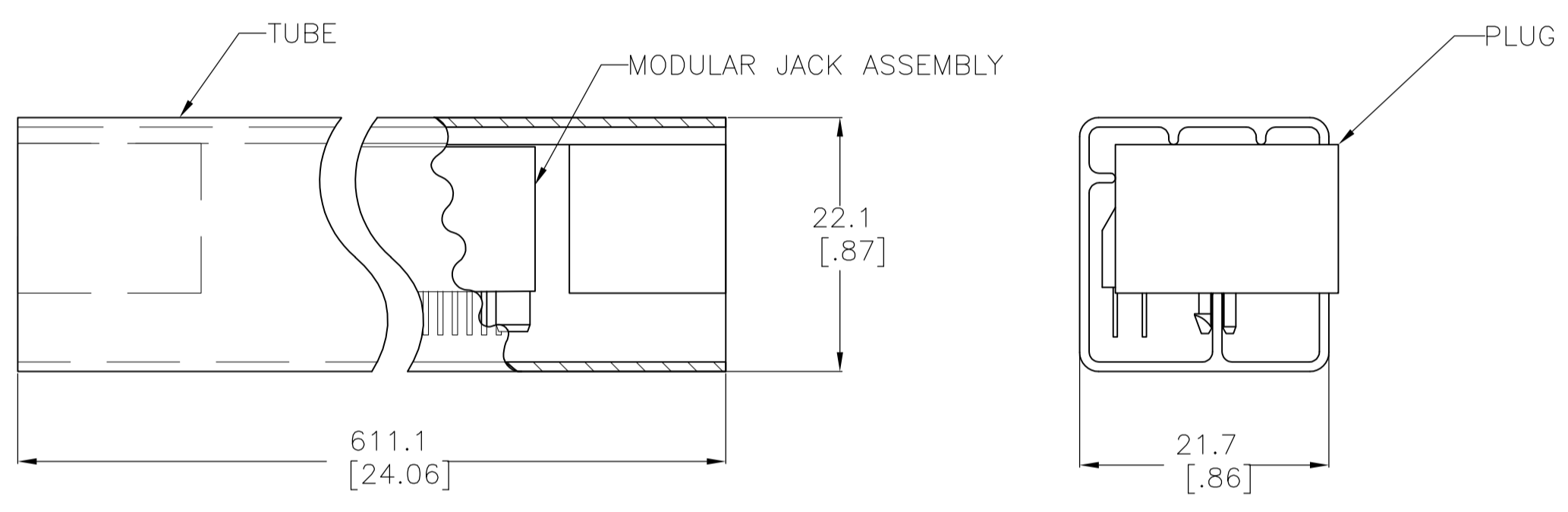
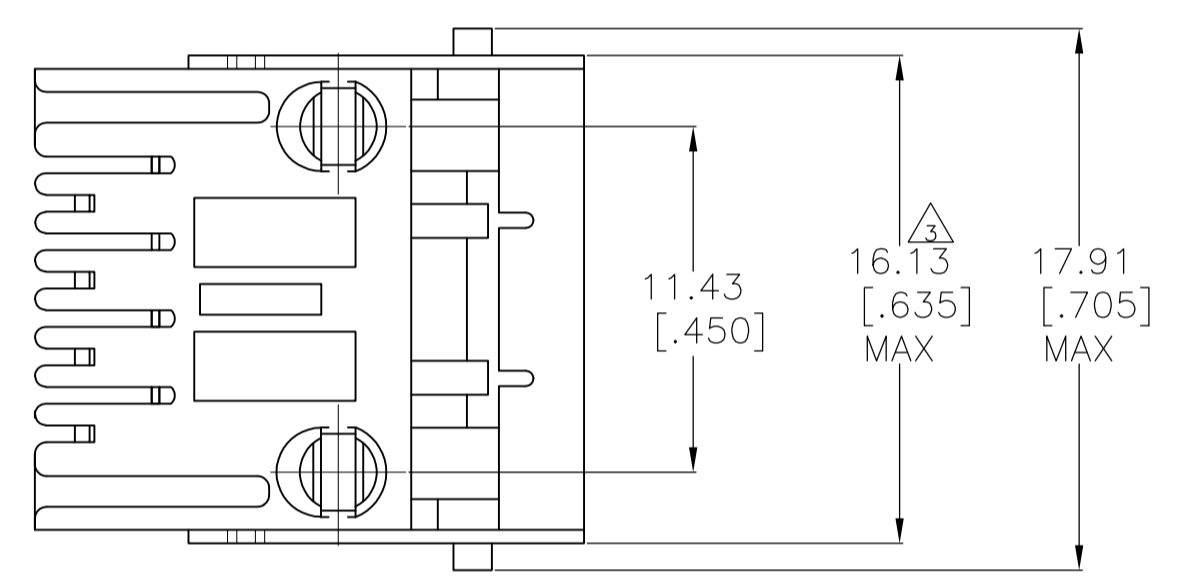

RECOMMENDED PRINTED CIRCUIT BOARD LAYOUT (COMPONENT SIDE)

RECOMMENDED PANEL CUTOUT

5569115-1
 PART NUMBER

| | | | | |
|--|--|---------------------------|--|------------------------------|
| THIS DRAWING IS A CONTROLLED DOCUMENT. | | DIN L.A.MAYER 04APR2005 | Tyco Electronics Corporation Harrisburg, PA 17105-3608 | |
| DIMENSIONS: mm [INCHES] | | CHK J.WESTMAN 04APR05 | NAME S.FLICKINGER 04APR05 | |
| TOLERANCES UNLESS OTHERWISE SPECIFIED: | | PRODUCT SPEC 108-1163 | | |
| 0 PLC ± - | | APPLICATION SPEC 114-2048 | | |
| 1 PLC ± - | | SIZE A1 | | |
| 2 PLC ± ± 0.13[.005] | | CAGE CODE 00779 | | |
| 3 PLC ± ± - | | DRAWING NO 5569115 | | |
| 4 PLC ± ± - | | RESTRICTED TO | | |
| ANGLES ± ± - | | CUSTOMER DRAWING | | |
| MATERIAL SEE NOTE 1 | | FINISH SEE NOTE 1 | | SCALE 4:1 SHEET 1 OF 1 REV B |