

61082- AA B C D E W G V FF

V	MANDATORY CODE
/	STANDARD, NOT MANDATORY P/N
V	ONLY FOR DEDICATED CUSTOMER
H	ONLY FOR DEDICATED CUSTOMER
L	ONLY FOR DEDICATED CUSTOMER

G	DATE CODE
/	NOT PRINT DATE CODE
P	PRINT DATE CODE

W	TRANSPORT CODE
/	NOT MANDATORY
W	FOR OCEAN SHIPPING

E	PACKAGING
0	TUBE WITHOUT METAL CAP
2	T&R WITH METAL CAP
9	TUBE WITH METAL CAP
6	T&R WITHOUT METAL CAP (WITH KAPTON TAPE)
Q	T&R WITHOUT CAP

NOTE 10  
NOTE 10

C	PLATING ON CONTACT AREA/ SOLDER TAIL	FF
0	GOLD 0.2um MIN / TIN LEAD	NONE
1	GOLD FLASH (0.065um MIN) OVER PALLADIUM-NICKEL 0.69um MIN / TIN LEAD	NONE
4	GOLD 0.2um MIN / PURE TIN 2um MIN (LEAD FREE)	LF
5	GOLD 0.38um MIN / PURE TIN 2um MIN (LEAD FREE)	LF
6	GOLD FLASH (0.065um MIN) OVER PALLADIUM-NICKEL 0.69um MIN / PURE TIN 2um MIN (LEAD FREE)	LF
7	GOLD 0.76um MIN / PURE TIN 2um MIN (LEAD FREE)	LF
B	GOLD 1.27um MIN / GOLD 0.05~0.25um (LEAD FREE)	LF
C	GOLD 1.27um MIN / PURE TIN 2um MIN (LEAD FREE)	LF
D	GOLD 0.38um MIN / GOLD FLASH (LEAD FREE)	LF

B		FOR PLUG, SEE DWG. NO. 61083			
COMBINATION OF MATED HEIGHT	Plug 1	Plug 2	Plug 3	Plug 4	
Recep 1					
Recep 2					
Recep 3					
Recep 4					

AA	POSITION
02	2X10
04	2X20
06	2X30
08	2X40
10	2X50
12	2X60
14	2X70
16	2X80
18	2X90
20	2X100

NOTE 10

POLARIZATION PEG		D
YES		0
NO		2

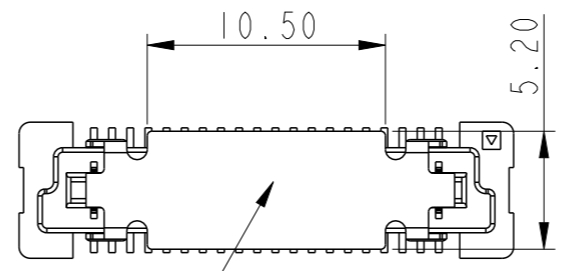

- NOTE:
- MATERIAL:  
HOUSING: G.F. LCP, NATURAL, UL94-V0  
TERMINAL: NICKEL COPPER
  - PLATING: AS SHOWN IN TABLE. NICKEL UNDERPLATE OVERALL 1.27um MIN.
  - SEE GS-12-547 FOR PRODUCT SPEC.
  - PACKAGING OPTION 2: NOT ALL SIZES ARE AVAILABLE. CHECK WITH FACTORY.
  - THIS PRODUCT MEETS THE EUROPEAN UNION DIRECTIVES AND OTHER COUNTRY REGULATIONS AS DESCRIBED IN GS-22-008.
  - THE HOUSING WILL WITHSTAND EXPOSURE UP TO 260~ PEAK TEMPERATURE FOR 30 SECONDS IN A CONVECTION, INFRA-RED OR VAPOR PHASE REFLOW OVEN.
  - PLATING OPTION "4" IS LEADFREE ALTERNATIVE FOR OPTION "0", AND OPTION "6" IS LEADFREE ALTERNATIVE FOR OPTION "1".
  - HIGH PRECISION COPLANARITY IS AVAILABLE FOR 2X80 TO 2X100 POS, ALL HEIGHTS. PLS REFER TO PRINT 10069525.
  - THE P/N 61082-\*\*\*\*\* OR 61082-\*\*\*\*\*LF NOT PRINT DATE CODE. THE P/N 61082-\*\*\*\*\*P OR 61082-\*\*\*\*\*PLF NEED PRINT DATE CODE.
  - PACKAGING WITH METAL CAP DOES NOT APPLY TO 2X10 POSITION.

spec ref	dr	Cheong, Matthe	2009/06/10	projection	MM	size	A3	scale	3:1
tolerance std	eng	Alan Ni	2022/11/03		← →	ecn no	ELX-N-46103-1	rel level	Released
ISO 406 ISO 1101	chr	-	-						
surface	appr	Tim Yao	2022/11/29	product family	-	rel level	Released		
linear	TOLERANCES UNLESS OTHERWISE SPECIFIED		0.X ±0.20	Amphenol FCI	title	BERGSTAK 0.8MM	dwg no	61082	rev
angular	0° ±2°	www.fci.com	cat. no.	-	Product - Customer Drw	sheet 1 of 7			AR

PRODUCT NO.	NUMBER OF POSITIONS	DIMENSION		
		A	B	C
61082-021***	2X10	7.2	13.8	12.2
61082-041***	2X20	15.2	21.8	20.2
61082-061***	2X30	23.2	29.8	28.2
61082-081***	2X40	31.2	37.8	36.2
61082-101***	2X50	39.2	45.8	44.2
61082-121***	2X60	47.2	53.8	52.2
61082-141***	2X70	55.2	61.8	60.2
61082-161***	2X80	63.2	69.8	68.2
61082-181***	2X90	71.2	77.8	76.2
61082-201***	2X100	79.2	85.8	84.2

DATE CODE: XXXXXX  
 DAY(01~31)  
 MONTH(01~12)  
 YEAR(00~99)

DETAIL F

COPLANARITY OF TAIL:  
 0.1 MAX. APPLIED TO 2X10 TO 2X70 POS.  
 0.13 MAX APPLIED TO 2X80 TO 2X100 POS.  
 HIGH PRECISION COPLANARITY IS AVAILABLE FOR 2X80 TO 2X100 POS.  
 PLS REFER TO PRINT 10069524.  
 DETAIL A  
 SCALE 10:1

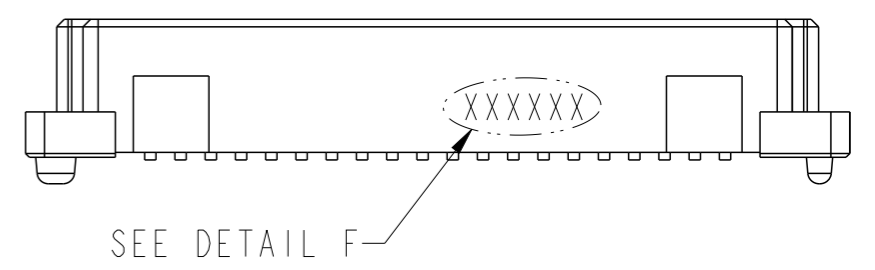
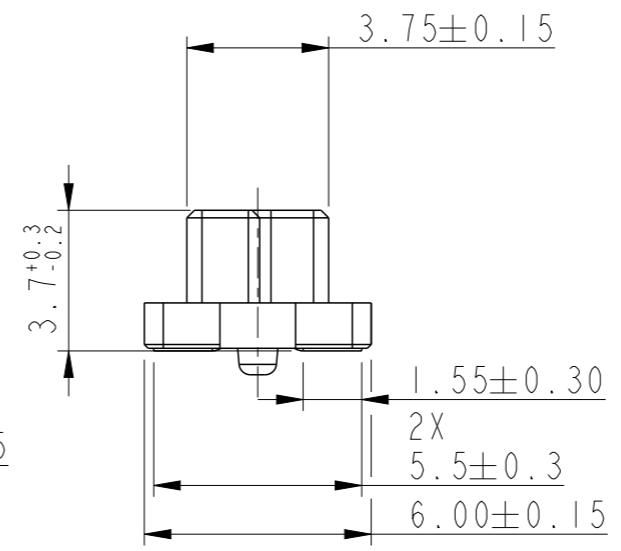
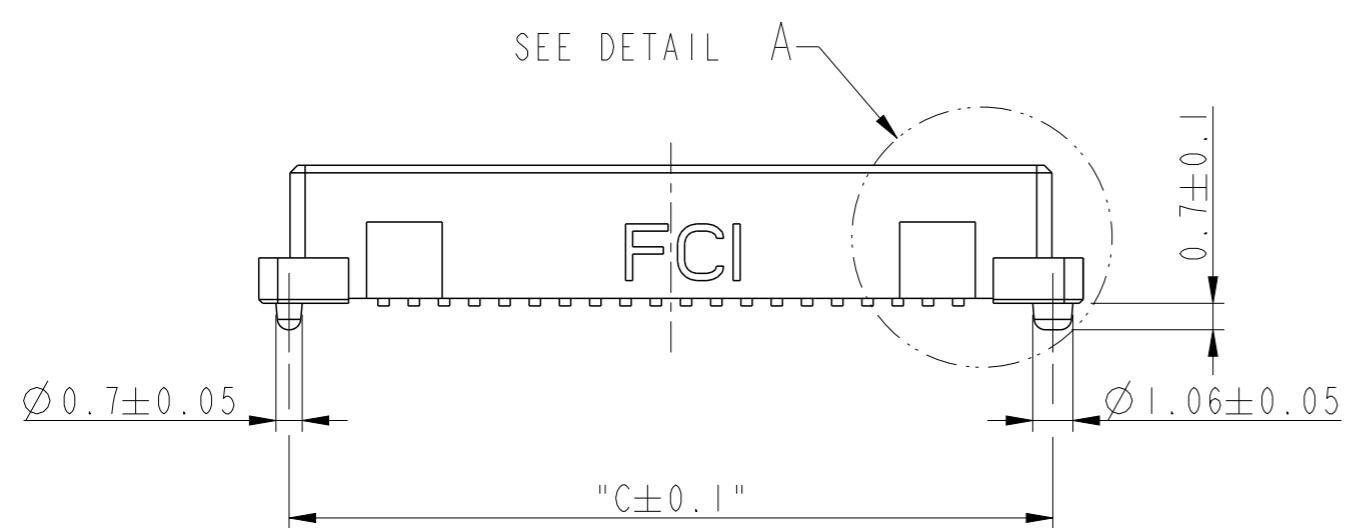
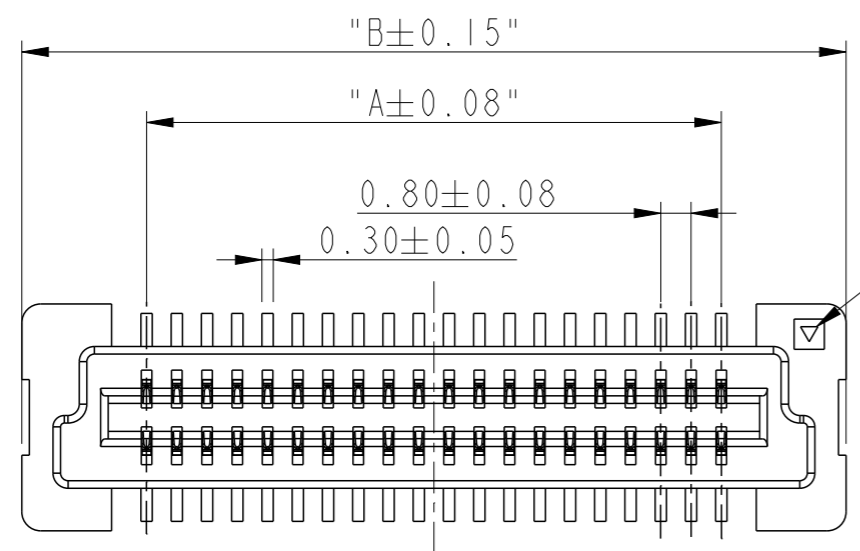

RECEPTACLE I

dr	Cheong, Matthe	2009/06/10	projection	MM	size	A3	scale	3:1
eng	Alan Ni	2022/11/03			ecn no ELX-N-46103-1			
chr	-	-			rel level Released			
appr	Tim Yao	2022/11/29	product family		-			
Amphenol FCI		BERGSTAK 0.8MM			dwg no		61082	
www.fci.com		RECEPTACLE ASS'Y			cat. no.		-	
		Product - Customer Drw			sheet 2 of 7		rev AR	

Creo File:ELX-WC-A3C.REV F.2020-12-21

RECEPTACLE 1

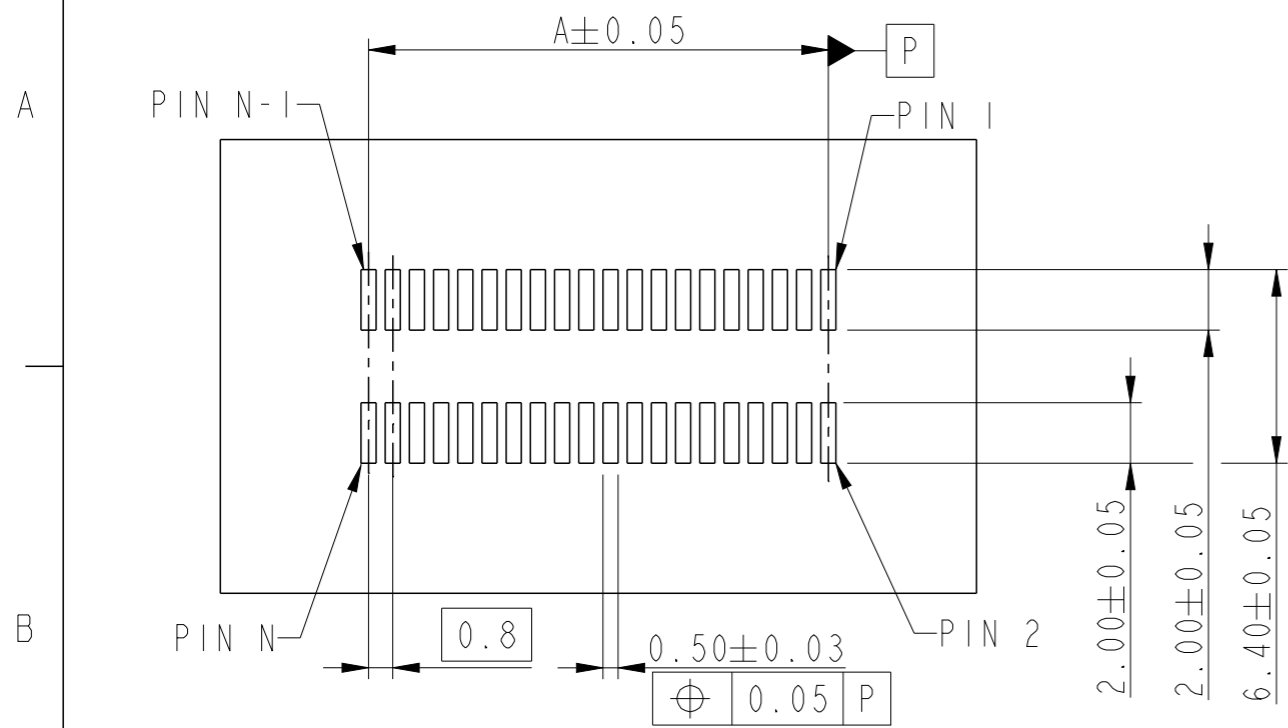

RECOMMENDED PCB LAYOUT WITHOUT PEGS

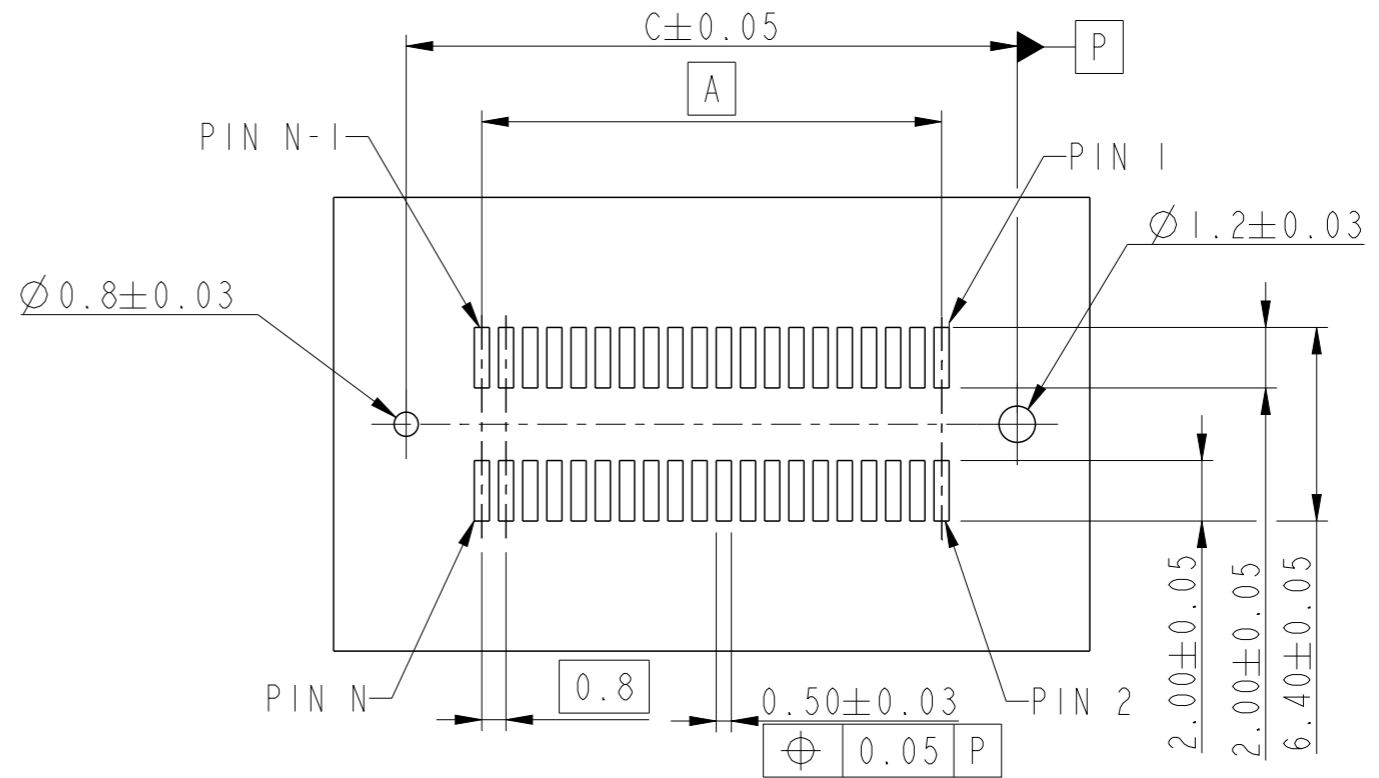

RECOMMENDED PCB LAYOUT WITH PEGS  
FOR NO. OF POSITION 2X10, 2X20, 2X30, 2X40, 2X50, 2X60

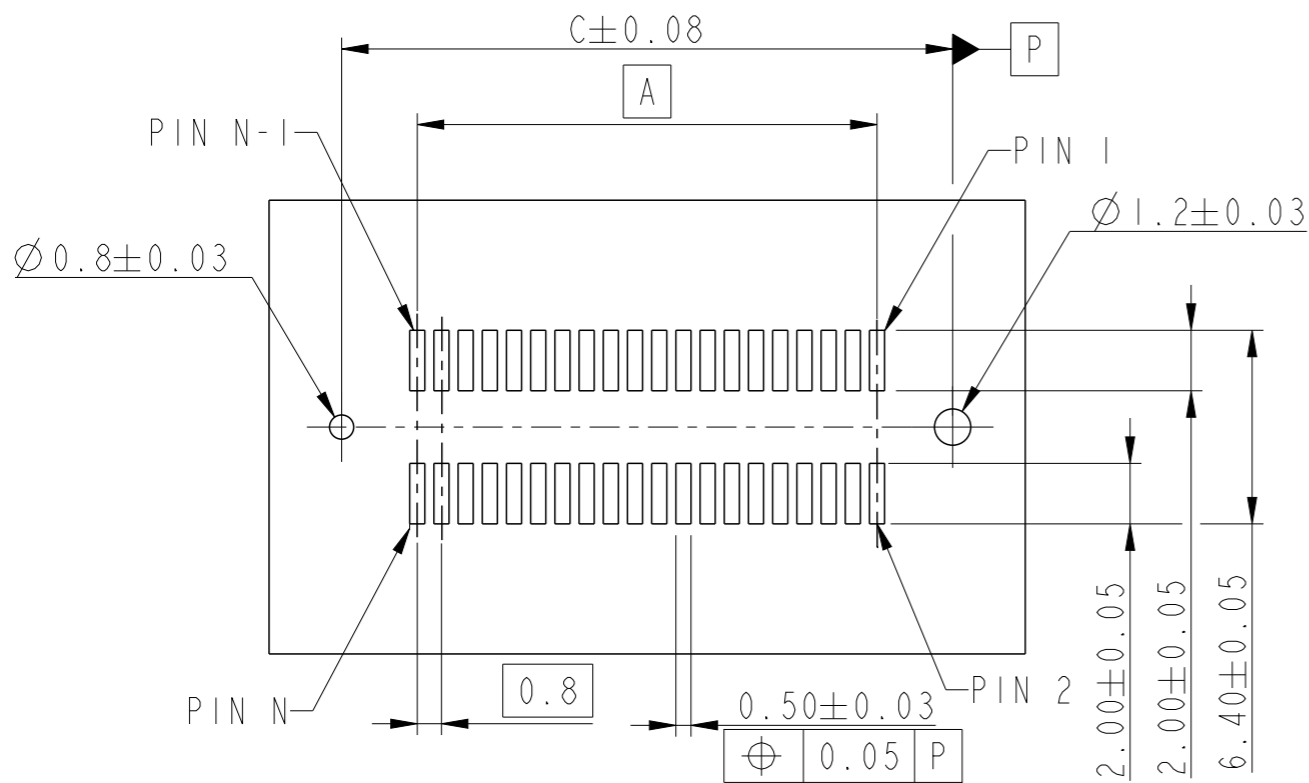

RECOMMENDED PCB LAYOUT WITH PEGS  
FOR NO. OF POSITION 2X70, 2X80, 2X90, 2X100

dr	Cheong, Matthe	2009/06/10	projection	MM	size	A3	scale	3:1
eng	Alan Ni	2022/11/03			ecn no ELX-N-46103-1			
chr	-	-			rel level Released			
appr	Tim Yao	2022/11/29	product family		-			
<b>Amphenol FCI</b>			title BERGSTAK 0.8MM RECEPTACLE ASS'Y		dwg no 61082		rev AR	
www.fci.com			cat. no. -		Product - Customer Drw		sheet 3 of 7	

PRODUCT NO.	NUMBER OF POSITIONS	DIMENSION		
		A	B	C
61082-022***	2X10	7.2	13.8	12.2
61082-042***	2X20	15.2	21.8	20.2
61082-062***	2X30	23.2	29.8	28.2
61082-082***	2X40	31.2	37.8	36.2
61082-102***	2X50	39.2	45.8	44.2
61082-122***	2X60	47.2	53.8	52.2
61082-142***	2X70	55.2	61.8	60.2
61082-162***	2X80	63.2	69.8	68.2
61082-182***	2X90	71.2	77.8	76.2
61082-202***	2X100	79.2	85.8	84.2

DATE CODE: XXXXXX

DAY(01~31)  
MONTH(01~12)  
YEAR(00~99)

DETAIL G

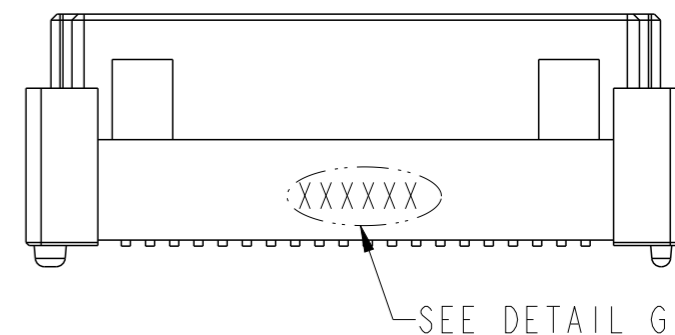
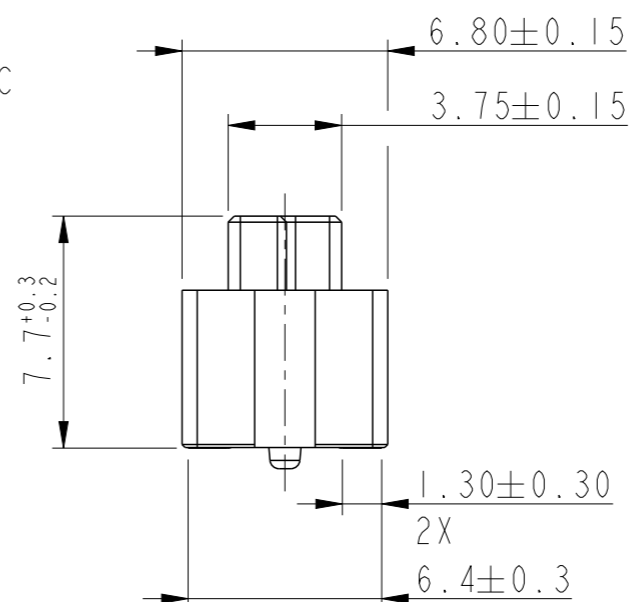
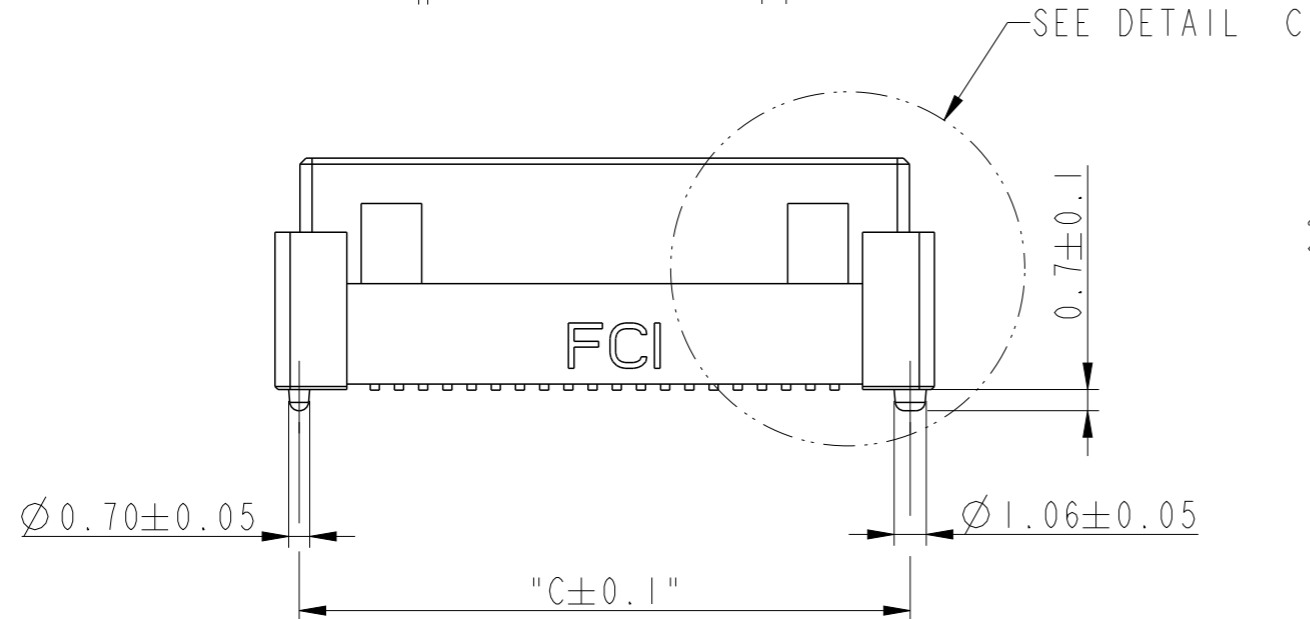
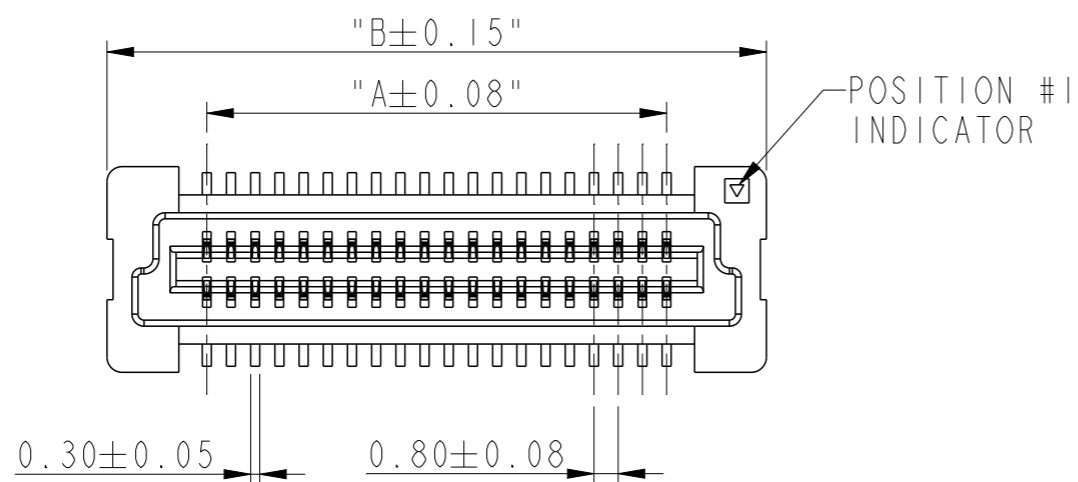
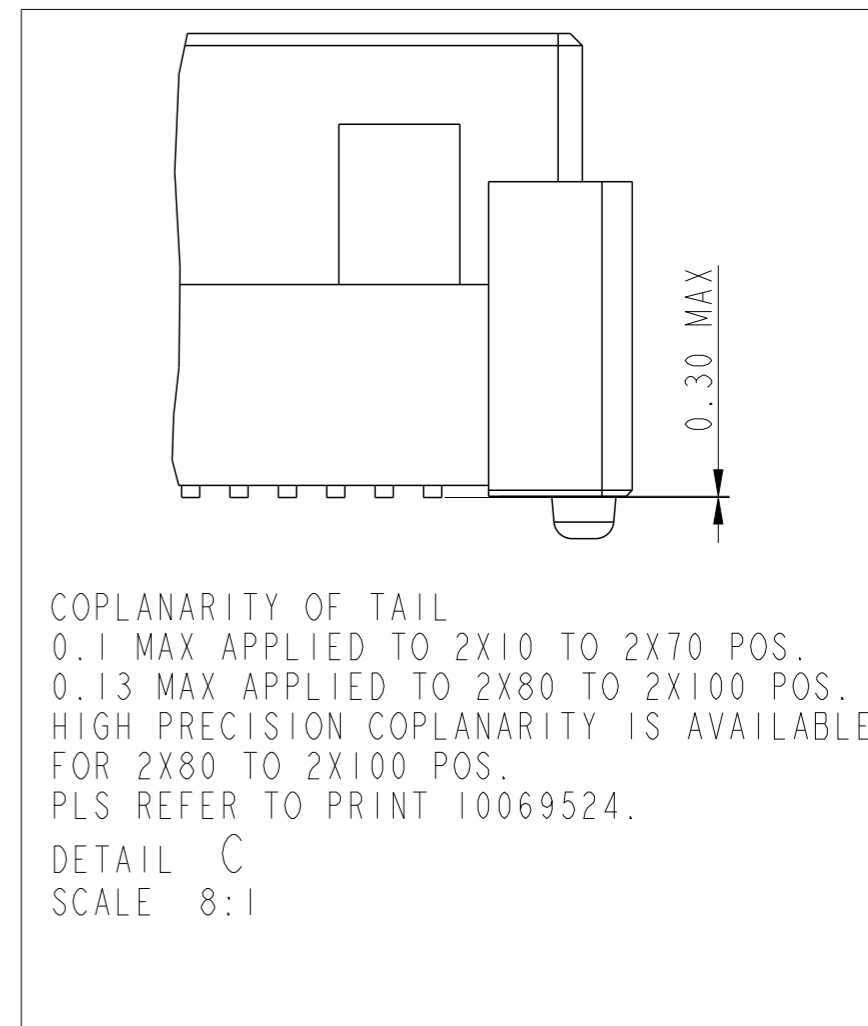

RECEPTACLE 2

dr	Cheong, Matthe	2009/06/10	projection	MM	size	A3	scale	3:1
eng	Alan Ni	2022/11/03			ecn no ELX-N-46103-1			
chr	-	-			rel level Released			
appr	Tim Yao	2022/11/29	product family		-			
Amphenol FCI		BERGSTAK 0.8MM			dwg no		61082	
www.fci.com		RECEPTACLE ASS'Y			cat. no.		-	
		Product - Customer Drw			sheet 4 of 7		rev AR	

PRODUCT NO.	NUMBER OF POSITIONS	DIMENSION		
		A	B	C
61082-023***	2X10	7.2	13.8	12.2
61082-043***	2X20	15.2	21.8	20.2
61082-063***	2X30	23.2	29.8	28.2
61082-083***	2X40	31.2	37.8	36.2
61082-103***	2X50	39.2	45.8	44.2
61082-123***	2X60	47.2	53.8	52.2
61082-143***	2X70	55.2	61.8	60.2
61082-163***	2X80	63.2	69.8	68.2
61082-183***	2X90	71.2	77.8	76.2
61082-203***	2X100	79.2	85.8	84.2

DATE CODE: XXXXXX  
 DAY(01~31)  
 MONTH(01~12)  
 YEAR(00~99)

DETAIL H

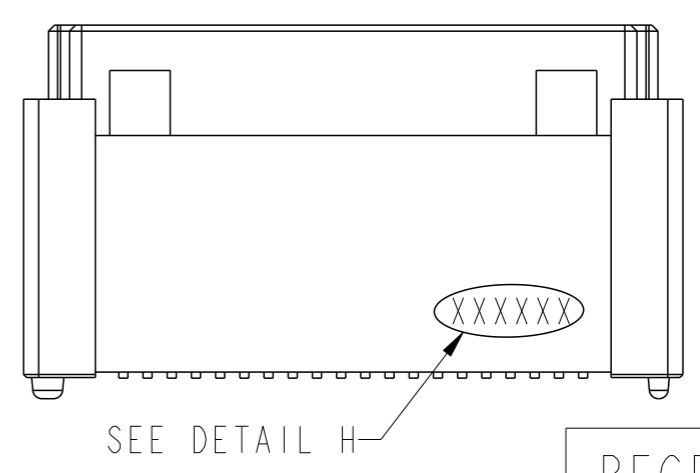
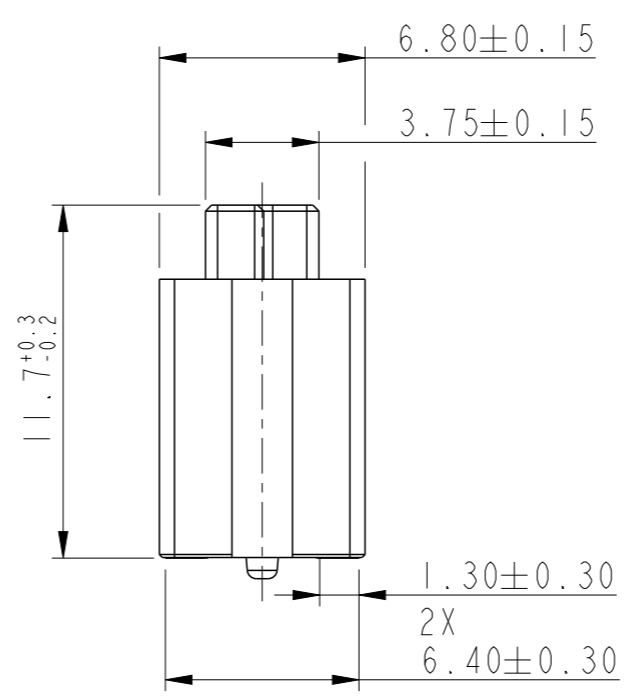
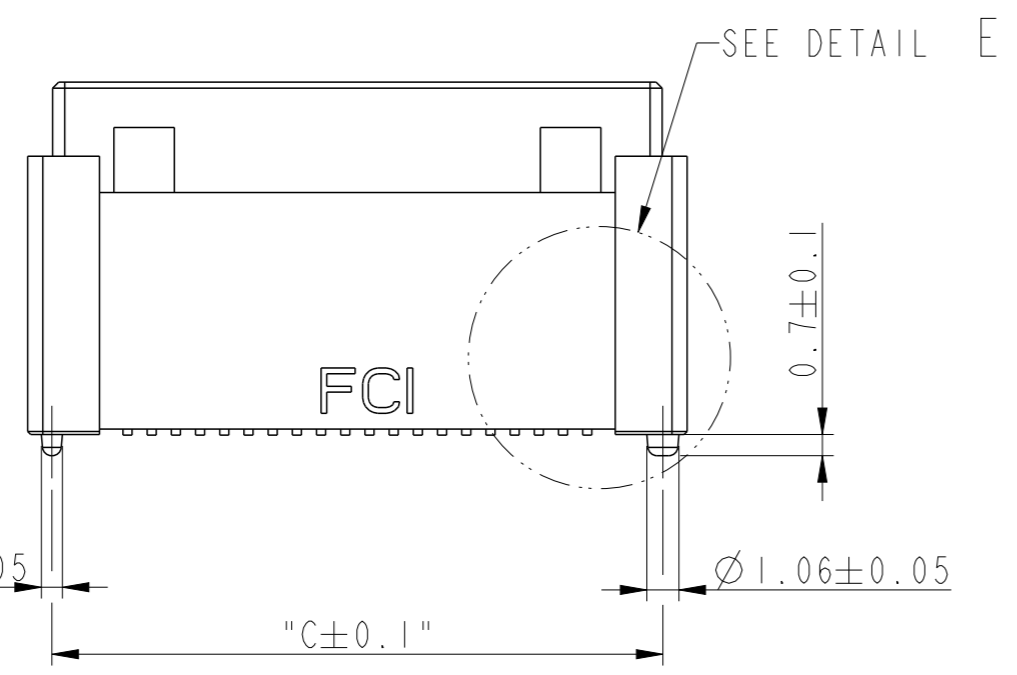
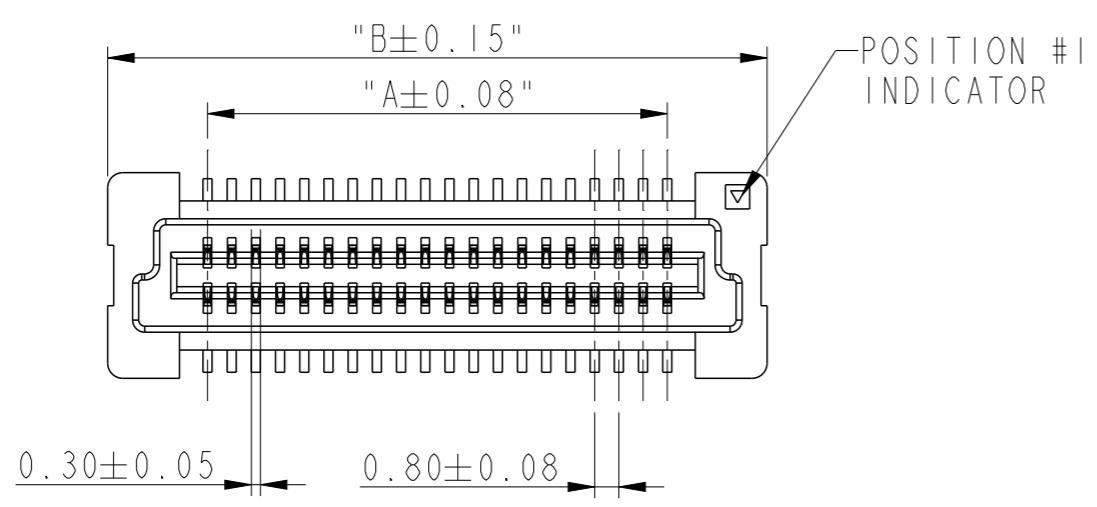
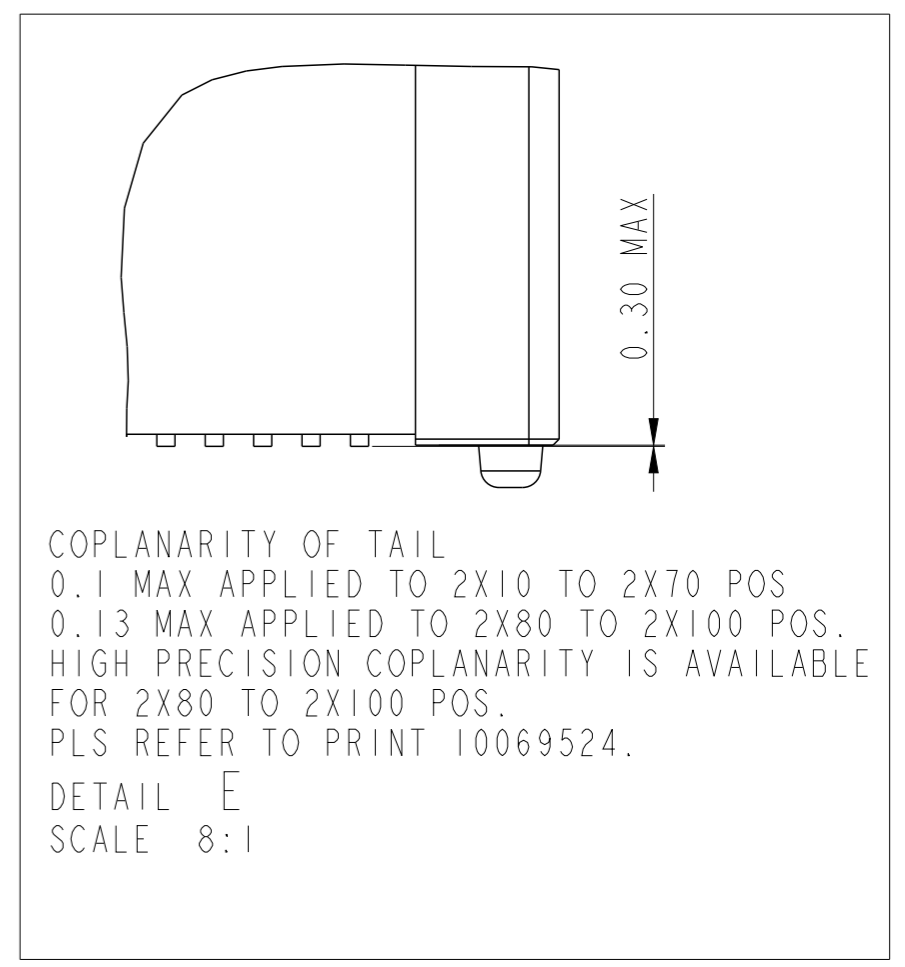

RECEPTACLE 3

dr	Cheong, Matthe	2009/06/10	projection	MM	size	A3	scale	3:1
eng	Alan Ni	2022/11/03			ecn no ELX-N-46103-1			
chr	-	-			rel level Released			
appr	Tim Yao	2022/11/29	product family	-	rel level Released			
Amphenol FCI		BERGSTAK 0.8MM			dwg no	61082		rev
www.fci.com		RECEPTACLE ASS'Y					AR	
cat. no.		-			Product - Customer Drw		sheet 5 of 7	

PRODUCT NO.	NUMBER OF POSITIONS	DIMENSION		
		A	B	C
61082-024***	2X10	7.2	13.8	12.2
61082-044***	2X20	15.2	21.8	20.2
61082-064***	2X30	23.2	29.8	28.2
61082-084***	2X40	31.2	37.8	36.2
61082-104***	2X50	39.2	45.8	44.2
61082-124***	2X60	47.2	53.8	52.2
61082-144***	2X70	55.2	61.8	60.2
61082-164***	2X80	63.2	69.8	68.2
61082-184***	2X90	71.2	77.8	76.2
61082-204***	2X100	79.2	85.8	84.2

DATE CODE: XXXXXX  
 DAY(01~31)  
 MONTH(01~12)  
 YEAR(00~99)

DETAIL K

COPLANARITY OF TAIL  
 0.1 MAX APPLIED TO 2X10 TO 2X70 POS  
 0.13 MAX APPLIED TO 2X80 TO 2X100 POS.

HIGH PRECISION COPLANARITY IS AVAILABLE FOR 2X80 TO 2X100 POS.  
 PLS REFER TO PRINT 10069524.

DETAIL J  
 SCALE 8:1

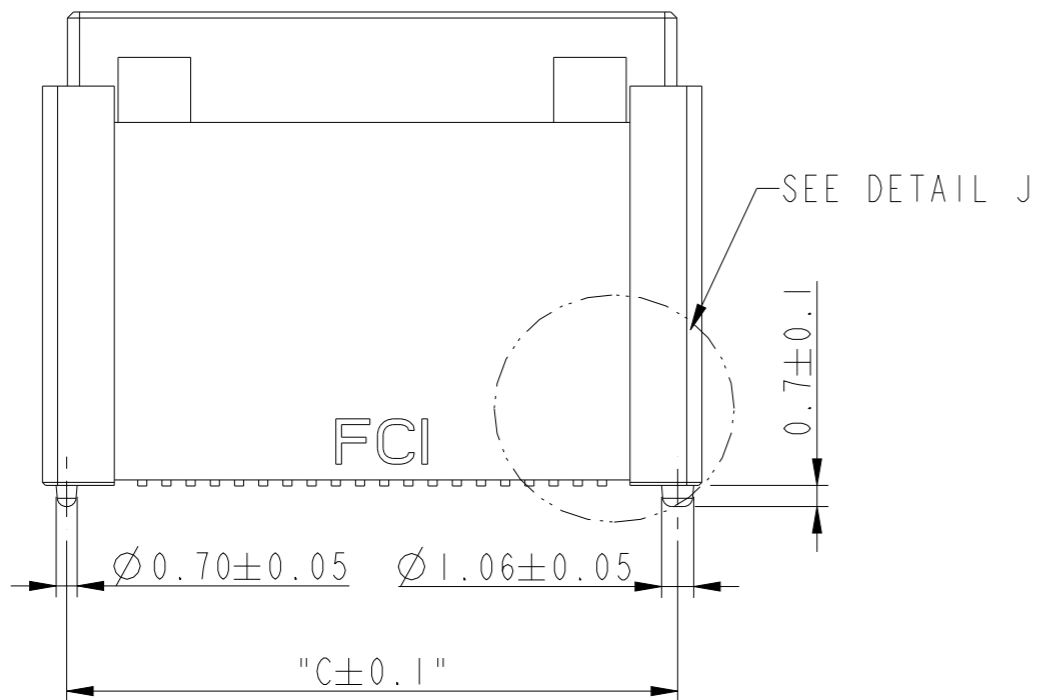
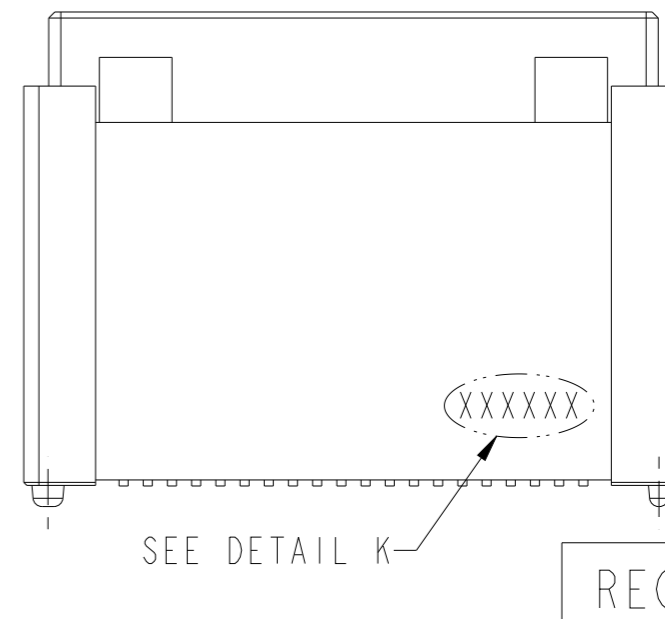
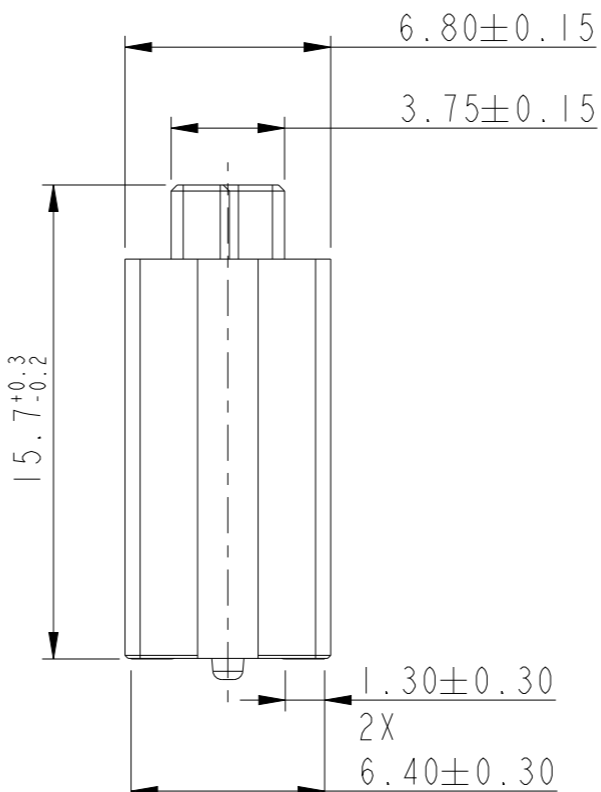
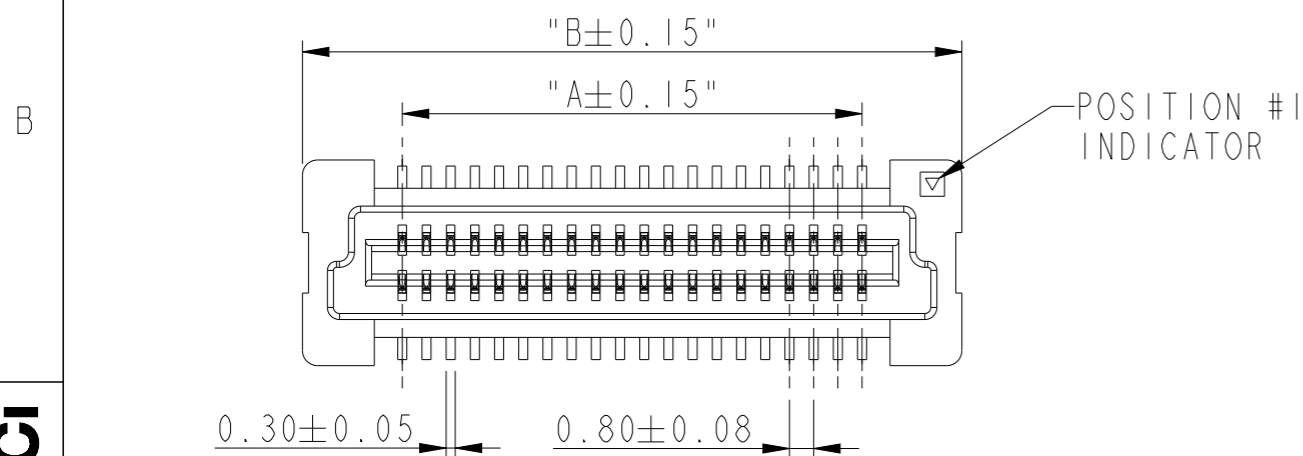

dr	Cheong, Matthe	2009/06/10	projection	MM	size	A3	scale	3:1	
eng	Alan Ni	2022/11/03			ecn no ELX-N-46103-1				
chr	-	-			rel level Released				
appr	Tim Yao	2022/11/29	product family	-	rel level Released				
Amphenol FCI		BERGSTAK 0.8MM			dwg no	61082		rev	AR
www.fci.com		cat. no.	-		Product - Customer Drw		sheet 6 of 7		

RECEPTACLE 2 & 3 & 4

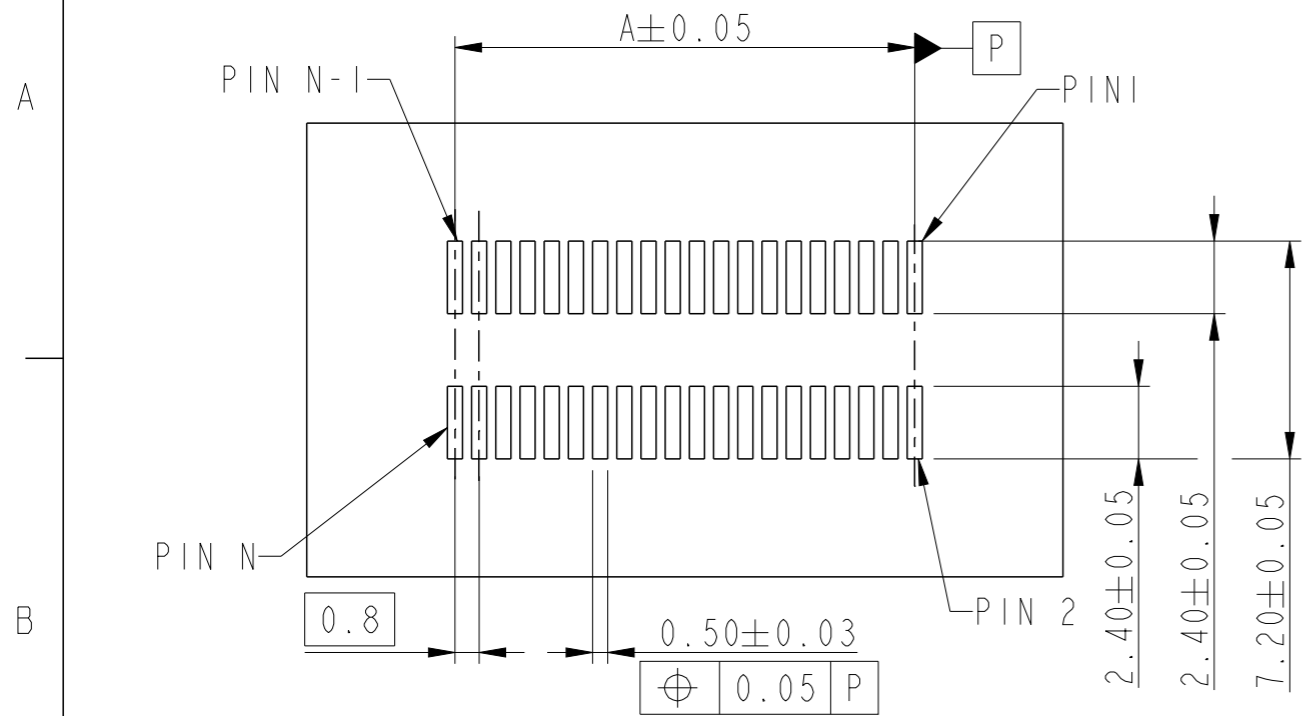

RECOMMENDED PCB LAYOUT WITHOUT PEGS

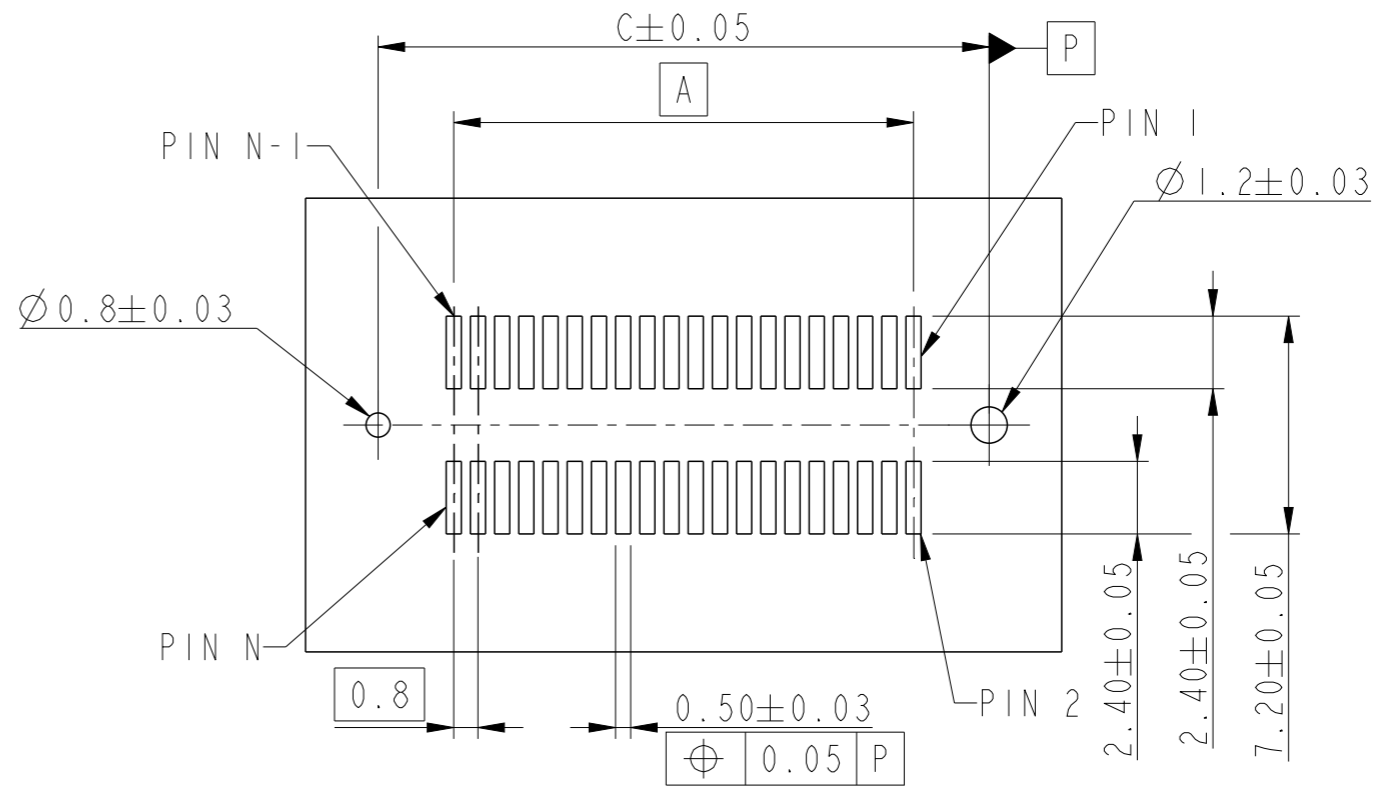

RECOMMENDED PCB LAYOUT WITH PEGS  
FOR NO. OF POSITION 2X10, 2X20, 2X30, 2X40, 2X50, 2X60

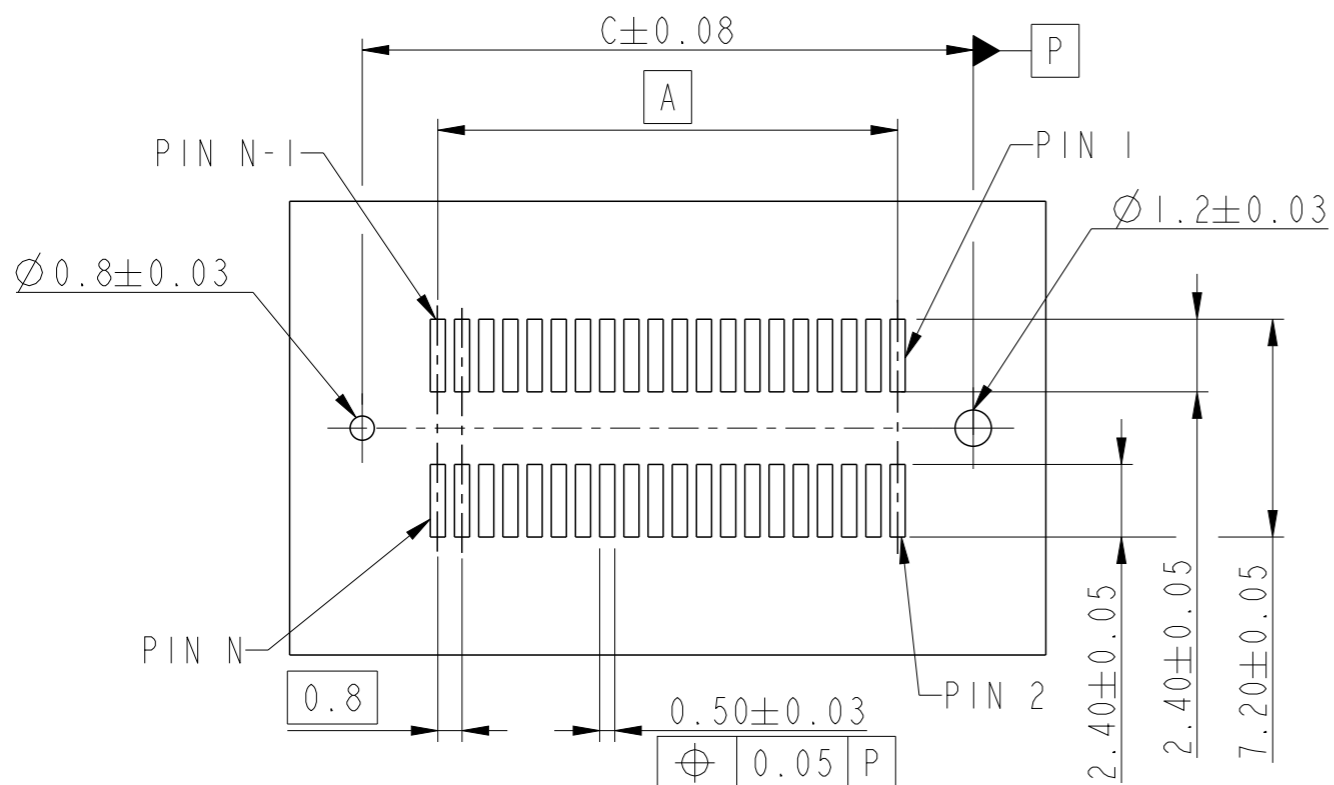

RECOMMENDED PCB LAYOUT WITH PEGS  
FOR NO. OF POSITION 2X70, 2X80, 2X90, 2X100

dr	Cheong, Matthe	2009/06/10	projection	MM	size	A3	scale	3:1
eng	Alan Ni	2022/11/03			ecn no ELX-N-46103-1			
chr	-	-			rel level Released			
appr	Tim Yao	2022/11/29	product family		-			
<b>Amphenol FCI</b>			title BERGSTAK 0.8MM RECEPTACLE ASS'Y		dwg no 61082		rev AR	
www.fci.com			cat. no. -		Product - Customer Drw		sheet 7 of 7	