



Description

SMA is an acronym for SubMiniature version A and was developed in the 1960's. It uses a threaded interface.

50 ohm SMA connectors are semi-precision, sub-miniature units which provide excellent electrical performance from DC to 18 Ghz. These high performance connectors are compact in size and mechanically have outstanding durability.

Built in accordance with MIL-C-39012 and CECC 22110/111. They can be mated with all connectors which meet these spec mating diameters regardless of manufacturer.

Features/Benefits

- Broadband performance DC to 18 GHz with low reflection stainless steel construction with 1/4-36 threaded coupling offers high performance in a compact design.
- Low cost Commercial Grade (Brass SMA) available in nickel or gold plating, flexible provides approximately 30% reduction in cost with 250 mating cycles.
- Various flexible cable groups including: .086 and .141 semi-rigid allows customer flexibility in their design with a durable connector.

Application

- Base Stations
- Cable Assemblies
- Components
- Instrumentation
- Mil/Aero
- PC/LAN
- Process Controls
- Telecom

Stainless Steel

Specifications	56-57
Plugs	58-61
Jacks	62-63
Receptacles	64-73
In-Series Adapters	74-75

Brass

Specifications	76
Plugs, Jacks	77-78
Receptacles	79-82

Phase Adjustable Connectors

Specifications	83
Plugs and Adapters	84

ELECTRICAL

Impedance	50 ohms
Frequency range	.141" & .085" O.D. copper jacket semi-rigid cable. 0-18GHz. Flexible cables: 0-12.4 GHz.
Voltage rating	RG-55, 58, 141, 142, 223, 303: 500 volts peak RG-122, 174, 188, 316, 375 volts peak
Dielectric withstanding voltage	.141" & RG-58 group: 1,000 VRMS. .085" & RG-316 group: 750 VRMS.
VSWR (straight connectors)	.141" O.D. copper jacket cable: 1.05 + .005 f (GHz) RG-55 group: 1.15 + .011 f (GHz) RG-122 group: 1.15 + .02 f (GHz) RG-178 group: 1.20 + .025 f (GHz)
(angle connectors)	.141" O.D. copper jacket cable: 1.10 + .01 f (GHz) RG-55 group: 1.15 + .02 f (GHz) RG-122 group: 1.15 + .03 f (GHz) RG-178 group: 1.20 + .03 f (GHz)
Contact resistance	Center: 2.0 milliohms Body: 2.0 milliohms Braid to body: 0.5 milliohms
Insulation resistance:	5000 megohms
RF leakage	-60 dB minimum
Insertion loss:	.03 \sqrt{f} (GHz) dB max.

ENVIRONMENTAL

Temperature range	-65°C to + 165°C
Thermal shock	MIL-Std. 202 method 107 (test cond. B) except high temp test @ + 200°C
Vibration	MIL-Std. 202 method 204 (test cond. D)
Shock	MIL-Std. 202 method 213 (test cond. I) No discontinuity permitted.
Corrosion	MIL-Std. 202 method 101 (test cond. B) 5% salt solution.
Moisture resistance	MIL-Std. 202 method 106, except step 7b (vibration) omitted, and high humidity measurements do not apply.
Weatherproofing	Crimp type: heat shrink tubing Solder type: silicone rubber gaskets
Altitude	MIL-Std. 202 method 105 (test cond. C), no corona at 70,000 ft. .141" & RG-55 group: 250 VRMS. .085" & RG-122 group: 190 VRMS.

MECHANICAL

Mating	.250-36 threaded coupling
Mating torque	Minimum: 2 inch pounds 22 N.cm Recommended: 7 to 10 inch pounds 80-110 N.cm Maximum: 15 inch pounds 170 N.cm
Coupling nut retention	Axial force: 100 lbs. min., 300 N.cm Torque: 15 in. lbs. min. 76 N.cm Jacks: N/A
Connector affixment to cable	Crimp types, solder types
Cable affixment to center contact	Solder, except as noted
Contact captivation	All types, except as noted
Cable retention	Crimp type for RG-58, .141, 303=60 lbs min.; for RG-55, 142, 223 = 80 lbs min. 400 N.cm
Connector durability	500 mating and unmating cycles @ 12 cycles per min.

MATERIAL

Bodies, coupling nuts, other metal parts (except as noted)	Non-magnetic stainless steel per QQ-S-764, Type 303.
Contacts	Beryllium copper per QQ-C-530, heat treated per MIL-H-7199.
Plating: Center contacts.	.00005" min. gold per MIL-G-45204, type 1, grade C. Gold over nickel unless otherwise requested.
Plating: Other metal parts	Gold plated or passivated to meet the finish and corrosion requirements of MIL-C-39012.
Insulators	TFE fluorocarbon per ASTM D1457.
Gaskets	Silicone rubber, per MIL-R-5847 and ZZ-R-765. class IIB, grade 65-75.
Lockwashers	Stainless steel, internal-tooth supplied with all bulkhead mounted connectors.
Crimp ferrules	Seamless copper tubing alloy # 122 (DHP), hard drawn to Rockwell 58-77 on 30-T scale per ASTM B75.

MILITARY SPECIFICATIONS

MIL-C-39012 & MIL-C-83517 SMA specification sheets	As applicable
--	---------------

NOTE: These characteristics are typical and may not apply to all connectors.

Plug

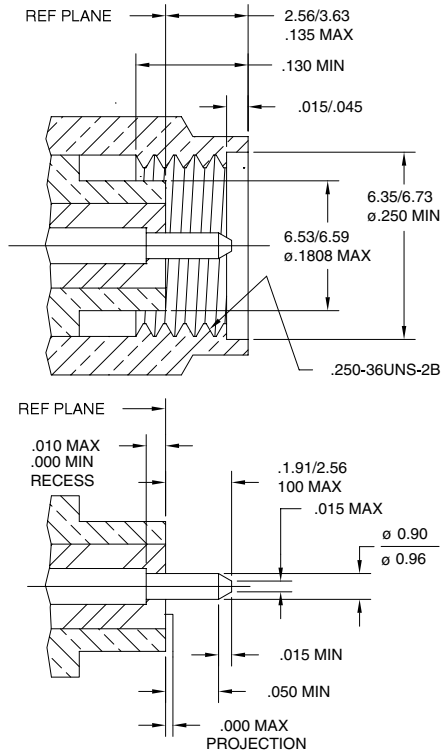

Jack

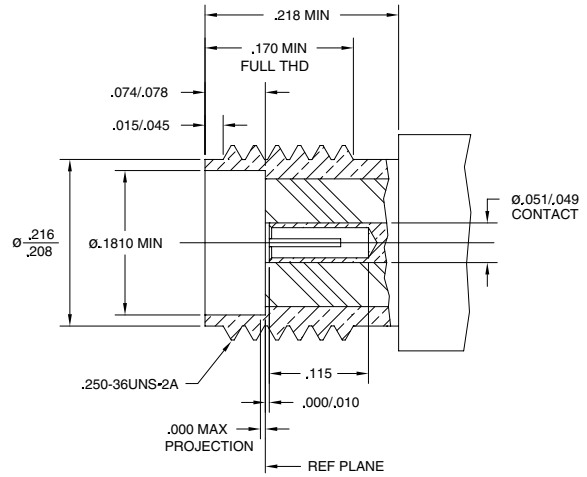

CECC = Cenelec Electronic Components Committee in Europe

Amphenol has available a line of 50 ohm SMA brass connectors as a cost effective solution for applications where stainless steel construction is not required. This gives the design engineer flexibility with performance to complete projects with world class components.

Amphenol series 901 SMA brass connectors are semi-precision, subminiature units which provide electrical performance from DC to 18 GHz. These high performance connectors are compact in size and mechanically have outstanding durability.

Features/Benefits

- Amphenol brass SMA connectors feature pre-assembled captive center contacts, brass body and coupling nuts.
- Connectors are built in accordance with MIL-C-39012.
- Can be mated with all connectors which meet the military specification mating diameters regardless of manufacturer.
- Available for .085" and .141" diameter semi-rigid cables and all the standard flexible cables including double shielded RG-316.
- Connectors are adaptable to the interconnection requirements of both systems and components.

SPECIFICATIONS*

ELECTRICAL

Impedance	50 ohms
Frequency range	.141" & .085" O.D. copper jacket semi-rigid cable. 0-18GHz. Flexible cables: 0-12.4 GHz.
Voltage rating	RG-58,141,142: 500 volts peak RG-174, 188, 316:, 375 volts peak
Dielectric withstanding voltage	.141" & RG-58 group: 1,000 VRMS. .085" & RG-316 group: 750 VRMS.
VSWR (straight connectors)	.141" O.D. semi-rigid cable: 1.05 + .005 f RG-174 group: 1.15 + .02 f RG-58 group: 1.15 + .01 f RG-178 group: 1.20 + .025 f
Contact resistance	Center: 2.0 milliohms Body: 2.0 milliohms Braid to body: 0.5 milliohms
Insulation resistance:	5000 megohms
RF leakage	-90 dB min. at 2.3 GHz
Insertion loss:	dB max. = $.06 \sqrt{f(\text{GHz})}$ Test frequency @ 6.0 GHz

MATERIAL

Bodies, coupling nuts, other metal parts (except as noted)	Brass per QQ-B-626
Contacts Male: Female:	Brass Beryllium copper, heat treated
Plating: Center contacts,	.000030" min. gold
Plating: Other metal parts	Standard .000010" gold or nickel plated
Insulators	TFE fluorocarbon
Gaskets	Silicone rubber
Crimp ferrules	Seamless copper tubing alloy

MECHANICAL‡

Mating	.250-36 Threaded coupling
Mating Torque	Minimum: 2 inch pounds 12 N.cm Recommended: 8 to 10 inch pounds 45 N.cm Maximum: 15 inch pounds 60 N.cm
Connector Durability	100 matings

* These characteristics are typical and may not apply to all connectors.

‡ Pressure applied on an SMA outer contact is extremely high; therefore inadequate torque of connector body will result in a slight deformation of the outer contact. Reflections will appear above 2GHz.

For phase array radar, test equipment, ILS landing systems and other instrumentation using phase matching techniques, these SMA connectors for semi-rigid coaxial cables and the SMA plug-to-Jack adapter offer a precise and simple means of phase adjustment for microwave devices.

Features/Benefits

- Connectors incorporate a threaded interconnection of variable length.
 - Adjustment nut creates incremental changes in connector length and angle.
 - Proper phase setting for each cable is maintained by connector locking-nuts.
- (For example, one revolution of the adjustment nut results in a phase angle change of 5.7° for a 9 GHz signal [0.636 x 9]°.)*
- Connectors provide ease of mechanical screw adjustments, compared to the delays and expense of laborious cable-trimming.
 - Allow phase matching to be performed at the final production stages.

SPECIFICATIONS*

ELECTRICAL

Impedance	50 ohms
Frequency range	DC-18GHz.
Insertion loss:	dB max. For Adapter 901-508 = $.1 \sqrt{f(\text{GHz})}$ For Plug 901-509 = $.08 \sqrt{f(\text{GHz})}$
VSWR	See chart below
Phase Angle Adjustment Range in degrees	For Adapter 901-508 and Plug 901-509, = 0° to $[10 \times f(\text{GHz})]^\circ$ max
Phase Angle change per revolution of Adjustment Nut in degrees	For Adapter 901-508 and Plug 901-509, = $[0.636 \times f(\text{GHz})]^\circ$
Voltage rating	500 VRMS peak

MECHANICAL

Mating	Mating face dimensions compatible with the mating requirements of MIL-C-39012/55 (Type SMA)
Connector Durability	(SMA interface) 500 cycles of mating and unmating without deterioration

MATERIAL

Center Contact	Beryllium copper, Gold plated
Connector Body	Brass or Beryllium Copper, Gold plated
Adjusting Nuts and Locking Nuts	Brass with ASTRO plate finish
Connector Coupling Nut	Stainless Steel, Passivated
Insulation	TFE

SWEPT VSWR DATA

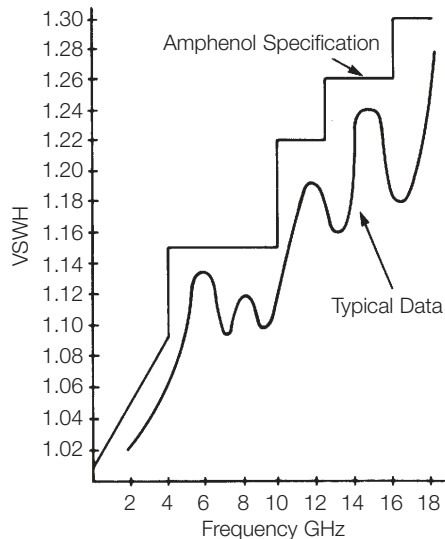

ENVIRONMENTAL

Shock	MIL-Std. 202 method 213 (test cond. I)
Vibration	MIL-Std. 202 method 204 (test cond. D)
Corrosion	MIL-Std. 202 method 101 (test cond. B)
Temperature range	-65°C to + 125°C

* These characteristics are typical and may not apply to all connectors.