

Features

- Frequency range : 32.768 kHz
- SMD : Ceramic package
- External dimensions (mm)
L : 3.2 x W : 1.5 x H : 0.75
- RoHS compliant & Pb free

Applications

- Small mobile devices
- Communication devices
- Consumer products
- Commercial & industrial applications

Electrical Characteristics

Item	Symbol	QT3C	Conditions
Nominal Frequency	f_0	32.768 kHz	
Frequency Tolerance	$\Delta f/f_0$	$\pm 10\text{ppm}$, $\pm 20\text{ppm}$, $\pm 30\text{ppm}$	at 25°C
Load Capacitance	C_L	6pF, 7pF, 9pF, 12.5pF	
Operating Temperature Range	T_{OTR}	-40°C ~ +85°C	
		-40°C ~ +125°C	
Storage Temperature Range	T_{STR}	-55°C ~ +125°C	
Turnover Temperature	T_M	25°C \pm 5°C	
Temperature Coefficient	β	-0.04 ppm/°C ² Max.	
Motional Capacitance	C_1	3.1 fF Typ.	
Motional Resistance (ESR)	R_1	70 kΩ Max.	at 25°C
Drive Level	D_L	0.1μW Typ. / 1.0μW Max.	
Aging	$\Delta f/f_0$	± 3 ppm Max.	at 25°C \pm 3°C, first year
Shunt Capacitance	C_0	1.0 pF Typ.	

Dimensions

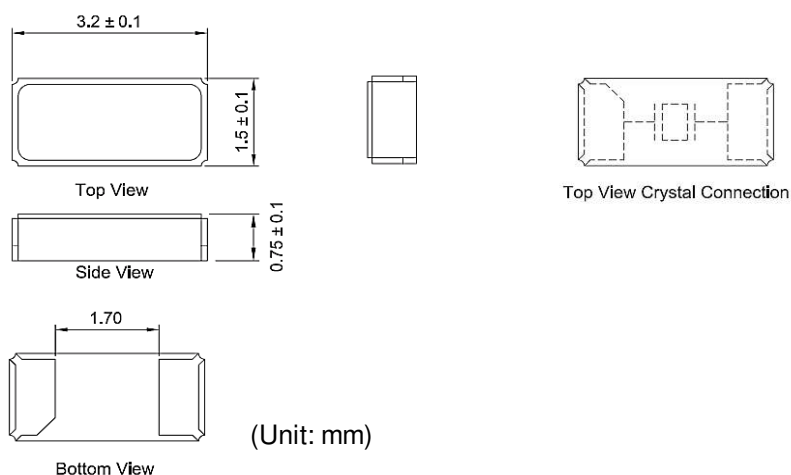

Ordering Information

QT3C - 32.768K D Z F - T

Frequency Tolerance (at 25°C)	Package Method
A ± 30 ppm	T Tape & Reel
D ± 20 ppm	
E ± 10 ppm	
Operating Temperature Range	Load Capacitance
Z -40°C ~ +85°C	B 6 pF
W -40°C ~ +125°C	Y 7 pF
	C 9 pF
	F 12.5 pF

Packing

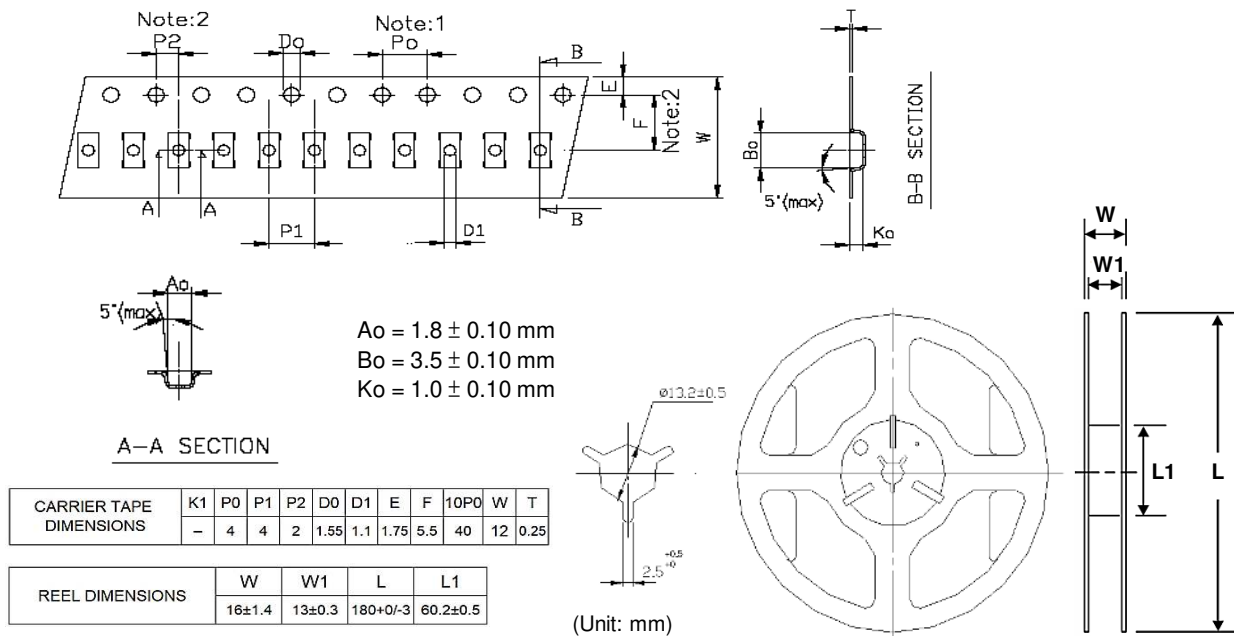

Reflow Profile

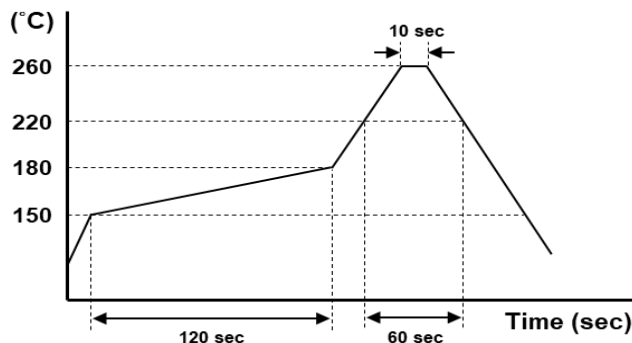

Total time : Max. 200 sec.
Solder melting point : 220°C