

PART NUMBER	REVISION	DESCRIPTION	FEED TYPE
2151985-1	E	FINE CRIMP HEIGHT ADJUST	MECHANICAL
2151985-2	E	FINE CRIMP HEIGHT ADJUST	PNEUMATIC
7-2151985-1	E	MECHANICAL AND CRIMP TOOLING KIT	MECHANICAL
7-2151985-2	E	PNEUMATIC AND CRIMP TOOLING KIT	PNEUMATIC
7-2151985-7	A	CRIMP TOOLING KIT	-

ATLANTIC VERSION TERMINATOR INTERFACE ADAPTER

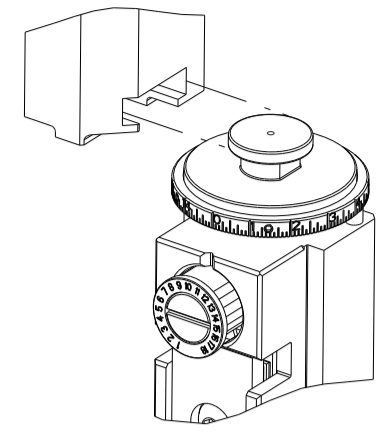

APPLICATOR DATA		
CRIMP	SIZE	TYPE
WIRE	1.40 mm [.055]	F
INSUL	1.57 mm [.062]	O

APPLICATOR INSTRUCTIONS
408-35042

TERMINAL DATA: TE TERMINAL		TE CRIMP SPECIFICATION	
TERMINAL NAME: CONTACT, TWIN LEAF			
WIRE STRIP LENGTH	INSULATION DIAMETER RANGE		
3.18-3.96 mm [.125-.156 IN]	Ø1.22-1.52 mm [.048-.060 IN]		
TERMINAL APPLICATION SPECIFICATION	114-9004		
TERMINALS APPLIED			
TE TERMINAL	TE TERMINAL	TE TERMINAL	TE TERMINAL
583853-1	583853-8	1-583853-3	5-583853-3
531477-2	5-531477-2	5-531477-4	531477-4

WIRE SIZE	CRIMP HEIGHT mm [INCH]	CRIMP HEIGHT REFERENCE SETTING
20 AWG OR 0.50mm2	1.02 +/- 0.05 [.040 +/- .002]	5.2
0.35mm2	0.92 +/- 0.05 [.036 +/- .002]	6.4
22 AWG OR 0.30mm2	0.92 +/- 0.05 [.036 +/- .002]	6.4
0.25mm2	0.86 +/- 0.05 [.034 +/- .002]	7.0
24 AWG OR 0.20mm2	0.84 +/- 0.05 [.033 +/- .002]	7.2

- 1 RECOMMENDED SPARE PARTS
- 2 REFER TO SUPPLIED INSTRUCTION SHEET FOR CLEANING, LUBRICATION AND STORAGE OF APPLICATOR.
- 3 APPLY PART NUMBER 2-23419-6 LOCTITE TO THREADS OF ITEM 242.
- 4 CRIMP HEIGHT REFERENCE SETTING WAS THE SETTING USED WHEN THE APPLICATOR WAS QUALIFIED AT THE FACTORY. ADJUSTMENT MAY BE NECESSARY WHEN RUNNING APPLICATOR IN THE FIELD.
- 5. UNLESS SPECIFIED OTHERWISE TORQUE VALUES SHALL BE USED PER DOCUMENT, 101-35000.
- 6 TERMINAL LUBRICANT IS RECOMMENDED

***WARNING**
ON INSTALLATION, SET WIRE DISC TO CRIMP HEIGHT REFERENCE SETTING FOR LARGEST WIRE SIZE. CRIMP HEIGHT REFERENCE SETTINGS GREATER THAN THE VALUE SHOWN MAY CAUSE DAMAGE TO THE CRIMP TOOLING. REFER TO THE INSTRUCTION SHEET FOR PROPER SETUP AND ADJUSTMENTS.

LOC	DIST	REVISIONS					
A	66	P	LTN	DESCRIPTION	DATE	OWN	APVD
		B		ECR-18-007107	09MAY2018	MZ	CT
		C		ECR-18-010235	02JUL2018	YY	TE
		D		ECR-21-001727	10FEB2021	JWC	TE
		E		ECR-22-138301	07MAY2022	FZ	GB

1	-	1	1	1	2280441-1	INSERT, SHEAR	282				
	-	1	-	1	2119641-1	FEED CAM, AIR FEED	248				
	-	1	1	1	2119082-9	CAM, SNAIL, INSULATION ADJUSTMENT	244				
	-	1	1	1	2079764-1	WASHER, WAVE SPRING, CREST-TO-CREST	243				
3	-	1	1	1	2119083-1	RETAINER, INSULATION DIAL	242				
	-	2	2	2	7-18023-7	SCR, SKT HD CAP M3 X 4.0	241				
	-	-	1	-	2119580-1	MECHANICAL FEED ASSEMBLY	239				
	-	1	-	1	2844940-1	AIR FEED MODULE	238				
	-	1	1	1	356885-4	STOP, SHEAR	237				
	-	REF	REF	REF REF	994970-2	COUNTER, MAGNETIC	164				
	-	1	1	1	1-18028-2	WASHER, FLAT, REG M4	119				
6	-	1	1	1	2119955-1	ASSY, LUBRICATOR, SIDE FEED	113				
	-	1	1	1	2844908-1	SCREW, LOCKING	99				
	-	1	1	1	2844907-1	POST, LOCKING	98				
	-	1	1	1	1-690438-0	FRONT STRIP GUIDE	96				
	-	2	2	2	2168083-1	SCR, SKT HD CAP, RoHS, M3 X 8.0	95				
	-	1	1	1	455888-6	SPACER, CRIMPER	82				
	-	1	1	1	5-240641-6	SPACER	81				
	-	1	1	1	1633782-2	FENCE	78				
	-	1	1	1	5-547505-2	SPRING, COMPRESSION	77				
	-	2	2	2	2168083-1	SCR, SKT HD CAP, RoHS, M3 X 8.0	76				
	-	1	1	1	854769-4	HOLDER, INS	74				
	-	1	1	1	1803607-3	DOCUMENTATION PACKAGE	71				
	-	1	1	1	2119740-1	TAG, IDENTIFICATION	67				
	-	2	2	2	2168078-1	SCREW, DRIVE, RH, RoHS, 2 x .188	66				
	-	2	2	2	2-18032-5	SCR, SET, FLT PNT, M5 X 20.0	61				
	-	1	1	1	2168083-2	SCR, SKT HD CAP, RoHS, M4 X 8.0	60				
	-	1	1	1	5-18022-5	SCR, HEX HD CAP, M4 X 6.0	59				
	-	1	1	1	21028-2	PIN, SLOTTED SPRING .062 X .250	58				
	-	1	1	1	1338685-1	PAWL, FEED	56				
	-	4	4	4	2168083-3	SCR, SKT HD CAP, RoHS, M4 X 12.0	54				
	-	2	2	2	2168083-9	SCR, SKT HD CAP, RoHS, M4 X 20	53				
	-	1	2	1	18023-9	SCR, SKT HD CAP M4 X 6.0	49				
	-	-	1	-	2119652-1	FEED CAM, PRE FEED	48				
	-	-	1	-	2119653-1	FEED CAM, POST FEED	47				
	-	1	1	1	1803583-9	APPLICATOR BASIC ASSEMBLY, SF	46				
	-	1	1	1	1803515-1	RAM ASSEMBLY, SF ATLANTIC	44				
	-	1	1	1	1803602-1	SCR, BHSC, RoHS (M8 X 25)	41				
	-	2	2	2	2079383-5	SCR, BHSC, RoHS (M4 X 20)	33				
	-	2	2	2	2-2844962-3	SPACER, CYLINDRICAL, STRIP GUIDE	30				
	-	1	1	1	2844992-3	ASSEMBLY, STRIP GUIDE	29				
	-	1	1	1	1-455888-0	SPACER, CRIMPER	28				
	-	2	2	2	22283-1	SPRING, COMPRESSION	27				
	-	1	1	1	356835-1	LEVER, DRAG RELEASE	26				
	-	1	1	1	240792-1	DRAG, TERMINAL	25				
	-	1	1	1	1320928-2	STRIP GUIDE	24				
	-	1	1	1	980371-4	SCR, SKT HD SHLDR 5.0 DIA X 6.0	23				
	-	1	1	1	2168083-2	SCR, SKT HD CAP, RoHS, M4 X 8.0	21				
	-	1	1	1	1-18028-2	WASHER, FLAT, REG M4	20				
	-	1	1	1	2119533-1	STRIPPER, SIDE FEED	19				
	-	1	1	1	1-690518-1	HOLD DOWN, TERMINAL	18				
1	-	1	1	1	690463-1	FLOATING SHEAR, REAR	17				
	-	2	2	2	1-2168083-1	SCR, SKT HD CAP, RoHS, M3 X 6	16				
	-	1	1	1	690691-9	PLATE, REAR SHEAR	15				
1	-	1	1	1	2119862-1	SHEAR HOLDER, REAR	14				
1	-	1	1	1	2119806-1	INSERT, SHEAR	13				
	-	2	2	2	3-22280-3	SPRING, COMPRESSION	12				
	-	1	1	1	1-356885-4	STOP, SHEAR	11				
1	-	1	1	1	2119805-1	SHEAR HOLDER, FRONT	10				
1	-	1	1	1	1803095-1	FLOATING SHEAR, FRONT	9				
1	1	2	2	1	2-1333201-8	ANVIL, COMBINATION	8				
	-	-	-	-	-	-	7				
	-	1	1	1	690468-1	DEPRESSOR SHEAR, REAR	6				
	-	1	1	1	2119780-5	DEPRESSOR, SHEAR	5				
	-	1	1	1	238011-7	BLOCK, CRIMPER SPACER	4				
1	1	2	2	1	1633966-6	CRIMPER, INSULATION O	3				
	-	1	1	1	455888-3	SPACER, CRIMPER	2				
1	1	2	2	1	2-456402-6	CRIMPER, WIRE PREMIUM	1				
	-	77	-	72	-	2	-	1	PART NO	DESCRIPTION	ITEM NO

ATLANTIC VERSION
Shown on sheets 1 of 4 & 2 of 4
(Pacific version shown on sheets 3 of 4 & 4 of 4)

DIMENSIONS:		TOLERANCES UNLESS OTHERWISE SPECIFIED:		MATERIAL:		WEIGHT:		SCALE:		SHEET:		REV:			
mm	0 PLC ±	1 PLC ±	2 PLC ±	3 PLC ±	4 PLC ±	ANGLES ±	FINISH	Customer Accessible Production Drawing	SCALE	1:2	SHEET	1	OF	4	
OWN: H. HUANG 20JUN2013		CHK: L. ZHANG 20JUN2013		APVD: U. GUO 20JUN2013		NAME: Ocean Side Feed Applicator		SIZE: A1		CAGE CODE: 00779		DRAWING NO: C=2151985		RESTRICTED TO: E	

LOC		DIST		REVISIONS			
A	66	P	LTN	DESCRIPTION	DATE	OWN	APVD
		-		SEE SHEET 1			

FEED TYPE MECHANICAL

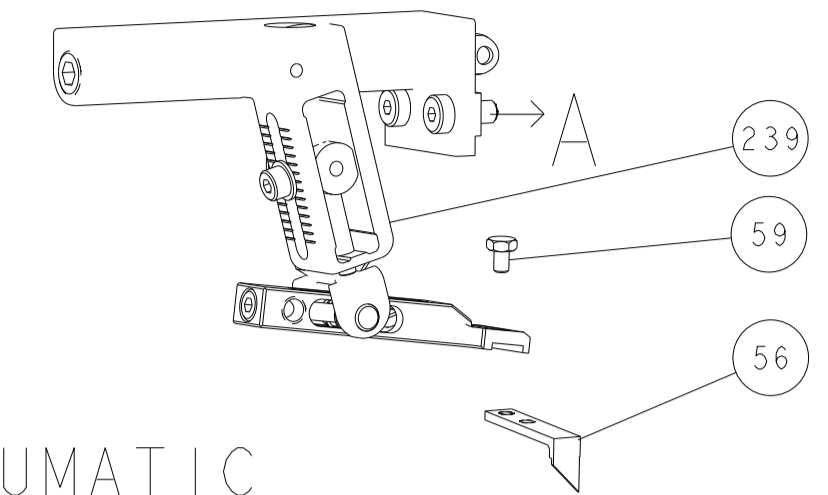

PNEUMATIC

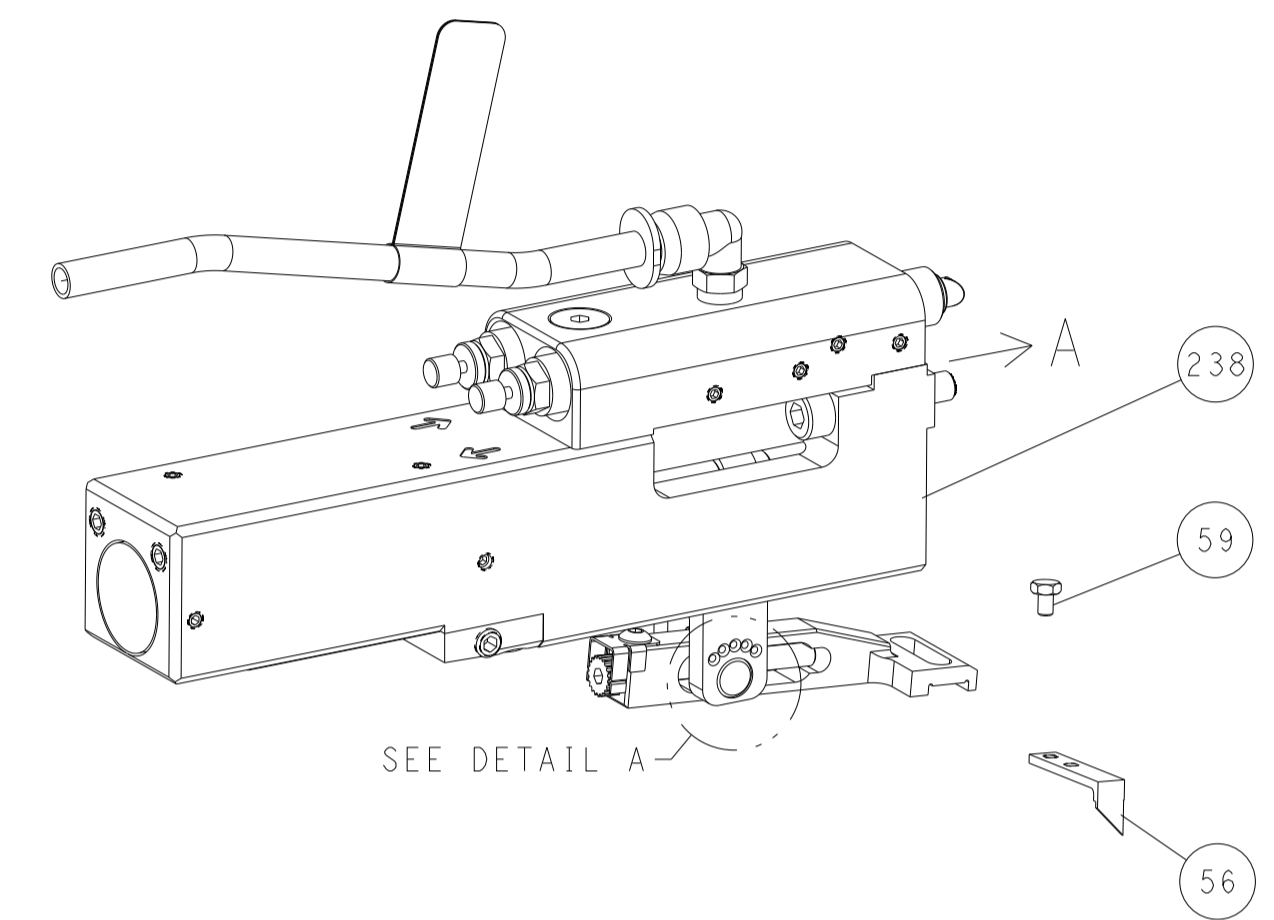

FEED SPRING SETTING POSITION (SHOWN FROM REAR SIDE)



DETAIL A

CAM POSITIONS

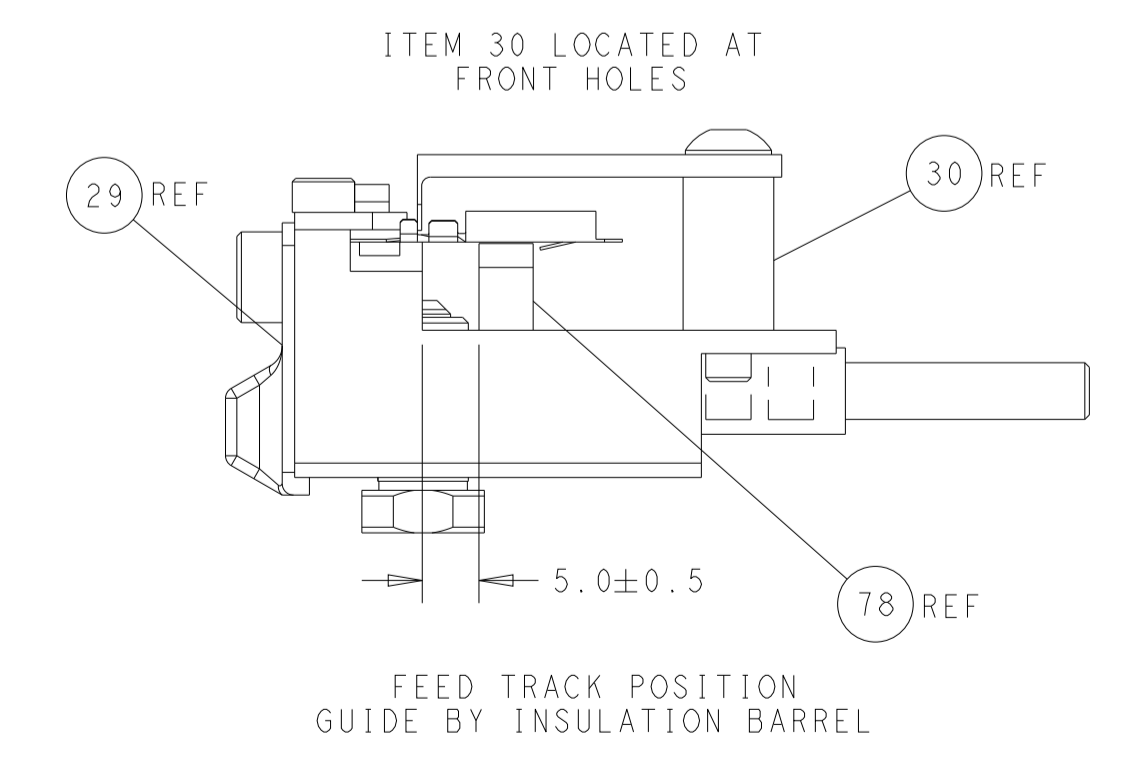
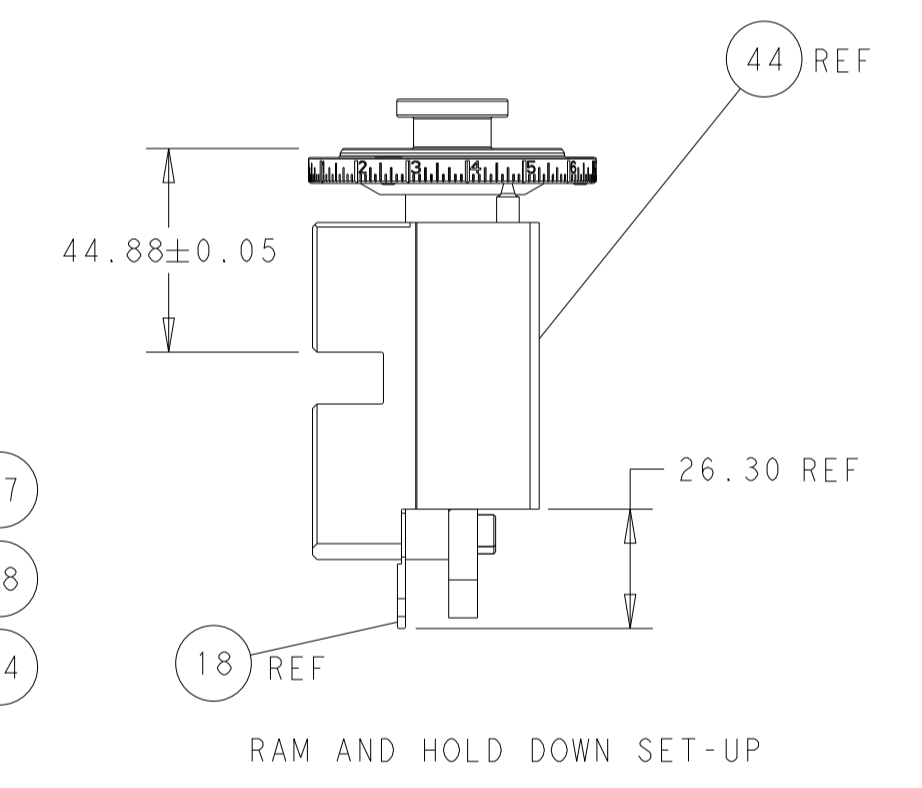
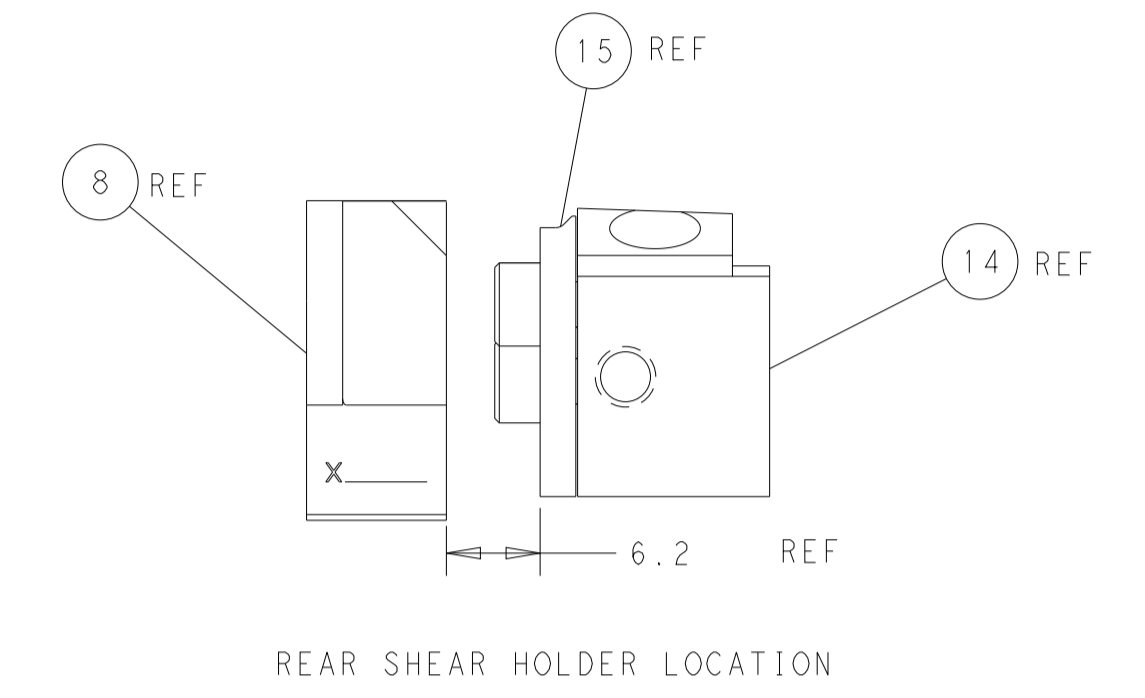
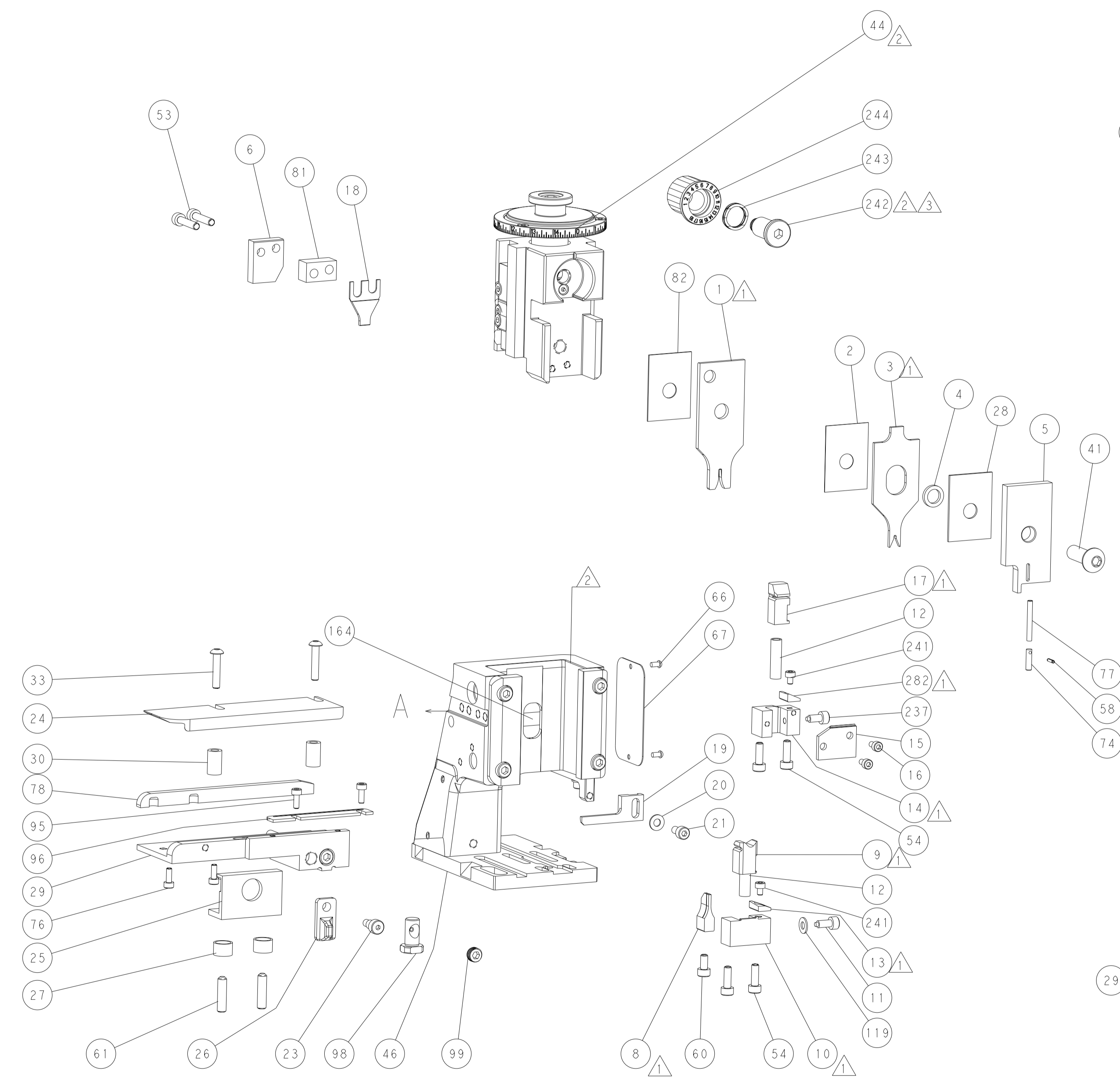
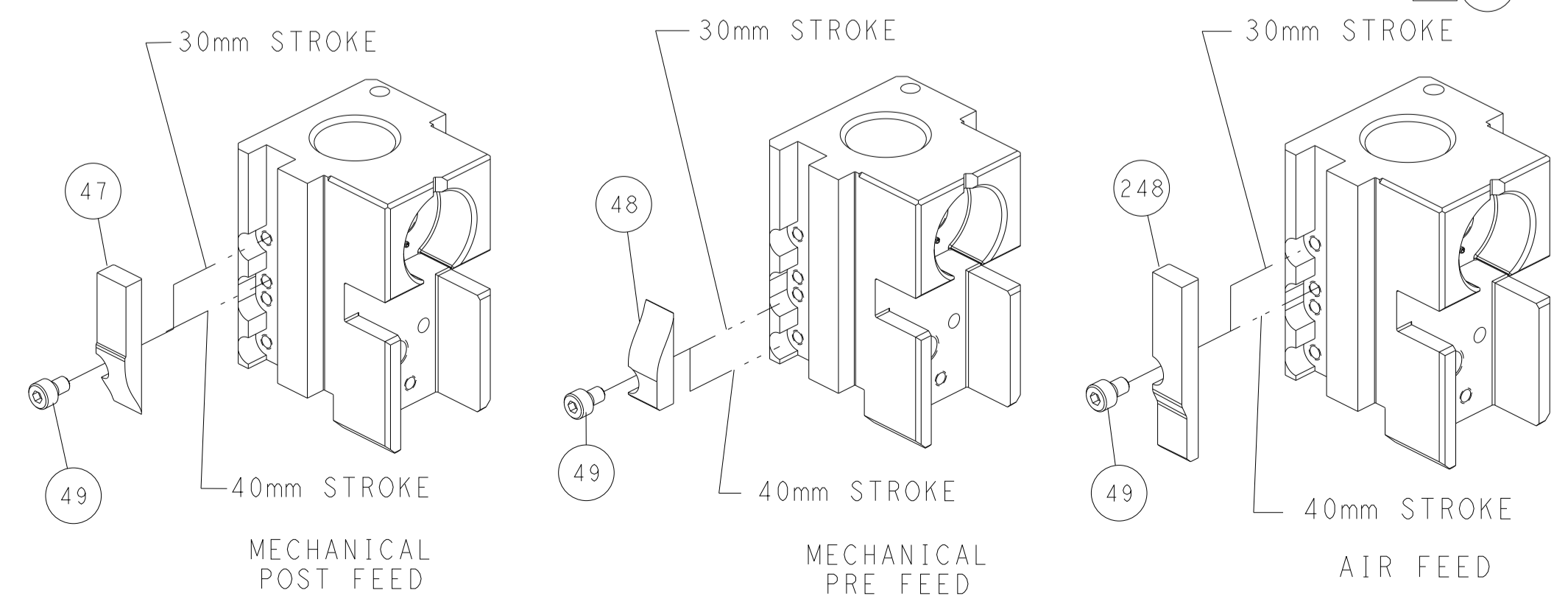

ATLANTIC VERSION
 Shown on sheets 1 of 4 & 2 of 4
 (Pacific version shown on sheets 3 of 4 & 4 of 4)

<small>THIS DRAWING IS UNPUBLISHED. RELEASED FOR PUBLICATION. 20 COPYRIGHT 20 BY TYCO ELECTRONICS CORPORATION. ALL RIGHTS RESERVED.</small>		DWN: R. HUANG 20JUN2013 CHK: L. ZHANG 20JUN2013 APVD: J. GUO 20JUN2013	NAME: Ocean Side Feed Applicator SIZE: A1 CAGE CODE: 00779 DRAWING NO: 2151985 SCALE: 1:2 SHEET: 2 of 4 REV: E
DIMENSIONS: mm TOLERANCES UNLESS OTHERWISE SPECIFIED: 0 PLC ± 1 PLC ± 2 PLC ± 3 PLC ± 4 PLC ± ANGLES FINISH	TOLERANCES UNLESS OTHERWISE SPECIFIED: ± ± ± ± ±	TE Connectivity Harrisburg, PA 17105-3608	RESTRICTED TO:

PART NUMBER	REVISION	DESCRIPTION	FEED TYPE
2-2151985-1	E	FINE CRIMP HEIGHT ADJUST	MECHANICAL
2-2151985-2	E	FINE CRIMP HEIGHT ADJUST	PNEUMATIC
7-2151985-7	A	CRIMP TOOLING KIT	-

PACIFIC VERSION TERMINATOR
INTERFACE ADAPTER



APPLICATOR DATA		
CRIMP	SIZE	TYPE
WIRE	1.40 mm [.055]	F
INSUL	1.57 mm [.062]	O
APPLICATOR INSTRUCTIONS 408-35042		

TERMINAL DATA: TE TERMINAL		TE CRIMP SPECIFICATION	
TERMINAL NAME: CONTACT, TWIN LEAF			
WIRE STRIP LENGTH		INSULATION DIAMETER RANGE	
3.18-3.96 mm [1.25-.156 IN]		Ø1.22-1.52 mm [.048-.060 IN]	
TERMINAL APPLICATION SPECIFICATION	114-9004	-	-
TERMINALS APPLIED			
TE TERMINAL	TE TERMINAL	TE TERMINAL	TE TERMINAL
583853-1	583853-8	1-583853-3	5-583853-3
531477-2	5-531477-2	5-531477-4	531477-4

WIRE SIZE	CRIMP HEIGHT mm [INCH]	CRIMP HEIGHT REFERENCE SETTING
20 AWG OR 0.50mm2	1.02 +/- 0.05 [.040 +/- .002]	5.2
0.35mm2	0.92 +/- 0.05 [.036 +/- .002]	6.4
22 AWG OR 0.30mm2	0.92 +/- 0.05 [.036 +/- .002]	6.4
0.25mm2	0.86 +/- 0.05 [.034 +/- .002]	7.0
24 AWG OR 0.20mm2	0.84 +/- 0.05 [.033 +/- .002]	7.2

- RECOMMENDED SPARE PARTS
- REFER TO SUPPLIED INSTRUCTION SHEET FOR CLEANING, LUBRICATION AND STORAGE OF APPLICATOR.
- APPLY PART NUMBER 2-23419-6 LOCTITE TO THREADS OF ITEM 242.
- CRIMP HEIGHT REFERENCE SETTING WAS THE SETTING USED WHEN THE APPLICATOR WAS QUALIFIED AT THE FACTORY. ADJUSTMENT MAY BE NECESSARY WHEN RUNNING APPLICATOR IN THE FIELD.
- 5. UNLESS SPECIFIED OTHERWISE TORQUE VALUES SHALL BE USED PER DOCUMENT, 101-35000.
- TERMINAL LUBRICANT IS RECOMMENDED.

***WARNING**
ON INSTALLATION, SET WIRE DISC TO CRIMP HEIGHT REFERENCE SETTING FOR LARGEST WIRE SIZE. CRIMP HEIGHT REFERENCE SETTINGS GREATER THAN THE VALUE SHOWN MAY CAUSE DAMAGE TO THE CRIMP TOOLING, REFER TO THE INSTRUCTION SHEET FOR PROPER SETUP AND ADJUSTMENTS.

LOC	DIST	REVISIONS					
A	66	P	LTN	DESCRIPTION	DATE	OWN	APVD
-	-	-	-	SEE SHEET 1	-	-	-

1	-	1	1	2280441-1	INSERT, SHEAR		282
	-	1	1	2119082-9	CAM, SNAIL, INSULATION ADJUSTMENT		244
	-	1	1	2079764-1	WASHER, WAVE SPRING, CREST-TO-CREST		243
3	-	1	1	2119083-1	RETAINER, INSULATION DIAL		242
	-	2	2	7-18023-7	SCR, SKT HD CAP M3 X 4.0		241
	-	-	1	2119580-1	MECHANICAL FEED ASSEMBLY		239
	-	1	-	2844940-1	AIR FEED MODULE		238
	-	1	1	356885-4	STOP, SHEAR		237
	-	REF	REF	994970-2	COUNTER, MAGNETIC		164
	-	1	-	2119641-2	FEED CAM, AIR FEED		151
	-	1	1	2168083-8	SCR, SKT HD CAP, RoHS, M4 X 16		144
	-	4	4	2168083-9	SCR, SKT HD CAP, RoHS, M4 X 20		143
	-	-	1	2119653-2	FEED CAM, POST FEED		142
	-	1	1	1-1803583-0	APPLICATOR BASIC ASSEMBLY, SF		141
	-	1	1	1803516-1	RAM ASSEMBLY, SF PACIFIC		140
	-	1	1	1-18028-2	WASHER, FLAT, REG M4		119
6	-	1	1	2119955-1	ASSY, LUBRICATOR, SIDE FEED		113
	-	1	1	2844908-1	SCREW, LOCKING		99
	-	1	1	2844907-1	POST, LOCKING		98
	-	1	1	1-690438-0	FRONT STRIP GUIDE		96
	-	2	2	2168083-1	SCR, SKT HD CAP, RoHS, M3 X 8.0		95
	-	1	1	455888-6	SPACER, CRIMPER		82
	-	1	1	5-240641-6	SPACER		81
	-	1	1	1633782-2	FENCE		78
	-	1	1	5-547505-2	SPRING, COMPRESSION		77
	-	2	2	2168083-1	SCR, SKT HD CAP, RoHS, M3 X 8.0		76
	-	1	1	854769-4	HOLDER, INS		74
	-	1	1	1803607-3	DOCUMENTATION PACKAGE		71
	-	1	1	2119740-1	TAG, IDENTIFICATION		67
	-	2	2	2168078-1	SCREW, DRIVE, RH, RoHS, 2 x .188		66
	-	2	2	2-18032-5	SCR, SET, FLT PNT, M5 X 20.0		61
	-	1	1	5-18022-5	SCR, HEX HD CAP, M4 X 6.0		59
	-	1	1	21028-2	PIN, SLOTTED SPRING .062 X .250		58
	-	1	1	1338685-1	PAWL, FEED		56
	-	2	2	2168083-9	SCR, SKT HD CAP, RoHS, M4 X 20		53
	-	1	2	18023-9	SCR, SKT HD CAP M4 X 6.0		49
	-	-	1	2119652-1	FEED CAM, PRE FEED		48
	-	1	1	1803602-1	SCR, BHSC, RoHS (M8 X 25)		41
	-	2	2	2079383-5	SCR, BHSC, RoHS (M4 X 20)		33
	-	2	2	2-2844962-3	SPACER, CYLINDRICAL, STRIP GUIDE		30
	-	1	1	2844992-3	ASSEMBLY, STRIP GUIDE		29
	-	1	1	1-455888-0	SPACER, CRIMPER		28
	-	2	2	22283-1	SPRING, COMPRESSION		27
	-	1	1	356835-1	LEVER, DRAG RELEASE		26
	-	1	1	240792-1	DRAG, TERMINAL		25
	-	1	1	1320928-2	STRIP GUIDE		24
	-	1	1	980371-4	SCR, SKT HD SHLDR 5.0 DIA X 6.0		23
	-	1	1	2168083-2	SCR, SKT HD CAP, RoHS, M4 X 8.0		21
	-	1	1	1-18028-2	WASHER, FLAT, REG M4		20
	-	1	1	2119533-1	STRIPPER, SIDE FEED		19
	-	1	1	1-690518-1	HOLD DOWN, TERMINAL		18
1	-	1	1	690463-1	FLOATING SHEAR, REAR		17
	-	2	2	1-2168083-1	SCR, SKT HD CAP, RoHS, M3 X 6		16
	-	1	1	690691-9	PLATE, REAR SHEAR		15
1	-	1	1	2119862-1	SHEAR HOLDER, REAR		14
1	-	1	1	2119806-1	INSERT, SHEAR		13
	-	2	2	3-22280-3	SPRING, COMPRESSION		12
	-	1	1	1-356885-4	STOP, SHEAR		11
	-	1	1	2119805-1	SHEAR HOLDER, FRONT		10
1	-	1	1	1803095-1	FLOATING SHEAR, FRONT		9
1	1	1	1	2-1333201-8	ANVIL, COMBINATION		8
	-	-	-	-	-		7
	-	1	1	690468-1	DEPRESSOR SHEAR, REAR		6
	-	1	1	2119780-5	DEPRESSOR, SHEAR		5
	-	1	1	238011-7	BLOCK, CRIMPER SPACER		4
1	1	1	1	1633966-6	CRIMPER, INSULATION O		3
	-	1	1	455888-3	SPACER, CRIMPER		2
1	1	1	1	2-456402-6	CRIMPER, WIRE PREMIUM		1

PACIFIC VERSION
Shown on sheets 3 of 4 & 4 of 4
(Atlantic version shown on sheets 1 of 4 & 2 of 4)

DIMENSIONS:		TOLERANCES UNLESS OTHERWISE SPECIFIED:		MATERIAL:		FINISH:		WEIGHT:		SCALE:		SHEET:		REV:	
mm	0 PLC ±	1 PLC ±	2 PLC ±	3 PLC ±	4 PLC ±	ANGLES	FINISH			A1	00779	3	4	E	



Ocean Side Feed
Applicator

LOC	DIST	REVISIONS					
A	66	P	LTN	DESCRIPTION	DATE	OWN	APVD
		-		SEE SHEET 1			

FEED TYPE MECHANICAL

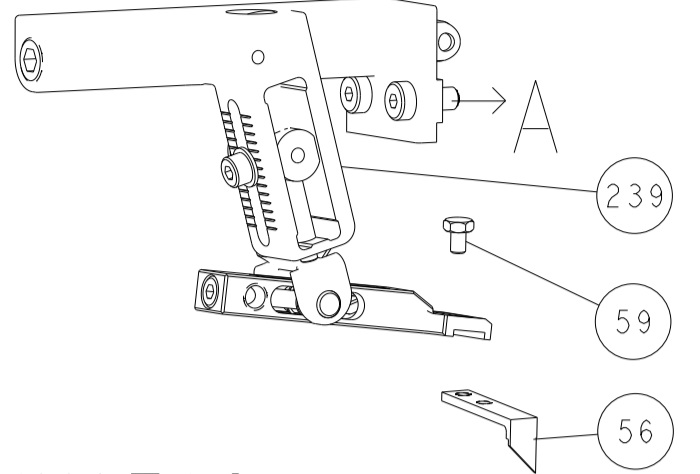

PNEUMATIC

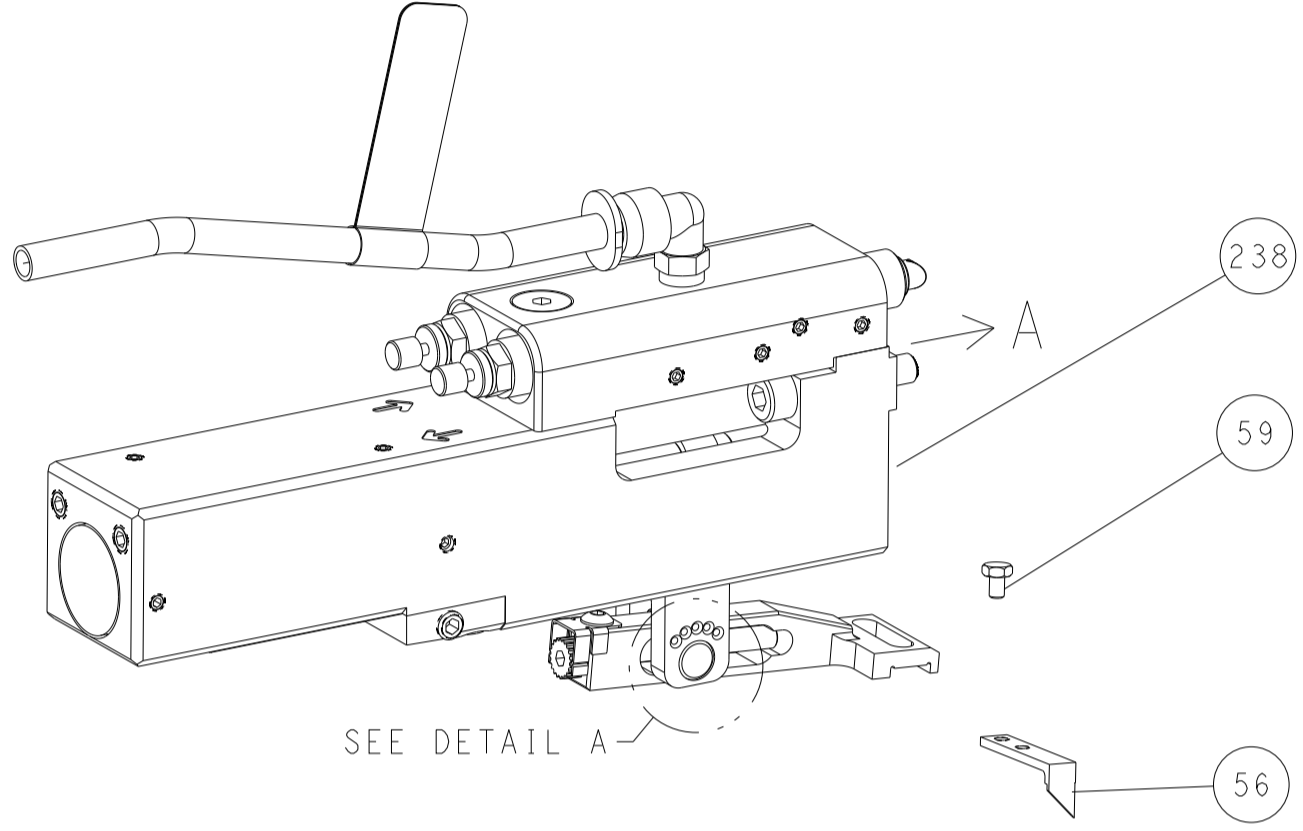

FEED SPRING SETTING POSITION (SHOWN FROM REAR SIDE)

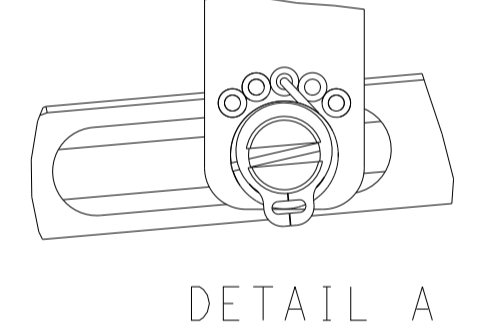

CAM POSITIONS

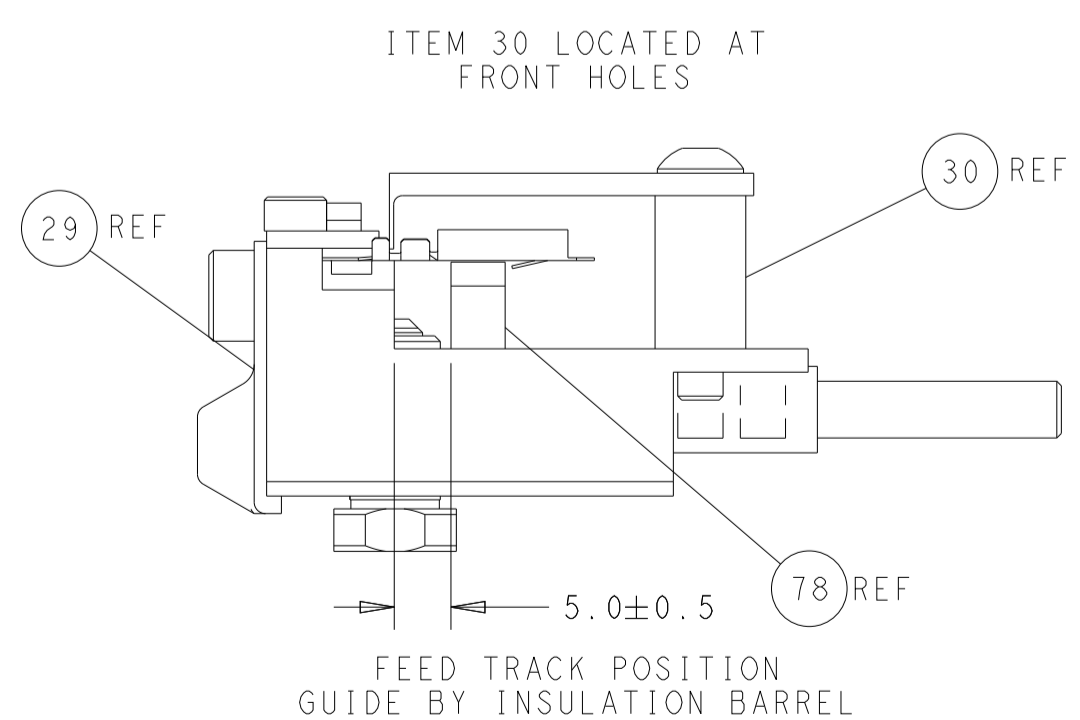
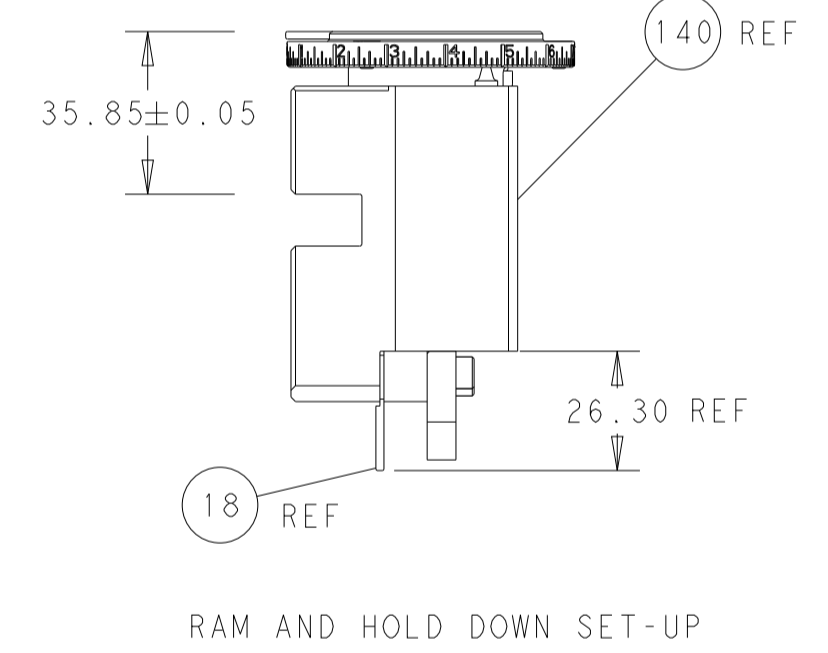
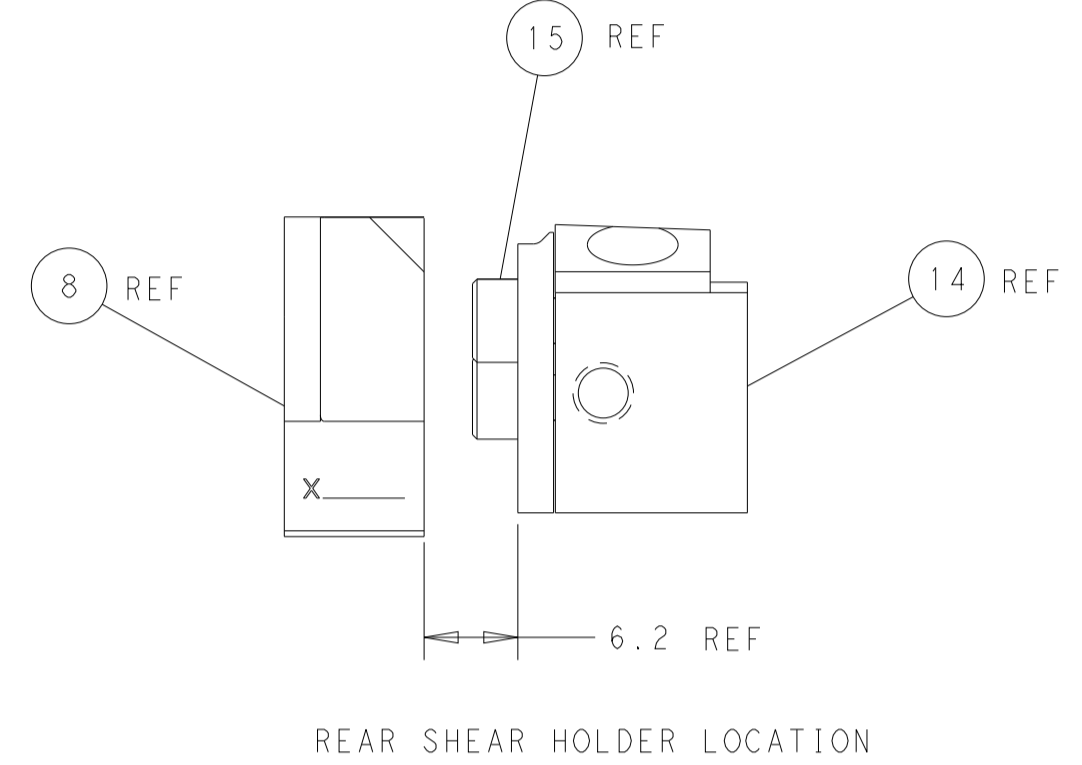
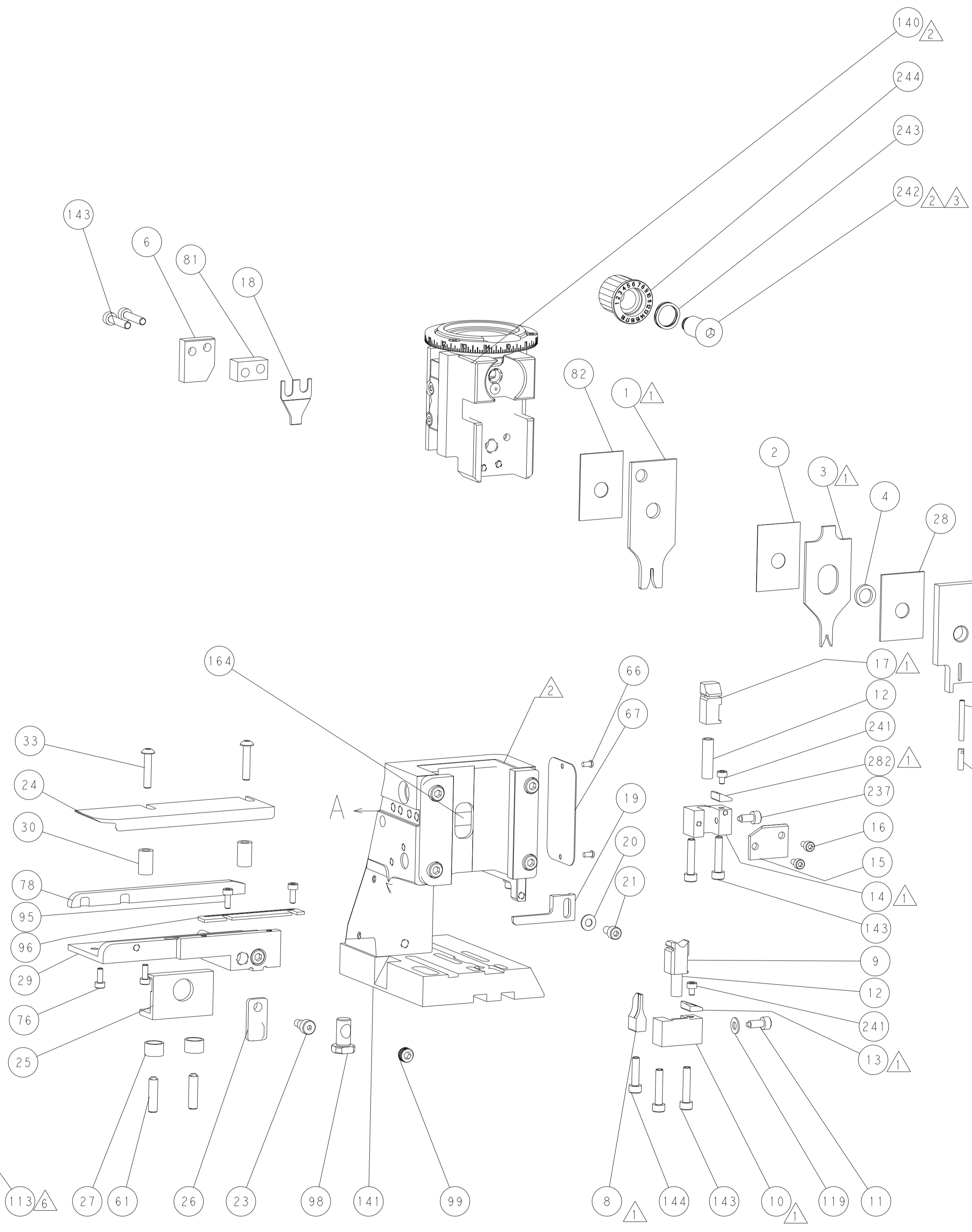
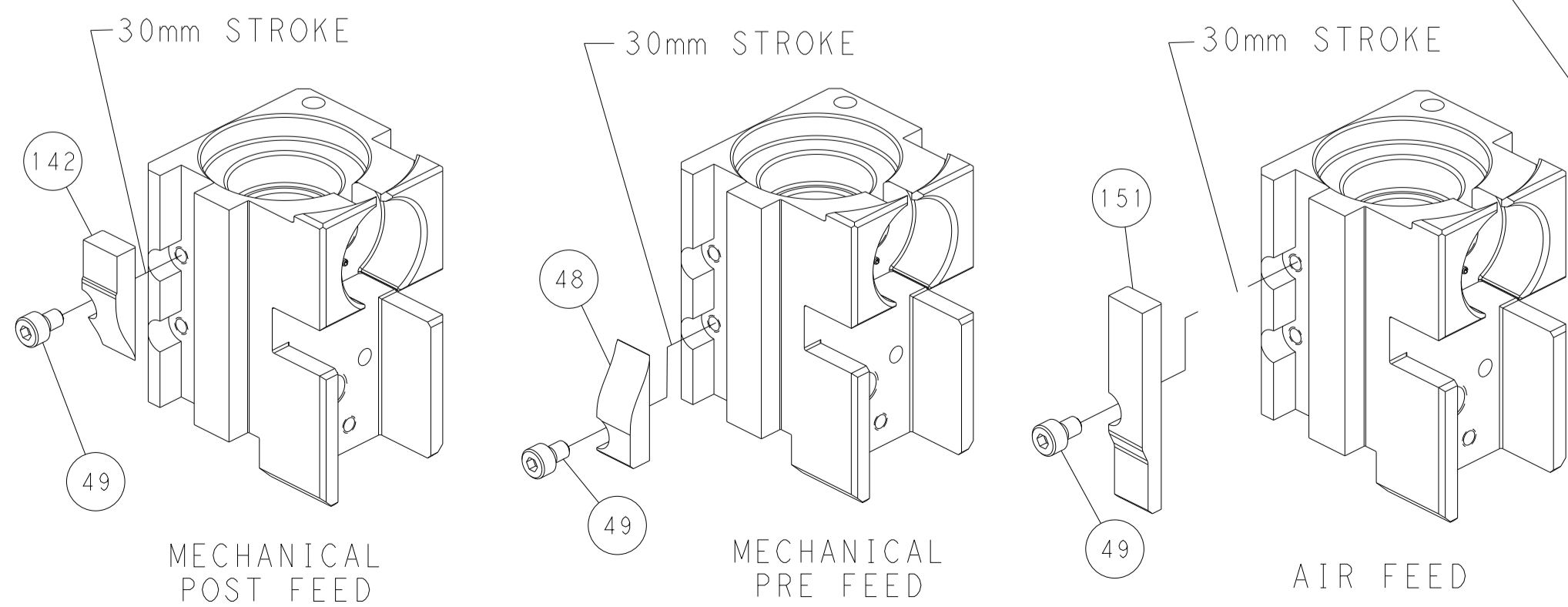

PACIFIC VERSION
 Shown on sheets 3 of 4 & 4 of 4
 (Atlantic version shown on sheets 1 of 4 & 2 of 4)

DIMENSIONS: mm 		TOLERANCES UNLESS OTHERWISE SPECIFIED: 0 PLC ± 1 PLC ± 2 PLC ± 3 PLC ± 4 PLC ± ANGLES FINISH ±		DWN R. HUANG 20JUN2013 CHK L. ZHANG 20JUN2013 APVD U. GUO 20JUN2013		NAME Ocean Side Feed Applicator	
MATERIAL:		WEIGHT:		SIZE: A1 CAGE CODE: 00779 DRAWING NO: C=2151985		RESTRICTED TO:	
Customer Accessible Production Drawing				SCALE: 1:2		SHEET 4 OF 4 REV E	