

REVISIONS				
P	LTN	DESCRIPTION	DATE	APPV
A		RELEASED	17FEB2015	LAW EW

- THIS CONNECTOR ASSEMBLY SHALL BE PACKAGED AS A KIT
- PART NUMBER CHANGES AND/OR DESIGN CHANGES AFFECTING ITEM INTERCHANGEABILITY REQUIRE PRIOR TE CONNECTIVITY APPROVAL AND AUTHORIZATION BY REVISION TO THIS DRAWING
- MATERIALS:
 HOUSING: THERMOPLASTIC, GLASS REINFORCED, UL94V-0
 FLAMMABILITY RATED, COLOR: BLACK
 PIN CONTACTS: COPPER ALLOY
 RETENTION CLIPS: BERYLLIUM COPPER OR STAINLESS STEEL
- FINISH: CONTACT-- .000200 MIN SILVER PLATE OVER .000050 MIN NICKEL
- MOUNTING HARDWARE: SHOULDER SCREW
 TE PART NUMBER 1650402-1 TO BE ORDERED SEPERATELY. SHOWN FOR REFERENCE ONLY
- REFERENCE DIMENSIONS (X.XXX) WITHOUT TOLERANCE
- PART NUMBER AND DATE CODE TO BE LABELED IN THE APPROXIMATE AREA SHOWN

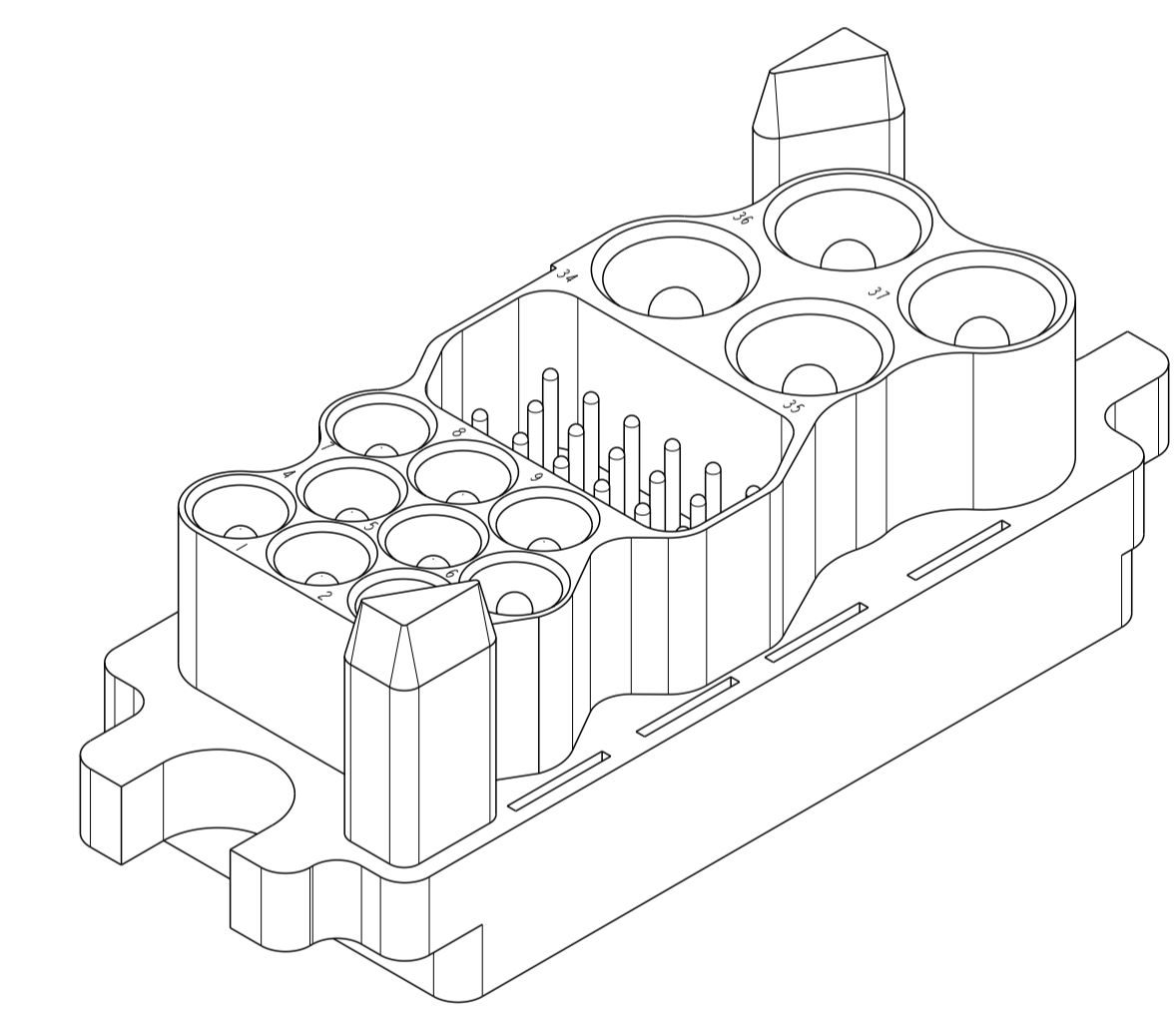
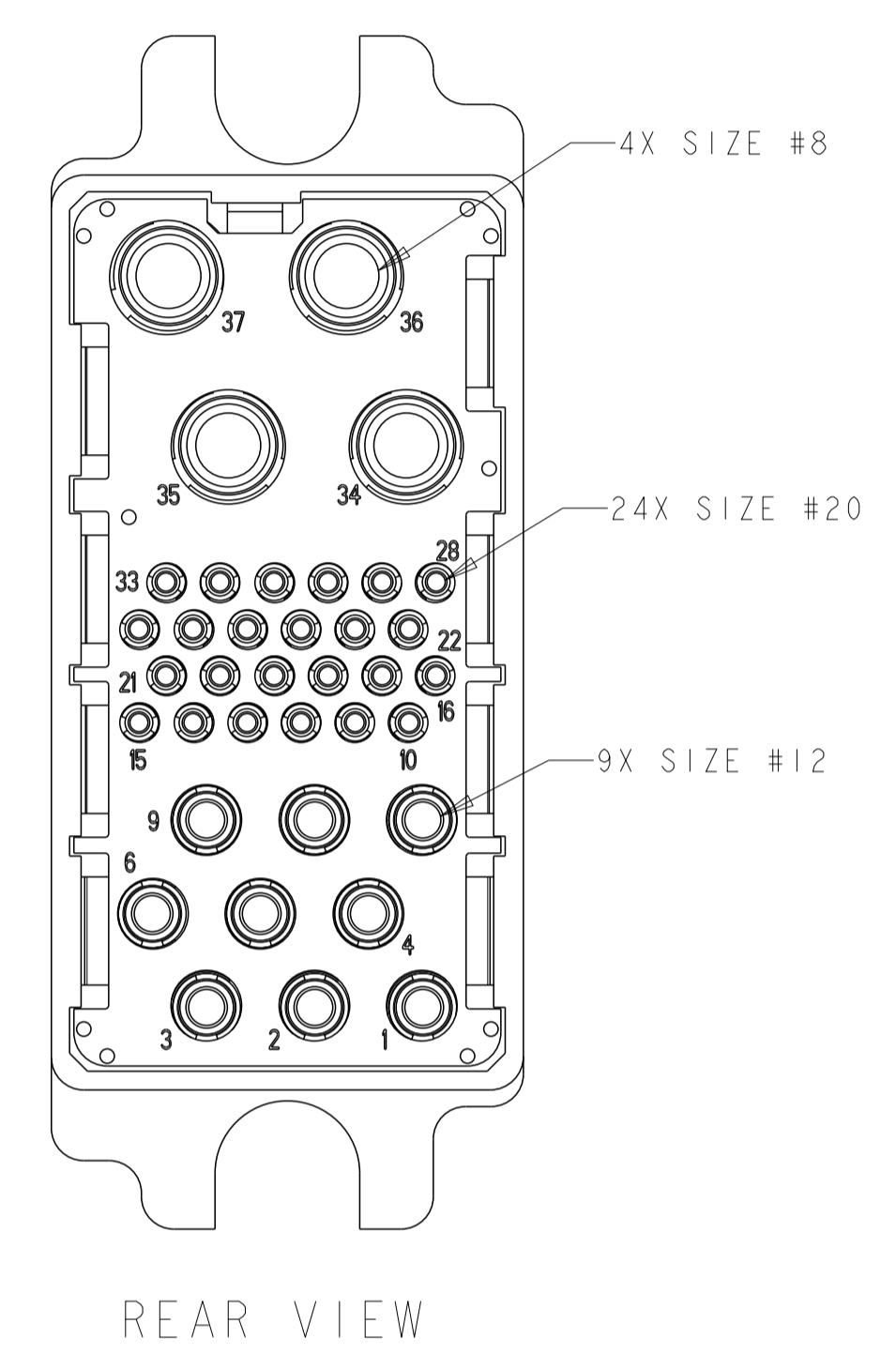
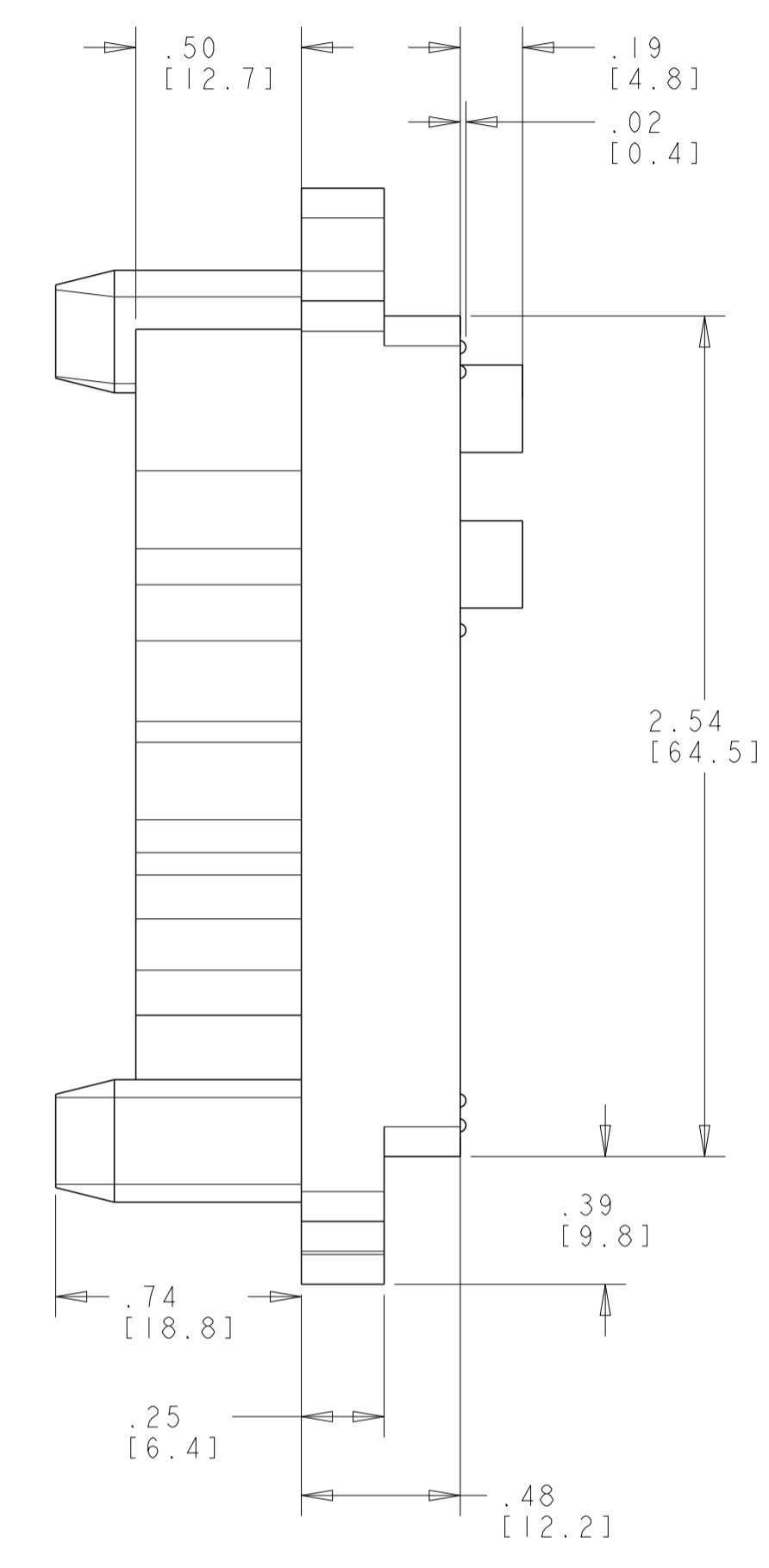
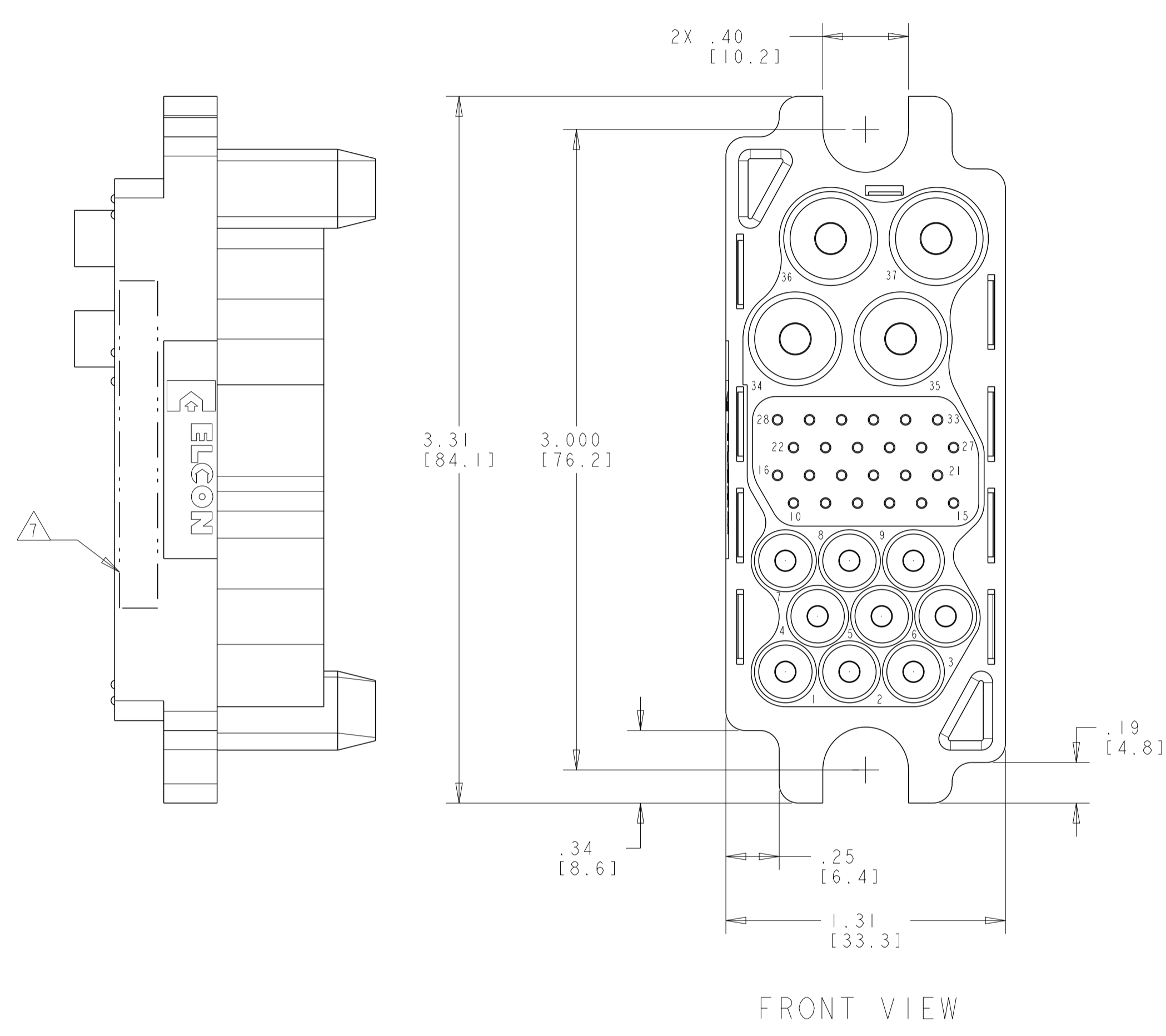

QTY	PART NUMBER	DESCRIPTION
2	1650402-1	SCREW, SHOULDER, #8-32 THD
1	1650156-2	CONTACT, PIN, #12, CRIMP, PREMATE, HP, GOLD PLATED
8	1766193-1	CONTACT, PIN, #12, CRIMP, STD, SILVER PLATED
24	1650155-1	CONTACT, PIN, #20, CRIMP, STD, GOLD PLATED
4	1766192-1	CONTACT, PIN, #8, CRIMP, STD, SILVER PLATED
1	1648163-2	CONNECTOR, PIN, PCB MOUNT

THIS DRAWING IS A CONTROLLED DOCUMENT.

DIMENSIONS: INCHES(mm)	TOLERANCES UNLESS OTHERWISE SPECIFIED: 0 PLC ± 1 PLC ±.02 (0.5) 3 PLC ±.010 (0.25) 4 PLC ± ANGLES ±° FINISH	OWN L.A. WENSEL 17FEB2015 CHK E. WICKES 17FEB2015 APPV D. ORRIS 17FEB2015	NAME STE TE Connectivity CONNECTOR ASSEMBLY, PIN, 75 AMP, MIDDLE DRAWER
MATERIAL	FINISH	WEIGHT	SIZE CAGE CODE DRAWING NO A1 - C=6643384
CUSTOMER DRAWING		SCALE 6:1	SHEET 1 OF 2 REV A

REVISIONS				
P.	LTN.	DESCRIPTION	DATE	APVD.
-	-	SEE SHEET 1	-	-

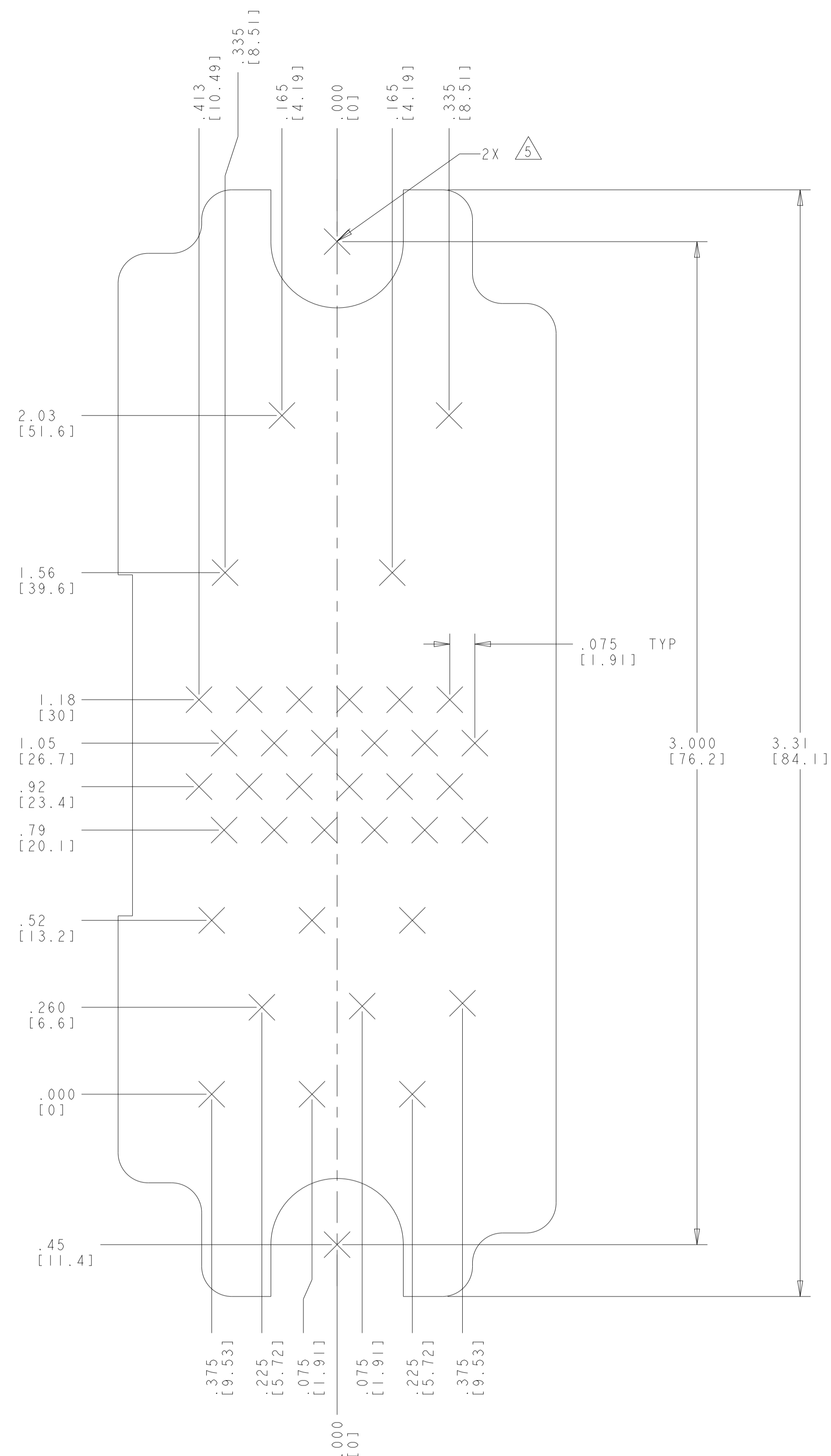

RECOMMENDED CONTACT LAYOUT
 AS VIEWED FROM CONNECTOR MOUNTING SIDE
 (FRONT VIEW)
 SCALE 4:1

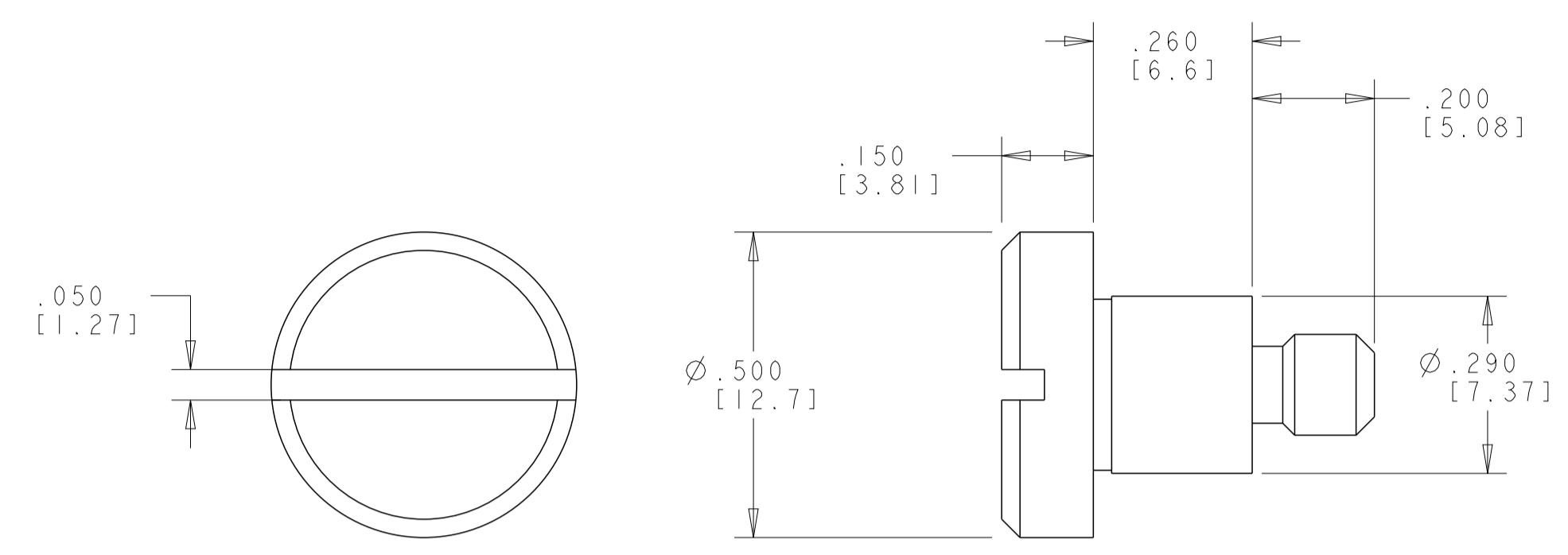

SHOULDER SCREW
 PART NUMBER 1650402-1
 SCALE 4:1

THIS DRAWING IS A CONTROLLED DOCUMENT.		DWN L.A.WENSEL 17FEB2015	TE Connectivity
DIMENSIONS: INCHES[mm]		CHK E.WICKES 17FEB2015	
TOLERANCES UNLESS OTHERWISE SPECIFIED:		APVD D.ORBIS 17FEB2015	NAME CONNECTOR ASSEMBLY, PIN, 75 AMP, MIDDLE DRAWER
0 PLC ±	1 PLC ±.02 [0.51]	PRODUCT SPEC	SIZE A1
2 PLC ±.02 [0.51]	3 PLC ±.010 [0.254]	APPLICATION SPEC	CAGE CODE DRAWING NO C=6643384
4 PLC ±	ANGLES ±5°	FINISH	RESTRICTED TO
MATERIAL	WEIGHT	CUSTOMER DRAWING	SCALE 6:1 SHEET 2 OF 2 REV A