

NOTES:

1. MATERIALS AND FINISHES:
 BODY, FERRULE AND BAYONET SLEEVE - BRASS, NICKEL PLATING
 OUTER CONTACT - BeCu, NICKEL PLATING
 CONTACT - PHOSPHOR BRONZE, GOLD PLATING
 INSULATOR - PTFE, NAUTRAL
2. ELECTRICAL:
 A. IMPEDANCE: 75 OHM
 B. FREQUENCY RANGE: DC - 12 GHz
 C. RETURN LOSS: 24 dB MIN @ DC-6 GHz
 15 dB MIN @ DC-12 GHz
 D. DIELECTRIC WITHSTANDING VOLTAGE: 1000 VRMS, MIN.
 E. INSULATION RESISTANCE: 10,000 MΩ MIN
3. MECHANICAL:
 A. DURABILITY: 500 CYCLES MIN.
 B. TEMPERATURE RANGE: -65° C TO +165° C
4. ENVIRONMENTAL:
 A. THERMAL SHOCK PER MIL-STD-202 METHOD 107
 TEST CONDITION B (EXCEPT HIGH TEMP @200°C)
 B. VIBRATION: MIL-STD-202 METHOD 204 TEST CONDITION B
 C. SHOCK: MIL-STD-202 METHOD 213 TEST CONDITION B
 D. CORROSION: MIL-STD-202 METHOD 101
 TEST CONDITION B 5% SALT SOLUTION
5. PACKAGING:
 A. QUANTITY: SINGLE PACK
 B. MARKING: BAG TO BE MARKED:
 "AMPHENOL RF, 34-1104-12G, DATE CODE
 U.S. PATENT NO. 7,553,177"
6. HIGH DENSITY INSTALLATION/REMOVAL TOOL: 227-T2000-1694A.
7. CABLE ASSEMBLY INSTRUCTIONS:
 A. TRIM CABLE AS SHOWN.
 B. SOLDER CONTACT TO CABLE CENTER CONDUCTOR
 OR CRIMP CONTACT TO CABLE CENTER
 CONDUCTOR WITH .068" HEX DIE
 C. CRIMP FERRULE WITH .324" INCH HEX DIE

8 SHOWS CABLE ENTRY DIMENSIONS.

INTERFACE PER
 349-50820
 SERIES : HD-BNC PLUG

THIRD ANGLE PROJ.

REVISIONS

REV	DESCRIPTION	DATE	ECO	APPR
A	RELEASE TO MFG.	24-Feb-17	03123	KCE

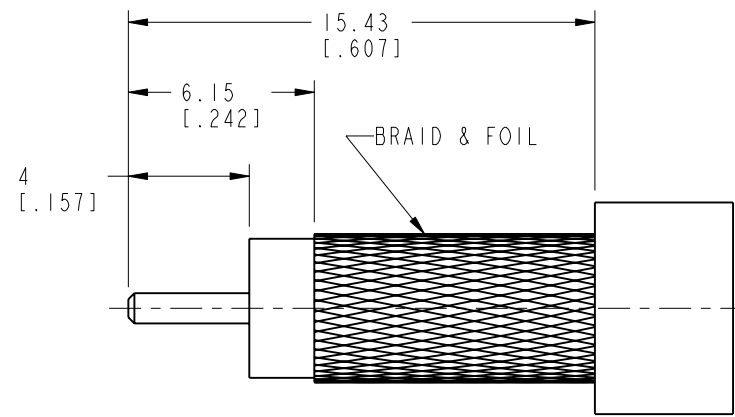

RECOMMENDED CABLE
 STRIPPING DIMENSIONS

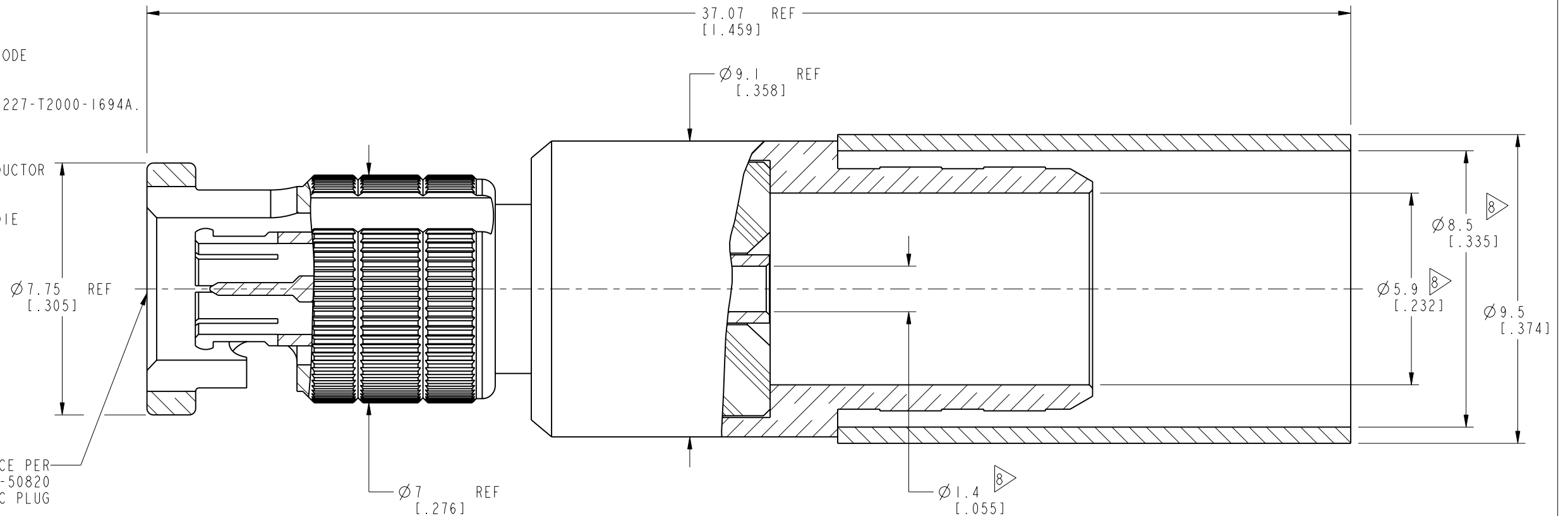
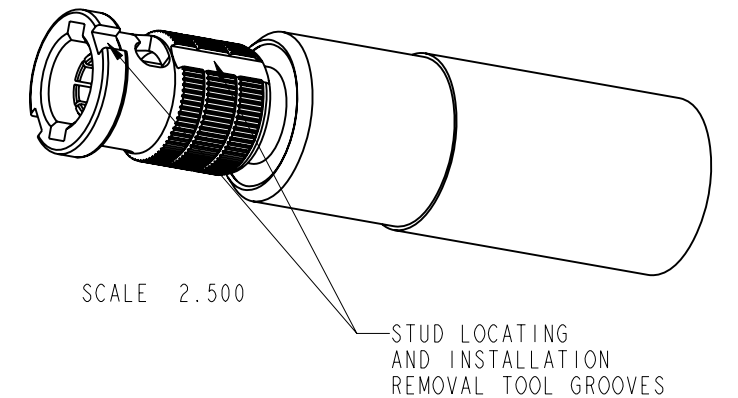

PROTECTED UNDER U.S. PATENT # 7,553,177

CUSTOMER OUTLINE DRAWING

ALL OTHER SHEETS ARE FOR INTERNAL USE ONLY

UNLESS OTHERWISE SPECIFIED, DIMENSIONS ARE IN METRIC AND TOLERANCES ARE: <0.5mm ±0.05mm 0.5 - 6mm ±0.1mm 6 - 30mm ±0.2mm 30 - 120mm ±0.3mm ANGLES ±1°	MATERIAL	DRAWN S. DUAN	DATE 24-Feb-17	TITLE HD-BNC STR PLUG FOR BELDEN 4794R 9.50 MM PITCH	Amphenol RF Danbury CT USA, Tainan, Taiwan, Shenzhen, China www.amphenolrf.com
	REFERENCE EAR # 7413	ENGINEER K. ELMES	DATE 16-Nov-16		
NOTICE - These drawings, specifications, or other data (1) are, and remain the property of Amphenol corp. (2) must be returned upon request; and (3) are confidential and not to be disclosed to any person other than those to whom they are given by Amphenol Corp. the furnishing of these drawings, specifications, or other data by Amphenol Corp., or to any other person for any purpose is not to be regarded by implication or otherwise in any manner licensing, granting rights to permitting such holder or any other person to manufacture, use or sell any product, process or design, patented or otherwise, that may in any way be related to or disclosed by said drawings, specifications, or other data.	CONFIGURATION LEVEL:	APPROVED S. HSIEH	DATE 28-Feb-17	SCALE: 6.8:1.0	SHEET 2 OF 2
	FINISH	CAD FILE	DWG SIZE B	REV A	ITEM NO. 34-1104-12G